

■ General Description

The AME8816 family of positive, linear regulators feature low quiescent current (45µA typ.) with low dropout voltage, making them ideal for battery applications.

Output voltages are set at the factory and trimmed to 1.5% accuracy.

These rugged devices have both Thermal Shutdown, and Current Fold-back to prevent device failure under the "Worst" operating conditions.

In applications requiring a low noise, regulated supply, place a 1000pF capacitor between Bypass and Ground.

The AME8816 is stable with an output capacitance of 4.7µF or greater.

■ Features

- Very Low Dropout Voltage
- Guaranteed 1.5A Output
- Accurate to within 1.5%
- 45µA Quiescent Current Typically
- Over-Temperature Shutdown
- Current Limiting
- Short Circuit Current Fold-back
- Noise Reduction Bypass Capacitor (Fixed Versions)
- Power-Saving Shutdown Mode
- Low Temperature Coefficient
- Adjustable Version
- All AME' s Lead Free Products Meet RoHS Standards

■ Applications

- Instrumentation
- Portable Electronics
- Wireless Devices
- PC Peripherals
- Battery Powered Widgets

■ Functional Block Diagram (Fixed Versions)

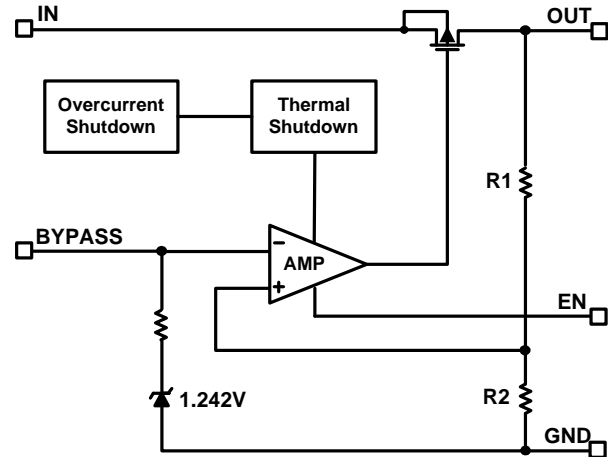

(Adjustable Version)

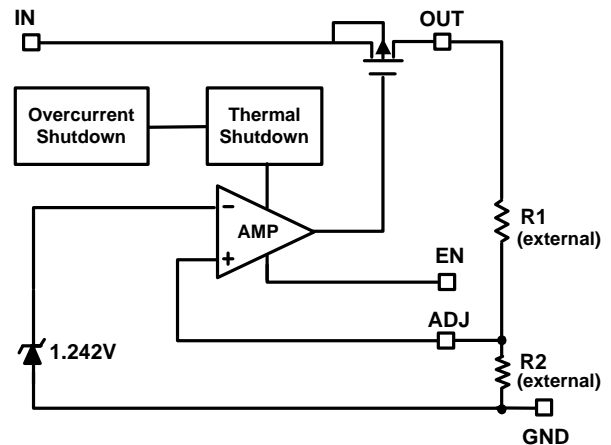

■ Typical Application

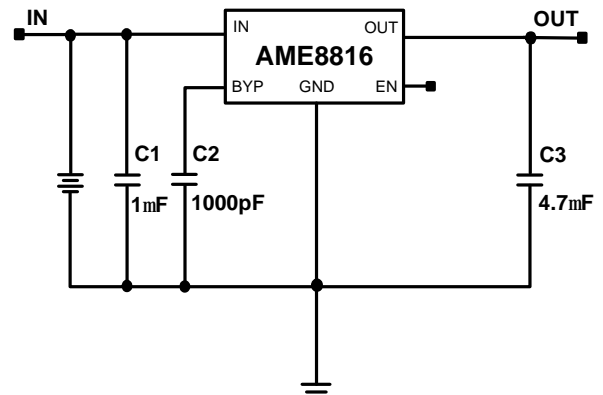

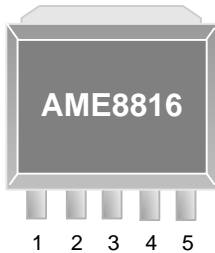
■ Pin Configuration
**TO-263-5
Top View**

AME 8816AEDVxxx

1. EN
2. IN
3. GND(TAB)
4. OUT
5. BYP

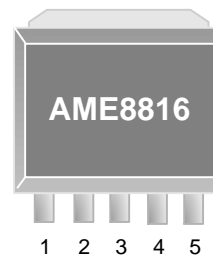
*** Die Attach:
Conductive Epoxy**

**TO-263-5
Top View**

AME8816BEDVADJ

1. EN
2. IN
3. GND(TAB)
4. OUT
5. ADJ

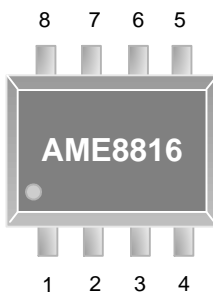
*** Die Attach:
Conductive Epoxy**

**SOP-8
Top View**

AME 8816AEHAxxx

1. BYP
2. GND
3. GND
4. EN
5. IN
6. GND
7. GND
8. OUT

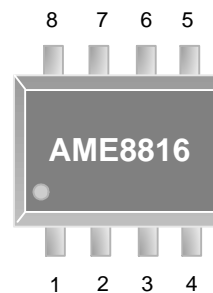
*** Die Attach:
Conductive Epoxy**

**SOP-8
Top View**

AME 8816BEHAADJ

1. ADJ
2. GND
3. GND
4. EN
5. IN
6. GND
7. GND
8. OUT

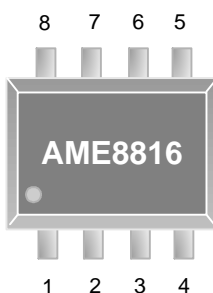
*** Die Attach:
Conductive Epoxy**

**SOP-8
Top View**

AME 8816CEHAADJ

1. EN
2. IN
3. OUT
4. ADJ
5. GND
6. GND
7. GND
8. GND

*** Die Attach:
Conductive Epoxy**

■ Pin Description

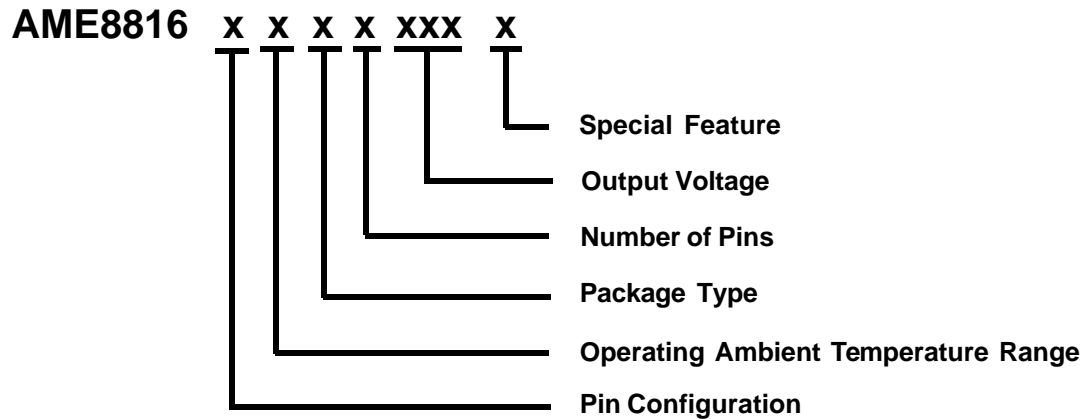
Pin Name	Pin Description
IN	Input voltage pin. It should be decoupled with 1 μ F or greater capacitor.
GND	Ground connection pin.
EN	Enable pin. When pulled low, the PMOS pass transistor turns off, current consuming less than 1 μ A.
BYP	Bypass capacitor connection. To improve AC ripple rejection, connect a 1000pF capacitor to GND. This will also provide a soft-start function.
OUT	LDO voltage regulator output pin. It should be decoupled with a 4.7 μ F or greater value low ESR ceramic capacitor.
ADJ	Feedback output voltage for adjustable device.

■ Ordering Information

Pin Configuration	Operating Ambient Temperature Range	Package Type	Number of Pins	Output Voltage	Special Feature
A (TO-263-5) 1. EN 2. IN 3. GND 4. OUT 5. BYP	E: -40°C to +85°C	D: TO-263 H: SOP	A: 8 V: 5	ADJ: Adjustable 120: V=1.2V 150: V=1.5V 180: V=1.8V 250: V=2.5V 330: V=3.3V 475: V=4.75V 500: V=5.0V	Z: Lead Free
B (TO-263-5) 1. EN 2. IN 3. GND 4. OUT 5. ADJ					
A (SOP-8) 1. BYP 2. GND 3. GND 4. EN 5. IN 6. GND 7. GND 8. OUT					
B (SOP-8) 1. ADJ 2. GND 3. GND 4. EN 5. IN 6. GND 7. GND 8. OUT					
C (SOP-8) 1. EN 2. IN 3. OUT 4. ADJ 5. GND 6. GND 7. GND 8. GND					

■ Ordering Information

Part Number	Marking*	Output Voltage	Package	Operating Ambient Temperature Range
AME8816AEDV150	AME8816 AEDV150 yyww	1.50	TO-263-5	- 40°C to +85°C
AME8816AEDV150Z	AME8816 AEDV150 yyww	1.50	TO-263-5	- 40°C to +85°C
AME8816AEDV180	AME8816 AEDV180 yyww	1.80	TO-263-5	- 40°C to +85°C
AME8816AEDV180Z	AME8816 AEDV180 yyww	1.80	TO-263-5	- 40°C to +85°C
AME8816AEDV250	AME8816 AEDV250 yyww	2.50	TO-263-5	- 40°C to +85°C
AME8816AEDV250Z	AME8816 AEDV250 yyww	2.50	TO-263-5	- 40°C to +85°C
AME8816AEDV330	AME8816 AEDV330 yyww	3.30	TO-263-5	- 40°C to +85°C
AME8816AEDV330Z	AME8816 AEDV330 yyww	3.30	TO-263-5	- 40°C to +85°C
AME8816AEDV475	AME8816 AEDV475 yyww	4.75	TO-263-5	- 40°C to +85°C
AME8816AEDV475Z	AME8816 AEDV475 yyww	4.75	TO-263-5	- 40°C to +85°C
AME8816AEDV500	AME8816 AEDV500 yyww	5.00	TO-263-5	- 40°C to +85°C
AME8816AEDV500Z	AME8816 AEDV500 yyww	5.00	TO-263-5	- 40°C to +85°C

Note: yyww represents the date code

* A line on top of the first character represents lead free plating such as $\overline{\text{AME8816}}$

Please consult AME sales office or authorized Rep./Distributor for the availability of output voltage and package type.

■ Ordering Information (contd.)

Part Number	Marking*	Output Voltage	Package	Operating Ambient Temperature Range
AME8816BEDVADJ	AME8816 BEDVADJ yyww	ADJ	TO-263-5	- 40°C to +85°C
AME8816BEDVADJZ	AME8816 BEDVADJ yyww	ADJ	TO-263-5	- 40°C to +85°C
AME8816AEHA150	AME8816 AEHA150 yyww	1.50	SOP-8	- 40°C to +85°C
AME8816AEHA150Z	AME8816 AEHA150 yyww	1.50	SOP-8	- 40°C to +85°C
AME8816AEHA180	AME8816 AEHA180 yyww	1.80	SOP-8	- 40°C to +85°C
AME8816AEHA180Z	AME8816 AEHA180 yyww	1.80	SOP-8	- 40°C to +85°C
AME8816AEHA250	AME8816 AEHA250 yyww	2.50	SOP-8	- 40°C to +85°C
AME8816AEHA250Z	AME8816 AEHA250 yyww	2.50	SOP-8	- 40°C to +85°C
AME8816AEHA330	AME8816 AEHA330 yyww	3.30	SOP-8	- 40°C to +85°C
AME8816AEHA330Z	AME8816 AEHA330 yyww	3.30	SOP-8	- 40°C to +85°C
AME8816AEHA475	AME8816 AEHA475 yyww	4.75	SOP-8	- 40°C to +85°C
AME8816AEHA475Z	AME8816 AEHA475 yyww	4.75	SOP-8	- 40°C to +85°C

■ Ordering Information (contd.)

Part Number	Marking*	Output Voltage	Package	Operating Ambient Temperature Range
AME8816AEHA500	AME8816 AEHA500 yyww	5.00	SOP-8	- 40°C to +85°C
AME8816AEHA500Z	AME8816 AEHA500 yyww	5.00	SOP-8	- 40°C to +85°C
AME8816BEHAADJ	AME8816 BEHAADJ yyww	ADJ	SOP-8	- 40°C to +85°C
AME8816BEHAADJZ	AME8816 BEHAADJ yyww	ADJ	SOP-8	- 40°C to +85°C
AME8816CEHAADJ	AME8816 CEHAADJ yyww	ADJ	SOP-8	- 40°C to +85°C
AME8816CEHAADJZ	AME8816 CEHAADJ yyww	ADJ	SOP-8	- 40°C to +85°C
AME8816AEHA120Z	AME8816 AEHA120 yyww	1.20	SOP-8	- 40°C to +85°C
AME8816AEDV120Z	AME8816 AEDV120 yyww	1.20	TO-263-5	- 40°C to +85°C

■ Absolute Maximum Ratings

Parameter	Maximum	Unit
Input Voltage	-0.3 to +8	V
EN, BYP Voltage	-0.3 to +8	V
Output Voltage	-0.3 to $V_{IN} + 0.3$	V
Output Current	$P_D / (V_{IN} - V_{OUT})$	mA
ESD Classification	B*	

Caution: Stress above the listed absolute maximum rating may cause permanent damage to the device.

* HBM B:2000V~3999V

■ Recommended Operating Conditions

Parameter	Symbol	Rating	Unit
Ambient Temperature Range	T_A	- 40 to +85	°C
Junction Temperature Range	T_J	- 40 to +125	°C
Storage Temperature Range	T_{STG}	- 65 to +150	°C

■ Thermal Information

Parameter	Package	Die Attach	Symbol	Maximum	Unit
Thermal Resistance (Junction to Case)	TO-263-5*	Conductive Epoxy	θ_{JC}	5	°C / W
	SOP-8**			60	
Thermal Resistance (Junction to Ambient)	TO-263-5		θ_{JA}	80	
	SOP-8			150	
Internal Power Dissipation	TO-263-5		P_D	1700	mW
	SOP-8			810	
Maximum Junction Temperature				150	°C
Solder Iron(10 Sec)***				350	°C

* Measure θ_{JC} on backside center of tab.

** Measure θ_{JC} on center of molding compound if IC has no tab.

*** MIL-STD-202G210F

■ Electrical Specifications
 $V_{IN} = V_{O(NOM)} + 2V$, $V_{EN} = V_{IN}$, $T_A = 25^\circ C$ unless otherwise noted

Parameter	Symbol	Test Condition	Min	Typ	Max	Units	
Input Voltage	V_{IN}		Note 1		7	V	
Output Voltage Accuracy	V_O	$V_{EN} = V_{EHmin}$, $I_O=1mA$	-1.5		1.5	%	
Dropout Voltage	$V_{DROPOUT}$	$I_O=1.5A$ $V_O=V_{O(NOM)} - 2.0\%$	$1.5V < V_{O(NOM)} \leq 2.0V$	See chart	1300	mV	
			$2.0V < V_{O(NOM)} \leq 2.8V$		800		
			$2.8V < V_{O(NOM)}$		600		
Output Current	I_O	$V_O > 1.2V$	1500			mA	
Current Limit	I_{LIM}	$V_O > 1.2V$	1500	2000		mA	
Short Circuit Current	I_{SC}	$V_O < 0.4V$		750		mA	
Quiescent Current (For Fixed Output Voltage Options)	I_Q	$I_O=0mA$		45	70	μA	
Minimum Load Current (For ADJ Option)	I_{MIN}		1			mA	
Ground Pin Current	I_{GND}	$I_O=1mA$ to 1.5A		45		μA	
Line Regulation	REG_{LINE}	$I_O=1mA$ $V_{IN}=V_O+1$ to V_O+2	$V_O < 2.0V$	-0.15		0.15	%
			$4.0 > V_O \geq 2.0V$	-0.1	0.02	0.1	%
			$4.0V \leq V_O$	-0.4		0.4	%
Load Regulation	REG_{LOAD}	$I_O=1mA$ to 1.5A	-1	0.2	1	%	
Over Temperature Shutdown	OTS			150		$^\circ C$	
Over Temperature Hysteresis	OTH			30		$^\circ C$	
V_O Temperature Coefficient	TC			30		ppm/ $^\circ C$	
ADJ Input Bias Current	I_{ADJ}	$V_{IN} = 5V$, $V_{ADJ} = 1.242V$		1		μA	
ADJ Reference Voltage	V_{REF}		1.223	1.242	1.261	V	
Power Supply Rejection	PSRR	$I_O=100mA$ $C_O=4.7\mu F$ ceramic	$f=100Hz$				dB
			$f=1kHz$		50		
			$f=10kHz$		20		
Power Supply Rejection	PSRR	$I_O=100mA$ $C_O=4.7\mu F$ ceramic $C_{BYP}=0.01\mu F$	$f=100Hz$				dB
			$f=1kHz$		75		
			$f=10kHz$		55		
Output Voltage Noise	eN	$f=10Hz$ to 100kHz $I_O=10mA$, $C_{BYP}=0\mu F$			30	μV_{rms}	
Output Voltage Noise	eN	$f=10Hz$ to 100kHz $I_O=10mA$, $C_{BYP}=0.01\mu F$			30	μV_{rms}	
EN Input Threshold	V_{EH}		2.0		V_{IN}	V	
	V_{EL}		0		0.4	V	
EN Input Bias Current	I_{EH}	$V_{IN} = 7V$			0.1	μA	
	I_{EL}	$V_{EN}=0V$, $V_{IN}=7V$			0.5	μA	
Shutdown Supply Current	I_{SD}	$V_{IN} = 5V$, $V_O=0V$, $V_{EN}=0V$		0.5	2	μA	

 Note1: $V_{IN(min)} = V_{OUT} + V_{DROPOUT}$

 Note2: $V_{O(nom)}$: nominal output voltage of fixed version

■ Detailed Description

The AME8816 family of CMOS regulators contain a PMOS pass transistor, voltage reference, error amplifier, over-current protection, and thermal shutdown.

The P-channel pass transistor receives data from the error amplifier, over-current shutdown, and thermal protection circuits. During normal operation, the error amplifier compares the output voltage to a precision reference. Over-current and Thermal shutdown circuits become active when the junction temperature exceeds 140°C, or the current exceeds 2.2A. During thermal shutdown, the output voltage remains low. Normal operation is restored when the junction temperature drops below 120°C.

The AME8816 behaves like a current source when the load reaches 2.2A. However, if the load impedance drops below 0.3 ohms, the current drops back to 600mA to prevent excessive power dissipation. Normal operation is restored when the load resistance exceeds 0.75 ohms.

■ External Capacitors

The AME8816 is stable with an output capacitor to ground of 4.7µF or greater. Ceramic capacitors have the lowest ESR, and will offer the best AC performance. Conversely, Aluminum Electrolytic capacitors exhibit the highest ESR, resulting in the poorest AC response. Unfortunately, large value ceramic capacitors are comparatively expensive. One option is to parallel a 0.1µF ceramic capacitor with a 10µF Aluminum Electrolytic. The benefit is low ESR, high capacitance, and low overall cost.

A second capacitor is recommended between the input and ground to stabilize V_{in} . The input capacitor should be at least 0.1µF to have a beneficial effect.

A third capacitor can be connected between the BY-PASS pin and GND. This capacitor can be a low cost Polyester Film variety between the value of 0.001 ~ 0.01µF. A larger capacitor improves the AC ripple rejection, but also makes the output come up slowly. This "Soft" turn-on is desirable in some applications to limit turn-on surges.

All capacitors should be placed in close proximity to the pins. A "Quiet" ground termination is desirable. This can be achieved with a "Star" connection.

■ Enable

When pulled low, the PMOS pass transistor shuts off, and all internal circuits are powered down. In this state, the quiescent current is less than 1µA. This pin behaves much like an electronic switch.

100Kohm resistor is necessary between V_{EN} source and EN pin when V_{EN} is higher than V_{IN} .

(Note: There is no internal pull-up for EN PIN.)

■ Adjustable Version

The adjustable version uses external feedback resistors to generate an output voltage anywhere from 1.5V to 5.0V. V_{adj} is trimmed to 1.242V and V_{OUT} is given by the equation:

$$V_{OUT} = V_{adj} (1 + R1 / R2)$$

Feedback resistors R1 and R2 should be high enough to keep quiescent current low, but increasing $R1 + R2$ will reduce stability. In general, R1 and R2 in the 10' s of kΩ will produce adequate stability, given reasonable layout precautions. To improve stability characteristics, keep parasitics on the ADJ pin to a minimum, and lower R1 and R2 values.

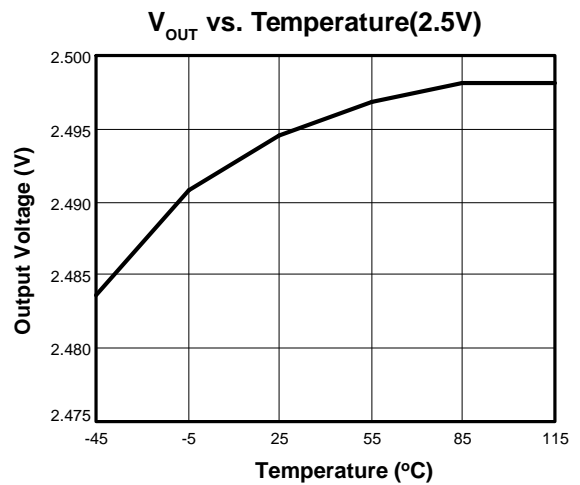
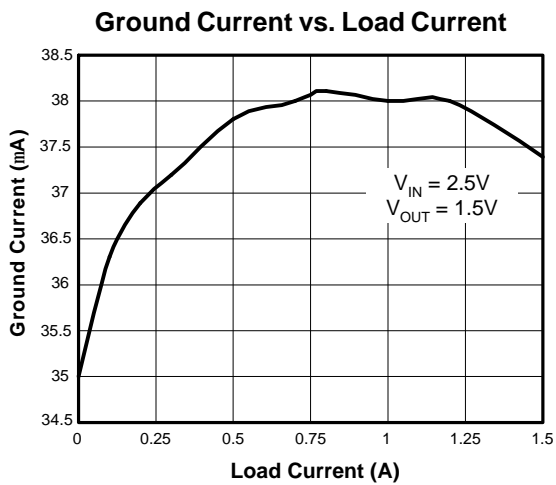
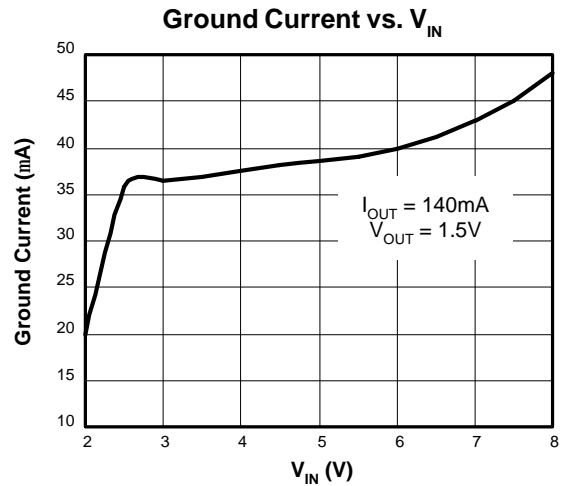
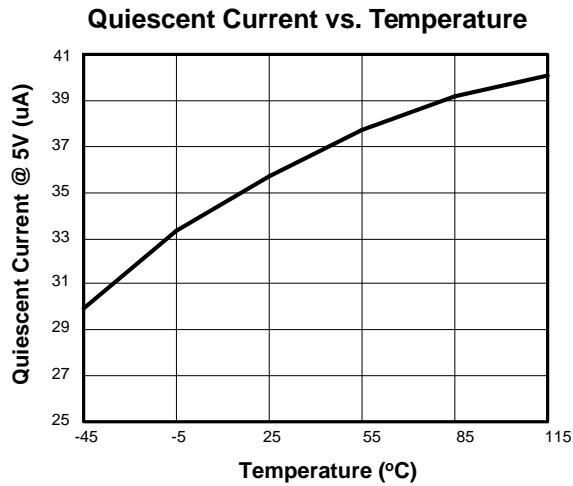
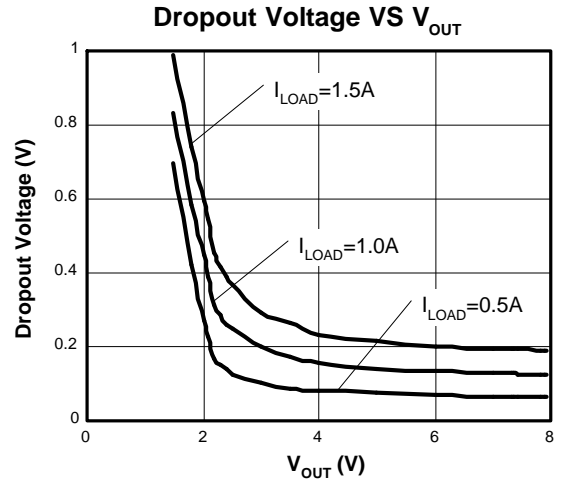
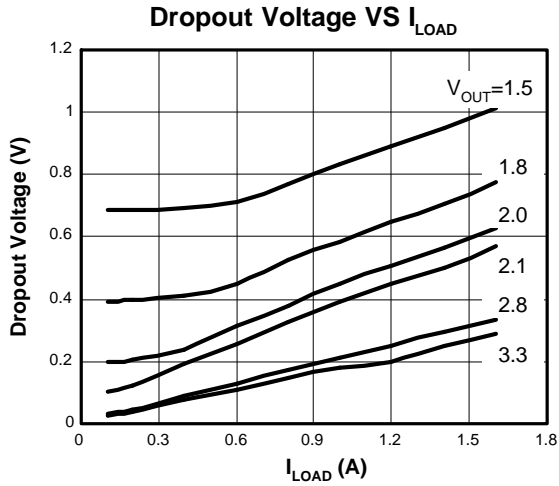

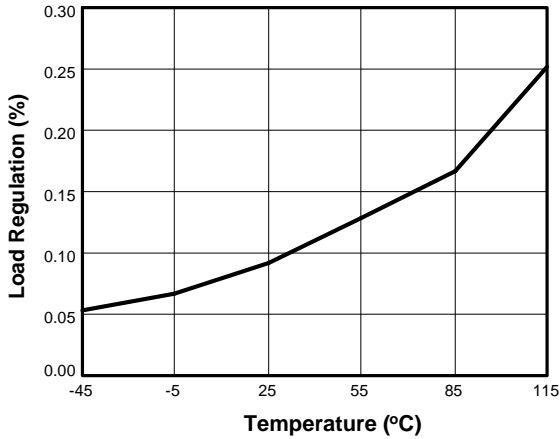
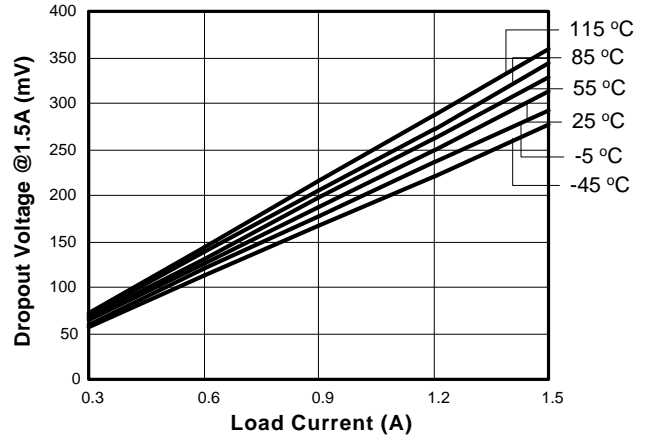
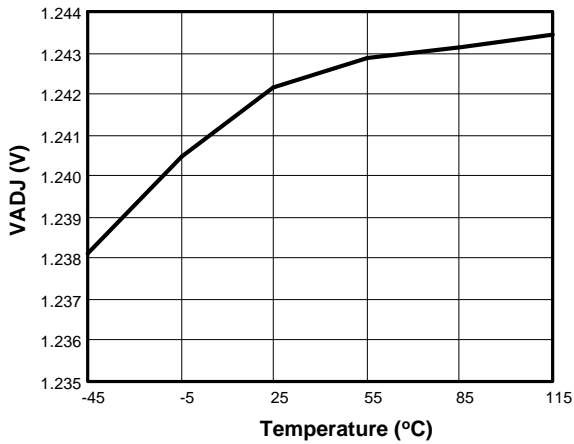
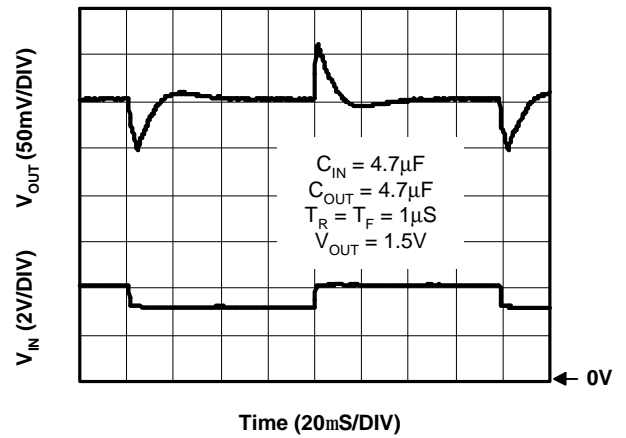
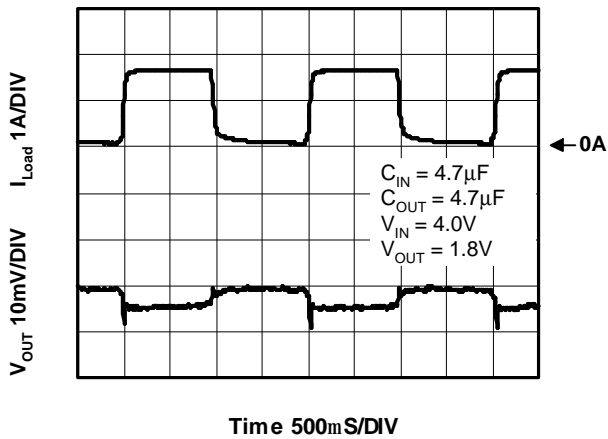
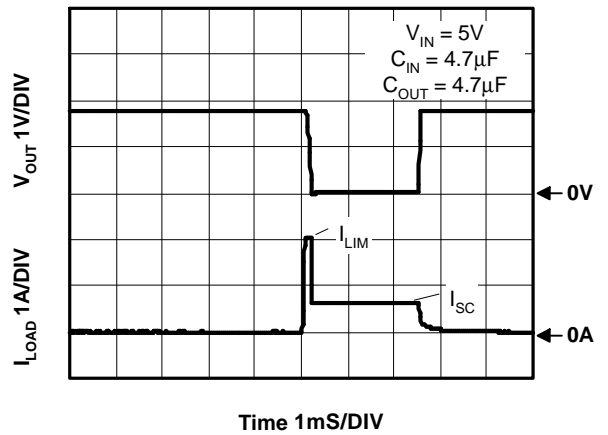
Load Regulation vs. Temperature

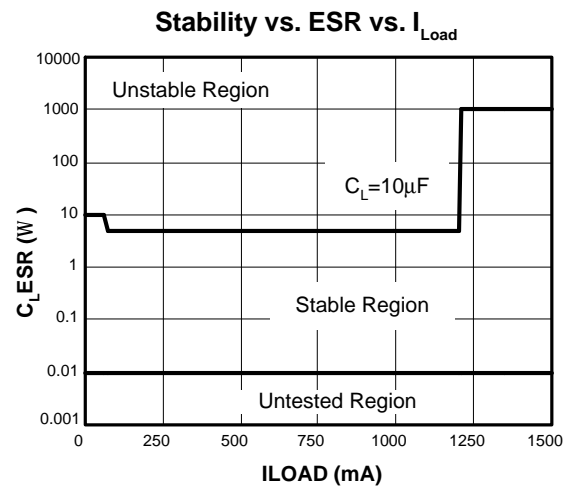
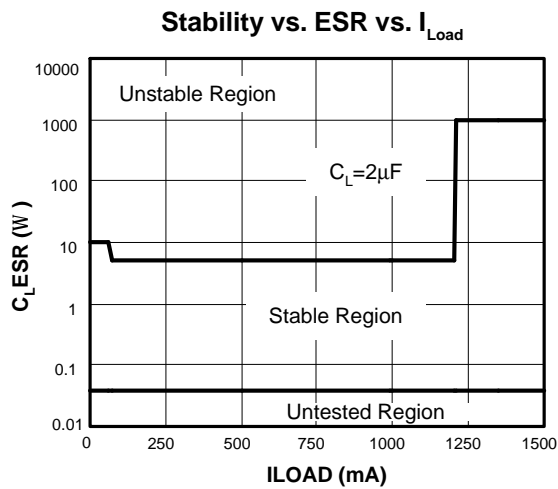
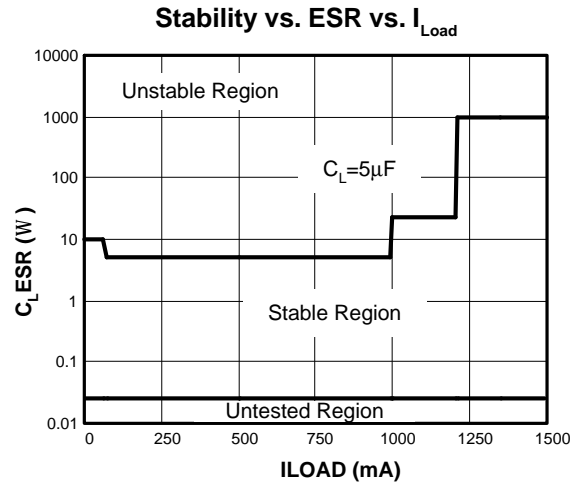
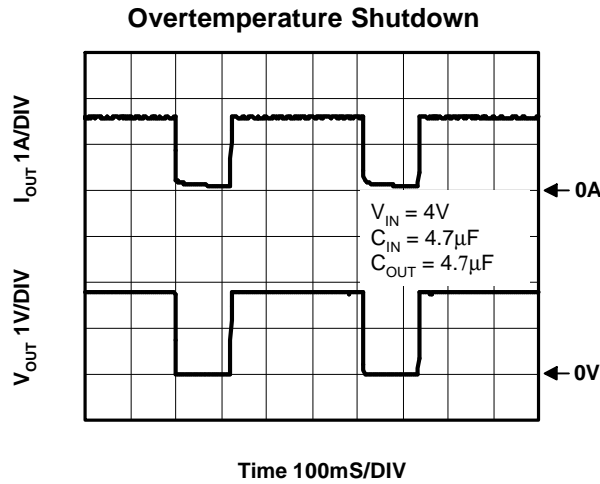
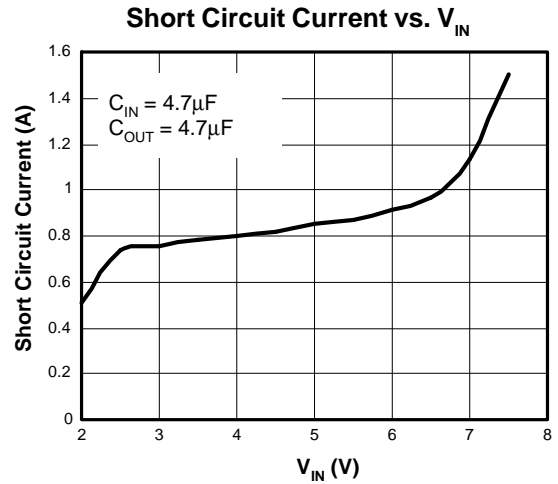
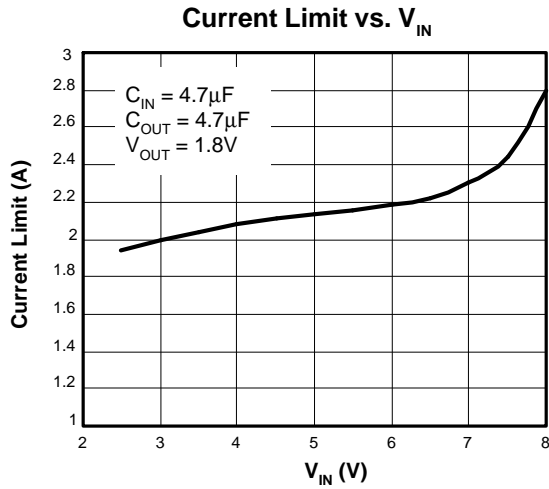
Dropout Voltage vs. Load Current(2.5V)

AME8816BEHA VADJ vs. Temperature

Line Transient Response

Load Step 40mA to 1.5A

Current Limit Response



External Resistor Divider Table

R1 (K Ohm)	1	2	5	10	20	50	100	200	500	1000
Vout	$R2(\text{kohm})=(1.242 \cdot R1(\text{kohm})) / (Vout - 1.242)$									
1.30	21.41	42.83	107.07	214.14	428.28	1070.69				
1.35	11.50	23.00	57.50	115.00	230.00	575.00				
1.40	7.86	15.72	39.30	78.61	157.22	393.04				
1.45	5.97	11.94	29.86	59.71	119.42	298.56	597.55			
1.50	4.81	9.63	24.07	48.14	96.28	240.70	481.68	962.79		
1.55	4.03	8.06	20.16	40.32	80.65	201.62	403.44	806.49		
1.60	3.47	6.94	17.35	34.69	69.39	173.46	347.07	693.85		
1.65	3.04	6.09	15.22	30.44	60.88	152.21	304.52	608.82		
1.70	2.71	5.42	13.56	27.12	54.24	135.59	271.27	542.36		
1.75	2.44	4.89	12.22	24.45	48.90	122.24	244.56	488.98		
1.80	2.23	4.45	11.13	22.26	44.52	111.29	222.64	445.16		
1.85	2.04	4.09	10.21	20.43	40.86	102.14	204.33	408.55		
1.90	1.89	3.78	9.44	18.88	37.75	94.38	188.80	377.51		
1.95	1.75	3.51	8.77	17.54	35.08	87.71	175.46	350.85	877.12	
2.00	1.64	3.28	8.19	16.39	32.77	81.93	163.88	327.70	819.26	
2.05	1.54	3.07	7.69	15.37	30.74	76.86	153.74	307.43	768.56	
2.10	1.45	2.90	7.24	14.48	28.95	72.38	144.78	289.51	723.78	
2.15	1.37	2.74	6.84	13.68	27.36	68.39	136.81	273.57	683.92	
2.20	1.30	2.59	6.48	12.96	25.93	64.82	129.67	259.29	648.23	
2.25	1.23	2.46	6.16	12.32	24.64	61.61	123.23	246.43	616.07	
2.30	1.17	2.35	5.87	11.74	23.48	58.70	117.41	234.78	586.96	
2.35	1.12	2.24	5.60	11.21	22.42	56.05	112.11	224.19	560.47	
2.40	1.07	2.15	5.36	10.73	21.45	53.63	107.27	214.51	536.27	
2.45	1.03	2.06	5.14	10.28	20.56	51.41	102.83	205.63	514.07	
2.50	0.99	1.97	4.94	9.87	19.75	49.36	98.74	197.46	493.64	
2.55	0.95	1.90	4.75	9.50	18.99	47.48	94.97	189.91	474.77	
2.60	0.91	1.83	4.57	9.15	18.29	45.73	91.47	182.92	457.29	914.58
2.65	0.88	1.76	4.41	8.82	17.64	44.11	88.22	176.42	441.05	882.10
2.70	0.85	1.70	4.26	8.52	17.04	42.59	85.19	170.37	425.93	851.85
2.75	0.82	1.65	4.12	8.24	16.47	41.18	82.37	164.72	411.80	823.61
2.80	0.80	1.59	3.99	7.97	15.94	39.86	79.73	159.44	398.59	797.18
2.85	0.77	1.54	3.86	7.72	15.45	38.62	77.25	154.48	386.19	772.39
2.90	0.75	1.50	3.75	7.49	14.98	37.45	74.92	149.82	374.55	749.10
2.95	0.73	1.45	3.64	7.27	14.54	36.36	72.72	145.43	363.58	727.17
3.00	0.71	1.41	3.53	7.06	14.13	35.32	70.65	141.30	353.24	706.48
3.05	0.69	1.37	3.43	6.87	13.74	34.35	68.70	137.39	343.47	686.95
3.10	0.67	1.34	3.34	6.68	13.37	33.42	66.85	133.69	334.23	668.46

External Resistor Divider Table (contd.)

R1 (K Ohm)	1	2	5	10	20	50	100	200	500	1000
Vout	R2(kohm)=(1.242*R1(kohm))/(Vout-1.242)									
3.15	0.65	1.30	3.25	6.51	13.02	32.55	65.09	130.19	325.47	650.94
3.20	0.63	1.27	3.17	6.34	12.69	31.72	63.43	126.86	317.16	634.32
3.25	0.62	1.24	3.09	6.19	12.37	30.93	61.85	123.71	309.26	618.53
3.30	0.60	1.21	3.02	6.03	12.07	30.17	60.35	120.70	301.75	603.50
3.35	0.59	1.18	2.95	5.89	11.78	29.46	58.92	117.84	294.59	589.18
3.40	0.58	1.15	2.88	5.76	11.51	28.78	57.55	115.11	287.77	575.53
3.45	0.56	1.13	2.81	5.63	11.25	28.13	56.25	112.50	281.25	562.50
3.50	0.55	1.10	2.75	5.50	11.00	27.50	55.00	110.01	275.02	550.04
3.55	0.54	1.08	2.69	5.38	10.76	26.91	53.81	107.63	269.06	538.13
3.60	0.53	1.05	2.63	5.27	10.53	26.34	52.67	105.34	263.36	526.72
3.65	0.52	1.03	2.58	5.16	10.32	25.79	51.58	103.16	257.89	515.78
3.70	0.51	1.01	2.53	5.05	10.11	25.26	50.53	101.06	252.64	505.29
3.75	0.50	0.99	2.48	4.95	9.90	24.76	49.52	99.04	247.61	495.22
3.80	0.49	0.97	2.43	4.86	9.71	24.28	48.55	97.11	242.77	485.54
3.85	0.48	0.95	2.38	4.76	9.52	23.81	47.62	95.25	238.11	476.23
3.90	0.47	0.93	2.34	4.67	9.35	23.36	46.73	93.45	233.63	467.27
3.95	0.46	0.92	2.29	4.59	9.17	22.93	45.86	91.73	229.32	458.64
4.00	0.45	0.90	2.25	4.50	9.01	22.52	45.03	90.07	225.16	450.33
4.05	0.44	0.88	2.21	4.42	8.85	22.12	44.23	88.46	221.15	442.31
4.10	0.43	0.87	2.17	4.35	8.69	21.73	43.46	86.91	217.28	434.57
4.15	0.43	0.85	2.14	4.27	8.54	21.35	42.71	85.42	213.55	427.10
4.20	0.42	0.84	2.10	4.20	8.40	20.99	41.99	83.98	209.94	419.88
4.25	0.41	0.83	2.06	4.13	8.26	20.64	41.29	82.58	206.45	412.90
4.30	0.41	0.81	2.03	4.06	8.12	20.31	40.61	81.23	203.07	406.15
4.35	0.40	0.80	2.00	4.00	7.99	19.98	39.96	79.92	199.81	399.61
4.40	0.39	0.79	1.97	3.93	7.87	19.66	39.33	78.66	196.64	393.29
4.45	0.39	0.77	1.94	3.87	7.74	19.36	38.72	77.43	193.58	387.16
4.50	0.38	0.76	1.91	3.81	7.62	19.06	38.12	76.24	190.61	381.22
4.55	0.38	0.75	1.88	3.75	7.51	18.77	37.55	75.09	187.73	375.45
4.60	0.37	0.74	1.85	3.70	7.40	18.49	36.99	73.97	184.93	369.86
4.65	0.36	0.73	1.82	3.64	7.29	18.22	36.44	72.89	182.22	364.44
4.70	0.36	0.72	1.80	3.59	7.18	17.96	35.92	71.83	179.58	359.17
4.75	0.35	0.71	1.77	3.54	7.08	17.70	35.40	70.81	177.02	354.05
4.80	0.35	0.70	1.75	3.49	6.98	17.45	34.91	69.81	174.54	349.07
4.85	0.34	0.69	1.72	3.44	6.88	17.21	34.42	68.85	172.12	344.24
4.90	0.34	0.68	1.70	3.40	6.79	16.98	33.95	67.91	169.76	339.53
4.95	0.33	0.67	1.67	3.35	6.70	16.75	33.50	66.99	167.48	334.95
5.00	0.33	0.66	1.65	3.30	6.61	16.52	33.05	66.10	165.25	330.49

Note: Small load(greater than 2 mA) is necessary as R1 or R2 is larger than 50 K Ohm. Otherwise, outputvoltage probably cannot be pulled down to 0 V on disable mode.

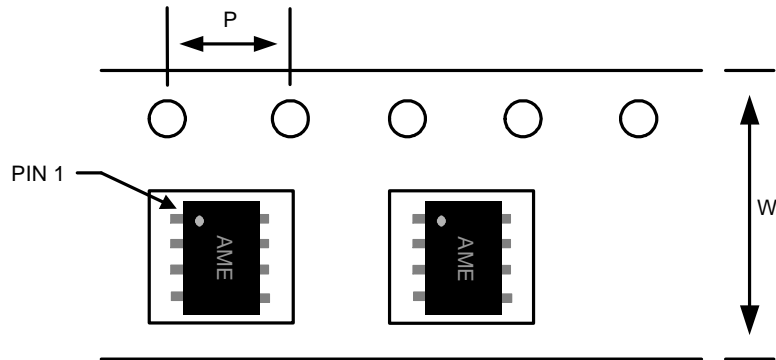
■ Tape and Reel Dimension
SOP-8

Carrier Tape, Number of Components Per Reel and Reel Size

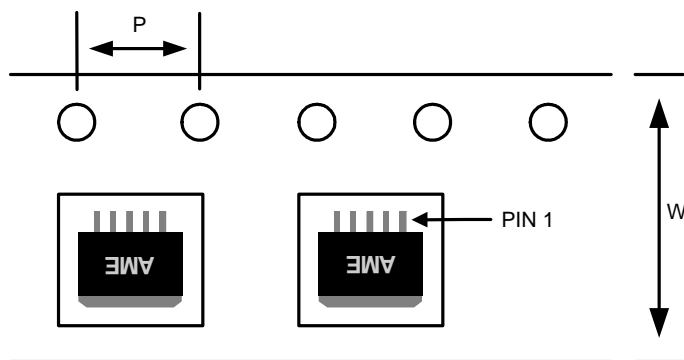
Package	Carrier Width (W)	Pitch (P)	Part Per Full Reel	Reel Size
SOP-8	12.0±0.1 mm	4.0±0.1 mm	2500pcs	330±1 mm

TO-263-5

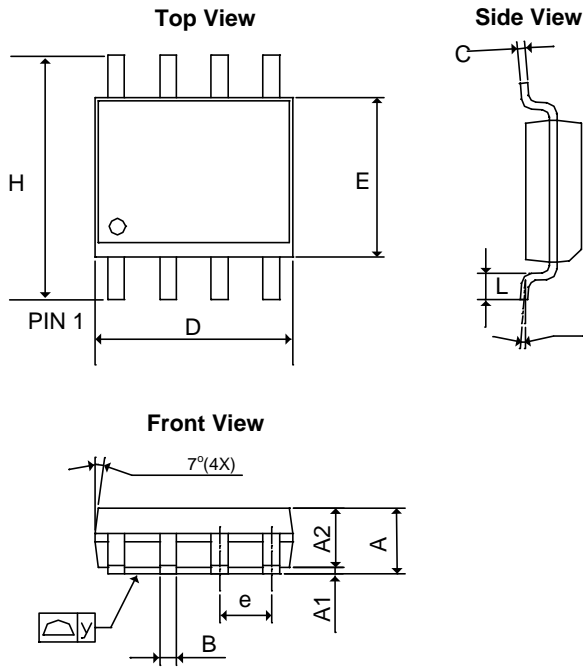
Carrier Tape, Number of Components Per Reel and Reel Size

Package	Carrier Width (W)	Pitch (P)	Part Per Full Reel	Reel Size
TO-263-5	24.0±0.1 mm	4.0±0.1 mm	800pcs	330±1 mm

■ Package Dimension
SOP-8

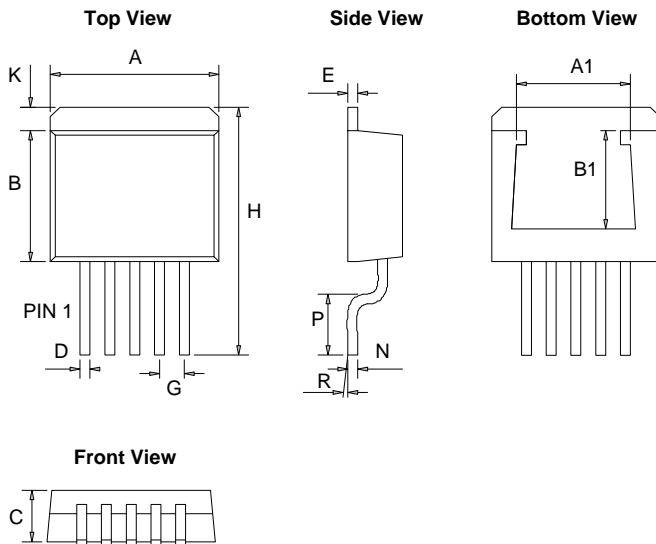
SYMBOLS	MILLIMETERS		INCHES	
	MIN	MAX	MIN	MAX
A	1.35	1.75	0.05315	0.0689
A ₁	0.10	0.30	0.00394	0.01181
A ₂	1.473 REF		0.05799 REF	
B	0.33	0.51	0.01299	0.02008
C	0.19	0.25	0.00748	0.00984
D	4.80	5.33	0.18898	0.20984
E	3.80	4.00	0.14961	0.15748
e	1.27 BSC		0.05000 BSC	
L	0.40	1.27	0.01575	0.05000
H	5.80	6.30	0.22835	0.24803
y	-	0.10	-	0.00394
q	0°	8°	0°	8°

TO-263-5

SYMBOLS	MILLIMETERS		INCHES	
	MIN	MAX	MIN	MAX
A	10.050	10.668	0.396	0.420
B	8.280	9.169	0.326	0.361
C	4.310	4.670	0.170	0.184
D	0.660	0.910	0.026	0.036
E	1.140	1.400	0.045	0.055
G	1.70 REF		0.067 REF	
H	14.600	15.875	0.575	0.625
K	1.143	1.680	0.045	0.066
N	0.330	0.580	0.013	0.023
P	2.280	2.800	0.090	0.110
R	0°	8°	0°	8°
A ₁	7.50	7.70	0.295	0.303
B ₁	5.80	6.45	0.228	0.254



www.ame.com.tw
E-Mail: sales@ame.com.tw

Life Support Policy:

These products of AME, Inc. are not authorized for use as critical components in life-support devices or systems, without the express written approval of the president of AME, Inc.

AME, Inc. reserves the right to make changes in the circuitry and specifications of its devices and advises its customers to obtain the latest version of relevant information.

© AME, Inc. , November 2008

Document: 2013-DS8816-H.04

Corporate Headquarter

AME, Inc.

2F, 302 Rui-Guang Road, Nei-Hu District

Taipei 114, Taiwan .

Tel: 886 2 2627-8687

Fax: 886 2 2659-2989