

### Features

- 8192 x 8 bit static CMOS RAM
- 250 and 500 ns Access Times
- Common data inputs and data outputs
- Three-state outputs
- Typ. operating supply current:  
250 ns: 12 mA  
500 ns: 7 mA
- Standby current < 5  $\mu$ A
- Standby current at 25 °C and 3.3 V: typ. 50 nA
- TTL/CMOS-compatible
- Automatic reduction of power dissipation in long Read or Write cycles
- Power supply voltage 3.3 V
- Operating temperature ranges  
0 to 70 °C  
-25 to 85 °C  
-40 to 85 °C
- Quality assessment according to CECC 90000, CECC 90100 and CECC 90111
- ESD protection > 2000 V (MIL STD 883C M3015.7)
- Latch-up immunity > 100 mA

- Packages: PDIP28(600 mil)  
SOP28 (330 mil)

### Description

The UL6264A is a static RAM manufactured using a CMOS process technology with the following operating modes:

- Read                      - Standby
- Write                     - Data Retention

The memory array is based on a 6-transistor cell.

The circuit is activated by the rising edge of E2 (at  $\overline{E1} = L$ ) or the falling edge of  $\overline{E1}$  (at E2 = H). The address and control inputs open simultaneously. According to the information of  $\overline{W}$  and  $\overline{G}$  the data inputs, or outputs, are active. In the active state  $\overline{E1} = L$  and E2 = H, each address change leads to a new Read or Write cycle. In a Read cycle, the data outputs are activated by the falling edge of  $\overline{G}$ , afterwards the data word read will be available at the outputs

DQ0 - DQ7. After the address

change, the data outputs go High-Z until the new read information is available. The data outputs have no preferred state. If the memory is driven by CMOS levels in the active state, and if there is no change of the address, data input and control signals  $\overline{W}$  or  $\overline{G}$ , the operating current (at  $I_O = 0$  mA) drops to the value of the operating current in the Standby mode. The Read cycle is finished by the falling edge of E2 or  $\overline{W}$ , or by the rising edge of  $\overline{E1}$ , respectively.

Data retention is guaranteed down to 2 V.

With the exception of E2, all inputs consist of NOR gates, so that no pull-up/pull-down resistors are required. This gate circuit allows to achieve low power standby requirements by activation with TTL-levels too.

If the circuit is inactivated by E2 = L, the standby current (TTL) drops to 100  $\mu$ A typ.

### Pin Configuration

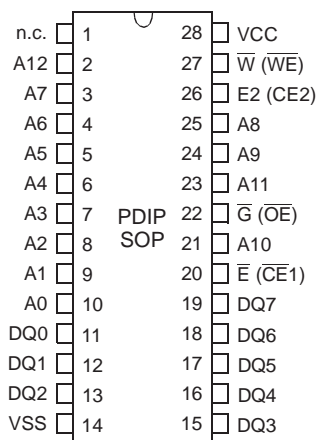

Top View

### Pin Description

Signal Name	Signal Description
A0 - A12	Address Inputs
DQ0 - DQ7	Data In/Out
$\overline{E1}$	Chip Enable 1
E2	Chip Enable 2
$\overline{G}$	Output Enable
$\overline{W}$	Write Enable
VCC	Power Supply Voltage
VSS	Ground
n.c.	not connected

# UL6264A

## Block Diagram

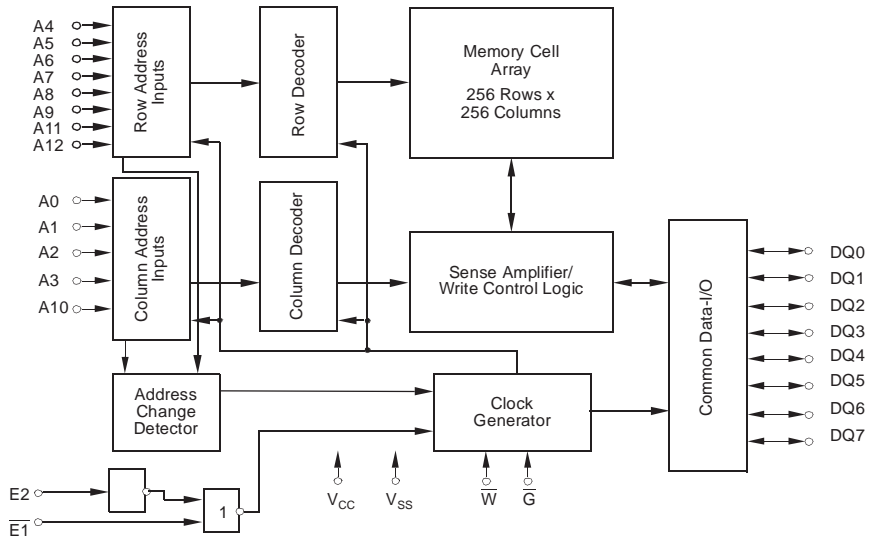

## Truth Table

Operating Mode	$\overline{E1}$	E2	$\overline{W}$	$\overline{G}$	DQ0 - DQ7
Standby/not selected	*	L	*	*	High-Z
	H	*	*	*	High-Z
Internal Read	L	H	H	H	High-Z
Read	L	H	H	L	Data Outputs Low-Z
Write	L	H	L	*	Data Inputs High-Z

\* H or L

## Characteristics

All voltages are referenced to  $V_{SS} = 0$  V (ground).

All characteristics are valid in the power supply voltage range and in the operating temperature range specified.

Dynamic measurements are based on a rise and fall time of  $\leq 5$  ns, measured between 10 % and 90 % of  $V_I$ , as well as input levels of  $V_{IL} = 0$  V and  $V_{IH} = 3$  V. The timing reference level of all input and output signals is 1.5 V, with the exception of the  $t_{dis}$ -times, in which cases transition is measured  $\pm 200$  mV from steady-state voltage.

Maximum Ratings	Symbol	Min.	Max.	Unit
Power Supply Voltage	$V_{CC}$	-0.3	7	V
Input Voltage	$V_I$	-0.3	$V_{CC} + 0.5$	V
Output Voltage	$V_O$	-0.3	$V_{CC} + 0.5$	V
Power Dissipation	$P_D$		1	W
Operating Temperature	C-Type	$T_a$	0	$^{\circ}\text{C}$
	G-Type		-25	$^{\circ}\text{C}$
	K-Type		-40	$^{\circ}\text{C}$
Storage Temperature	$T_{stg}$	-55	125	$^{\circ}\text{C}$

Recommended Operating Conditions	Symbol	Conditions	Min.	Max.	Unit
Power Supply Voltage	$V_{CC}$		3.0	3.6	V
Data Retention Voltage	$V_{CC(DR)}$		2.0		V
Input Low Voltage*	$V_{IL}$		-0.3	0.8	V
Input High Voltage	$V_{IH}$		2.0	$V_{CC} + 0.3$	V

\* -2 V at Pulse Width 10 ns

Electrical Characteristics	Symbol	Conditions	Min.	Max.	Unit
Supply Current - Operating Mode	$I_{CC(OP)}$	$V_{CC} = 3.6\text{ V}$ $V_{IL} = 0.8\text{ V}$ $V_{IH} = 2.0\text{ V}$ $t_{cW} = 500\text{ ns}$ $t_{cF} = 250\text{ ns}$		20 30	mA mA
Supply Current - Standby Mode (CMOS level)	$I_{CC(SB)}$	$V_{CC} = 3.6\text{ V}$ $V_{E1} = V_{E2} = V_{CC} - 0.2\text{ V}$		5	$\mu\text{A}$
Supply Current - Standby Mode (TTL level)	$I_{CC(SB)1}$	$V_{CC} = 3.6\text{ V}$ $V_{E1} = V_{E2} = 2.0\text{ V}$		2 (typ. 0.7)	mA
Output High Voltage	$V_{OH}$	$V_{CC} = 3.0\text{ V}$ $I_{OH} = -1.0\text{ mA}$	2.4		V
Output Low Voltage	$V_{OL}$	$V_{CC} = 3.0\text{ V}$ $I_{OL} = 2.0\text{ mA}$		0.4	V
Input High Leakage Current	$I_{IH}$	$V_{CC} = 3.6\text{ V}$ $V_{IH} = 3.6\text{ V}$		1	$\mu\text{A}$
Input Low Leakage Current	$I_{IL}$	$V_{CC} = 3.6\text{ V}$ $V_{IL} = 0\text{ V}$	-1		$\mu\text{A}$
Output High Current	$I_{OH}$	$V_{CC} = 3.0\text{ V}$ $V_{OH} = 2.4\text{ V}$		-1	mA
Output Low Current	$I_{OL}$	$V_{CC} = 3.0\text{ V}$ $V_{OL} = 0.4\text{ V}$	2.0		mA
Output Leakage Current High at Three-State Outputs	$I_{OHZ}$	$V_{CC} = 3.6\text{ V}$ $V_{OH} = 3.6\text{ V}$		1	$\mu\text{A}$
Low at Three-State Outputs	$I_{OLZ}$	$V_{CC} = 3.6\text{ V}$ $V_{OL} = 0\text{ V}$	-1		$\mu\text{A}$

# UL6264A

Switching Characteristics	Symbol		Min.		Max.		Unit
	Alt.	IEC	25	50	25	50	
Time to Output in Low-Z	$t_{LZ}$	$t_{t(QX)}$	20	20			ns
$\bar{G}$ LOW to Output in Low-Z	$t_{OLZ}$	$t_{t(G(QX))}$	10	10			ns
Cycle Time Write Cycle Time Read Cycle Time	$t_{WC}$ $t_{RC}$	$t_{cW}$ $t_{cR}$	250 250	500 500			ns ns
Access Time $\bar{E1}$ LOW or E2 HIGH to Data Valid $\bar{G}$ LOW to Data Valid Address to Data Valid	$t_{ACE}$ $t_{OE}$ $t_{AA}$	$t_{a(E)}$ $t_{a(G)}$ $t_{a(A)}$	- - -	- - -	250 100 250	500 100 500	ns ns ns
Pulse Widths Write Pulse Width Chip Enable to End of Write	$t_{WP}$ $t_{CW}$	$t_{w(W)}$ $t_{w(E)}$	120 180	150 210			ns ns
Setup Times Address Setup Time Chip Enable to End of Write Write Pulse Width Data Setup Time	$t_{AS}$ $t_{CW}$ $t_{WP}$ $t_{DS}$	$t_{su(A)}$ $t_{su(E)}$ $t_{su(W)}$ $t_{su(D)}$	0 180 120 80	0 210 150 100			ns ns ns ns
Data Hold Time Address Hold Time from End of Write	$t_{DH}$ $t_{AH}$	$t_{h(D)}$ $t_{h(A)}$	0 0	0 0			ns ns
Output Hold Time from Address Change	$t_{OH}$	$t_{v(A)}$	20	20			ns
$\bar{E1}$ HIGH or E2 LOW to Output in High-Z $\bar{W}$ LOW to Output in High-Z $\bar{G}$ HIGH to Output in High-Z	$t_{HZCE}$ $t_{HZWE}$ $t_{HZOE}$	$t_{dis(E)}$ $t_{dis(W)}$ $t_{dis(G)}$	0 0 0	0 0 0	60 60 40	60 60 40	ns ns ns

## Data Retention Mode $\bar{E1}$ -Controlled

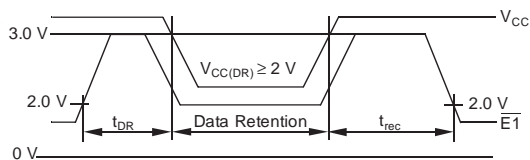

$$V_{E2(DR)} \geq V_{CC(DR)} - 0.2 \text{ V or } V_{E2(DR)} \leq 0.2 \text{ V}$$

$$V_{CC(DR)} - 0.2 \text{ V} \leq V_{\bar{E1}(DR)} \leq V_{CC(DR)} + 0.3 \text{ V}$$

## Data Retention Mode E2-Controlled

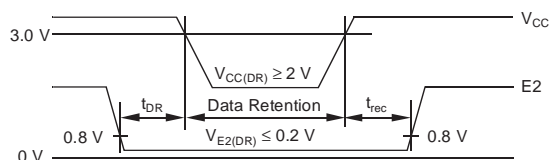

Chip Deselect to Data Retention Time  
Operating Recovery Time

$t_{DR}$ : min 0 ns  
 $t_{rec}$ : min  $t_{cR}$

## Test Configuration for Functional Check

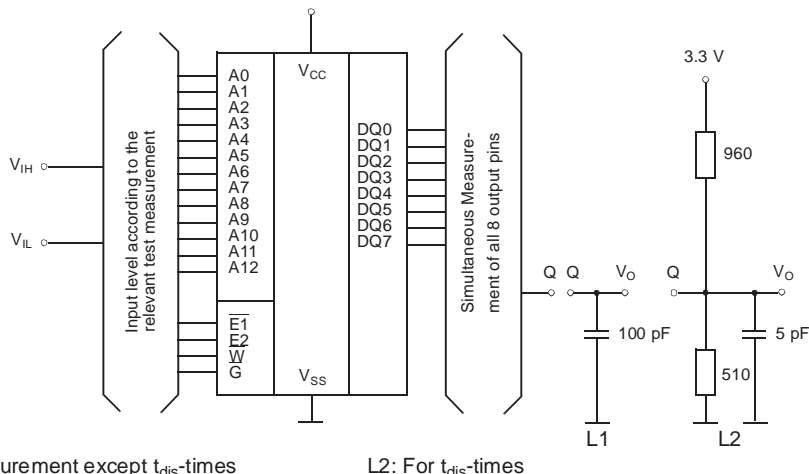

L1: For dynamic measurement except  $t_{dis}$ -times

L2: For  $t_{dis}$ -times

Capacitance	Conditions	Symbol	Min.	Max.	Unit
Input Capacitance	$V_{CC} = 3.3\text{ V}$ $V_I = V_{SS}$	$C_I$		8	pF
Output Capacitance	$f = 1\text{ MHz}$ $T_a = 25\text{ }^\circ\text{C}$	$C_O$		10	pF

All pins not under test must be connected with ground by capacitors.

## IC Code Numbers

Example

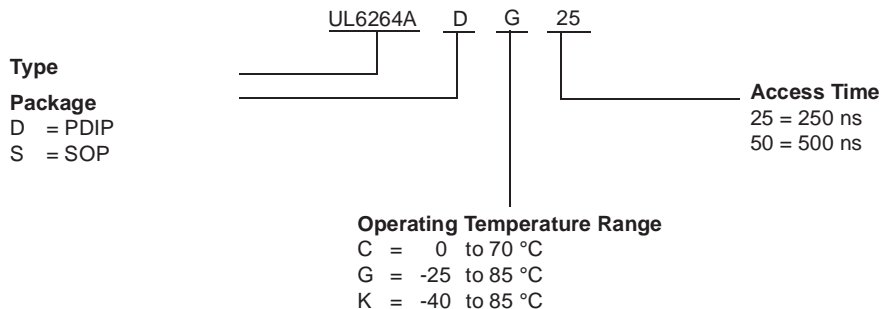

The date of manufacture is given by the 4 last digits of the mark, the first 2 digits indicating the year, and the last 2 digits the calendar week.

## Read Cycle 1 (during Read Cycle: $\overline{E1} = \overline{G} = V_{IL}$ , $E2 = \overline{W} = V_{IH}$ )

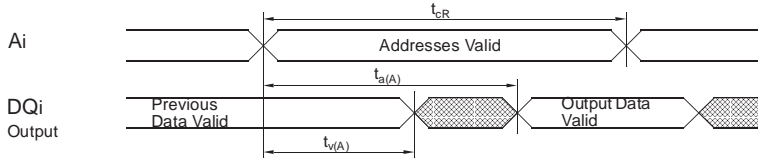

## Read Cycle 2 (during Read Cycle: $\overline{W} = V_{IH}$ )

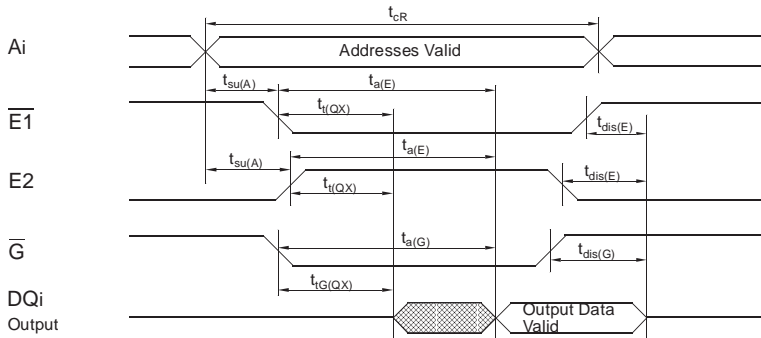

## Write Cycle 1 ( $\overline{W}$ -controlled)

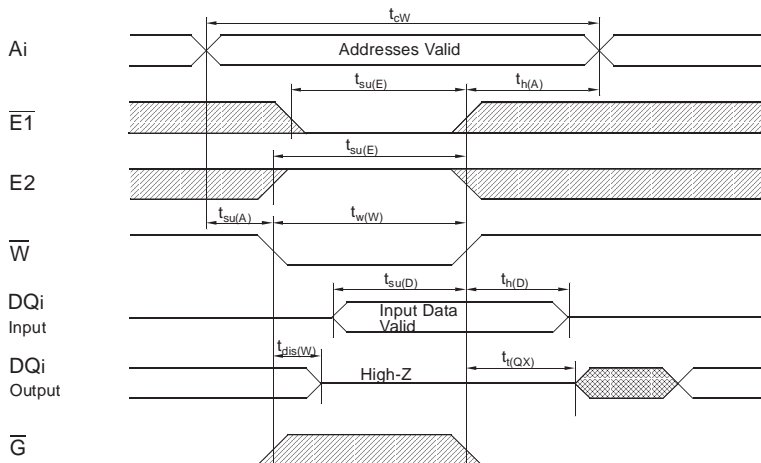

Write Cycle 2 ( $\overline{E1}$ -controlled)

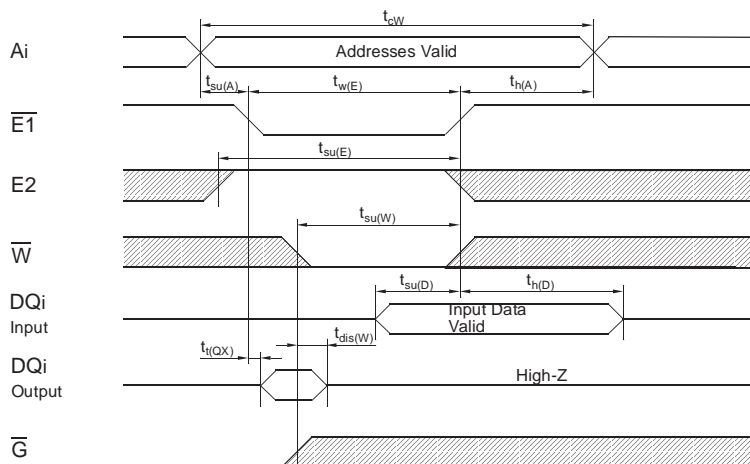

Write Cycle 3 (E2-controlled)

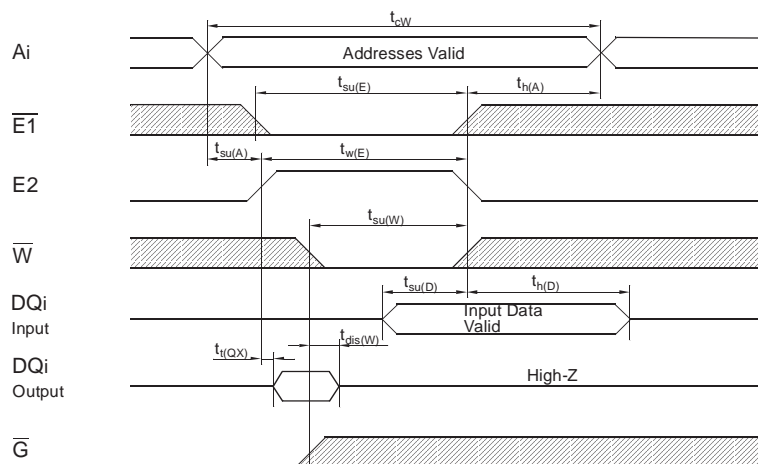

undefined



L- or H-Level



---

## **LIFE SUPPORT POLICY**

ZMD products are not designed, intended, or authorized for use as components in systems intended for surgical implant into the body, or other applications intended to support or sustain life, or for any other application in which the failure of the ZMD product could create a situation where personal injury or death may occur. Components used in life-support devices or systems must be expressly authorized by ZMD for such purpose.

## **LIMITED WARRANTY**

The information in this document has been carefully checked and is believed to be reliable. However Zentrum Mikroelektronik Dresden GmbH (ZMD) makes no guarantee or warranty concerning the accuracy of said information and shall not be responsible for any loss or damage of whatever nature resulting from the use of, or reliance upon it. The information in this document describes the type of component and shall not be considered as assured characteristics.

ZMD does not guarantee that the use of any information contained herein will not infringe upon the patent, trademark, copyright, mask work right or other rights of third parties, and no patent or licence is implied hereby. This document does not in any way extent ZMD's warranty on any product beyond that set forth in its standard terms and conditions of sale.

ZMD reserves terms of delivery and reserves the right to make changes in the products or specifications, or both, presented in this publication at any time and without notice.