

## LOW DROPOUT REGULATOR

## FEATURES

- Up to 5 A Output Current Capability with External PNP Transistor
- Internal Short Circuit Protection
- Excellent Load Regulation
- CMOS/TTL-Compatible On/Off Switch
- Internal Reverse Bias Current Protection Switch
- Internal Thermal Shutdown
- Broad Operating Voltage Range
- High Impedance  $V_{SENSE}$  Pin (Off Mode)
- Continuous and Pulsed Current Modes

## DESCRIPTION

The TK732xx is a controller IC for a low dropout voltage regulator. The TK732xx and the external PNP power transistor provide standard output voltages from 2 to 11 V and output current from 100 mA to 5 A. By utilizing an external PNP power transistor, low dropout voltage at high current can be readily achieved. The internal electronic switch can be controlled by TTL or CMOS logic levels. The device is in the "on" state when the control pin is pulled to a high logic level. A pin for a bypass capacitor, which connects to the internal circuitry, is provided to lower the overall output noise level.

The current limit characteristics can be configured as continuous (constant current) or pulsed (cycling). An internal thermal shutdown circuit limits the junction temperatures to below 150 °C. In the "off" mode, the output of the regulator becomes a high impedance. This prevents the output capacitor from being rapidly discharged for backup to the load.

## APPLICATIONS

- Battery Powered Systems
- Cellular/Cordless Telephones
- Radio Control Systems
- Wireless Communications Systems
- Portable Instrumentations
- Portable Computers
- Personal Digital Assistants
- Local Area Network (LAN) Receivers
- Lithium Ion Battery Chargers
- Power Recovery for Microprocessors

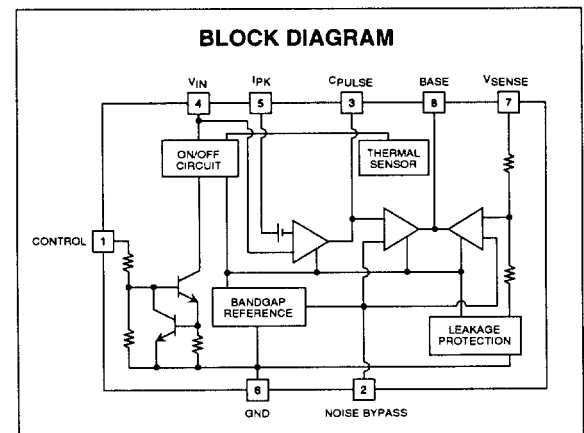
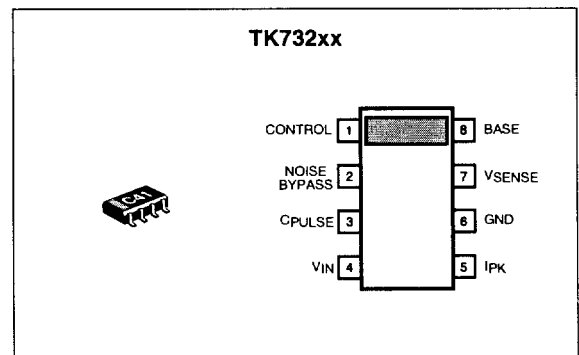

## ORDERING INFORMATION

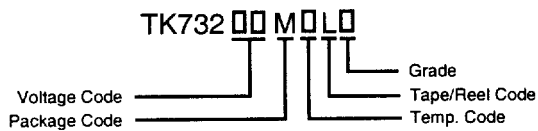

VOLTAGE CODE	TAPE/REEL CODE L: Tape Left	PACKAGE CODE M: SOT-23L-8
20 = 2.0 V *	32 = 32 V	44 = 4.4 V
21 = 2.1 V *	33 = 33 V	45 = 4.5 V
22 = 2.2 V *	34 = 34 V	46 = 4.6 V
23 = 2.3 V *	35 = 35 V	47 = 4.7 V
24 = 2.4 V	36 = 3.6 V	48 = 4.8 V
25 = 2.5 V	37 = 3.7 V	49 = 4.9 V
26 = 2.6 V	38 = 3.8 V	50 = 5.0 V
27 = 2.7 V	39 = 3.9 V	55 = 5.5 V *
28 = 2.8 V	40 = 4.0 V	70 = 7.0 V **
29 = 2.9 V	41 = 4.1 V	80 = 8.0 V
30 = 3.0 V	42 = 4.2 V	11 = 11.0 V
31 = 3.1 V	43 = 4.3 V	

TEMP. RANGE      GRADE  
C: -30 to 80 °C \*\*      None: Standard ±2%  
I: -40 to 85 °C      H: High (Special) \*\*\*

\* Unavailable with I Rank  
\*\* unless Otherwise Specified  
\*\*\* TK73241MCLH, TK73242MCLH Available Only

**ABSOLUTE MAXIMUM RATINGS (STANDARD DEVICES) (NOTE 6)**

Supply Voltage Range .....	19 V	Operating Temperature Range .....	-30 to +80 °C
Power Dissipation (Note 1) .....	600 mW	Extended Temperature Range .....	-40 to +85 °C
Reverse Bias Voltage Range .....	6 V	Operating Voltage Range .....	1.8 to 14.0 V
Noise Bypass Pin Terminal Voltage Range .....	5 V	Junction Temperature .....	150 °C
Control Pin Terminal Voltage Range .....	14 V	Lead Soldering Temperature (10 s) .....	235 °C
Storage Temperature Range .....	-55 to +150 °C		

**TK732xx ELECTRICAL CHARACTERISTICS (STANDARD DEVICES)**

Test conditions:  $V_{IN} = V_{OUT(TYP)} + 1 V$ ,  $T_A = 25 °C$ , unless otherwise specified.

SYMBOL	PARAMETER	TEST CONDITIONS	MIN	TYP	MAX	UNITS
$I_Q$	Quiescent Current	$I_{OUT} = 0 mA$ , Excluding $I_{CONT}$		250	360	$\mu A$
$I_{STBY}$	Standby Current	$V_{IN} = 8 V$ , Output OFF			0.1	$\mu A$
$I_{R(LEAK)}$	Reverse Bias Leakage (Note 5)	$V_R = 5 V$ , Excluding External Transistor, Output OFF		2	50	nA
$I_{OUT}$	Output Current	External Transistor Dependent		N/A		A
$V_{OUT}$	Output Voltage	$I_{OUT} = 30 mA$ , See Table 1				V
$V_{DROP}$	Dropout Voltage	External Transistor Dependent		N/A		V
Line Reg	Line Regulation	$V_{IN} = V_{OUT(TYP)} + 1 V$ to $V_{OUT(TYP)} + 6 V$ (Note 2)		3.0	20	mV
Load Reg	Load Regulation	External Transistor Dependent		10		mV
$I_{BASE(L)}$	Base Current LOW	$1.8 V \leq V_{IN} \leq 4 V$	15			mA
$I_{BASE(H)}$	Base Current HIGH	$4.1 V \leq V_{IN} \leq 12 V$	40			mA
$V_{SENSE}$	Current Limit Detect Voltage	Continuous Current Limit Mode	80	100	120	mV
		Pulse Current Limit Mode	70	90	110	mV
RR	Ripple Rejection	$f = 400 Hz$ , $C_L = 10 \mu F$ , $C_N = 0.1 \mu F$ , $V_{IN} = V_{OUT(TYP)} = 1.5 V$ , $I_{OUT} = 30 mA$ , $V_{RIPPLE} = 100 mV_{rms}$ , (Note 3)		57		dB
$V_{NO}$	Output Noise	$f = 1 kHz$ , BPF = 400 Hz to 30 kHz, (Note 3)		0.13		$\mu V/\sqrt{Hz}$
$I_{PULSE}$	$C_{PULSE}$ Pin Terminal Current	(Note 4)	15	25	45	$\mu A$
$\Delta V_{OUT} / \Delta T$	Temperature Coefficient			20		ppm/°C
$V_{ref}$	Reference Voltage			1.25		V

**CONTROL TERMINAL SPECIFICATIONS**

$I_{CONT}$	Control Current	$V_{CONT} = 1.8 V$ , Output ON		6.5	20	$\mu A$
$V_{CONT(ON)}$	Control Voltage (ON)	Output ON	1.8			V
$V_{CONT(OFF)}$	Control Voltage (OFF)	Output OFF			0.6	V

## TK732xx ELECTRICAL CHARACTERISTICS (STANDARD DEVICES) CONT.

Note 1: Power dissipation is 600 mW when mounted as recommended. Derate at 4.8 mW/°C for operation above 25 °C.

Note 2: Refer to: "Definition of Terms."

Note 3: Ripple rejection and noise voltage are affected by the value and characteristics of the capacitor used.

Note 4: This pin is used for Pulse Current Limit Mode. When selecting Continuous Current Limit Mode, this pin is connected to GND.

Note 5: Not applicable for  $V_{OUT} > 4.8$  V.

Note 6: The voltage applied to any pin must be greater than -0.4 V.

Gen. Note: Parameters with min. or max. values are 100% tested at  $T_A = 25$  °C.

## TK732xx ELECTRICAL CHARACTERISTICS (STANDARD DEVICES) TABLE 1

Test Conditions:  $V_{IN} = V_{OUT(TYP)} + 1$  V,  $I_{OUT} = 30$  mA,  $T_A = 25$  °C, unless otherwise specified.

Output Voltage	Voltage Code	Room Temp. Range ( $T_A = 25$ °C)		Full Temp. Range ( $T_A = -40$ to $+85$ °C) (Applies to "I" Rank Only)	
		$V_{OUT(MIN)}$	$V_{OUT(MAX)}$	$V_{OUT(MIN)}$	$V_{OUT(MAX)}$
2.0 V	20	1.940 V	2.060 V		
2.1 V	21	2.040 V	2.160 V		
2.2 V	22	2.140 V	2.260 V		
2.3 V	23	2.240 V	2.360 V		
2.4 V	24	2.340 V	2.460 V	2.300 V	2.500 V
2.5 V	25	2.440 V	2.560 V	2.400 V	2.600 V
2.6 V	26	2.540 V	2.660 V	2.500 V	2.700 V
2.7 V	27	2.640 V	2.760 V	2.600 V	2.800 V
2.8 V	28	2.740 V	2.860 V	2.700 V	2.900 V
2.9 V	29	2.840 V	2.960 V	2.800 V	3.000 V
3.0 V	30	2.940 V	3.060 V	2.900 V	3.100 V
3.1 V	31	3.040 V	3.160 V	3.000 V	3.200 V
3.2 V	32	3.140 V	3.260 V	3.095 V	3.305 V
3.3 V	33	3.240 V	3.360 V	3.190 V	3.410 V
3.4 V	34	3.335 V	3.465 V	3.290 V	3.510 V
3.5 V	35	3.435 V	3.565 V	3.385 V	3.615 V
3.6 V	36	3.535 V	3.665 V	3.485 V	3.720 V
3.7 V	37	3.630 V	3.770 V	3.580 V	3.820 V
3.8 V	38	3.725 V	3.875 V	3.675 V	3.925 V
3.9 V	39	3.825 V	3.975 V	3.770 V	4.030 V
4.0 V	40	3.920 V	4.080 V	3.870 V	4.130 V
4.1 V	41	4.020 V	4.180 V	3.965 V	4.235 V
4.2 V	42	4.120 V	4.280 V	4.060 V	4.335 V
4.3 V	43	4.215 V	4.385 V	4.160 V	4.440 V
4.4 V	44	4.315 V	4.485 V	4.255 V	4.545 V
4.5 V	45	4.410 V	4.590 V	4.350 V	4.645 V
4.6 V	46	4.510 V	4.690 V	4.450 V	4.750 V
4.7 V	47	4.605 V	4.795 V	4.545 V	4.850 V
4.8 V	48	4.705 V	4.895 V	4.640 V	4.955 V
4.9 V	49	4.800 V	5.000 V	4.740 V	5.060 V
5.0 V	50	4.900 V	5.100 V	4.835 V	5.165 V
5.5 V	55	5.390 V	5.610 V		
7.0 V	70	6.860 V	7.140 V		
6.0 V	80	7.840 V	8.160 V	7.745 V	8.265 V
11.0 V	11	10.78 V	11.22 V	10.650 V	11.365 V

**ABSOLUTE MAXIMUM RATINGS (SPECIAL DEVICES) (Note 6)**

Supply Voltage Range .....	19 V	Storage Temperature Range .....	-55 to +150 °C
Power Dissipation (Note 1) .....	600 mW	Operating Temperature Range .....	-10 to +60 °C
Reverse Bias Voltage Range .....	6 V	Operating Voltage Range .....	1.8 to 14.5 V
Noise Bypass Pin Terminal Voltage Range .....	5 V	Junction Temperature .....	150 °C
Control Pin Terminal Voltage Range .....	14 V	Lead Soldering Temperature (10 s) .....	235 °C

1

**TK73241MCLH, TK73242MCLH ELECTRICAL CHARACTERISTICS**Test conditions:  $V_{IN} = V_{OUT(TYP)} + 1\text{ V}$ ,  $T_A = 25\text{ °C}$ , unless otherwise specified.

SYMBOL	PARAMETER	TEST CONDITIONS	MIN	TYP	MAX	UNITS
$I_Q$	Quiescent Current	$I_{OUT} = 0\text{ mA}$ , Excluding $I_{CONT}$		240	300	$\mu\text{A}$
$I_{STBY}$	Standby Current	$V_{IN} = 8\text{ V}$ , Output OFF			0.1	$\mu\text{A}$
$I_{R(LEAK)}$	Reverse Bias Leakage (Note 5)	$V_R = 5\text{ V}$ , Excluding External Transistor, Output OFF		2	50	nA
$I_{OUT}$	Output Current	External Transistor Dependent		N/A		A
$V_{OUT}$	Output Voltage	$I_{OUT} = 30\text{ mA}$ , See Table 2				V
$V_{DROP}$	Dropout Voltage	External Transistor Dependent		N/A		V
Line Reg	Line Regulation	$V_{IN} = V_{OUT(TYP)} + 1\text{ V}$ to $V_{OUT(TYP)} + 6\text{ V}$ (Note 2)		3.0	20	mV
Load Reg	Load Regulation	External Transistor Dependent		10		mV
$I_{BASE}$	Base Current		50			mA
$V_{SENSE}$	Current Limit Detect Voltage	Continuous Current Limit Mode	85	100	115	mV
		Pulse Current Limit Mode	75	90	105	mV
RR	Ripple Rejection	$f = 400\text{ Hz}$ , $C_L = 10\text{ }\mu\text{F}$ , $C_N = 0.1\text{ }\mu\text{F}$ , $V_{IN} = V_{OUT(TYP)} = 1.5\text{ V}$ , $I_{OUT} = 30\text{ mA}$ , $V_{RIPPLE} = 100\text{ mVrms}$ , (Note 3)		57		dB
$V_{NO}$	Output Noise	$f = 1\text{ kHz}$ , BPF = 400 Hz to 30 kHz, (Note 3)		0.13		$\mu\text{V}/\sqrt{\text{Hz}}$
$I_{PULSE}$	$C_{PULSE}$ Pin Terminal Current	(Note 4)	15	25	45	$\mu\text{A}$
$\Delta V_{OUT}/\Delta T$	Temperature Coefficient			20		ppm/°C
$V_{ref}$	Reference Voltage			1.25		V
<b>CONTROL TERMINAL SPECIFICATIONS</b>						
$I_{CONT}$	Control Current	$V_{CONT} = 1.8\text{ V}$ , Output ON		6.5	20	A
$V_{CONT(ON)}$	Control Voltage (ON)	Output ON	1.8			V
$V_{CONT(OFF)}$	Control Voltage (OFF)	Output OFF			0.6	V

**TK73241MCLH, TK73242MCLH ELECTRICAL CHARACTERISTICS CONT.**

Note 1: Power dissipation is 600 mW when mounted as recommended. Derate at 4.8 mW/°C for operation above 25 °C.

Note 2: Refer to: "Definition of Terms."

Note 3: Ripple rejection and noise voltage are affected by the value and characteristics of the capacitor used.

Note 4: This pin is used for Pulse Current Limit Mode. When selecting Continuous Current Limit Mode, this pin is connected to GND.

Note 5: Not applicable for  $V_{OUT} > 4.8$  V.

Note 6: The voltage applied to any pin must be greater than -0.4 V.

Gen. Note: Parameters with min. or max. values are 100% tested at  $T_A = 25$  °C.

**TK73241MCLH, TK73242MCLH ELECTRICAL CHARACTERISTICS TABLE 2**

Test Conditions:  $V_{IN} = V_{OUT(TYP)} + 1$  V,  $I_{OUT} = 30$  mA,  $T_A = 25$  °C, unless otherwise specified.

Output Voltage	Voltage Code	Room Temp. Range ( $T_A = 25$ °C)		Full Temp. Range ( $T_A = -10$ to $+60$ °C)	
		$V_{OUT(MIN)}$	$V_{OUT(MAX)}$	$V_{OUT(MIN)}$	$V_{OUT(MAX)}$
4.1 V	41	4.067 V	4.133 V	4.050 V	4.150 V
4.2 V	42	4.167 V	4.233 V	4.150 V	4.250 V

TEST CIRCUIT

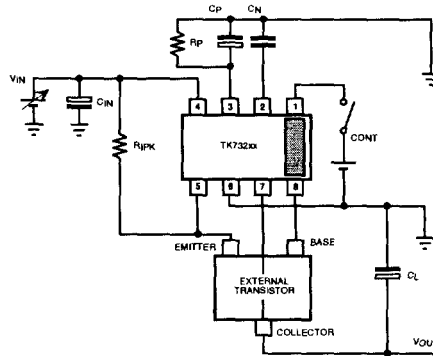

Note: Transistor: 2SB1115

$C_N = 0.1 \mu F$

$C_P = 0.1 \mu F$

$C_L = 4.7 \mu F$

$R_P = 330 k$

Continuous Current Limit Mode:

$I_{SET} (mA) = 100 mV / R_{IPK} (\Omega)$

Pulse Current Limit Mode:

$I_{SET} (mA) = 90 mV / R_{IPK} (\Omega)$

TYPICAL PERFORMANCE CHARACTERISTICS

$T_A = 25^\circ C$ , external transistor is 2SB1115(NEC), unless otherwise specified.

LINE REGULATION 1

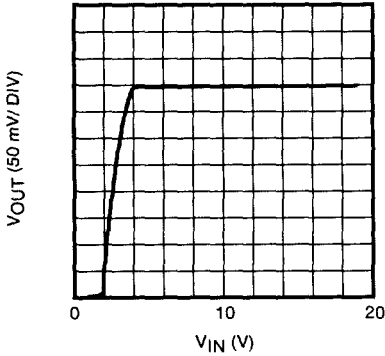

LINE REGULATION 2

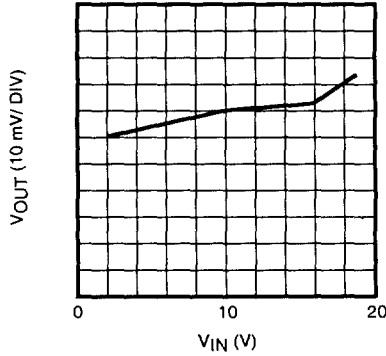

LOAD REGULATION

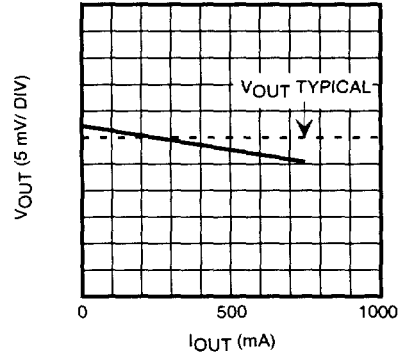

QUIESCENT CURRENT vs. OUTPUT VOLTAGE

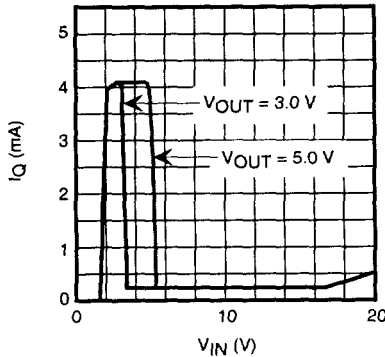

DROPOUT VOLTAGE vs. OUTPUT VOLTAGE

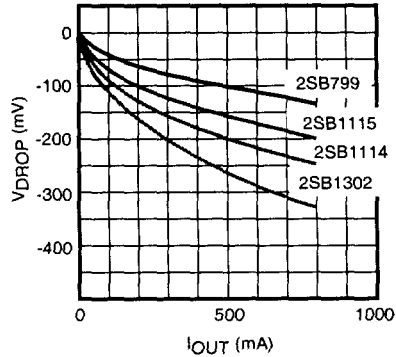

GROUND CURRENT vs. OUTPUT VOLTAGE

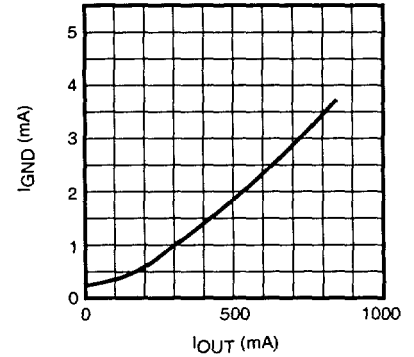

**TYPICAL PERFORMANCE CHARACTERISTICS (CONT.)**

$T_A = 25^\circ\text{C}$ , external transistor is 2SB1115(NEC), unless otherwise specified.

**CURRENT LIMIT DETECTOR VOLTAGE vs. INPUT VOLTAGE**

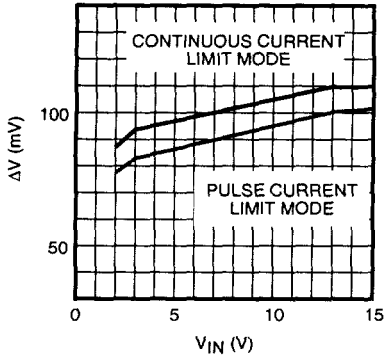

**BASE CURRENT DRIVE vs. INPUT VOLTAGE**

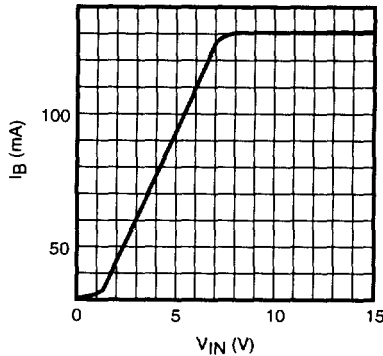

**REVERSE BIAS CURRENT (V\_IN = 0 TO 6 V)**

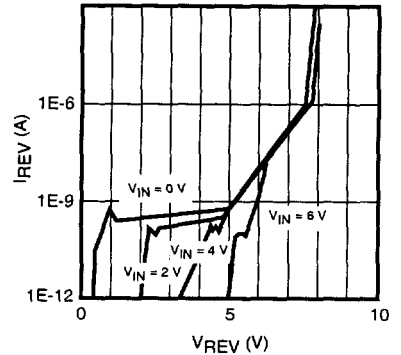

**QUIESCENT CURRENT vs. INPUT VOLTAGE (OFF MODE)**

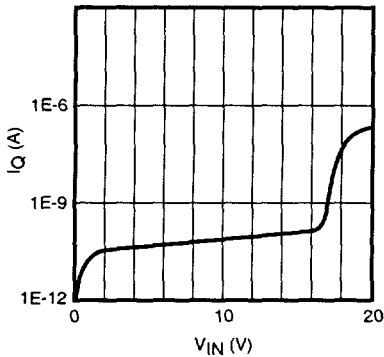

**RIPPLE REJECTION**

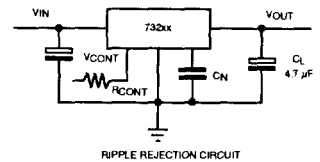
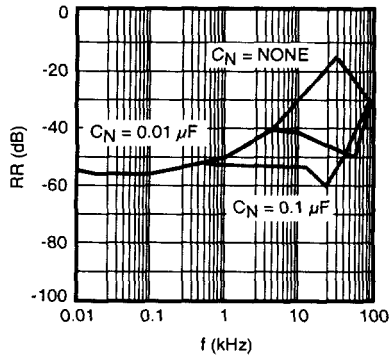

RIPPLE REJECTION CIRCUIT

**CONTROL CURRENT vs. TEMPERATURE**

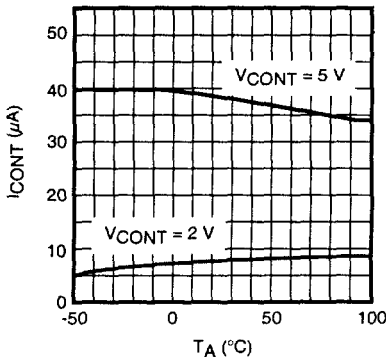

**CONTROL VOLTAGE (OUTPUT ON POINT) vs. TEMPERATURE**

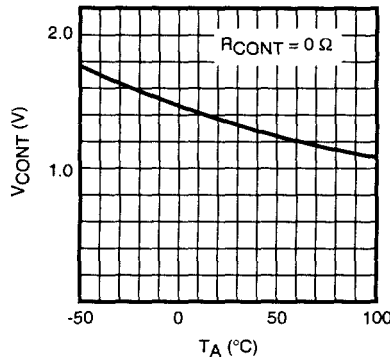

**OUTPUT VOLTAGE VARIATION vs. TEMPERATURE**

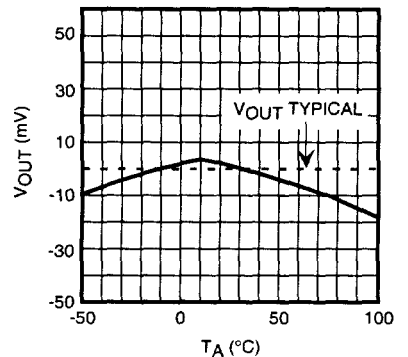

**TYPICAL PERFORMANCE CHARACTERISTICS (CONT.)**

$T_A = 25\text{ }^\circ\text{C}$ , external transistor is 2SB1115(NEC), unless otherwise specified.

1

**CONTROL PIN VOLTAGE vs. CONTROL CURRENT**

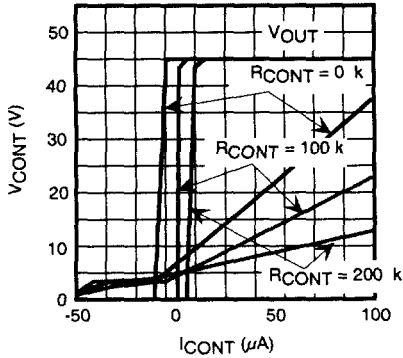

**ON/OFF TRANSIENT**

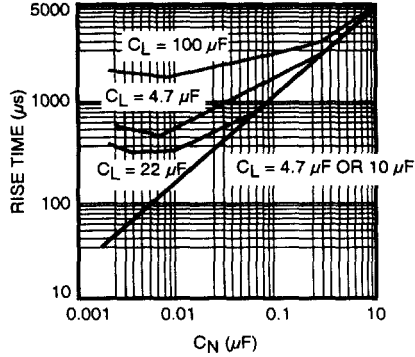

**ON/OFF STEP RESPONSE**

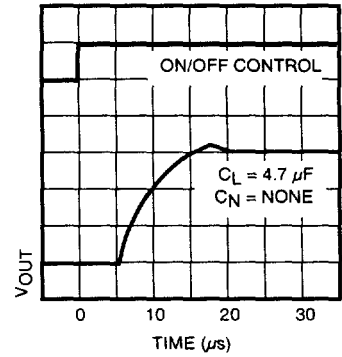

**LOAD CURRENT STEP RESPONSE**

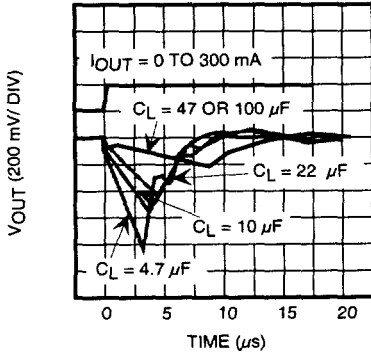

**LINE CURRENT STEP RESPONSE**

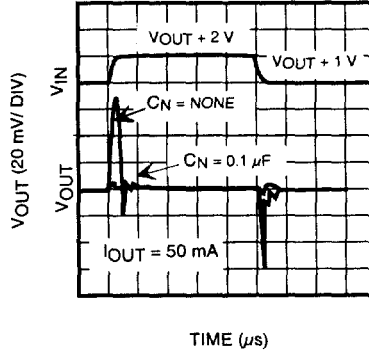



## DEFINITION AND EXPLANATION OF TECHNICAL TERMS

### OUTPUT VOLTAGE ( $V_{OUT}$ )

The output voltage is specified with  $V_{IN} = (V_{OUT(TYP)} + 1 \text{ V})$  and  $I_{OUT} = 30 \text{ mA}$ .

### DROPOUT VOLTAGE ( $V_{DROPO}$ )

The dropout voltage is the difference between the input voltage and the output voltage at which point the regulator starts to fall out of regulation. Below this value, the output voltage will fall as the input voltage is reduced. It is dependent upon the load current, the external transistor and the junction temperature.

### BASE CONTROL CURRENT ( $I_{BASE}$ )

The base control current is the drive current for the base of the external transistor.

### OUTPUT CURRENT ( $I_{OUT}$ )

The output current depends on the characteristics of the external transistor and current limit setting.

### LINE REGULATION (Line Reg)

Line regulation is the ability of the regulator to maintain a constant output voltage as the input voltage changes. The line regulation is specified as the input voltage is changed from  $V_{IN} = V_{OUT(TYP)} + 1 \text{ V}$  to  $V_{IN} = V_{OUT(TYP)} + 6 \text{ V}$ .

### LOAD REGULATION (Load Reg)

Load regulation is the ability of the regulator to maintain a constant output voltage as the load current changes. It is a pulsed measurement to minimize temperature effects. Load regulation depends on the external transistor.

### QUIESCENT CURRENT ( $I_Q$ )

The quiescent current is the current which flows through the ground terminal under no load conditions ( $I_{OUT} = 0 \text{ mA}$ ) and excludes the control pin current.

### GROUND CURRENT ( $I_{GND}$ )

Ground current is the current which flows through the ground pin(s). It is defined as  $I_{IN} - I_{OUT}$ , excluding control current.

### RIPPLE REJECTION RATIO (RR)

Ripple rejection is the ability of the regulator to attenuate the ripple content of the input voltage at the output. It is specified with 100 mVrms, 400 Hz superimposed on the input voltage, where  $V_{IN} = V_{OUT(TYP)} + 1.5 \text{ V}$ . The output decoupling capacitor is set to 10  $\mu\text{F}$ , the noise bypass capacitor is set to 0.1  $\mu\text{F}$ , and the load current is set to 30 mA. Ripple rejection is the ratio of the ripple content of the output vs. the input and is expressed in dB.

### STANDBY CURRENT ( $I_{STBY}$ )

Standby current is the current which flows into the regulator when the output is turned off by the control function ( $V_{CONT} = 0 \text{ V}$ ). It is measured with  $V_{IN} = 8 \text{ V}$  (9 V for the 8 V output device).

### REMOTE SENSING ( $V_{SENSE}$ )

The  $V_{SENSE}$  pin is the output voltage sensing pin. If the voltage drop to the load caused by the PCB etch resistance cannot be disregarded, the voltage drop can be compensated by connecting the  $V_{SENSE}$  pin as shown below.

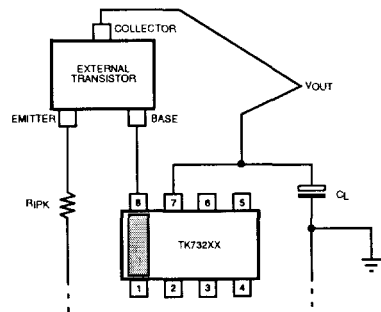

The length of the  $V_{SENSE}$  etch should be limited to 30 cm (11.8 in.) maximum.

## DEFINITION AND EXPLANATION OF TECHNICAL TERMS (CONT.)

### SENSOR CIRCUITS

#### Overcurrent Sensor

The overcurrent sensor protects the device if the output is shorted to ground.

#### Thermal Sensor

The thermal sensor protects the device if the junction temperature exceeds the safe value ( $T_j = 150\text{ }^\circ\text{C}$ ). This temperature rise can be caused by extreme heat, excessive power dissipation caused by large output voltage drops, or excessive output current. The regulator will shut off when the temperature exceeds the safe value. As the junction temperature decreases, the regulator will begin to operate again. Under sustained fault conditions, the regulator output will oscillate as the device turns off then resets. Damage may occur to the device under extreme fault conditions.

#### Reverse Voltage Protection

Reverse voltage protection prevents damage due to the output voltage being higher than the input voltage. This fault condition can occur when the output capacitor remains charged and the input is reduced to zero, or when an external voltage higher than the input voltage is applied to the output side.

### PACKAGE POWER DISSIPATION ( $P_D$ )

This is the power dissipation level at which the thermal sensor is activated. The IC contains an internal thermal sensor which monitors the junction temperature. When the junction temperature exceeds the monitor threshold of  $150\text{ }^\circ\text{C}$ , the IC is shut down. The junction temperature rises as the difference between the input power ( $V_{IN} \times I_{IN}$ ) and the output power ( $V_{OUT} \times I_{OUT}$ ) increases. The rate of temperature rise is greatly affected by the mounting pad configuration on the PCB, the board material, and the ambient temperature. When the IC mounting has good thermal conductivity, the junction temperature will be low even if the power dissipation is great. When mounted on the recommended mounting pad, the power dissipation of the SOT-23L-8 is increased to 600 mW. For operation at ambient temperatures over  $25\text{ }^\circ\text{C}$ , the power dissipation of the SOT-23L-8 device should be derated at  $4.8\text{ mW}/^\circ\text{C}$ . To determine the power dissipation for shutdown when mounted, attach the device on the actual PCB and

deliberately increase the output current (or raise the input voltage) until the thermal protection circuit is activated. Calculate the power dissipation of the device by subtracting the output power from the input power. These measurements should allow for the ambient temperature of the PCB. The value obtained from  $P_D / (150\text{ }^\circ\text{C} - T_A)$  is the derating factor. The PCB mounting pad should provide maximum thermal conductivity in order to maintain low device temperatures. As a general rule, the lower the temperature, the better the reliability of the device. The thermal resistance when mounted is expressed as follows:

$$T_j = \theta_{jA} \times P_D + T_A$$

For Toko ICs, the internal limit for junction temperature is  $150\text{ }^\circ\text{C}$ . If the ambient temperature ( $T_A$ ) is  $25\text{ }^\circ\text{C}$ , then:

$$150\text{ }^\circ\text{C} = \theta_{jA} \times P_D + 25\text{ }^\circ\text{C}$$

$$\theta_{jA} = 125\text{ }^\circ\text{C} / P_D$$

$P_D$  is the value when the thermal sensor is activated. A simple way to determine  $P_D$  is to calculate  $V_{IN} \times I_{IN}$  when the output side is shorted. Input current gradually falls as temperature rises. You should use the value when thermal equilibrium is reached.

The range of usable currents can also be found from the graph below.

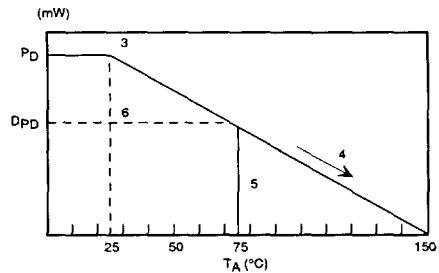

Procedure:

- 1) Find  $P_D$
- 2)  $P_{D1}$  is taken to be  $P_D \times$  (Note: It is not necessary to connect a ceramic capacitor in parallel with an aluminum or tantalum output capacitor. (~0.8 - 0.9))

## DEFINITIONS AND TERMS (CONT.)

- 3) Plot  $P_{D1}$  against 25 °C
- 4) Connect  $P_{D1}$  to the point corresponding to the 150 °C with a straight line.
- 5) In design, take a vertical line from the maximum operating temperature (e.g., 75 °C) to the derating curve.
- 6) Read off the value of  $P_D$  against the point at which the vertical line intersects the derating curve. This is taken as the maximum power dissipation,  $D_{PD}$ .

The maximum operating current is:

$$I_{OUT} = (D_{PD} / (V_{IN(MAX)} - V_{OUT}))$$

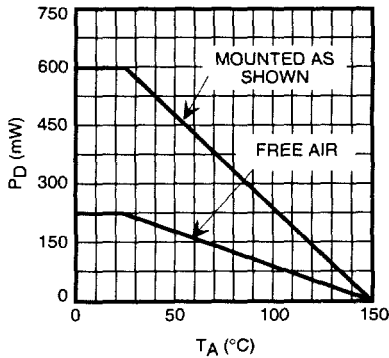

SOT23L-8 POWER DISSIPATION CURVE

## APPLICATION INFORMATION

## INPUT-OUTPUT CAPACITORS

The output capacitor is necessary for stable operation. The regulator may oscillate if the output capacitor is too small or missing. The output capacitor size is determined by load, transient response and external transistor used. Evaluation in the circuit is recommended to ensure performance requirements are satisfied. A minimum of 4.7  $\mu$ F is necessary for stability, with twice that value recommended. The minimum recommended input capacitor is 1  $\mu$ F. Problems do not occur with larger values of capacitance. However, extremely low ESR may result in unstable operation. Thus, the use of large value ceramic capacitors is not recommended on the output.

## BOARD LAYOUT

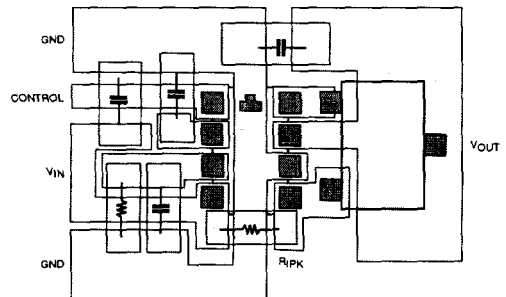

SOT23L-8 BOARD LAYOUT

APPLICATION INFORMATION (CONT.)

PULSE CURRENT LIMIT MODE

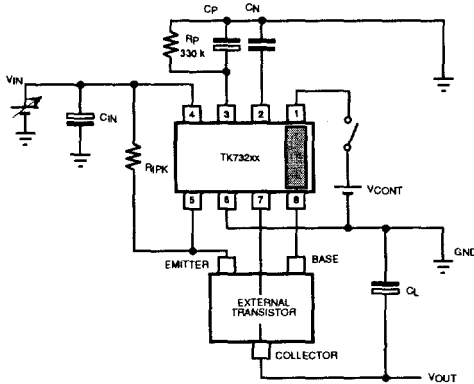

The equation for the pulse output current limit is as follows:

$$I_{SET} \text{ (mA)} = 90 \text{ (mV)} / R_{IPK} \text{ (\Omega)}$$

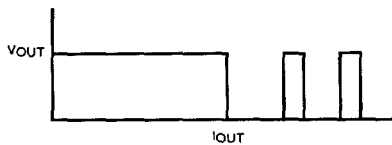

During the initial turn-on, charge (surge) current flows to the output capacitor. This IC has a possibility for the current limit to operate and to turn off the output by the charge current of the output capacitor. Therefore, the relationship between  $C_L$  and  $C_P$  is set as shown in the graph below:

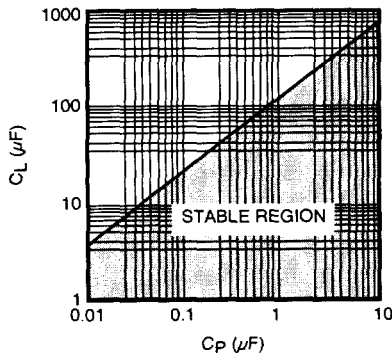

CONTINUOUS CURRENT LIMIT MODE

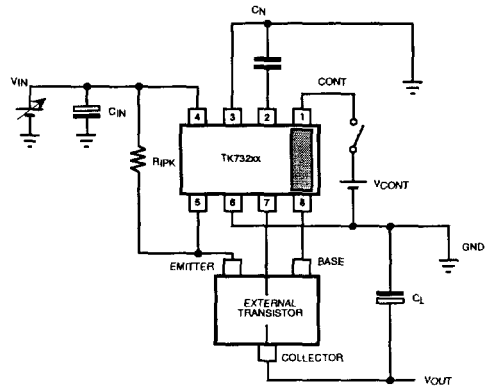

In the continuous current limit mode, the  $C_{PULSE}$  pin (pin 3) is directly connected to ground. The output current limit is set by  $R_{IPK}$  according to the following equation:

$$I_{SET} \text{ (mA)} = 100 \text{ (mV)} / R_{IPK} \text{ (\Omega)}$$

If the continuous current limit mode is also used for output short circuit protection, the  $I_{SET}$  value is set 50% to 100% more than the maximum operating current. The current transistor is selected from the  $I_{SET}$  value. The output voltage drops when the output current exceeds the  $I_{SET}$  value. However, the output voltage returns to normal once the output current decreases below the  $I_{SET}$  value.

## APPLICATION INFORMATION (CONT.)

### EXTERNAL PNP POWER TRANSISTOR

This IC can use any kind of external transistor. The external transistor selection is a function of the load current,  $H_{fe}$  and power dissipation. See following chart:

LOAD CURRENT	RECOMMENDED EXTERNAL TRANSISTOR	RECOMMENDED $R_{IPK}$ ( $\Omega$ )
0 ~ 180 mA	2SB624, 2SB1115, 2SB799 (NEC), 2SB970 (Matsushita)	0.33 ~ 0.39
0 ~ 300 mA	2SB1115, 2SB799 (NEC)	0.22 ~ 0.27
0 ~ 500 mA	2SB1114, 2SB1115 (NEC), 2SB1302 (Sanyo), 2SA1203, 2SA1213, 2SA1734 (Toshiba)	0.12 ~ 0.15
0 ~ 1 A	2SA1242, 2SA1736 (Toshiba), 2SB1302, 2SA1896 (Sanyo)	0.056 ~ 0.068
0 ~ 2 A	2SA1451, 2SA1242 (Toshiba)	0.033 ~ 0.039
0 ~ 3 A	2SA1451 (Toshiba), 2SA1645 (NEC)	0.022 ~ 0.027
0 ~ 4 A	2SA1451 (Toshiba), 2SB904 (Sanyo), 2SA1645 (NEC)	0.012 ~ 0.015

### HIGH-SIDE SWITCHING

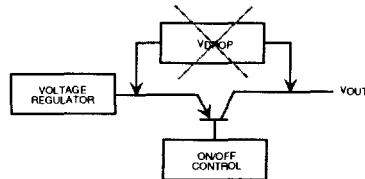

High-side switching should not be implemented by an external transistor as shown above. This results in additional voltage drop and loss of accuracy.

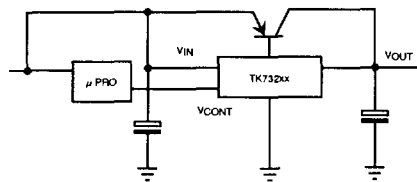

The high output voltage accuracy and low dropout voltage are maintained when the IC is turned ON/OFF by using the control pin as illustrated above.

APPLICATION INFORMATION (CONT.)

VOLTAGE BACKUP OPERATION (HOLDUP TIME)

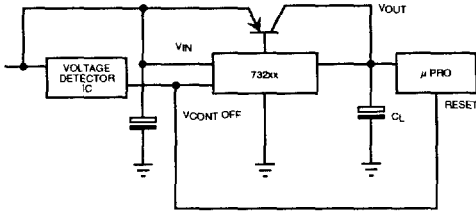

$C_L$  becomes the backup power supply when the microprocessor is reset with the voltage detector IC simultaneously with turning OFF the TK732xx.  $C_L$  provides the holdup time necessary to do an orderly shutdown of the microprocessor.

PARALLEL ON/OFF CONTROL OPERATION

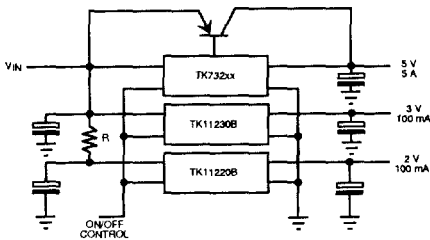

The figure above illustrates multiple regulators being controlled by a single ON/OFF control signal. The series resistor R is put in the input line of the low output voltage regulator in order to prevent overdissipation. The voltage dropped across the resistor reduces the large input-to-output voltage across the regulator, reducing the power dissipation in the device.

OUTPUT VOLTAGE ADJUST

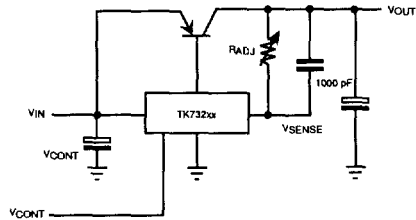

When a highly accurate output voltage is necessary, the output can be adjusted. As shown above, higher output resolution can be achieved by putting a resistor ( $R_{ADJ}$ ) in the  $V_{SENSE}$  pin in parallel with a 1000 pF capacitor. A value of 2 K provides an adjustment of 50 mV typically. Note: using this technique, the output voltage can only be adjusted higher.

BATTERY CHARGER

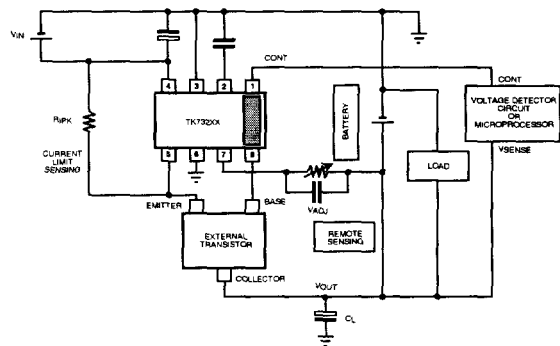

Continuous Current Limit Mode:

$$I_{SET} \text{ (mA)} = 100 \text{ (mV)} / R_{IPK} \text{ (}\Omega\text{)}$$

## APPLICATION INFORMATION (CONT.)

$I_{SET}$  (Continuous Current Limit Mode) is set to the desired charging current.

circuit condition,  $T_{r1}$  is turned "off." This converts the circuit into the pulse current limit mode of operation, reducing the power dissipation in the pass transistor. The transition between the continuous and pulse current limit modes can be controlled by adjusting the operating point of  $T_{r1}$  by the value of resistor R.

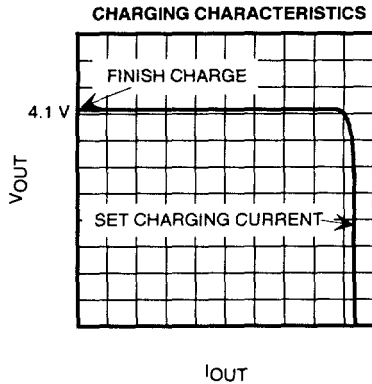

**LITHIUM ION BATTERY CHARGER WITH  
OVERDISSIPATION PROTECTION OF EXTERNAL  
TRANSISTOR (SHORT CIRCUIT MODE)**  
(RECOMMENDED WITH TK732xxMCLH)

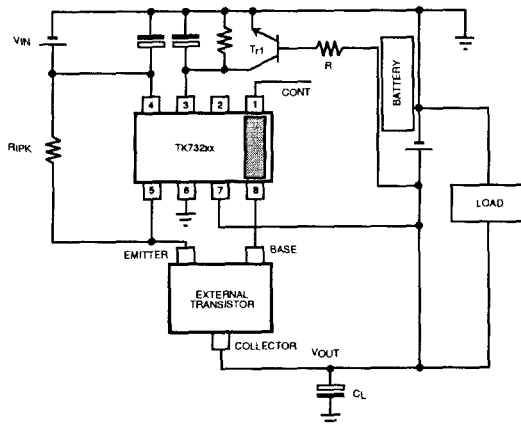

During normal operation,  $T_{r1}$  is turned ON, connecting pin 3 ( $C_{PULSE}$ ) to ground. This provides the continuous current limit mode for normal operating conditions. During a short