

SB-36220IX

# DIGITAL-TO-SYNCHRO/RESOLVER PCI BUS SIX CHANNEL CONVERTER CARD

Make sure the next  
Card you purchase  
has...

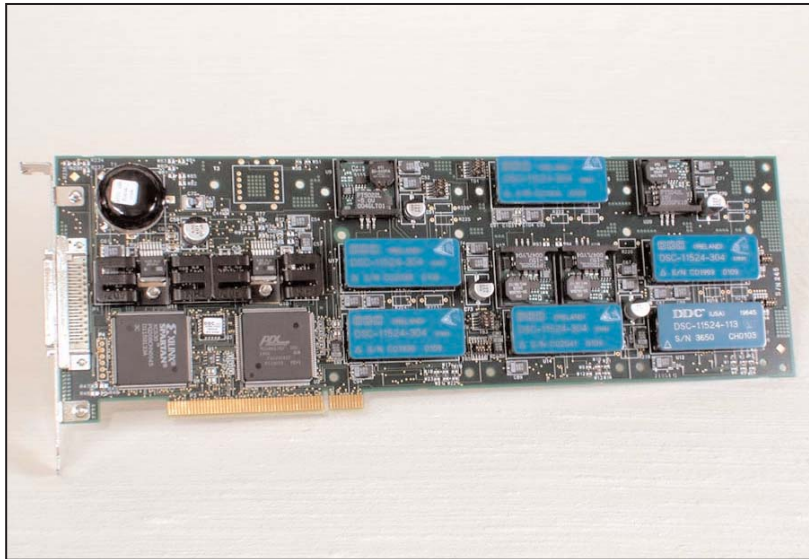

## FEATURES

- Up to Six Channels
- Output Amplitudes:  
2 & 6.8 Vrms L-L Resolver,  
11.8 Vrms L-L Resolver, or Synchro,  
90 Vrms L-L Synchro 60/400 Hz
- Output Voltages can be Scaled Lower
- Transformer Isolation Available
- On-Board Programmable Oscillator  
Option with 1.5VA Drive
- Programmable Dynamic Rotation
- Programmable Two-Speed
- DLL's and Libraries for Windows®  
9x/2000/XP, Windows NT®, Linux,  
and LabVIEW™, (*dataSIMS* Support)
- 0° to +70°C Standard Operating  
Temperature
- Two-Speed Simulation

## DESCRIPTION

The SB-36220IX is a PCI bus card that contains up to six channels of fully independent Digital-to-Synchro (D/S) or Digital-to-Resolver (D/R) converters. For each channel the conversion process is implemented using a DDC D/S or D/R converter. Optional output Scott-T transformers are available for the DSC-11524 D/S converter series. An optional on-board reference that can be configured for 2, 26 or 115 volts eliminates the need for an external oscillator. The SB-36220IX can also be used to simulate dynamic rotation in both single speed and two-speed systems.

The SB-36220IX comes with "C" libraries along with an easy to use Windows Graphical User Interface (GUI) to allow this card to be used in a wide range of applications. Linux software is also available.

## APPLICATIONS

The SB-36220IX is designed for modern, high performance industrial and military control systems. Synchros and resolvers are used in applications where position feedback information is required. Providing accurate position information to simulate synchro/resolver outputs is essential to evaluate overall system performance. The SB-36220IX is ideal for test stands and simulators. It can be used as an upgrade from the DSC-36020 or DSC-36022 ISA cards.

FOR MORE INFORMATION CONTACT:

Technical Support:  
1-800-DDC-5757 ext. 7771



Data Device Corporation  
105 Wilbur Place  
Bohemia, New York 11716  
631-567-5600 Fax: 631-567-7358  
[www.ddc-web.com](http://www.ddc-web.com)

All trademarks are the property of their respective owners.  
© 2000 Data Device Corporation

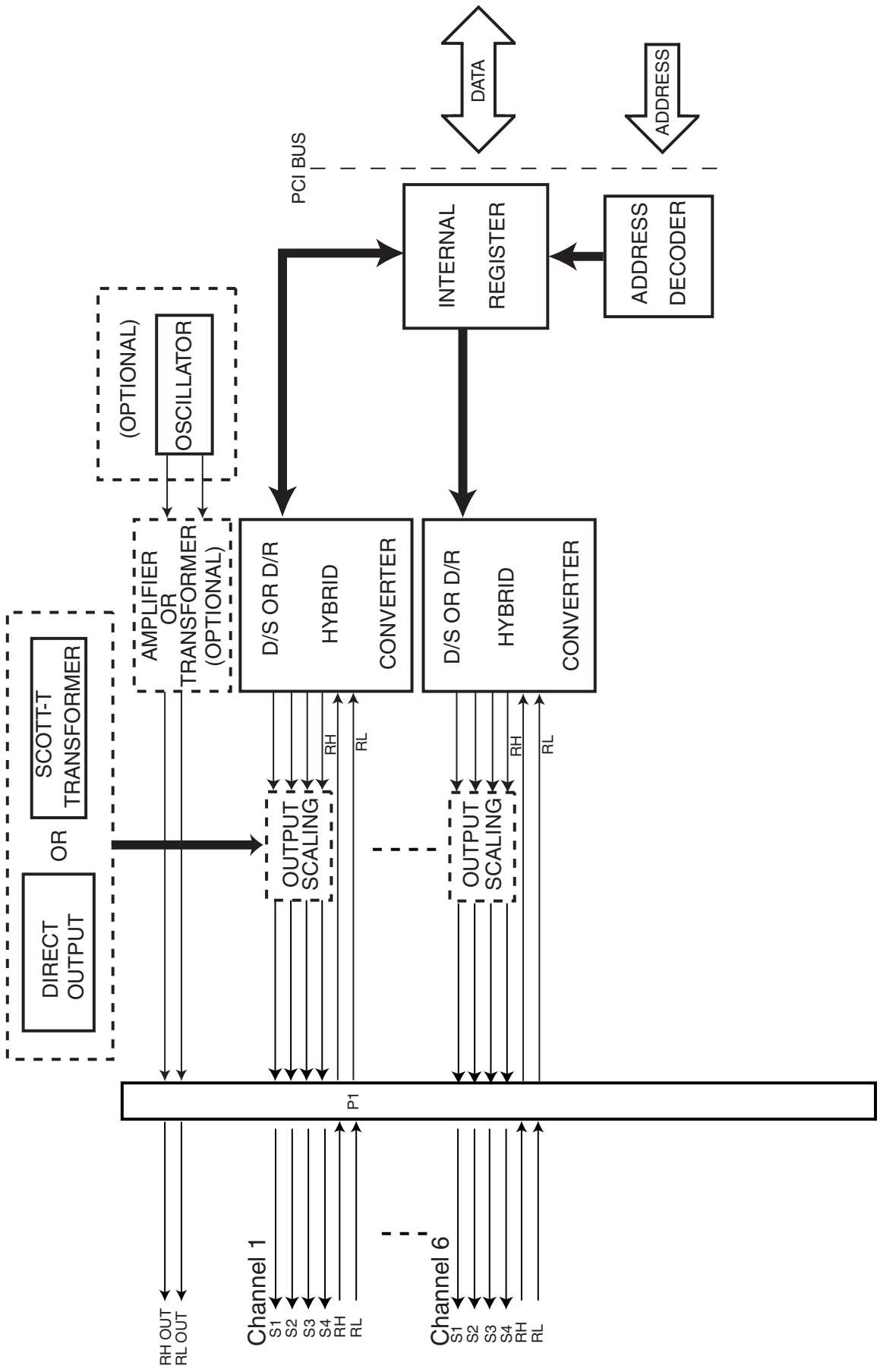

FIGURE 1. SB-36220IX BLOCK DIAGRAM

**TABLE 1. SB-36220IX SPECIFICATIONS (PER CHAN)**

These specifications apply over the rated power supply, temperature, and reference frequency ranges; 10% signal amplitude variation and 10% harmonic distortion.

PARAMETER	UNIT	VALUE			
<b>RESOLUTION</b>	Bits	12 or 16 programmable			
<b>ACCURACY</b> DSC-11520-305 DR-11525-305 DSC-11524-304	47-1KHZ 1 Min. 1 Min. 2 Min.	For frequency higher than 1kHz, use the DR-11525 and refer to the converter data sheet specs.			
<b>ON BOARD OSCILLATOR</b>  Option P/N Carrier Frequency Voltage Range Drive		<b>Solid State</b>	<b>Transformer Isolated</b>		
		I4	I5	I6	
	Hz	57 - 7k	360 - 7k	57 - 440	
	Vrms mA max.	0 - 3.4 300	0 - 26 60	0 - 115 13	
<b>SIGNAL OUTPUT</b>  Synchro Resolver Resolver (Single Ended)		<b>Solid State</b>	<b>Transformer Isolated</b>		
	Vrms L-L	11.8	11.8	90	
	Vrms L-L Vrms L-L	11.8 2.0 or 6.8 (See Note 1)	11.8	—	
<b>REFERENCE INPUT</b>  Option P/N Carrier Frequency Type (differential) Voltage (±5%) Input Impedance • differential (min) • single ended (min) Common-mode Range		<b>Solid State</b>	<b>Transformer Isolated</b>		
		I0	I1	I2	I3
	Hz	47 - 7k diff.	400 diff.	360 - 400 diff.	60 diff.
	Vrms	4.4, 26, 115	26	115	115
	Ohms	100k	100k	300k	300k
	Ohms Vpeak	50k 50	50k 50	200k 200	200k 200
<b>DYNAMIC ROTATION</b>	RPS MIN/MAX	at 12 bit resolution (0.03 to 2014) at 16 bit resolution (0.03 to 125)			
<b>POWER SUPPLY (NOTE 2)</b> Voltage Current Fully loaded (1.5VA OSC option + 6 Hybrids DSC-11520/24, DR-11525) 6 Hybrids only (DSC-11520/24, DR-11525)	Vdc	+5			
	A max.	4			
	A max.	2			
<b>TEMPERATURE RANGE</b> Operating (XIX-3XXX) Storage	°C	0 to +70			
	°C	-40 to +85			
<b>PHYSICAL CHARACTERISTICS</b> Size  Weight		Full-size PCI format. Double-width card when 90 Vrms/115 Vrms required.			
	in.	12.3 x 4.2 x 0.91			
	mm. lbs.	312 x 106.7 x 23.1 1 max, depending on configuration			
<b>Note 1:</b> S1 and S4 are no connect, because outputs are single ended (common gnd to common gnd on card).					
<b>Note 2:</b> Requires a 5V PCI card slot, will not operate on a 3.3V PCI slot.					
<b>Note 3:</b> For specific specifications not listed, refer to the specific hybrid type data sheet. See ordering info to determine hybrid type used.					

**SB-3622X SOFTWARE DISPLAY WINDOWS**

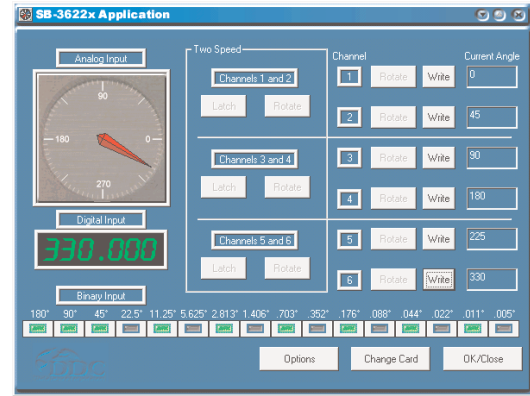

**FIGURE 2. CONTROL PANEL**

Easy to use control panel allows position data entry for each channel. This is ideal for test environments.

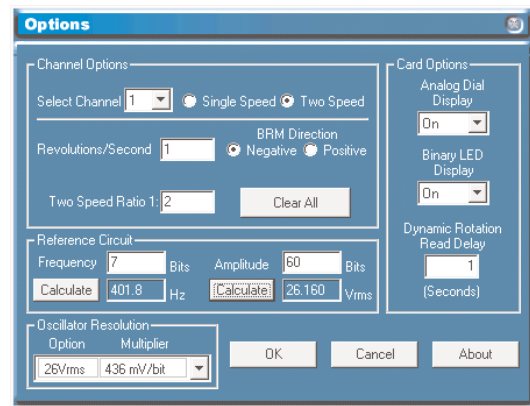

**FIGURE 3. OPTIONS PANEL**

The options panel allows the oscillator to be set for amplitude and frequency, dynamic rotation and two-speed mode of operation.

**SOFTWARE**

Window GUI example software and DOS console application example software are included. The provided DDL allows the user to create custom application software. The software DDL provides function calls to control resolution, bandwidth, reference amplitude and reference frequency. This provides access to angular information and can drive dynamic rotation of the output.

dataSIMS software support available, contact DDC software applications department for details.

**HARDWARE CONFIGURATION**

The SB-3622X is a PCI device, and as such does not require any jumpers or switches to set the Base address or interrupt values. The job of configuration for Plug-and-Play PCI configuration is performed by the PC BIOS. During the initial power on boot process, the BIOS performs an enumeration of the PCI bus and

locates a configuration in the system that satisfies the card requirements. The card communicates with the BIOS to determine how much memory it requires, along with any other operating parameters that the system needs to know by way of configuration registers built into the card.

These registers are configured at the factory to contain the optimum values for the operation of the SB-3622X. There is no need for the user to provide a specific memory location or size, or have to manipulate interrupts to get the Digital-to-Synchro/Resolver (D-S/R) card installed. The SB-3622X PCI card and software drivers allow for shared interrupts, thus simplifying the installation and reducing the risk of device conflicts.

### SIGNAL INPUT / OUTPUT CONFIGURATION

Input and output options are created by factory installation of jumpers (TB1 to TB6) on each of the available channels. TABLE 2 lists the Jumper Block designations for each channel. TABLE 3 lists the “D” connector reference input pins for each channel. TABLE 4 lists the jumper installation for each input option. TABLE 5 lists the jumper installation for each output option. FIGURE 4 shows the jumper location and configuration for jumper blocks TB1 to TB6.

Pins 1 through 6 of each TB jumper block (TB1-TB6) determine the card’s output configuration. Pins 7 through 10 determine the card’s input configuration.

**NOTE:** The output signal configuration of the hybrids will match the output type option selected for types 5 through 8 (see ordering information) which require a daughter board.

### INPUT CONFIGURATION

TBx Jumpers are configured as per Table 4 to select the appropriate input option based upon the card’s Reference option (see ordering information).

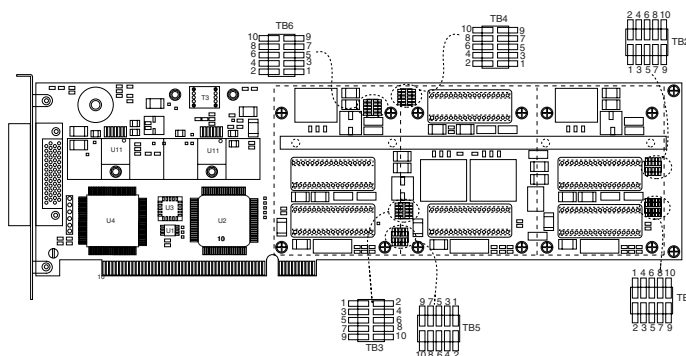

FIGURE 4. SB-3622X JUMPER LOCATION

TABLE 2. TBx JUMPER BLOCK DESIGNATIONS	
JUMPER BLOCK	CHANNEL
TB1	1
TB2	2
TB3	3
TB4	4
TB5	5
TB6	6

TABLE 3. “D” CONNECTOR CHANNEL REFERENCE INPUT ASSIGNMENTS				
CHANNEL	REFERENCE HIGH		REFERENCE LOW	
	PIN #	FUNCTION	PIN #	FUNCTION
1	17	RH_EXT_CH1	19	RL_EXT_CH1
2	24	RH_EXT_CH2	7	RL_EXT_CH2
3	6	RH_EXT_CH3	22	RL_EXT_CH3
4	13	RH_EXT_CH4	9	RL_EXT_CH4
5	8	RH_EXT_CH5	15	RL_EXT_CH5
6	14	RH_EXT_CH6	5	RL_EXT_CH6

**TABLE 4A. USING THE SOLID STATE REFERENCE INPUT (OPTION 0)**

REF VOLT	TBX JUMPERS 7-8, 9-10
4.4V	DON'T CARE
26V	IN
115V	OUT (NOTE 1)

CONNECT THE REFERENCE VOLTAGE TO EACH ACTIVE CHANNELS REF INPUT, RH\_ext & RL\_ext ON THE "D" CONNECTOR.

"D" CONNECTOR

NOTE 1: FACTORY CONFIGURED FOR 115V CONFIGURATION, NO JUMPERS IN 7-8, 9-10.

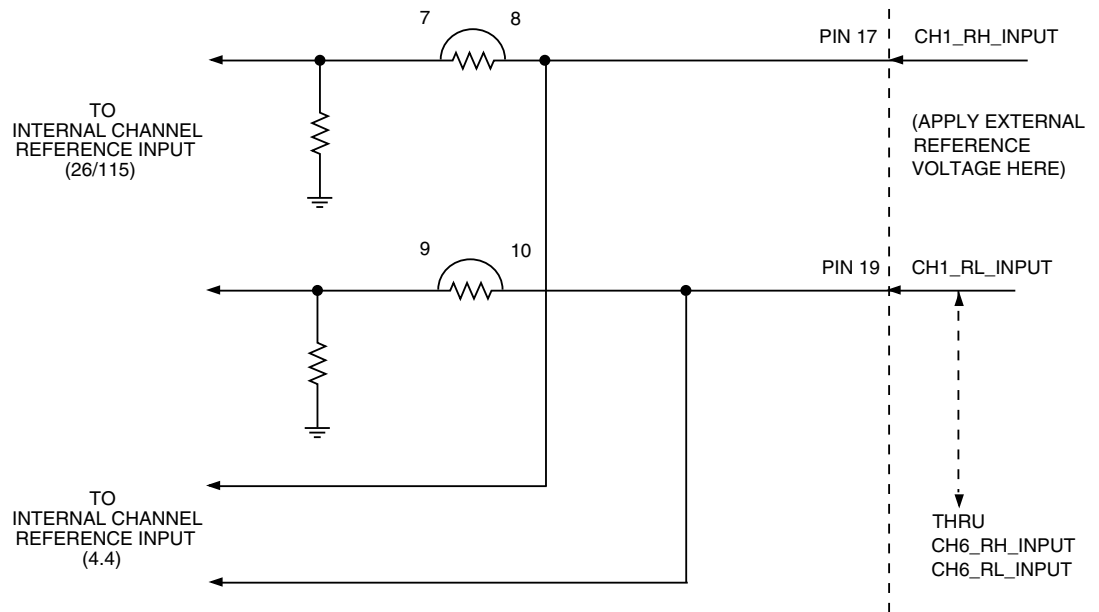

**CAUTION:** INCORRECT CONFIGURATION CAN DAMAGE CARD.

**TABLE 4B. USING THE TRANSFORMER ISOLATED EXTERNAL REFERENCE INPUTS (OPTIONS 1, 2, 3)**

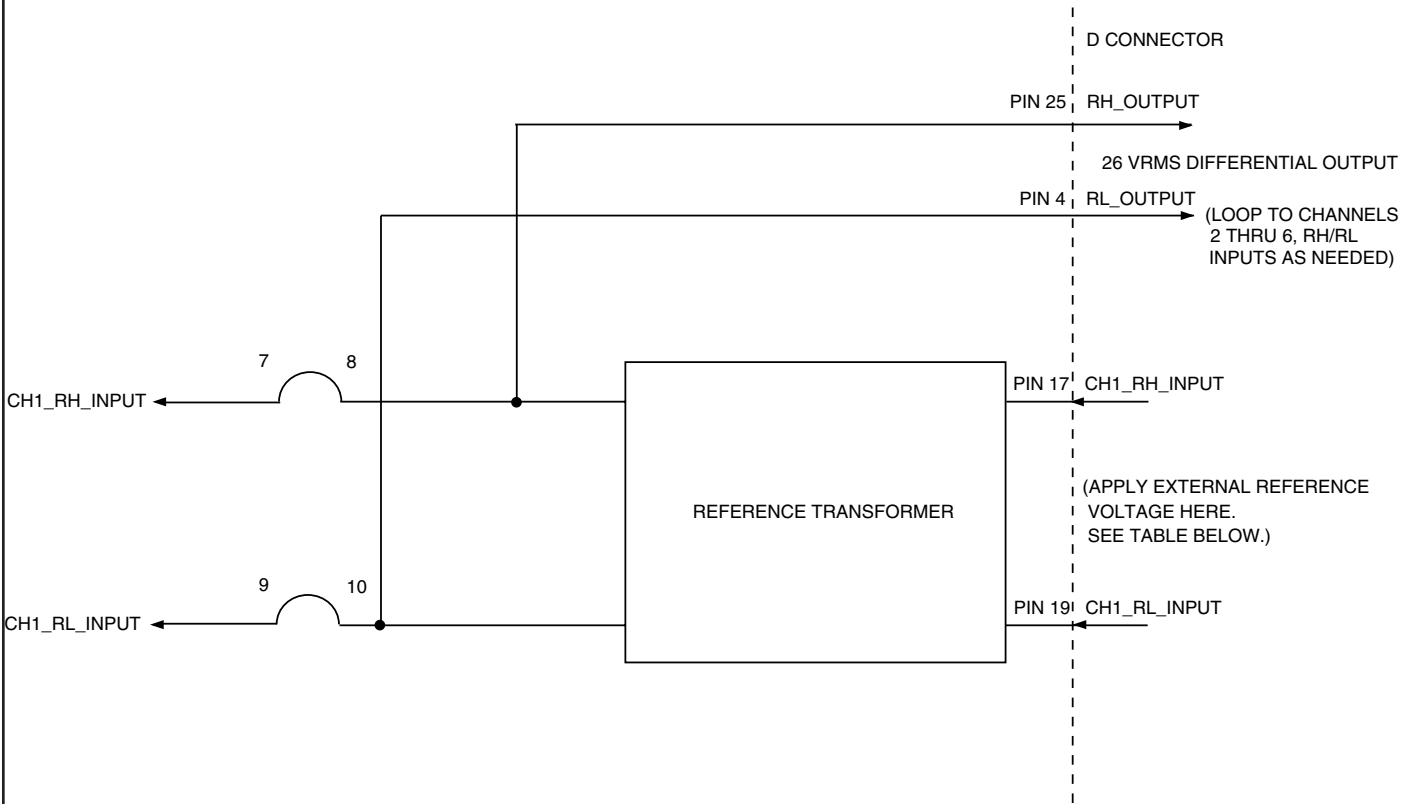

**CAUTION:** INCORRECT CONFIGURATION CAN DAMAGE CARD.

"D" CONNECTOR	
<p>CONNECT THE REFERENCE VOLTAGE TO CHANNEL 1 ON THE "D" CONNECTOR (RH PIN 17 AND RL PIN 19) ONLY. THIS WILL CONVERT THE VOLTAGE CONNECTED INTO CHANNEL 1 TO 26VRMS AND OUTPUT THIS VOLTAGE ON THE D CONNECTOR ON RH_26_INT (PIN 25) AND RL_INT (PIN 4). ALSO, THIS VOLTAGE IS INPUT INTO THE CHANNEL 1 REFERENCE INPUT SO THAT CHANNEL 1 IS NOW READY FOR USE.</p> <p>CONFIGURING ADDITIONAL CHANNELS: IN ORDER TO USE THE SAME REFERENCE OR EXCITATION VOLTAGE USED FOR CHANNEL 1 FOR ADDITIONAL CHANNELS, LOOP THE 26 VRMS OUTPUT ON THE D CONNECTOR FROM RH_26_INT (PIN 25) AND RL_INT (PIN 4) TO THE REFERENCE HIGH AND LOW PINS OF CHANNELS 2 TO 6 (SEE TABLE 3).</p>	
REF INPUT TYPE OPTION #	VOLTAGE/FREQ
1	26V 400HZ
2	115V 400HZ
3	115V 60HZ

**TABLE 4C. USING THE OPTIONAL ON BOARD REFERENCE OSCILLATOR (INTERNAL OPTIONS 4, 5, 6)**

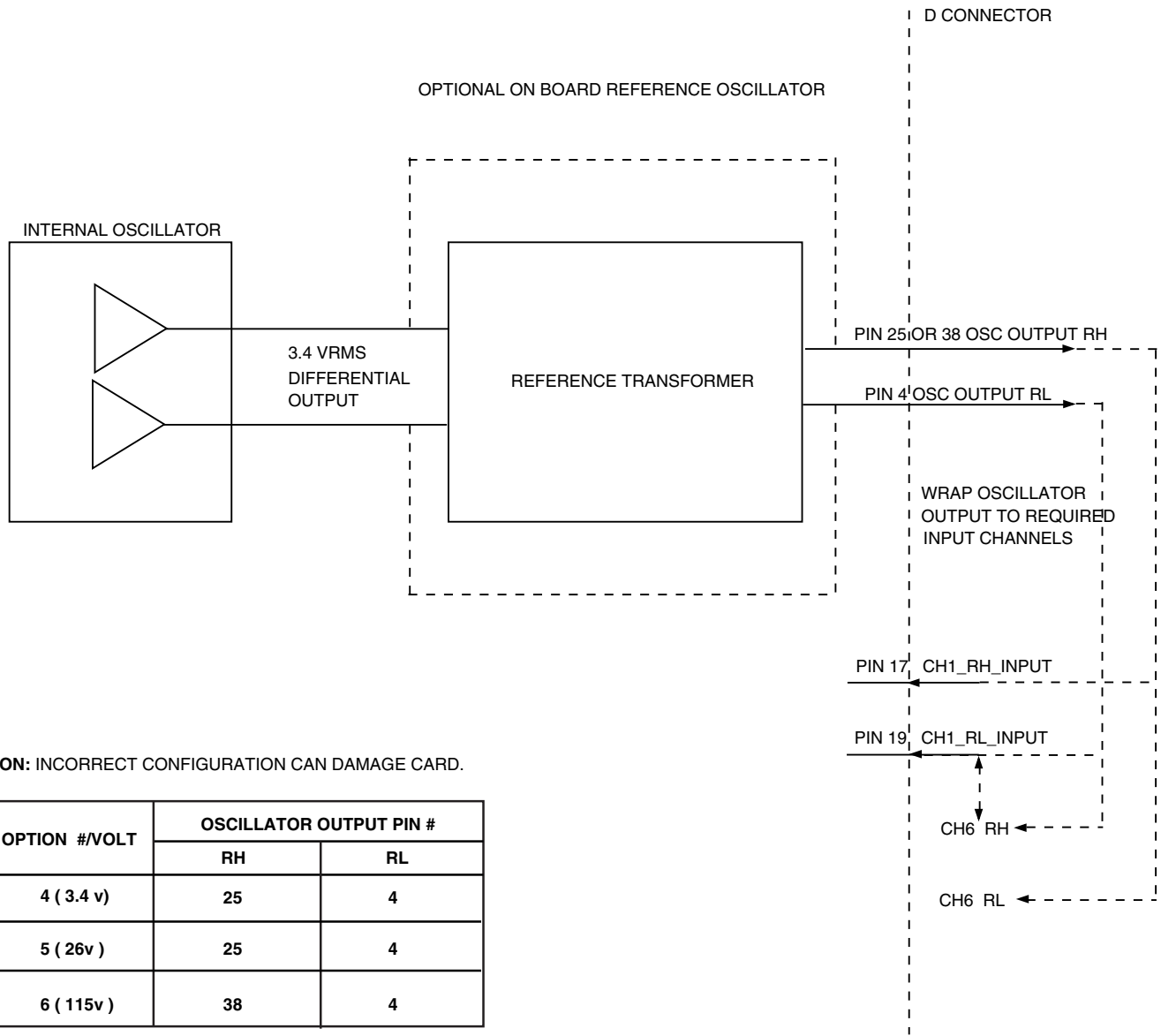

**CAUTION:** INCORRECT CONFIGURATION CAN DAMAGE CARD.

REF OPTION #/VOLT	OSCILLATOR OUTPUT PIN #	
	RH	RL
4 ( 3.4 v )	25	4
5 ( 26v )	25	4
6 ( 115v )	38	4

## OUTPUT CONFIGURATION

TBx Jumpers are configured as per Table 5 to select an appropriate output option.

TABLE 5. OUTPUT TBx JUMPER CONFIGURATION (APPLIES TO TB1-6) JUMPERS INSTALLED				
OUTPUT OPTION #	TYPE	HYBRID TYPE		
		3	5	8
1	11.8v Synchro	3-4, 5-6, 7-8, 9-10	3-4, 5-6, 7-8, 9-10	N/A
2	11.8v Resolver	N/A	1-2, 5-6, 7-8, 9-10	7-8, 9-10
3	6.8v Resolver	N/A	1-2, 7-8, 9-10	N/A
4	2v Resolver	N/A	N/A	N/A
5 (Note 3)	11.8v Synchro	N/A	3-4, 5-6, 7-8, 9-10	N/A
6 (Note 3)	11.8v Resolver	N/A	1-2, 5-6, 7-8, 9-10	N/A
7 (Note 3)	90v Synchro	N/A	3-4, 5-6, 7-8, 9-10	N/A
8 (Note 3)	90v Synchro	N/A	3-4, 5-6, 7-8, 9-10	N/A

### Notes:

1. N/A = No jumpers installed.
2. 90v output requires a transformer(Refer to ordering information).
3. Transformer coupled output configurations cannot be field reconfigured (Output types 5, 6, 7, and 8).
4. For reference type 0 & 6 when applying a 115v ref input remove jumpers 7-8 and 9-10.

## CARD PINOUTS

This section describes the pinouts for the card. The card has one connector, a 50-pin mini D connector. The pinouts for this mating connector are shown below.

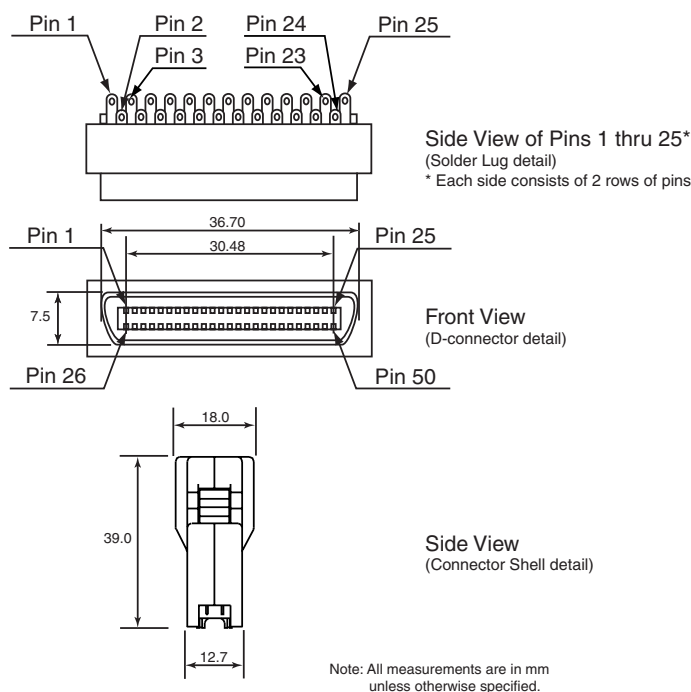

**FIGURE 5. 50 PIN D-TYPE MATING CONNECTOR**

PN: 50 pin connector Solder Plug (3M 10150-3000VE)  
50 pin connector Junction Shell (3M 10350-52FO-008)

TABLE 6. SB-36220IX PINOUTS			
PIN	NAME	PIN	NAME
1	-5V EXT */OUTPUT	26	S1_CH 6/OUTPUT
2	+15V EXT */OUTPUT	27	S3_CH 5/OUTPUT
3	GND	28	S1_CH 5/OUTPUT
4	RL_INT/OUTPUT	29	S3_CH 6/OUTPUT
5	RL_EXT_CH 6/INPUT	30	S2_CH 6/OUTPUT
6	RH_EXT_CH 3/INPUT	31	S4_CH 6/OUTPUT
7	RL_EXT_CH 2/INPUT	32	S2_CH 5/OUTPUT
8	RH_EXT_CH 5/INPUT	33	S4_CH 5/OUTPUT
9	RL_EXT_CH 4/INPUT	34	S3_CH 4/OUTPUT
10	GND 1	35	S1_CH 4/OUTPUT
11	+5 EXT */OUTPUT	36	S3_CH 3/OUTPUT
12	-15 EXT */OUTPUT	37	S4_CH 4/OUTPUT
13	RH_EXT_CH 4/INPUT	38	RH_115_INT/ OUTPUT
14	RH_EXT_CH 6/INPUT	39	S1_CH 3/OUTPUT
15	RL_EXT_CH 5/INPUT	40	S4_CH 3/OUTPUT
16	GND 5	41	S2_CH 4/OUTPUT
17	RH_EXT_CH 1/INPUT	42	S2_CH 3/OUTPUT
18	GND 2	43	S1_CH 2/OUTPUT
19	RL_EXT_CH 1/INPUT	44	S1_CH 1/OUTPUT
20	GND 6	45	S3_CH 2/OUTPUT
21	GND 4	46	S2_CH 2/OUTPUT
22	RL_EXT_CH 3/INPUT	47	S4_CH 2/OUTPUT
23	GND 3	48	S2_CH 1/OUTPUT
24	RH_EXT_CH 2/INPUT	49	S3_CH 1/OUTPUT
25	RH_26_INT/OUTPUT	50	S4_CH 1/OUTPUT

\*No connection required, these are test points for internal power supplies.



**TABLE 7. REFERENCE VOLTAGE SETTINGS REQUIRED TO OBTAIN SPECIFIED OUTPUT VOLTAGES**

OUTPUT OPTION	OUTPUT TYPE	REFERENCE INPUT REQUIRED (VRMS)	MULTIPLIER X = 0
1	11.8V L-L Synchro	26	0.45
2	11.8V L-L Resolver	26	0.45
3	6.8V Resolver (Single Ended)	26	0.26
4	2V Resolver (Single Ended)	4.4	0.455
5	11.8V L-L Synchro/400Hz, Transformer Coupled	26	0.45
6	11.8V L-L Resolver/400Hz, Transformer Coupled	26	0.45
7	90V L-L Synchro/400Hz, Transformer Coupled	115	0.78

**SIGNAL CONNECTIONS**

**•Synchro Mode Connect S1, S2, S3**

- S1 = X
- S2 = Z
- S3 = Y

**•Resolver Mode Connect**

- S3 = +SIN
- S1 = -SIN
- S2 = +COS
- S4 = -COS

**•Single Ended Mode Connections**

When using 2v single ended configurations, S1 and S4 on card connector are no connect. Use associated analog ground per output channel for S1 and S4 resolver outputs used.

**SCALING LOWER OUTPUT VOLTAGES**

All output voltages can be scaled down by lowering the required reference input voltage as follows:

$$\text{Reference Input Voltage} = \frac{\text{Desired Output Voltage}}{X}$$

(Where X is the output option ratio multiplier - refer to Table 7).

Example: For a Custom Output Voltage, using an 11.8v synchro option 1 card.  
(Note that desired output voltage is lower than the card selection output voltage)

Desired Output Voltage = 9V  
Multiplier X = .45 (for option #1)

$$\text{Reference Input Voltage} = \frac{9 \text{ V}}{.45}$$

Reference Input Voltage = 20 V

**REFERENCE OPTIONS**

Table 8 details the card's reference isolation type.

**TABLE 8. REFERENCE ISOLATION TYPE**

REFERENCE OPTION	REFERENCE TYPE	T1	T2	T3	T5
0	External, Solid State Input				
1	External, 26V/400Hz Transformer Isolated Input			X	
2	External, 115V/400Hz Transformer Isolated Input			X	
3	External, 115V/60Hz Transformer Isolated Input		X		
4	Internal, 3.4V High Current (300ma, Differential) Solid State Oscillator Output				
5	Internal, 26V High Current (1.5VA) Transformer Isolated Oscillator Output	X			
6	Internal, 115V High Current (1.5VA) Transformer Isolated Oscillator Output				X

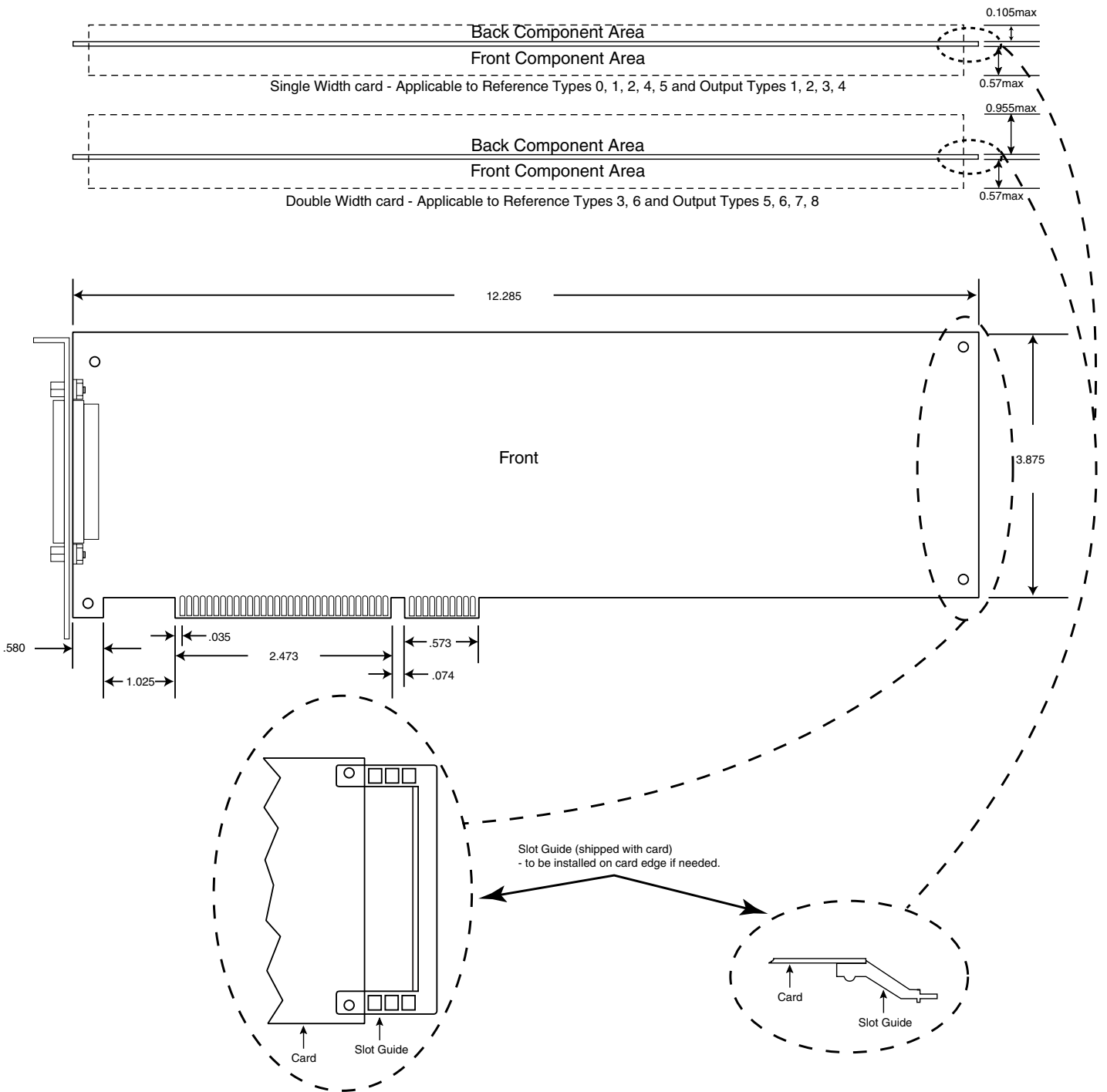

**FIGURE 6. SB-36220IX MECHANICAL OUTLINE**

## ORDERING INFORMATION

SB-3622 X I X - X X X X

### Supplemental Process Required

Blank = None  
N = Conformal Coat (NOTE 7)

### Hybrid Type and Accuracy (NOTE 1)

3 = DSC-11520-305 (1 minute)  
5 = DSC-11524-304 (2 minutes)  
8 = DR-11525DX-305 (1 minute)

### Number of Channels:

1 = One channel  
2 = Two channels  
3 = Three channels  
4 = Four channels  
5 = Five channels  
6 = Six channels

### Temperature Range:

3 = 0°C to +70°C

### Reference Input Type/Oscillator Output:

0 = External, solid state non-isolated (4.4 Vrms, 26 Vrms or 115 Vrms) (**NO** on board oscillator)  
1 = External, 26 Vrms/400Hz transformer isolated (**NO** on board oscillator)  
2 = External, 115 Vrms/400Hz transformer isolated (**NO** on board oscillator)  
3 = External, 115 Vrms/60Hz transformer isolated (**NO** on board oscillator)  
4 = Internal, 3.4 Vrms Differential (300 mA max) (Notes 6, 8)  
5 = Internal, 1.5 VA Drive, 26 Vrms Transformer Isolation (60 mA max) (Note 8)  
6 = Internal, 1.5 VA Drive, 115 Vrms Transformer Isolation (13 mA max) (Notes 4, 8)

Output Type (Note 1)	For Programmable Internal Oscillator Selections, Reference Voltage Required to Obtain the Listed Output is :	Reference Input Type/Oscillator Output Selections	1 Min Accuracy	2 Min Accuracy
			Hybrid Type/ Drive	Hybrid Type/ Drive
1 = 11.8 Vrms L-L Synchro	26V	0,1,2,3,5,6	3/2 MA	5/15 MA
2 = 11.8 Vrms L-L Resolver	26V	0,1,2,3,5,6	8/2 MA	5/15 MA
3 = 6.8 Vrms Resolver (NOTE 5)	26V	0,1,2,3,5,6	8/2 MA	5/15 MA
4 = 2 Vrms Single Ended Resolver (NOTES 2 and 5, 9)	4.4V	0,1,2,3,4,5,6 (note 6)	8/2 MA	—
5 = 11.8 Vrms L-L Synchro/400Hz, Transformer coupled (NOTE 3)	26V	0,1,2,5,6	—	5/14 MA
6 = 11.8 Vrms L-L Resolver/400Hz, Transformer coupled (NOTE 3)	26V	0,1,2,5,6	—	5/14 MA
7 = 90 Vrms L-L Synchro/400Hz, Transformer coupled (NOTE 3)	115V	0,1,2,5,6	—	5/1.9 MA
8 = 90 Vrms L-L Synchro/60Hz, Transformer coupled (NOTE 3)	115V	0,3,6	—	5/1.9 MA

### Notes:

- All channels are configured for the same converter type and output types. For non-standard configurations please contact factory.
- 2 Volt Resolver output requires the DR-11525 converter, with a 4.4Vrms reference voltage input.
- Transformer isolated output requires the DSC-11524 converter. (Add 1.5 minutes to specified accuracy with transformer coupled option.), option output type 8, 90V 60Hz adds 2.5 minutes to specified accuracy.
- Reference type 6 (Internal, 115V high current) requires 2 slots.
- Outputs are single ended, S1 and S4 are no connect, use card appropriate channel common ground.
- Oscillator Option #4 (3.4 Vrms) is a low cost option when output voltages of 1.5 Vrms or less are needed to be scaled with output type 4.
- For conformal coated boards all components will be soldered down, no sockets.
- Oscillator Output is programmable to MAX voltage of option selection range. Frequency range is programmable per spec table 1.
- For differential mode configuration, use S1, S2, S3, S4 and note that output voltage will be approx 4Vrms and can be scaled down via ref input voltage. Do not connect either differential pair to ground.

### Included Accessories:

- MN-3622XXX-001 Hardware and Software Manual
- Windows GUI, DLL's and libraries software provided (CD format)
- 1 mating connector, 50 pin, D-type
- PCI retainer and screws

**Note:** The above products contain tin-lead solder.

### SUGGESTED MATING CONNECTORS:

- Solder Plug: 3M 10150-3000VE
- Junction Shell: 3M 10350-52FO-008

## DISCRETE MODULES / PC BOARD ASSEMBLIES PROCESSING TABLE

STANDARD DDC PROCESSING FOR DISCRETE MODULES/PC BOARD ASSEMBLIES		
TEST	METHOD(S)	CONDITION(S)
INSPECTION / WORKMANSHIP	IPC-A-610	Class 3
ELECTRICAL TEST	DDC ATP	—

The information in this data sheet is believed to be accurate; however, no responsibility is assumed by Data Device Corporation for its use, and no license or rights are granted by implication or otherwise in connection therewith.  
Specifications are subject to change without notice.

Please visit our Web site at [www.ddc-web.com](http://www.ddc-web.com) for the latest information.



105 Wilbur Place, Bohemia, New York, U.S.A. 11716-2482

**For Technical Support - 1-800-DDC-5757 ext. 7771**

**Headquarters, N.Y., U.S.A.** - Tel: (631) 567-5600, Fax: (631) 567-7358  
**Southeast, U.S.A.** - Tel: (703) 450-7900, Fax: (703) 450-6610  
**West Coast, U.S.A.** - Tel: (714) 895-9777, Fax: (714) 895-4988  
**United Kingdom** - Tel: +44-(0)1635-811140, Fax: +44-(0)1635-32264  
**Ireland** - Tel: +353-21-341065, Fax: +353-21-341568  
**France** - Tel: +33-(0)1-41-16-3424, Fax: +33-(0)1-41-16-3425  
**Germany** - Tel: +49-(0)89-150012-11, Fax: +49-(0)89-150012-22  
**Japan** - Tel: +81-(0)3-3814-7688, Fax: +81-(0)3-3814-7689  
**World Wide Web** - <http://www.ddc-web.com>



DATA DEVICE CORPORATION  
REGISTERED TO ISO 9001:2000  
FILE NO. A5976