

4

3

2

FORM NO. OL-MD1-VJMS-SS-001

ADAPTER P/N

MD1-VJMS-SS-001

ECO NO.	LTR	DESCRIPTION	DATE	RELEASED
A		INITIAL RELEASE		

COMPONENT	MATERIAL	FINISH
CONTACT:	BeCu PER ASTM B 196 AND/DR ASTM B 197 AND UNS #C17300 DR UNS #C172000	GOLD PLATE PER ASTM B 488, TYPE 1, GRADE C, .000050 TD, .000100 THICK OVER NICKEL PER AMS QQ-N-290 DR AMS 2404 .000050 TD, .000150 THICK.
INSULATOR(S)	PTFE(TEFLON) PER ASTM D 1710 AND ASTM D 1457	N/A
HOUSINGS, SHIMS, AND STUBS:	CRES 303 PER ASTM A-484 AND ASTM A-582 DR ASTM A-555 DR ASTM A-581.	PASSIVATE PER AMS QQ-P-35.
SHROUD	CRES 303 PER ASTM A-484 AND ASTM A-582 DR ASTM A-555 DR ASTM A-581.	GOLD PLATE PER ASTM B 488, TYPE 1, GRADE C, .000050 TD, .000100 THICK OVER NICKEL PER AMS QQ-N-290 DR AMS 2404 .000050 TD, .000150 THICK.

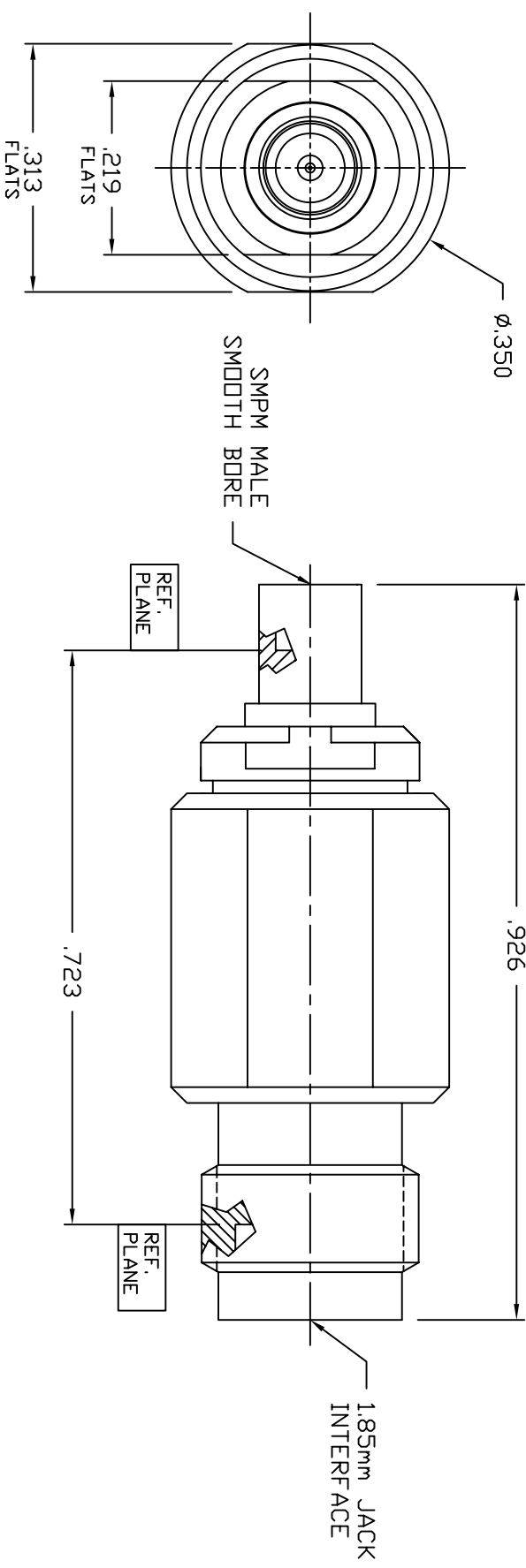

- NOTES:
- OPERATING FREQUENCY: DC-40 GHZ.
  - VSWR: 1.10:1 MAX.

UNLESS OTHERWISE SPECIFIED, DIMENSIONS ARE IN INCHES. TOLERANCES ON:

DECIMALS	ANGULAR	PRODUCT CODE
.XX ±.005	±.1	N/A
.XXX ±.003	±.05	
	±.1/32	

DO NOT SCALE DRAWING

THIS DRAWING AND THE DATA DISCLOSED HEREIN IS CONFIDENTIAL AND PROPRIETARY TO CRISTEK CORPORATION. IT IS TO BE USED, OR DISCLOSED IN WHOLE OR IN PART TO ANYONE WITHOUT THE WRITTEN PERMISSION OF CRISTEK CORPORATION.

DRAWN	DATE	SIZE	CASE NO.	DWG. NO.
CHECK	12/12/03	C 67720	OL-MD1-VJMS-SS-001	
APPROVED	12/12/03	SCALE		
CAD FILENAME:	GSK-1007			

CRISTEK  
1301 S. LEVIA STREET  
MILWAUKEE, WI 53214  
(714) 618-2000

SMPM(M) SMOOTH BORE  
TO 1.85mm JACK  
PRECISION ADAPTER

THIRD ANGLE PROJECTION

SCALE NONE

SHEET 1 OF 1