

NOTES:

- MATERIALS AND FINISHES:  
 BODY: BRASS, GOLD PLATING  
 CONTACT: BERYLLIUM COPPER, GOLD PLATING.  
 INSULATOR: PTFE
- PHYSICAL:  
 A. OPERATING TEMPERATURE: -65°C to +165°C  
 B. DURABILITY: 100 MATING CYCLES MINIMUM  
 C. INTERFACE: PROPRIETARY AFI INTERFACE
- ELECTRICAL:  
 A. IMPEDANCE: 50 OHMS, NOMINAL  
 B. FREQUENCY RANGE: 0 TO 6 GHz  
 C. VSWR: 1.10 + 0.06 x F (GHz) MAX, FROM 0 TO 3 GHz  
 0.56 + 0.24 x F (GHz) MAX, FROM 3 TO 6 GHz  
 D. SEE 349-50861 FOR RECOMMENDED LAUNCH
- PACKAGING:  
 A. SINGLE PACK IN BAG.  
 B. MARK BAG OR TAG: AMPHENOL RF  
 920-251J-51P  
 DATE CODE (YYWW)
- ADD DIM "B" FROM PLUG AND DIM "A" FROM JACK OF TWO MATING CONNECTORS TO FIND THE NOMINAL BOARD-TO-BOARD SPACING.  
 AXIAL FLOAT IS ± 0.50 [0.020"]  
 RADIAL FLOAT IS ± 0.38 [0.015"]

THIRD ANGLE PROJ.

REVISIONS

REV	DESCRIPTION	DATE	ECO	APPR
A	RELEASE TO MFG.	--	49535	CL

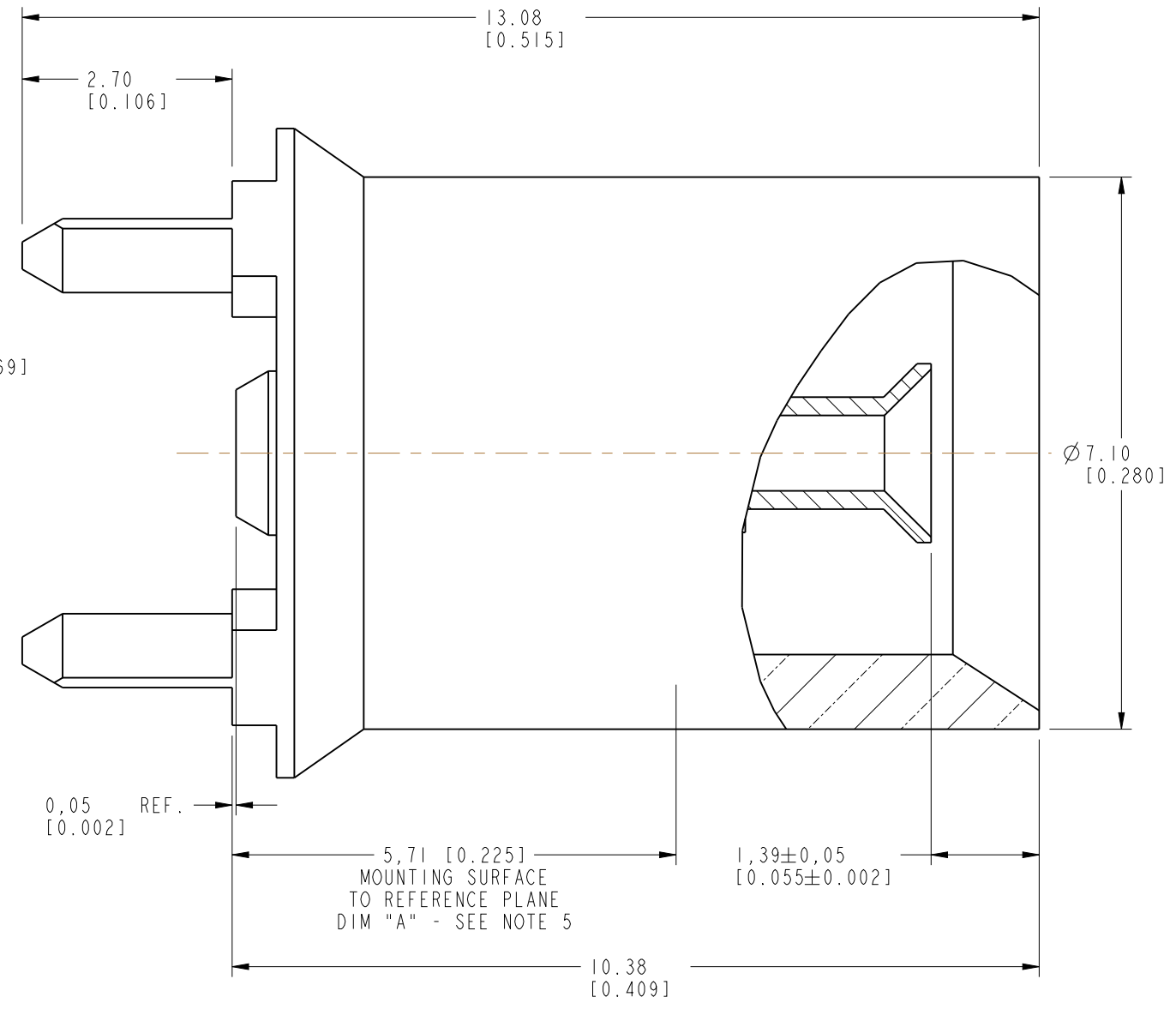
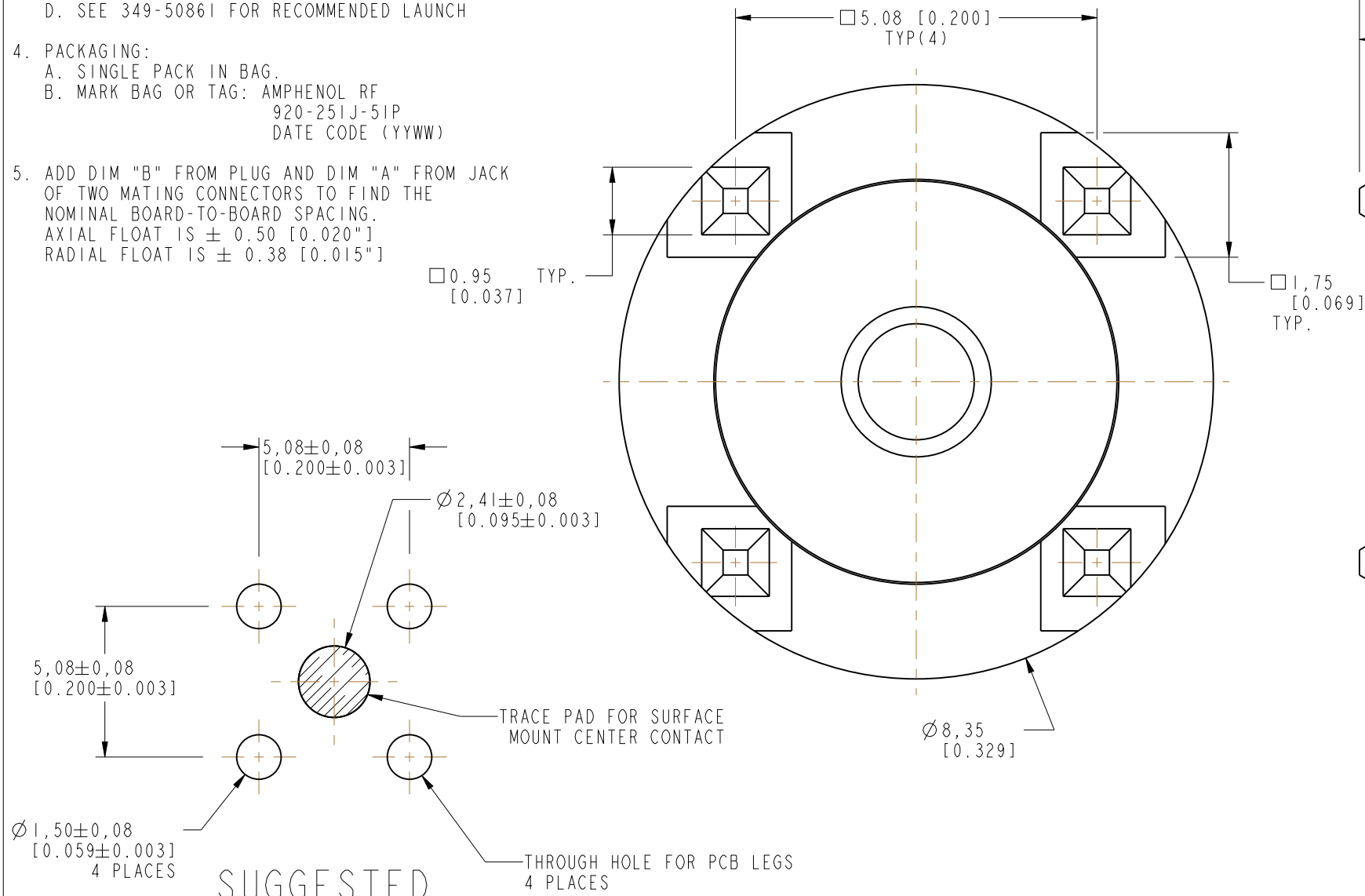
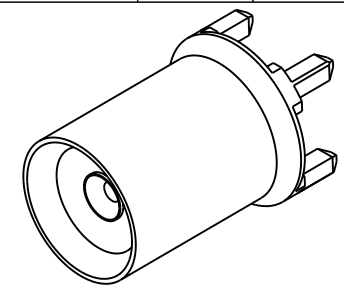

SUGGESTED  
PCB FOOTPRINT

**CUSTOMER OUTLINE DRAWING**  
 ALL OTHER SHEETS ARE FOR INTERNAL USE ONLY

UNLESS OTHERWISE SPECIFIED, DIMENSIONS ARE IN METRIC AND TOLERANCES ARE: < 0.5mm ± 0.05mm    0.5 - 6mm ± 0.1mm    6 - 30mm ± 0.2mm    30 - 120mm ± 0.3mm    ANGLES ± 1°	MATERIAL	DRAWN	DATE	TITLE AFI STR JACK PCB MOUNT	Amphenol RF www.amphenolrf.com
	SEE NOTES	ABHAYA KISHORE	20-Aug-12		
NOTICE - These drawings, specifications, or other data (1) are, and remain the property of Amphenol corp. (2) must be returned upon request; and (3) are confidential and not to be disclosed to any person other than those to whom they are given by Amphenol Corp. the finishing of these drawings, specifications, or other data by Amphenol Corp., or to any other person for any purpose is not to be regarded by implication or otherwise in any manner licensing, granting rights to permitting such holder or any other sperson to manufacture, use or sell any product, process or design, patented or otherwise, that may in any way be related to or disclosed by said drawings, specifications, or other data.	REFERENCE	ENGINEER	DATE	SCALE: 12.0:1.0   SHEET 2 OF 2	DRAWING NO. 920-251J-51P ITEM NO. 920-251J-51P PART NO. 920-251J-51P
	EAR # 3289	T. SMITH	20-Aug-12		
	CONFIGURATION LEVEL: In Work	APPROVED	CAD FILE	DATE	DWG SIZE B    REV A
FINISH					