

✓ 54/74175 011541  
 ✓ 54S/74S175 011544  
 ✓ 54LS/74LS175  
 QUAD D FLIP-FLOP 011543

*A version put on w/rote*

**DESCRIPTION** — The '175 is a high speed quad D flip-flop. The device is useful for general flip-flop requirements where clock and clear inputs are common. The information on the D inputs is stored during the LOW-to-HIGH clock transition. Both true and complemented outputs of each flip-flop are provided. A Master Reset input resets all flip-flops, independent of the Clock or D inputs, when LOW.

- EDGE-TRIGGERED D-TYPE INPUTS
- BUFFERED POSITIVE EDGE-TRIGGERED CLOCK
- ASYNCHRONOUS COMMON RESET
- TRUE AND COMPLEMENT OUTPUT

**ORDERING CODE:** See Section 9

PKGS	PIN OUT	COMMERCIAL GRADE	MILITARY GRADE	PKG TYPE
		V <sub>CC</sub> = +5.0 V ±5% T <sub>A</sub> = 0°C to +70°C	V <sub>CC</sub> = +5.0 V ±10%, T <sub>A</sub> = -55°C to +125°C	
Plastic DIP (P)	A	74175PC, 74S175PC 74LS175PC		9B
Ceramic DIP (D)	A	74175DC, 74S175DC 74LS175DC	54175DM, 54S175DM 54LS175DM	6B
Flatpak (F)	A	74175FC, 74S175FC 74LS175FC	54175FM, 54S175FM 54LS175FM	4L

**CONNECTION DIAGRAM  
PINOUT A**

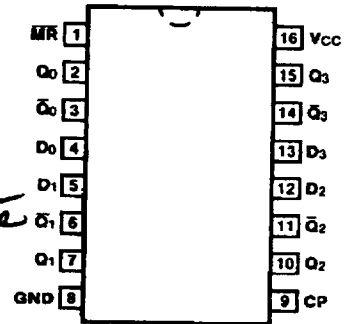

**LOGIC SYMBOL**

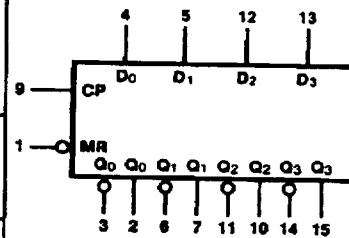

V<sub>CC</sub> = Pin 16  
GND = Pin 8

**INPUT LOADING/FAN-OUT:** See Section 3 for U.L. definitions

PIN NAMES	DESCRIPTION	54/74 (U.L.) HIGH/LOW	54/74S (U.L.) HIGH/LOW	54/74LS (U.L.) HIGH/LOW
D <sub>0</sub> — D <sub>3</sub>	Data Inputs	1.0/1.0	1.25/1.25	0.5/0.25
CP	Clock Pulse Input (Active Rising Edge)	1.0/1.0	1.25/1.25	0.5/0.25
MR	Master Reset Input (Active LOW)	1.0/1.0	1.25/1.25	0.5/0.25
Q <sub>0</sub> — Q <sub>3</sub>	True Outputs	20/10	25/12.5	10/5.0 (2.5)
Q <sub>0</sub> — Q <sub>3</sub>	Complement Outputs	20/10	25/12.5	10/5.0 (2.5)

**FUNCTIONAL DESCRIPTION** — The '175 consists of four edge-triggered D flip-flops with individual D inputs and Q and  $\bar{Q}$  outputs. The Clock and Master Reset are common. The four flip-flops will store the state of their individual D inputs on the LOW-to-HIGH clock (CP) transition, causing individual Q and  $\bar{Q}$  outputs to follow. A LOW input on the Master Reset ( $\overline{MR}$ ) will force all Q outputs LOW and  $\bar{Q}$  outputs HIGH independent of Clock or Data inputs. The '175 is useful for general logic applications where a common Master Reset and Clock are acceptable.

#### TRUTH TABLE

INPUTS		OUTPUTS	
@ $t_n, \overline{MR} = H$		@ $t_{n+1}$	
$D_n$		$Q_n$	$\bar{Q}_n$
L		L	H
H		H	L

$t_n$  = Bit time before clock positive-going transition  
 $t_{n+1}$  = Bit time after clock positive-going transition  
 H = HIGH Voltage Level  
 L = LOW Voltage Level

#### LOGIC DIAGRAM

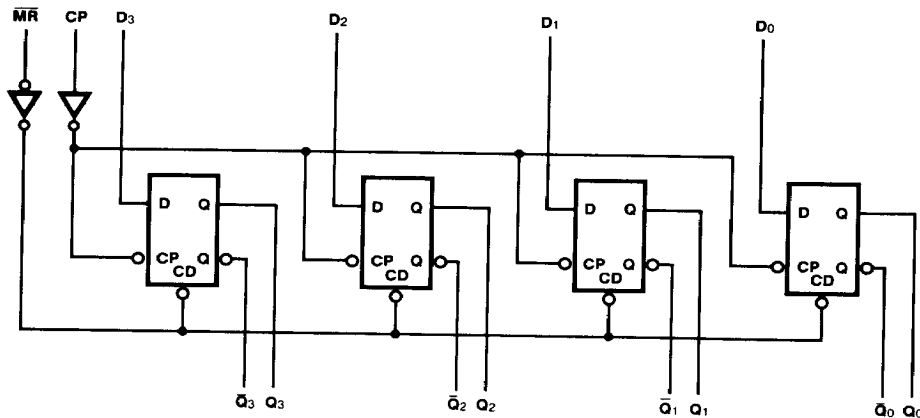

**DC CHARACTERISTICS OVER OPERATING TEMPERATURE RANGE** (unless otherwise specified)

SYMBOL	PARAMETER	54/74		54/74S		54/74LS		UNITS	CONDITIONS
		Min	Max	Min	Max	Min	Max		
I <sub>CC</sub>	Power Supply Current	45		96		18		mA	V <sub>CC</sub> = Max D <sub>n</sub> = $\overline{\text{MR}}$ = 4.5 V CP = 

**AC CHARACTERISTICS:** V<sub>CC</sub> = +5.0 V, T<sub>A</sub> = +25°C (See Section 3 for waveforms and load configurations)

SYMBOL	PARAMETER	54/74		54/74S		54/74LS		UNITS	CONDITIONS
		C <sub>L</sub> = 15 pF R <sub>L</sub> = 400 Ω		C <sub>L</sub> = 15 pF R <sub>L</sub> = 280 Ω		C <sub>L</sub> = 15 pF			
		Min	Max	Min	Max	Min	Max		
f <sub>max</sub>	Maximum Clock Frequency	25		75		30		MHz	Figs. 3-1, 3-8
t <sub>PLH</sub> t <sub>PHL</sub>	Propagation Delay CP to Q <sub>n</sub>	30 35		12 17		25 25		ns	Figs. 3-1, 3-8
t <sub>PHL</sub>	Propagation Delay $\overline{\text{MR}}$ to Q <sub>n</sub>	35		22		33		ns	Figs. 3-1, 3-16
t <sub>PLH</sub>	Propagation Delay $\overline{\text{MR}}$ to $\overline{\text{Q}}_n$	25		15		24		ns	Figs. 3-1, 3-16

**AC OPERATING REQUIREMENTS:** V<sub>CC</sub> = +5.0 V, T<sub>A</sub> = +25°C

SYMBOL	PARAMETER	54/74		54/74S		54/74LS		UNITS	CONDITIONS
		Min	Max	Min	Max	Min	Max		
t <sub>s</sub> (H) t <sub>s</sub> (L)	Setup Time HIGH or LOW D <sub>n</sub> to CP	20		5.0		10		ns	Fig. 3-6
t <sub>h</sub> (H) t <sub>h</sub> (L)	Hold Time HIGH or LOW D <sub>n</sub> to CP	5.0		3.0		5.0			
t <sub>w</sub> (H)	CP Pulse Width HIGH	20		7.0		15		ns	Fig. 3-8
t <sub>w</sub> (L)	$\overline{\text{MR}}$ Pulse Width LOW	20		7.0		18		ns	Fig. 3-16
t <sub>rec</sub>	Recovery Time $\overline{\text{MR}}$ to CP	25		5.0		12		ns	Fig. 3-16

4