

Bluetooth® Module

BR-C40# Class1, Class2, and Class3 Bluetooth® ver2.0

OUTLINE

- **AT HOME. AT WORK. ON THE ROAD. USING BLUETOOTH WIRELESS TECHNOLOGY MEANS TOTAL FREEDOM FROM THE CONSTRAINTS AND CLUTTER OF WIRES IN YOUR LIFE.**
- Wireless communications module certified to *Bluetooth®* ver2.0.
- Two types of models: With/without ceramic RF chip antenna provided.
- FCC, IC, CE, RoHS, and *Bluetooth®* certified ISM 2.4GHz band module.
- UART data interface (2-wire or 4-wire with CTS/RTS).
- 13-bit PCM, 8k samples/s, synchronous bidirectional audio interface
- Includes integrated software stack, profiles, and AT modem like commands.
- Embedded *Bluetooth* Stack Profiles Included (*requires no host MCU stack*): SPP, DUN, LAN, Headset, HFP, eSCO, SCO, Audio Gateway, FTP Client/Server, OBEX, OPP – Push/Pull, GAP SDP, RFCOMM, and L2CAP protocols.



FEATURES

- The *BlueRadios* serial radio modems can be configured, commanded, and controlled through simple ASCII strings over the *Bluetooth* RF link or directly through the hardware serial UART.
- Dedicated PCM voice channel for audio applications, and eSCO for exceptional audio clarity
- UART baud rate speeds: 1200bps up to 921.6Kbps, and customized
- +100 meter (330 feet) distance
- Software adjustable transmitter power from short to long range applications
- Low power consumption (80mA TX, 40mA RX, 1.4mA idle mode, and 30uA deep sleep)
- Small-form factor SMT radio modem
- Operating temperature range: -40~+70°C.
- Secure and robust communication link
 - ✓ FHSS (Frequency Hopping Spread Spectrum)
 - ✓ Encryption and 16 alphanumeric Personal Identification Number (PIN)
 - ✓ Error correction schemes for guaranteed packet delivery



Pb-Free

SPECIFICATIONS

Item	Specifications
Frequency	2402 ~ 2480MHz
Modulation	FHSS/GFSK
Channel intervals	1MHz
Number of channels	79CH
Power supply voltage	3.3Vdc ± 0.1V and < 10mVp-p noise
Current consumption	120mA worst case peak
Transmission rate (over the air)	721kbps
Receive sensitivity	-83dBm typ.
Output level (variable)	12dBm max.
Dimensions	Without antenna
	With antenna
	13.2(W)X18.8(L)X2.05(H)mm
	13.2(W)X24.8(L)X2.05(H)mm

DIMENSIONS

● **BR-C40N (Without Antenna)** *make from WML-C40NH*

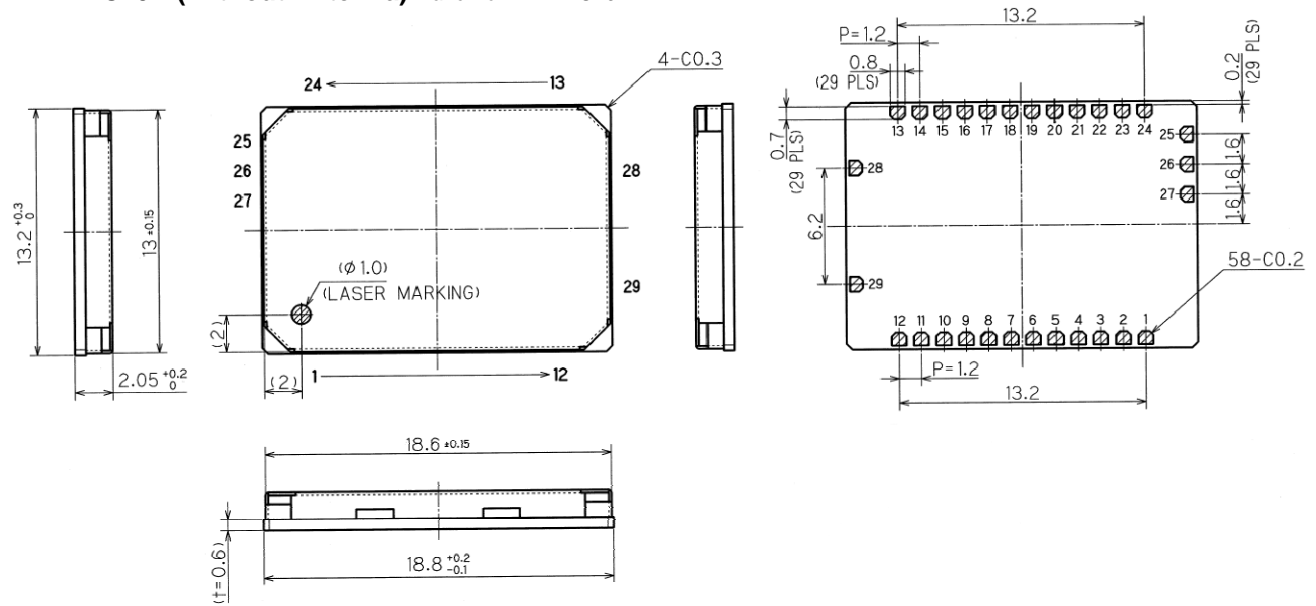

Note: SPI is for *BlueRadios* internal use only. Part is not 5Vdc tolerant. Reset is active **low**; pulse >5msec. Unused pins can float accept for PIO(4), tie to ground if not used or disable via software.

TERMINALS	
1. GND	15. UART_RTS
2. SPI_MOSI	16. UART_CTS
3. PIO[6]	17.
4. PIO[7]	18.
5. RESET	19. PIO[2]
6. SPI_CLK	20. PIO[3]
7. PCM_CLK	21. PIO[5]
8. PCM_SYNC	22. PIO[4]
9. PCM_IN	23. SPI_CSB
10. PCM_OUT	24. SPI_MISO
11. VDD (3.3Vdc)	25. GND
12. GND	26. ANT (External)
13. UART_RX	27. GND
14. UART_TX	28, 29 GND

Power-up Sequence

The module must be reset with terminal 5 “RESET” after turning on the power supply VDD. Reset terminal should be **low** for >5 msec. to cause a reset incase of electrical “brown-out” or poor input supplied VDD. Unit will not initially boot-up reliably if the VDD ramp rate is in milliseconds. Allow 1sec for module to fully reboot.

Please refer to BlueRadios Specification BR-AT_COMMANDS-100 hardware and software interface definition.

Firmware Options

- AT Command
 - Multi-point
 - Point-to-point
 - Repeater
- HCI or BCSP
- Custom

Unit: mm

*For technical details of the products in this page, refer to Sales Dept., BlueRadios, Inc.

STANDARD LAND DIMENSIONS

● **BR-C40N (Without Antenna)** *make from WML-C40NH*

Please refer to "Antenna matching application note", "Antenna placement application note" and "Antenna strip design note" to locate the Strip Line and GND plane around the module.

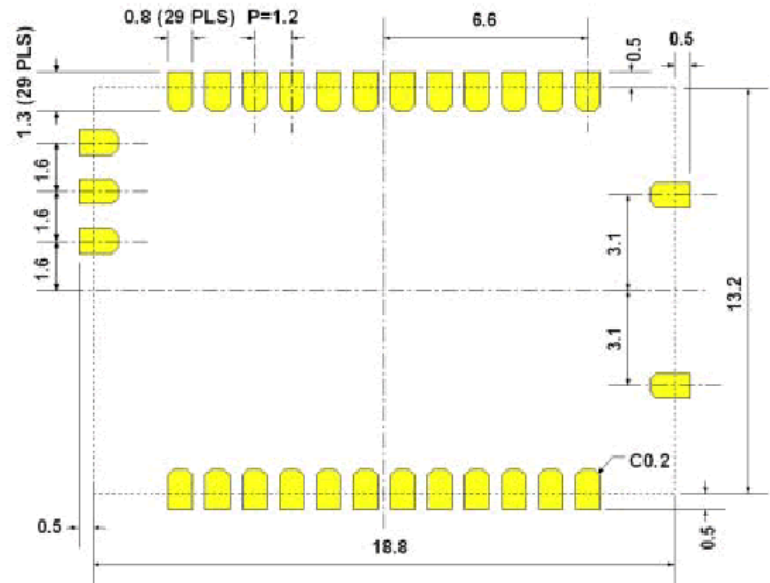

● **BR-C40A (With Antenna)** *make from WML-C40AH*

As indicated, the module should be placed on the board with protruding its antenna part from the customer PWB.

In this area, you should not locate anything parts or GND plane / Patterns on surface or internal layer.

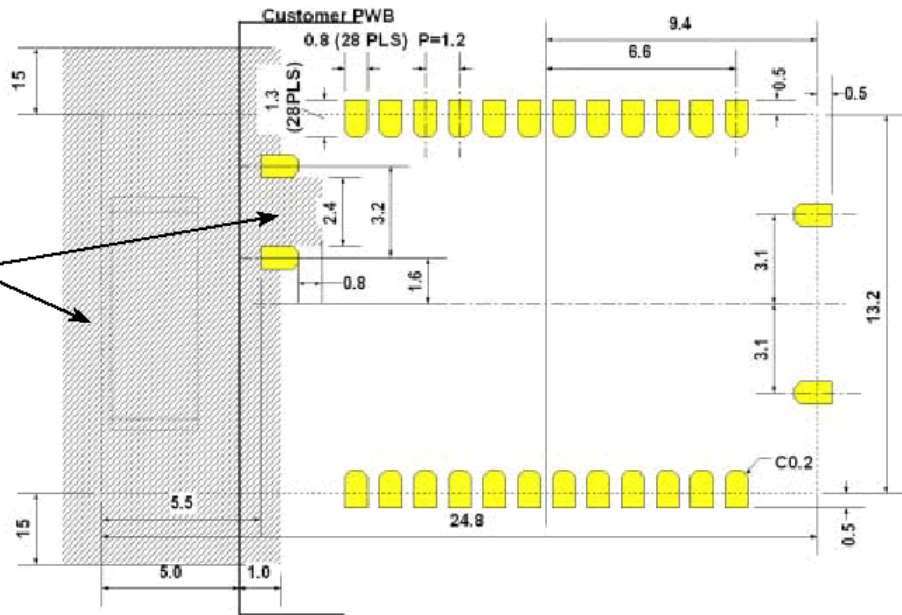

Note: Radio requires a RF ground plane on the rest of the Printed Circuit Board (PCB) area. This can be located on any layer of the PCB. Extend the RF ground plane parallel to module pins 1 and 24 the entire length of your board. Connect all ground pins and do not notch the ground plane around the module. Bottom of module is grounded so be careful of vias or conductive traces located under the modules that are not soldered masked to prevent shorting. Keep metallic components, connectors, copper traces, internal layers, and ground planes away from the antenna area in 3D space!