

Features

- Protects subscribers and equipment from destructive power crosses and lightning surges
- Reduces frequency of service calls
- Increases reliability of network operation
- Reduces cost of network maintenance
-  Listed per UL 497*

1965 Series – 50 Ohm Coaxial Surge Protector

The Bourns 1965 Series Coaxial Surge Protector is intended for use with low power VHF and UHF transmitters, 2-way base station transceivers, and receive-only systems. All models provide GDT technology. The 1965 arrester is symmetric and bidirectional. Either end may be used for the input or output. Various power and voltage choices are available - see specifications below for proper selection. Available with a choice of connectors.

Note: The arrester ground plate is common with the connector body; hence the coax cable shields will be grounded at their connection to the arrester.

Characteristics

Characteristic Impedance	50 Ω
Frequency Characteristics (DC - 1 GHz)	
VSWR (Max.)	<1.2:1
Transmission/Insertion Loss (Max.)	<0.2 dB
Impulse Discharge	
20 kA, 8/20 μ s	1 time
10 kA, 8/20 μ s	10 times
500 A, 10/1000 μ s	500 times
Arc Voltage (during discharge)	10 V
Operating Temperature	-40 ° to +85 °C
Maximum Operating Altitude	7,000 m

Impulse Sparkover (100 V/ μ s)	1965-20*	1965-35	1965-50	1965-60
100 V/ μ s	400 V	550 V	700 V	600 V
1 kV/ μ s	500 V	650 V	800 V	850 V
10 kV/ μ s	650 V	800 V	900 V	1100 V

*Model 1965-20-Axx is UL Listed per UL 497 for indoor/outdoor use in a listed, compatible NID.

VSWR and Insertion Loss

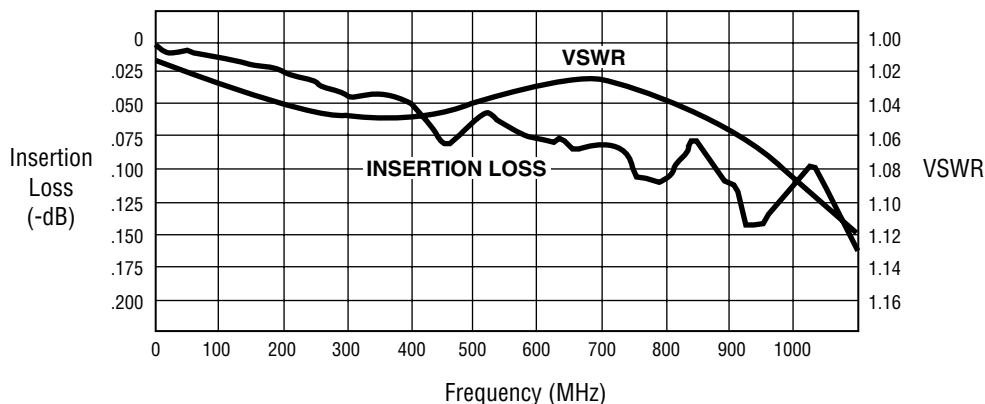

1965 Series – 50 Ohm Coaxial Surge Protector

BOURNS®

How to Order

How to Order Connector Fittings

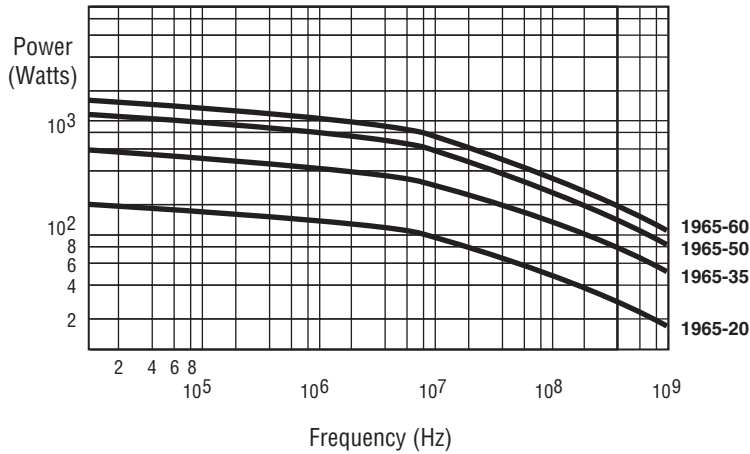

Part No.	Description
1965-xx-A00.....	N(f) and N(f)
1965-xx-A01.....	N(f) and N(m)
1965-xx-A04.....	BNC(f) and BNC(f)
1965-xx-A05.....	BNC(f) and BNC(m)
1965-xx-A12.....	UHF(f) and UHF(f)

Note: Radio frequency and transmit power should be known. The above curves apply to systems with a VSWR of 1.2:1 or less. Choose the protector whose curve lies first above the power-frequency coordinates of the radio system. For systems with a VSWR in excess of 1.2:1, or for a more exact determination if desired, multiply the actual radio power by the expression $0.83[2 \times \text{VSWR} \div (1 + \text{VSWR})]^2$, and use this new power value to enter the graph.

Product Dimensions

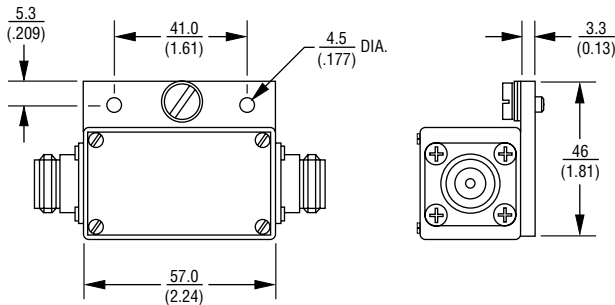

DIMENSIONS: $\frac{\text{MM}}{\text{(INCHES)}}$



Asia-Pacific:

Tel: +886-2 2562-4117 • Fax: +886-2 2562-4116

Europe:

Tel: +41-41 768 5555 • Fax: +41-41 768 5510

The Americas:

Tel: +1-951 781-5500 • Fax: +1-951 781-5700

www.bourns.com

REV. I 08/09

Specifications are subject to change without notice.
Customers should verify actual device performance in their specific applications