

FEATURES

Converts an ac voltage waveform to a dc voltage and then converts to the true rms, average rectified, or absolute value
200 mV rms full-scale input range (larger inputs with input attenuator)

High input impedance: $10^{12} \Omega$

Low input bias current: 25 pA maximum

High accuracy: $\pm 0.3 \text{ mV} \pm 0.3\%$ of reading

RMS conversion with signal crest factors up to 5

Wide power supply range: +2.8 V, -3.2 V to $\pm 16.5 \text{ V}$

Low power: 200 μA maximum supply current

Buffered voltage output

No external trims needed for specified accuracy

Related device: the AD737—features a power-down control with standby current of only 25 μA ; the dc output voltage is negative and the output impedance is 8 k Ω

GENERAL DESCRIPTION

The AD736 is a low power, precision, monolithic true rms-to-dc converter. It is laser trimmed to provide a maximum error of $\pm 0.3 \text{ mV} \pm 0.3\%$ of reading with sine wave inputs. Furthermore, it maintains high accuracy while measuring a wide range of input waveforms, including variable duty-cycle pulses and triac (phase)-controlled sine waves. The low cost and small size of this converter make it suitable for upgrading the performance of non-rms precision rectifiers in many applications. Compared to these circuits, the AD736 offers higher accuracy at an equal or lower cost.

The AD736 can compute the rms value of both ac and dc input voltages. It can also be operated as an ac-coupled device by adding one external capacitor. In this mode, the AD736 can resolve input signal levels of 100 μV rms or less, despite variations in temperature or supply voltage. High accuracy is also maintained for input waveforms with crest factors of 1 to 3. In addition, crest factors as high as 5 can be measured (introducing only 2.5% additional error) at the 200 mV full-scale input level.

The AD736 has its own output buffer amplifier, thereby providing a great deal of design flexibility. Requiring only 200 μA of power supply current, the AD736 is optimized for use in portable multimeters and other battery-powered applications.

FUNCTIONAL BLOCK DIAGRAM

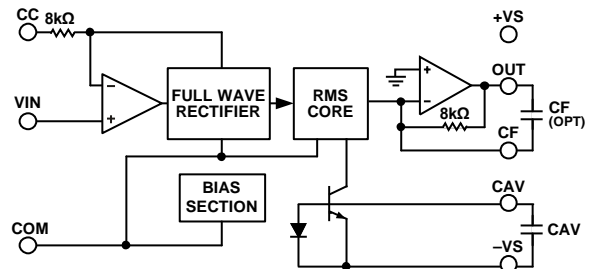

Figure 1.

The AD736 allows the choice of two signal input terminals: a high impedance FET input ($10^{12} \Omega$) that directly interfaces with High-Z input attenuators and a low impedance input (8 k Ω) that allows the measurement of 300 mV input levels while operating from the minimum power supply voltage of +2.8 V, -3.2 V. The two inputs can be used either single ended or differentially.

The AD736 has a 1% reading error bandwidth that exceeds 10 kHz for the input amplitudes from 20 mV rms to 200 mV rms while consuming only 1 mW.

The AD736 is available in four performance grades. The AD736J and AD736K grades are rated over the 0°C to +70°C and -20°C to +85°C commercial temperature ranges. The AD736A and AD736B grades are rated over the -40°C to +85°C industrial temperature range. The AD736 is available in three low cost, 8-lead packages: PDIP, SOIC, and CERDIP.

PRODUCT HIGHLIGHTS

1. The AD736 is capable of computing the average rectified value, absolute value, or true rms value of various input signals.
2. Only one external component, an averaging capacitor, is required for the AD736 to perform true rms measurement.
3. The low power consumption of 1 mW makes the AD736 suitable for many battery-powered applications.
4. A high input impedance of $10^{12} \Omega$ eliminates the need for an external buffer when interfacing with input attenuators.
5. A low impedance input is available for those applications that require an input signal up to 300 mV rms operating from low power supply voltages.

Rev. I

Information furnished by Analog Devices is believed to be accurate and reliable. However, no responsibility is assumed by Analog Devices for its use, nor for any infringements of patents or other rights of third parties that may result from its use. Specifications subject to change without notice. No license is granted by implication or otherwise under any patent or patent rights of Analog Devices. Trademarks and registered trademarks are the property of their respective owners.

TABLE OF CONTENTS

Features	1
General Description	1
Functional Block Diagram	1
Product Highlights	1
Revision History	2
Specifications.....	3
Absolute Maximum Ratings.....	5
Thermal Resistance	5
ESD Caution.....	5
Pin Configuration and Function Descriptions.....	6
Typical Performance Characteristics	7
Theory of Operation	10
Types of AC Measurement	10
Calculating Settling Time Using Figure 16.....	11

REVISION HISTORY

12/12—Rev. H to Rev. I

Changes to Features and Figure 1.....	1
Change to Error vs. Crest Factor Parameter, Table 1	3
Changes to Operating Voltage Range Parameter, Table 1	4
Changes to Table 2.....	5
Added Table 3; Renumbered Sequentially	5
Changes to Figure 9.....	8
Changes to Figure 16.....	9
Changes to Figure 18.....	10
Added Additional Application Concepts Section and	
Changes to Figure 25.....	15
Changes to Figure 29.....	17
Deleted Table 6.....	17
Changes to Ordering Guide	20

2/07—Rev. G to Rev. H

Updated Layout.....	9 to 12
Added Applications Section.....	13
Inserted Figure 21 to Figure 24; Renumbered Sequentially.....	13
Deleted Figure 25.....	15
Added Evaluation Board Section.....	16
Inserted Figure 29 to Figure 34; Renumbered Sequentially.....	16
Inserted Figure 35; Renumbered Sequentially.....	17
Added Table 6.....	17

2/06—Rev. F to Rev. G

Updated Format.....	Universal
---------------------	-----------

RMS Measurement—Choosing the Optimum Value for C_{AV}	11
Rapid Settling Times via the Average Responding	
Connection.....	12
DC Error, Output Ripple, and Averaging Error	12
AC Measurement Accuracy and Crest Factor.....	12
Applications.....	13
Connecting the Input.....	13
Selecting Practical Values for Input Coupling (C_C),	
Averaging (C_{AV}), and Filtering (C_F) Capacitors.....	14
Additional Application Concepts.....	15
Evaluation Board	17
Outline Dimensions	19
Ordering Guide	20

Changes to Features	1
Added Table 3	6
Changes to Figure 21 and Figure 22	14
Changes to Figure 23, Figure 24, and Figure 25	15
Updated Outline Dimensions.....	16
Changes to Ordering Guide	17

5/04—Rev. E to Rev. F

Changes to Specifications.....	2
Replaced Figure 18	10
Updated Outline Dimensions.....	16
Changes to Ordering Guide	16

4/03—Rev. D to Rev. E

Changes to General Description	1
Changes to Specifications.....	3
Changes to Absolute Maximum Ratings.....	4
Changes to Ordering Guide	4

11/02—Rev. C to Rev. D

Changes to Functional Block Diagram.....	1
Changes to Pin Configuration	3
Figure 1 Replaced	6
Changes to Figure 2.....	6
Changes to Application Circuits Figures 4 to 8.....	8
Outline Dimensions Updated.....	8

SPECIFICATIONS

At 25°C ± 5 V supplies, ac-coupled with 1 kHz sine wave input applied, unless otherwise noted. Specifications in **bold** are tested on all production units at final electrical test. Results from those tests are used to calculate outgoing quality levels.

Table 1.

Parameter	Conditions	AD736J/AD736A			AD736K/AD736B			Unit
		Min	Typ	Max	Min	Typ	Max	
TRANSFER FUNCTION		$V_{OUT} = \sqrt{Avg(V_{IN}^2)}$						
CONVERSION ACCURACY	1 kHz sine wave							
Total Error, Internal Trim ¹	Using C _C							
All Grades	0 mV rms to 200 mV rms		0.3/0.3	0.5/0.5		0.2/0.2	0.3/0.3	±mV/±% of reading
	200 mV to 1 V rms		-1.2	±2.0		-1.2	±2.0	% of reading
T _{MIN} to T _{MAX}								
A and B Grades	@ 200 mV rms		0.7/0.7				0.5/0.5	±mV/±% of reading
J and K Grades	@ 200 mV rms		0.007			0.007		±% of reading/°C
vs. Supply Voltage								
@ 200 mV rms Input	V _S = ±5 V to ±16.5 V	0	+0.06	+0.1	0	+0.06	+0.1	%/V
	V _S = ±5 V to ±3 V	0	-0.18	-0.3	0	-0.18	-0.3	%/V
DC Reversal Error, DC-Coupled	@ 600 mV dc		1.3	2.5		1.3	2.5	% of reading
Nonlinearity ² , 0 mV to 200 mV	@ 100 mV rms	0	0.25	0.35	0	0.25	0.35	% of reading
Total Error, External Trim	0 mV rms to 200 mV rms		0.1/0.5			0.1/0.3		±mV/±% of reading
ERROR VS. CREST FACTOR ³								
Crest Factor = 1 to 3	C _{AV} , C _F = 100 μF		0.7			0.7		% additional error
Crest Factor = 3 to 5	C _{AV} , C _F = 100 μF		2.5			2.5		% additional error
INPUT CHARACTERISTICS								
High Impedance Input								
Signal Range (Pin 2)								
Continuous RMS Level	V _S = +2.8 V, -3.2 V			200			200	mV rms
	V _S = ±5 V to ±16.5 V			1			1	V rms
Peak Transient Input	V _S = +2.8 V, -3.2 V	±0.9			±0.9			V
	V _S = ±5 V		±2.7			±2.7		V
	V _S = ±16.5 V	±4.0			±4.0			V
Input Resistance			10 ¹²			10 ¹²		Ω
Input Bias Current	V _S = ±3 V to ±16.5 V		1	25		1	25	pA
Low Impedance Input								
Signal Range (Pin 1)								
Continuous RMS Level	V _S = +2.8 V, -3.2 V			300			300	mV rms
	V _S = ±5 V to ±16.5 V			1			1	V rms
Peak Transient Input	V _S = +2.8 V, -3.2 V		±1.7			±1.7		V
	V _S = ±5 V		±3.8			±3.8		V
	V _S = ±16.5 V		±11			±11		V
Input Resistance		6.4	8	9.6	6.4	8	9.6	kΩ
Maximum Continuous Nondestructive Input	All supply voltages			±12			±12	V p-p
Input Offset Voltage ⁴								
J and K Grades				±3			±3	mV
A and B Grades				±3			±3	mV
vs. Temperature			8	30		8	30	μV/°C
vs. Supply	V _S = ±5 V to ±16.5 V		50	150		50	150	μV/V
	V _S = ±5 V to ±3 V		80			80		μV/V

Parameter	Conditions	AD736J/AD736A			AD736K/AD736B			Unit
		Min	Typ	Max	Min	Typ	Max	
OUTPUT CHARACTERISTICS								
Output Offset Voltage								
J and K Grades			±0.1	±0.5		±0.1	±0.3	mV
A and B Grades				±0.5			±0.3	mV
vs. Temperature			1	20		1	20	μV/°C
vs. Supply	$V_S = \pm 5\text{ V to } \pm 16.5\text{ V}$		50	130		50	130	μV/V
	$V_S = \pm 5\text{ V to } \pm 3\text{ V}$		50			50		μV/V
Output Voltage Swing								
2 kΩ Load	$V_S = +2.8\text{ V, } -3.2\text{ V}$	0 to	1.7		0 to	1.7		V
		1.6			1.6			
	$V_S = \pm 5\text{ V}$	0 to	3.8		0 to	3.8		V
		3.6			3.6			
	$V_S = \pm 16.5\text{ V}$	0 to 4	5		0 to 4	5		V
No Load	$V_S = \pm 16.5\text{ V}$	0 to 4	12		0 to 4	12		V
Output Current			2			2		mA
Short-Circuit Current			3			3		mA
Output Resistance	@ dc		0.2			0.2		Ω
FREQUENCY RESPONSE								
High Impedance Input (Pin 2) for 1% Additional Error	Sine wave input							
$V_{IN} = 1\text{ mV rms}$			1			1		kHz
$V_{IN} = 10\text{ mV rms}$			6			6		kHz
$V_{IN} = 100\text{ mV rms}$			37			37		kHz
$V_{IN} = 200\text{ mV rms}$			33			33		kHz
±3 dB Bandwidth	Sine wave input							
$V_{IN} = 1\text{ mV rms}$			5			5		kHz
$V_{IN} = 10\text{ mV rms}$			55			55		kHz
$V_{IN} = 100\text{ mV rms}$			170			170		kHz
$V_{IN} = 200\text{ mV rms}$			190			190		kHz
Low Impedance Input (Pin 1) for 1% Additional Error	Sine wave input							
$V_{IN} = 1\text{ mV rms}$			1			1		kHz
$V_{IN} = 10\text{ mV rms}$			6			6		kHz
$V_{IN} = 100\text{ mV rms}$			90			90		kHz
$V_{IN} = 200\text{ mV rms}$			90			90		kHz
±3 dB Bandwidth	Sine wave input							
$V_{IN} = 1\text{ mV rms}$			5			5		kHz
$V_{IN} = 10\text{ mV rms}$			55			55		kHz
$V_{IN} = 100\text{ mV rms}$			350			350		kHz
$V_{IN} = 200\text{ mV rms}$			460			460		kHz
POWER SUPPLY								
Operating Voltage Range		+2.8, -3.2	±5	±16.5	+2.8, -3.2	±5	±16.5	V
Quiescent Current	Zero signal		160	200		160	200	μA
200 mV rms, No Load	Sine wave input		230	270		230	270	μA
TEMPERATURE RANGE								
Operating, Rated Performance								
Commercial	0°C to 70°C		AD736JN, AD736JR			AD736KN, AD736KR		
Industrial	-40°C to +85°C		AD736AQ, AD736AR			AD736BQ, AD736BR		

¹ Accuracy is specified with the AD736 connected as shown in Figure 18 with Capacitor C_c .

² Nonlinearity is defined as the maximum deviation (in percent error) from a straight line connecting the readings at 0 mV rms and 200 mV rms. Output offset voltage is adjusted to zero.

³ Error vs. crest factor is specified as additional error for a 200 mV rms signal. Crest factor = V_{PEAK}/V_{RMS} .

⁴ DC offset does not limit ac resolution.

ABSOLUTE MAXIMUM RATINGS

Table 2.

Parameter	Rating
Supply Voltage	± 16.5 V
Internal Power Dissipation	200 mW
Input Voltage	
Pin 2 through Pin 8	$\pm V_S$
Pin 1	± 12 V
Output Short-Circuit Duration	Indefinite
Differential Input Voltage	$+V_S$ and $-V_S$
Storage Temperature Range (Q)	-65°C to $+150^\circ\text{C}$
Storage Temperature Range (N, R)	-65°C to $+125^\circ\text{C}$
Lead Temperature (Soldering, 60 sec)	300°C
ESD Rating	500 V

Stresses above those listed under Absolute Maximum Ratings may cause permanent damage to the device. This is a stress rating only; functional operation of the device at these or any other conditions above those indicated in the operational section of this specification is not implied. Exposure to absolute maximum rating conditions for extended periods may affect device reliability.

THERMAL RESISTANCE

θ_{JA} is specified for the worst-case conditions, that is, a device soldered in a circuit board for surface-mount packages.

Table 3. Thermal Resistance

Package Type	θ_{JA}	Unit
8-Lead PDIP	165	$^\circ\text{C}/\text{W}$
8-Lead CERDIP	110	$^\circ\text{C}/\text{W}$
8-Lead SOIC	155	$^\circ\text{C}/\text{W}$

ESD CAUTION



ESD (electrostatic discharge) sensitive device. Charged devices and circuit boards can discharge without detection. Although this product features patented or proprietary protection circuitry, damage may occur on devices subjected to high energy ESD. Therefore, proper ESD precautions should be taken to avoid performance degradation or loss of functionality.

PIN CONFIGURATION AND FUNCTION DESCRIPTIONS

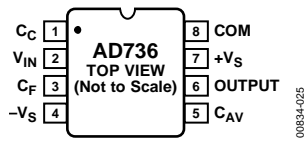

Figure 2. Pin Configuration

Table 4. Pin Function Descriptions

Pin No.	Mnemonic	Description
1	C_C	Coupling Capacitor. If dc coupling is desired at Pin 2, connect a coupling capacitor to this pin. If the coupling at Pin 2 is ac, connect this pin to ground. Note that this pin is also an input, with an input impedance of 8 k Ω . Such an input is useful for applications with high input voltages and low supply voltages.
2	V_{IN}	High Input Impedance Pin.
3	C_F	Connect an Auxiliary Low-Pass Filter Capacitor from the Output.
4	$-V_S$	Negative Supply Voltage if Dual Supplies Are Used, or Ground if Connected to a Single-Supply Source.
5	C_{AV}	Connect the Averaging Capacitor Here.
6	OUTPUT	DC Output Voltage.
7	$+V_S$	Positive Supply Voltage.
8	COM	Common.

TYPICAL PERFORMANCE CHARACTERISTICS

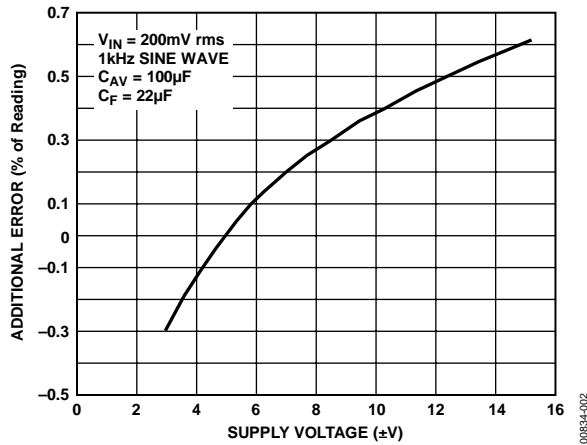

Figure 3. Additional Error vs. Supply Voltage

00834-002

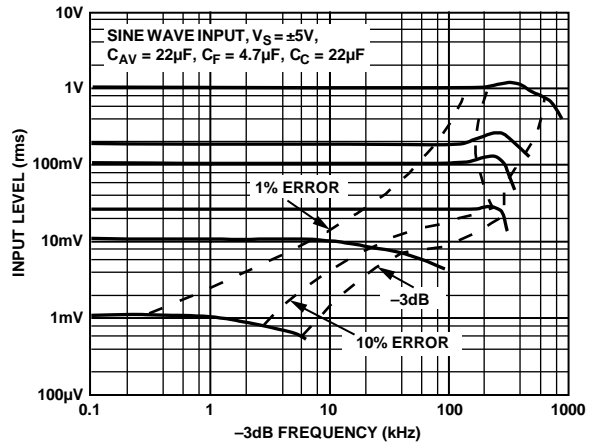

Figure 6. Frequency Response Driving Pin 1

00834-005

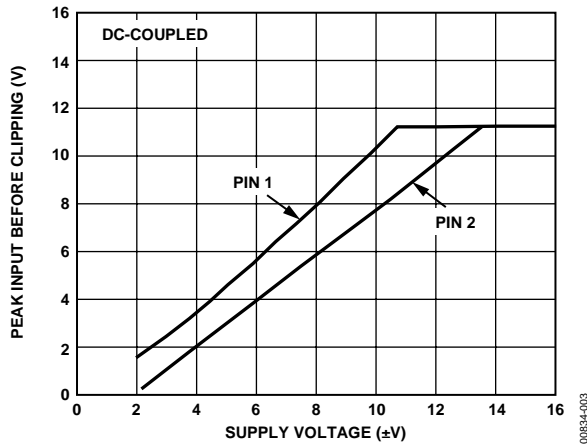

Figure 4. Maximum Input Level vs. Supply Voltage

00834-003

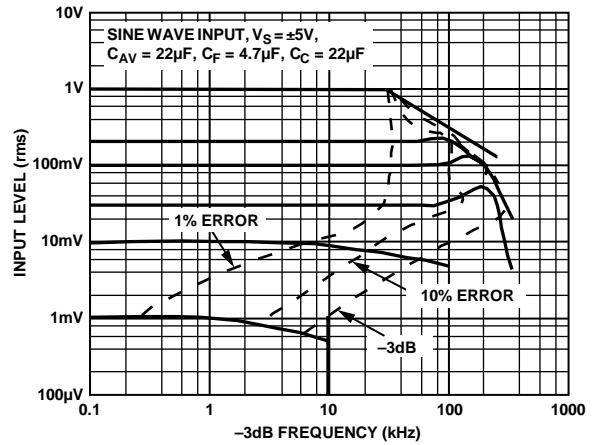

Figure 7. Frequency Response Driving Pin 2

00834-006

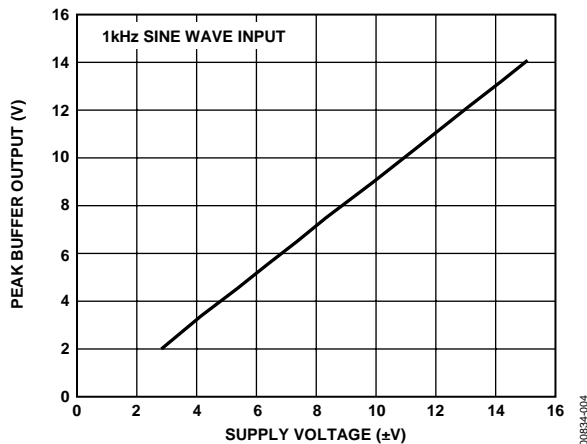

Figure 5. Peak Buffer Output vs. Supply Voltage

00834-004

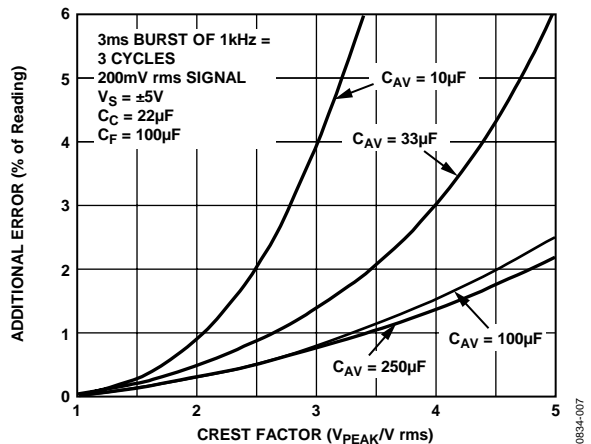

Figure 8. Additional Error vs. Crest Factor with Various Values of C_{AV}

00834-007

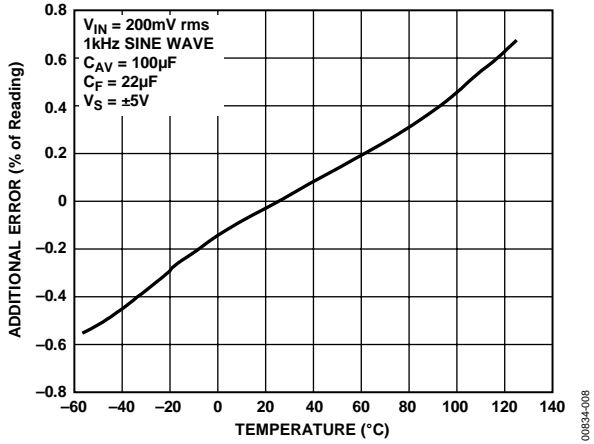

Figure 9. Additional Error vs. Temperature

00834-008

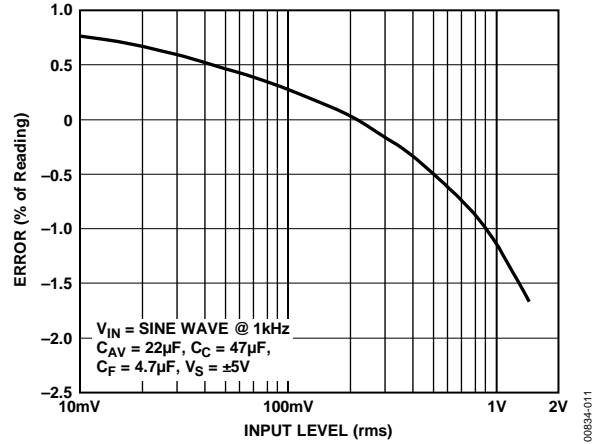

Figure 12. Error vs. RMS Input Voltage (Pin 2), Output Buffer Offset Is Adjusted to Zero

00834-011

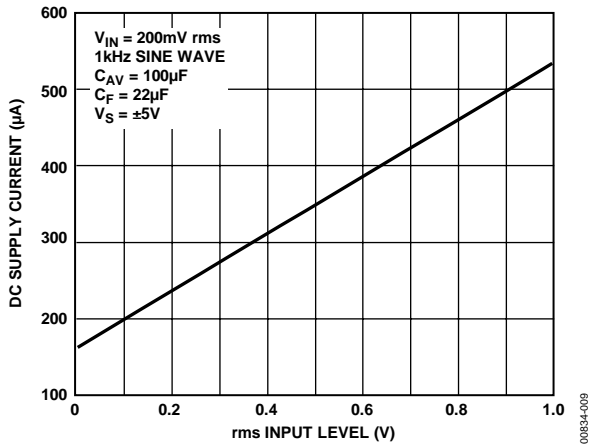

Figure 10. DC Supply Current vs. rms Input Level

00834-009

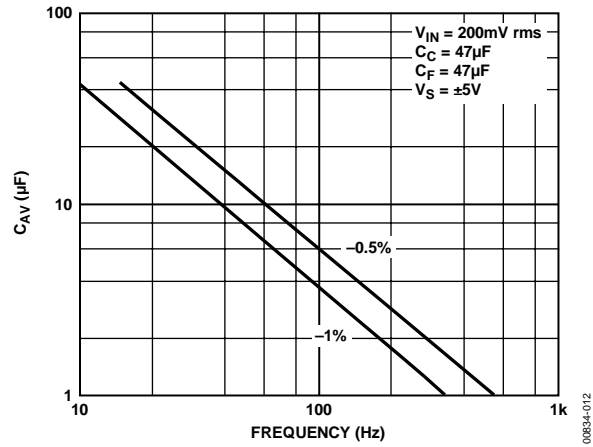

Figure 13. C_{AV} vs. Frequency for Specified Averaging Error

00834-012

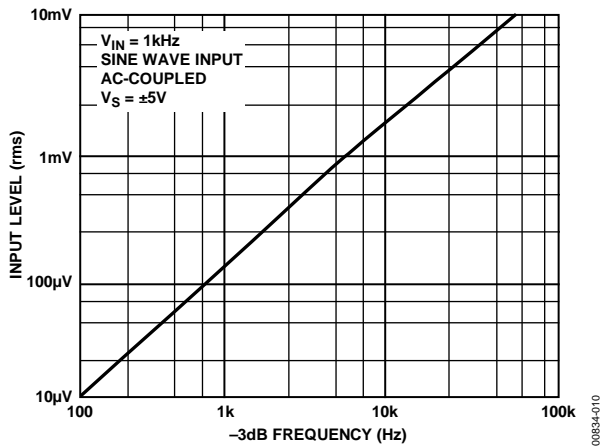

Figure 11. RMS Input Level (Pin 2) vs. -3 dB Frequency

00834-010

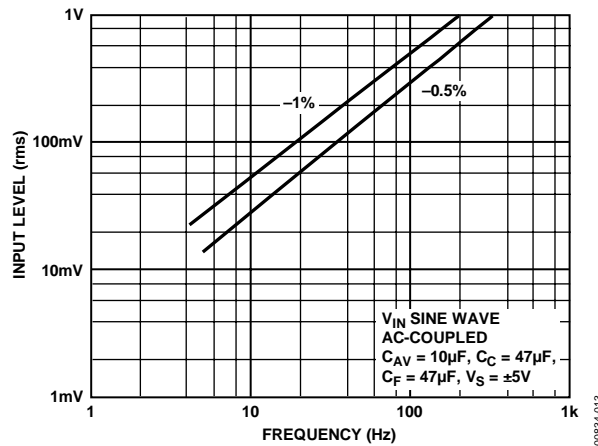

Figure 14. RMS Input Level vs. Frequency for Specified Averaging Error

00834-013

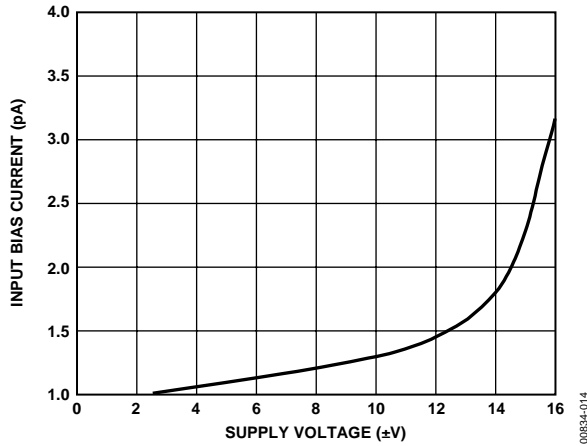

Figure 15. Pin 2 Input Bias Current vs. Supply Voltage

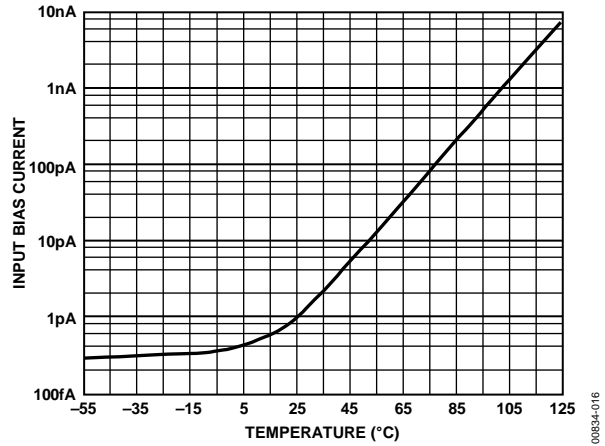

Figure 17. Pin 2 Input Bias Current vs. Temperature

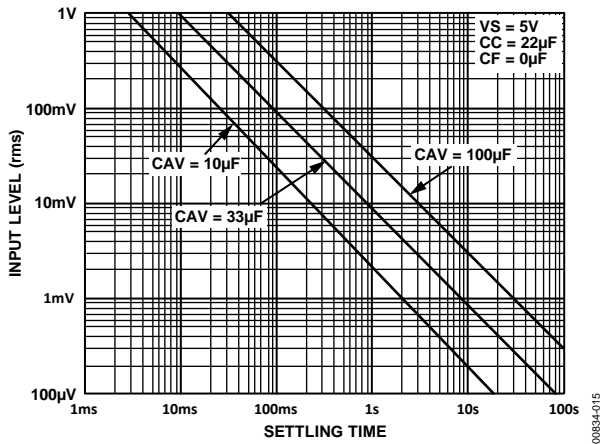

Figure 16. RMS Input Level for Various Values of C_{AV} vs. Settling Time

THEORY OF OPERATION

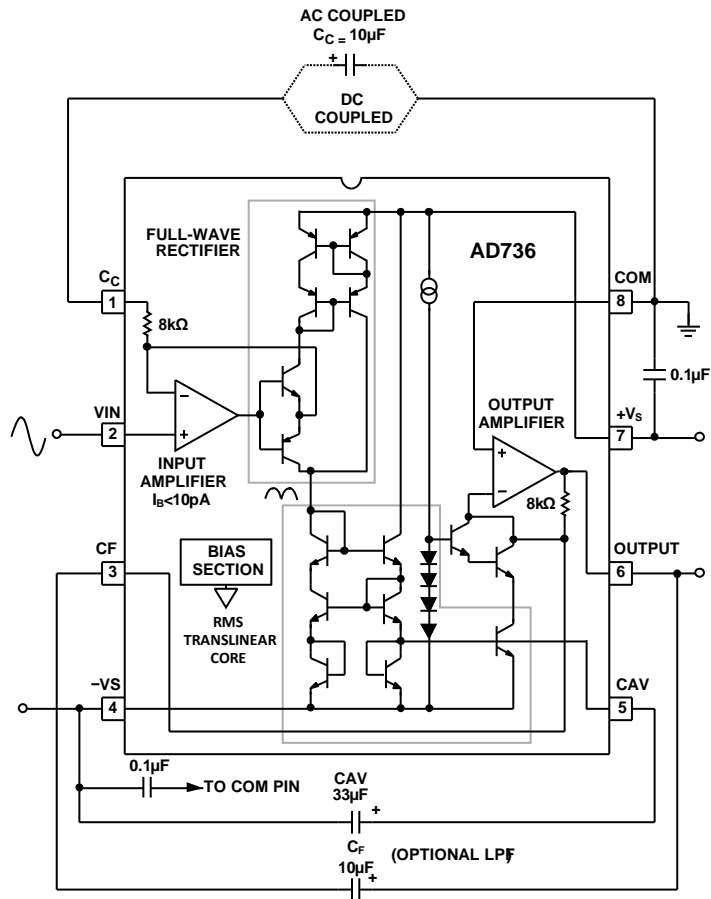

Figure 18. AD736 True RMS Circuit

As shown by Figure 18, the AD736 has five functional subsections: the input amplifier, full-wave rectifier (FWR), rms core, output amplifier, and bias section. The FET input amplifier allows both a high impedance, buffered input (Pin 2) and a low impedance, wide dynamic range input (Pin 1). The high impedance input, with its low input bias current, is well suited for use with high impedance input attenuators.

The output of the input amplifier drives a full-wave precision rectifier that, in turn, drives the rms core. The essential rms operations of squaring, averaging, and square rooting are performed in the core using an external averaging capacitor, C_{AV} . Without C_{AV} , the rectified input signal travels through the core unprocessed, as is done with the average responding connection (see Figure 19).

A final subsection, an output amplifier, buffers the output from the core and allows optional low-pass filtering to be performed via the external capacitor, C_F , which is connected across the feedback path of the amplifier. In the average responding connection, this is where all of the averaging is carried out. In the rms circuit, this additional filtering stage helps reduce any output ripple that was not removed by the averaging capacitor, C_{AV} .

TYPES OF AC MEASUREMENT

The AD736 is capable of measuring ac signals by operating as either an average responding converter or a true rms-to-dc converter. As its name implies, an average responding converter computes the average absolute value of an ac (or ac and dc) voltage or current by full-wave rectifying and low-pass filtering the input signal; this approximates the average. The resulting output, a dc average level, is scaled by adding (or reducing) gain; this scale factor converts the dc average reading to an rms equivalent value for the waveform being measured. For example, the average absolute value of a sine wave voltage is 0.636 times V_{PEAK} ; the corresponding rms value is $0.707 \times V_{PEAK}$. Therefore, for sine wave voltages, the required scale factor is 1.11 ($0.707/0.636$).

In contrast to measuring the average value, true rms measurement is a universal language among waveforms, allowing the magnitudes of all types of voltage (or current) waveforms to be compared to one another and to dc. RMS is a direct measure of the power or heating value of an ac voltage compared to that of a dc voltage; an ac signal of 1 V rms produces the same amount of heat in a resistor as a 1 V dc signal.

Mathematically, the rms value of a voltage is defined (using a simplified equation) as

$$V_{\text{rms}} = \sqrt{\text{Avg}(V^2)}$$

This involves squaring the signal, taking the average, and then obtaining the square root. True rms converters are smart rectifiers; they provide an accurate rms reading regardless of the type of waveform being measured. However, average responding converters can exhibit very high errors when their input signals deviate from their precalibrated waveform; the magnitude of the error depends on the type of waveform being measured. For example, if an average responding converter is calibrated to measure the rms value of sine wave voltages and then is used to measure either symmetrical square waves or dc voltages, the converter has a computational error 11% (of reading) higher than the true rms value (see Table 5).

CALCULATING SETTling TIME USING FIGURE 16

Figure 16 can be used to closely approximate the time required for the AD736 to settle when its input level is reduced in amplitude. The net time required for the rms converter to settle is the difference between two times extracted from the graph (the initial time minus the final settling time). As an example, consider the following conditions: a 33 μF averaging capacitor, a 100 mV initial rms input level, and a final (reduced) 1 mV input level. From Figure 16, the initial settling time (where the 100 mV line intersects the 33 μF line) is approximately 80 ms.

The settling time corresponding to the new or final input level of 1 mV is approximately 8 seconds. Therefore, the net time for the circuit to settle to its new value is 8 seconds minus 80 ms, which is 7.92 seconds. Note that because of the smooth decay characteristic inherent with a capacitor/diode combination, this is the total settling time to the final value (that is, not the settling time to 1%, 0.1%, and so on, of the final value). In addition, this graph provides the worst-case settling time because the AD736 settles very quickly with increasing input levels.

RMS MEASUREMENT—CHOOSING THE OPTIMUM VALUE FOR C_{AV}

Because the external averaging capacitor, C_{AV} , holds the rectified input signal during rms computation, its value directly affects the accuracy of the rms measurement, especially at low frequencies. Furthermore, because the averaging capacitor appears across a diode in the rms core, the averaging time constant increases exponentially as the input signal is reduced. This means that as the input level decreases, errors due to nonideal averaging decrease, and the time required for the circuit to settle to the new rms level increases. Therefore, lower input levels allow the circuit to perform better (due to increased averaging) but increase the waiting time between measurements. Obviously, when selecting C_{AV} , a trade-off between computational accuracy and settling time is required.

Table 5. Error Introduced by an Average Responding Circuit when Measuring Common Waveforms

Waveform Type 1 V Peak Amplitude	Crest Factor ($V_{\text{PEAK}}/V_{\text{rms}}$)	True RMS Value (V)	Average Responding Circuit Calibrated to Read RMS Value of Sine Waves (V)	% of Reading Error Using Average Responding Circuit
Undistorted Sine Wave	1.414	0.707	0.707	0
Symmetrical Square Wave	1.00	1.00	1.11	+11.0
Undistorted Triangle Wave	1.73	0.577	0.555	-3.8
Gaussian Noise (98% of Peaks <1 V)	3	0.333	0.295	-11.4
Rectangular	2	0.5	0.278	-44
Pulse Train	10	0.1	0.011	-89
SCR Waveforms				
50% Duty Cycle	2	0.495	0.354	-28
25% Duty Cycle	4.7	0.212	0.150	-30

RAPID SETTLING TIMES VIA THE AVERAGE RESPONDING CONNECTION

Because the average responding connection shown in Figure 19 does not use the C_{AV} averaging capacitor, its settling time does not vary with the input signal level. It is determined solely by the RC time constant of C_F and the internal 8 k Ω resistor in the output amplifier's feedback path.

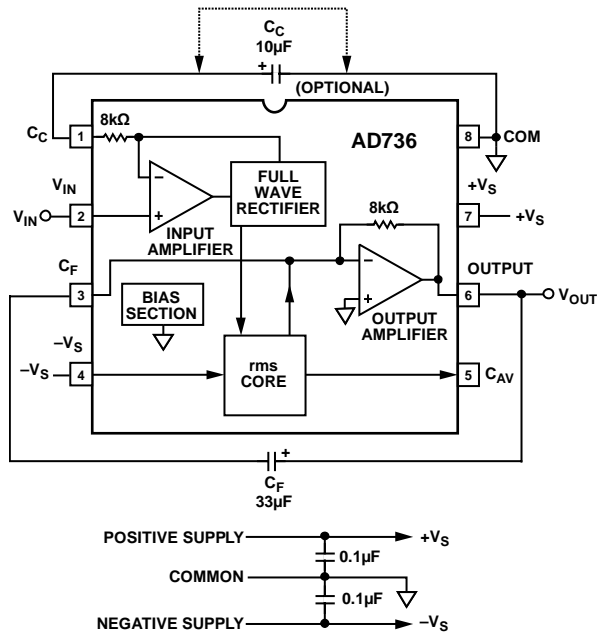

Figure 19. AD736 Average Responding Circuit

DC ERROR, OUTPUT RIPPLE, AND AVERAGING ERROR

Figure 20 shows the typical output waveform of the AD736 with a sine wave input applied. As with all real-world devices, the ideal output of $V_{OUT} = V_{IN}$ is never achieved exactly. Instead, the output contains both a dc and an ac error component.

As shown in Figure 20, the dc error is the difference between the average of the output signal (when all the ripple in the output is removed by external filtering) and the ideal dc output. The dc error component is therefore set solely by the value of the averaging capacitor used. No amount of post filtering (that is, using a very large C_F) allows the output voltage to equal its ideal value. The ac error component, an output ripple, can be easily removed by using a large enough post filtering capacitor, C_F .

In most cases, the combined magnitudes of both the dc and ac error components need to be considered when selecting appropriate values for Capacitor C_{AV} and Capacitor C_F . This combined error, representing the maximum uncertainty of the measurement, is termed the averaging error and is equal to the peak value of the output ripple plus the dc error.

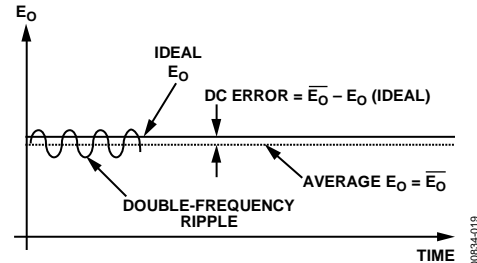

Figure 20. Output Waveform for Sine Wave Input Voltage

As the input frequency increases, both error components decrease rapidly; if the input frequency doubles, the dc error and ripple reduce to one quarter and one half of their original values, respectively, and rapidly become insignificant.

AC MEASUREMENT ACCURACY AND CREST FACTOR

The crest factor of the input waveform is often overlooked when determining the accuracy of an ac measurement. Crest factor is defined as the ratio of the peak signal amplitude to the rms amplitude (crest factor = V_{PEAK}/V_{rms}). Many common waveforms, such as sine and triangle waves, have relatively low crest factors (≤ 2). Other waveforms, such as low duty-cycle pulse trains and SCR waveforms, have high crest factors. These types of waveforms require a long averaging time constant (to average out the long periods between pulses). Figure 8 shows the additional error vs. the crest factor of the AD736 for various values of C_{AV} .

APPLICATIONS

CONNECTING THE INPUT

The inputs of the AD736 resemble an op amp, with noninverting and inverting inputs. The input stages are JFETs accessible at Pin 1 and Pin 2. Designated as the high impedance input, Pin 2 is connected directly to a JFET gate. Pin 1 is the low impedance input because of the scaling resistor connected to the gate of the second JFET. This gate-resistor junction is not externally accessible and is servo-ed to the voltage level of the gate of the first JFET, as in a classic feedback circuit. This action results in the typical 8 kΩ input impedance referred to ground or reference level.

This input structure provides four input configurations as shown in Figure 21, Figure 22, Figure 23, and Figure 24. Figure 21 and Figure 22 show the high impedance configurations, and Figure 23 and Figure 24 show the low impedance connections used to extend the input voltage range.

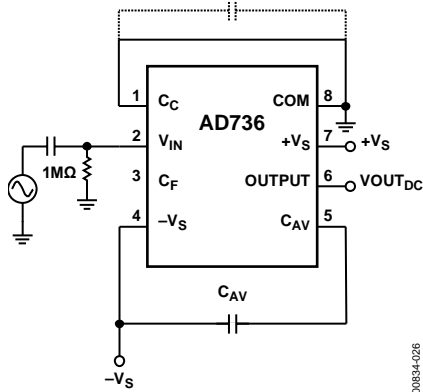

Figure 21. High-Z AC-Coupled Input Connection (Default)

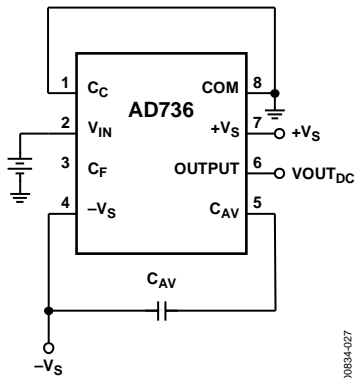

Figure 22. High-Z DC-Coupled Input Connection

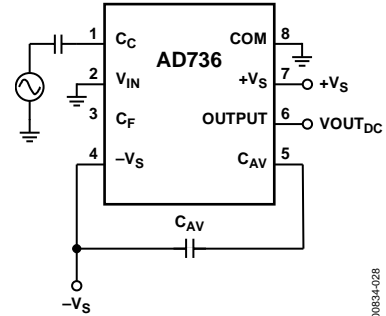

Figure 23. Low-Z AC-Coupled Input Connection

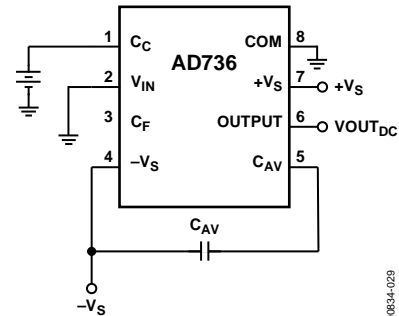

Figure 24. Low-Z DC-Coupled Input Connection

SELECTING PRACTICAL VALUES FOR INPUT COUPLING (C_C), AVERAGING (C_{AV}), AND FILTERING (C_F) CAPACITORS

Table 6 provides practical values of C_{AV} and C_F for several common applications.

The input coupling capacitor, C_C , in conjunction with the 8 k Ω internal input scaling resistor, determine the -3 dB low frequency roll-off. This frequency, F_L , is equal to

$$F_L = \frac{1}{2\pi(8000)(\text{Value of } C_C \text{ in Farads})}$$

Note that at F_L , the amplitude error is approximately -30% (-3 dB) of the reading. To reduce this error to 0.5% of the reading, choose a value of C_C that sets F_L at one-tenth of the lowest frequency to be measured.

In addition, if the input voltage has more than 100 mV of dc offset, then the ac-coupling network shown in Figure 27 should be used in addition to C_C .

Table 6. Capacitor Selection Chart

Application	RMS Input Level	Low Frequency Cutoff (-3 dB)	Max Crest Factor	C_{AV} (μF)	C_F (μF)	Settling Time ¹ to 1%
General-Purpose RMS Computation	0 V to 1 V	20 Hz	5	150	10	360 ms
		200 Hz	5	15	1	36 ms
	0 mV to 200 mV	20 Hz	5	33	10	360 ms
		200 Hz	5	3.3	1	36 ms
General Purpose Average Responding	0 V to 1 V	20 Hz		None	33	1.2 sec
		200 Hz		None	3.3	120 ms
	0 mV to 200 mV	20 Hz		None	33	1.2 sec
		200 Hz		None	3.3	120 ms
SCR Waveform Measurement	0 mV to 200 mV	50 Hz	5	100	33	1.2 sec
		60 Hz	5	82	27	1.0 sec
	0 mV to 100 mV	50 Hz	5	50	33	1.2 sec
		60 Hz	5	47	27	1.0 sec
Audio Applications	0 mV to 200 mV	300 Hz	3	1.5	0.5	18 ms
	0 mV to 100 mV	20 Hz	10	100	68	2.4 sec

¹ Settling time is specified over the stated rms input level with the input signal increasing from zero. Settling times are greater for decreasing amplitude input signals.

ADDITIONAL APPLICATION CONCEPTS

Figure 25 through Figure 28 show four application concepts. Figure 25 shows the high input impedance FET input connected to a multitap attenuator network used in various types of instruments requiring wide ranges of voltages. For a direct network connection, the gate-charge bleeding resistor is not required. The impedance of the FET input is high enough ($10^{12} \Omega$) so that the loading error is negligible. Manufacturers and distributors of the matched precision resistor networks shown in these figures can easily be found on the Web. The voltages shown in the diagrams are the input levels corresponding to 200 mV at each tap. Finally, the

47 k Ω , 1 W resistor and diode pair are a practical input protection scheme for ac line connection measurements.

Figure 26 shows both inputs connected differentially. Figure 27 shows additional components used for offset correction of the output amplifier, and Figure 28 shows connections for single-supply operation such as is the case for handheld devices.

Further information can be found in the [AN-268 Application Note—RMS-to-DC Converters Ease Measurement Tasks](#)—and the [RMS to DC Converter Application Guide](#), both of which can be found on the Analog Devices, Inc., website.

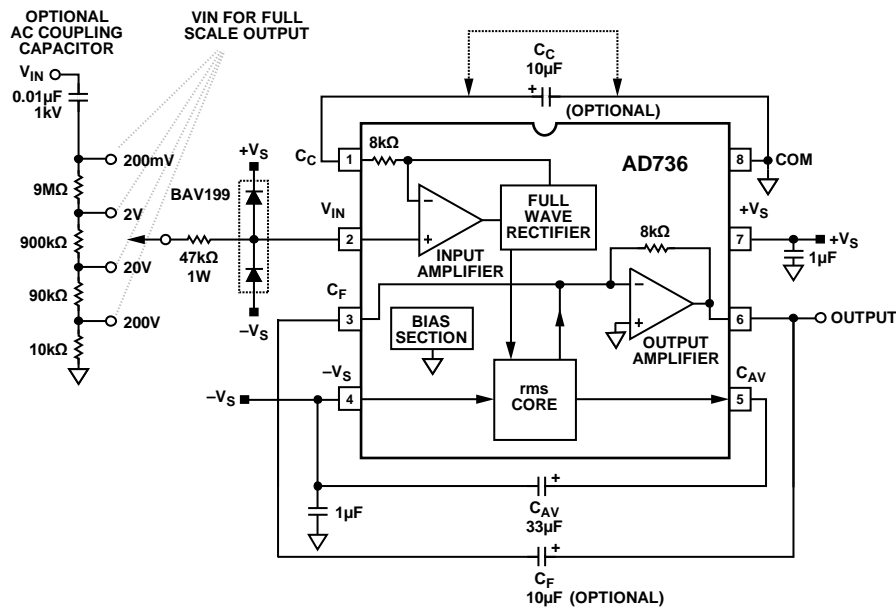

Figure 25. AD736 with a High Impedance Input Attenuator

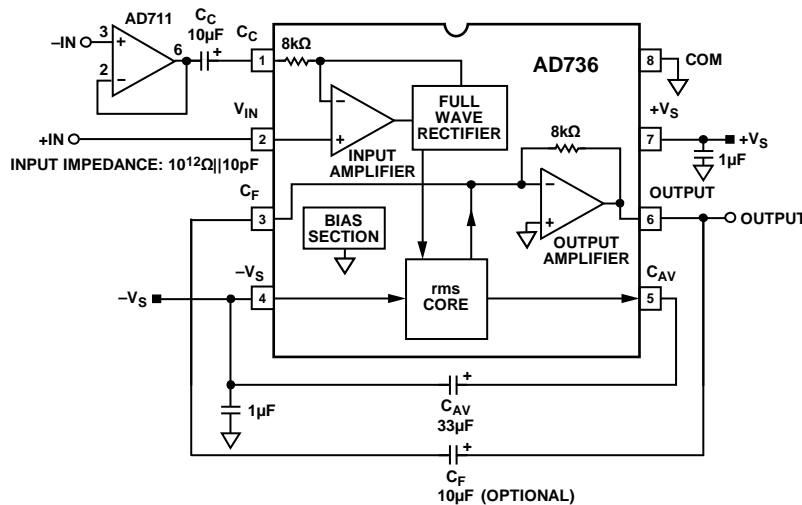

Figure 26. Differential Input Connection

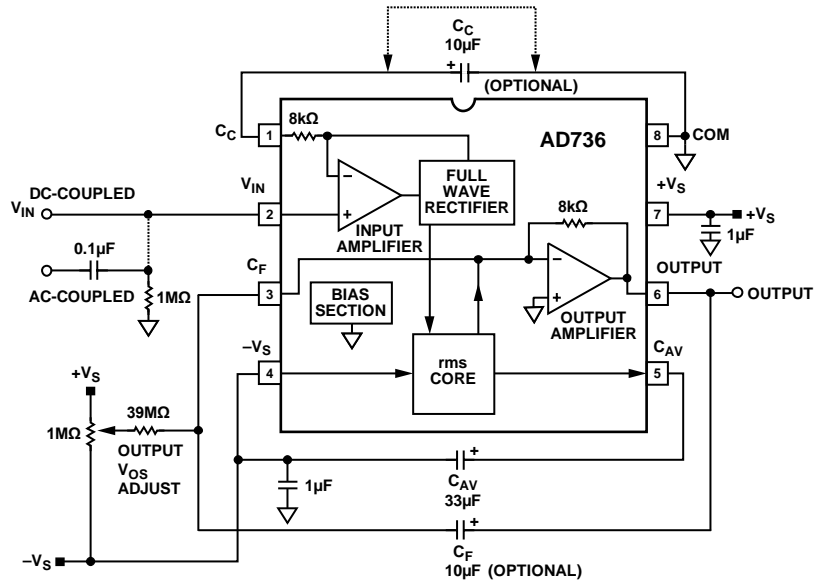

Figure 27. External Output V_{OS} Adjustment

00834-022

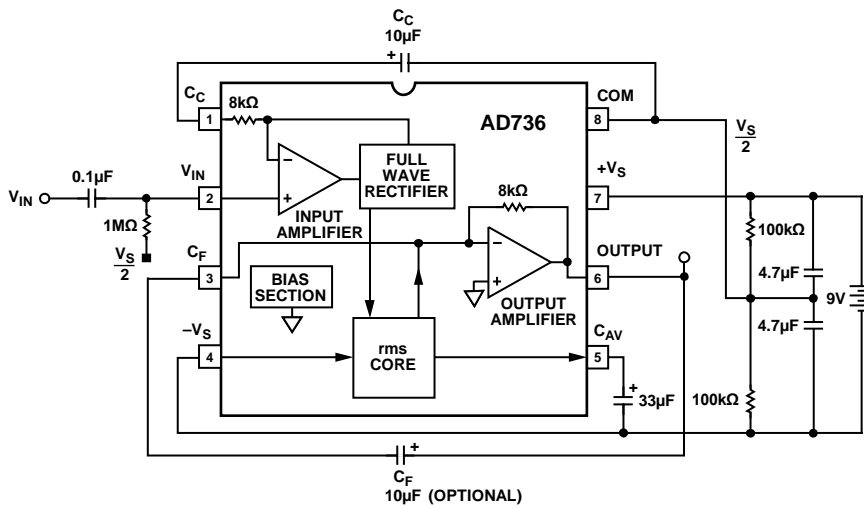

Figure 28. Battery-Powered Option

00834-023

EVALUATION BOARD

An evaluation board, AD736-EVALZ, is available for experimentation or becoming familiar with rms-to-dc converters. Figure 29 is a photograph of the board, and Figure 30 is the top silkscreen showing the component locations. Figure 31, Figure 32, Figure 33, and Figure 34 show the layers of copper, and Figure 35 shows the schematic of the board configured as shipped. The board is designed for multipurpose applications and can be used for the AD737 as well.

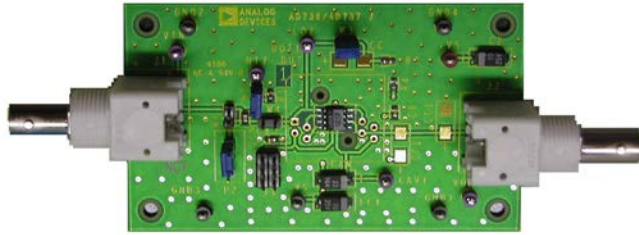

Figure 29. AD736 Evaluation Board

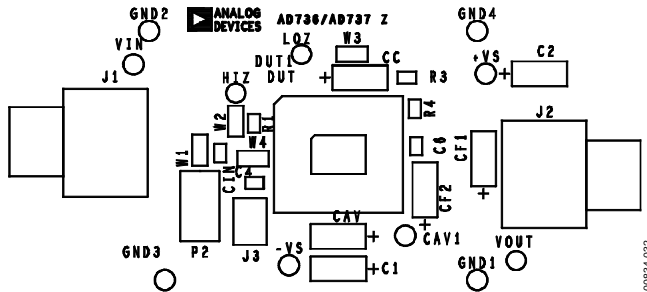

Figure 30. Evaluation Board—Component-Side Silkscreen

As shipped, the board is configured for dual supplies and high impedance input. Optional jumper locations enable low impedance and dc input connections. Using the low impedance input (Pin 1) often enables higher input signals than otherwise possible. A dc connection enables an ac plus dc measurement, but care must be taken so that the opposite polarity input is not dc-coupled to ground.

Figure 35 shows the board schematic with all movable jumpers. The jumper positions in black are default connections; the dotted-outline jumpers are optional connections. The board is tested prior to shipment and only requires a power supply connection and a precision meter to perform measurements.

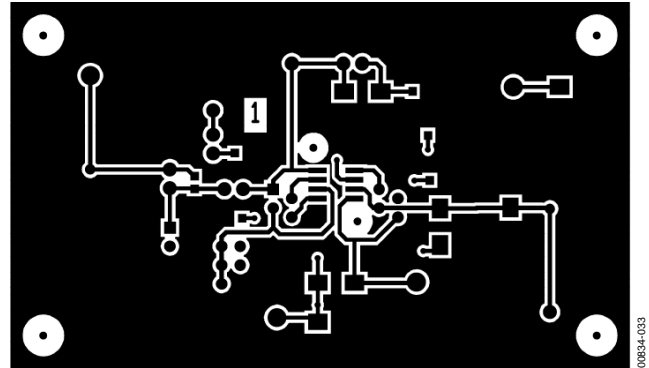

Figure 31. Evaluation Board—Component-Side Copper

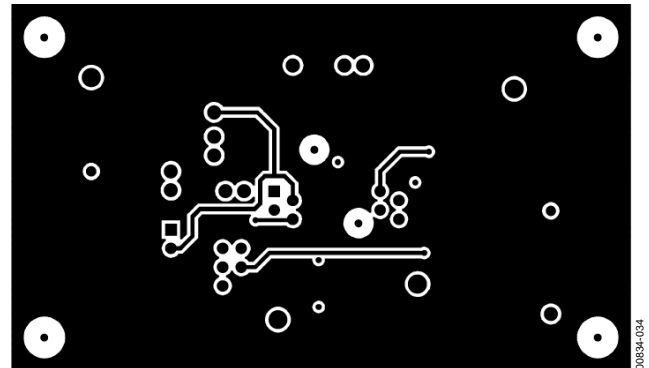

Figure 32. Evaluation Board—Secondary-Side Copper

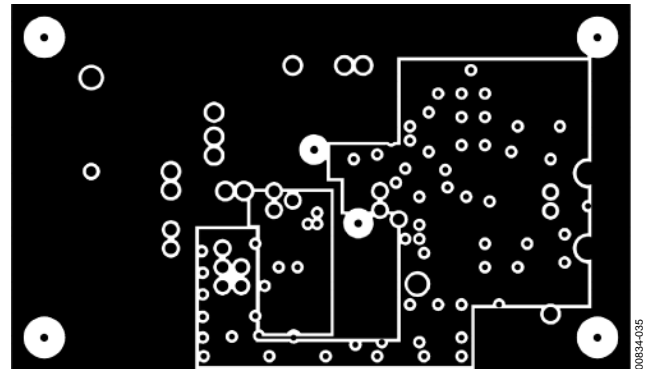

Figure 33. Evaluation Board—Internal Power Plane

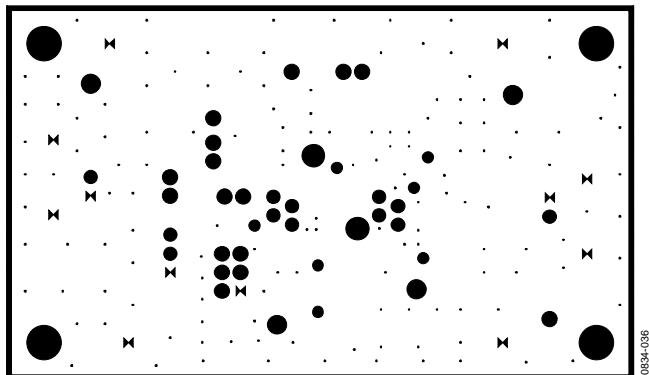

Figure 34. Evaluation Board—Internal Ground Plane

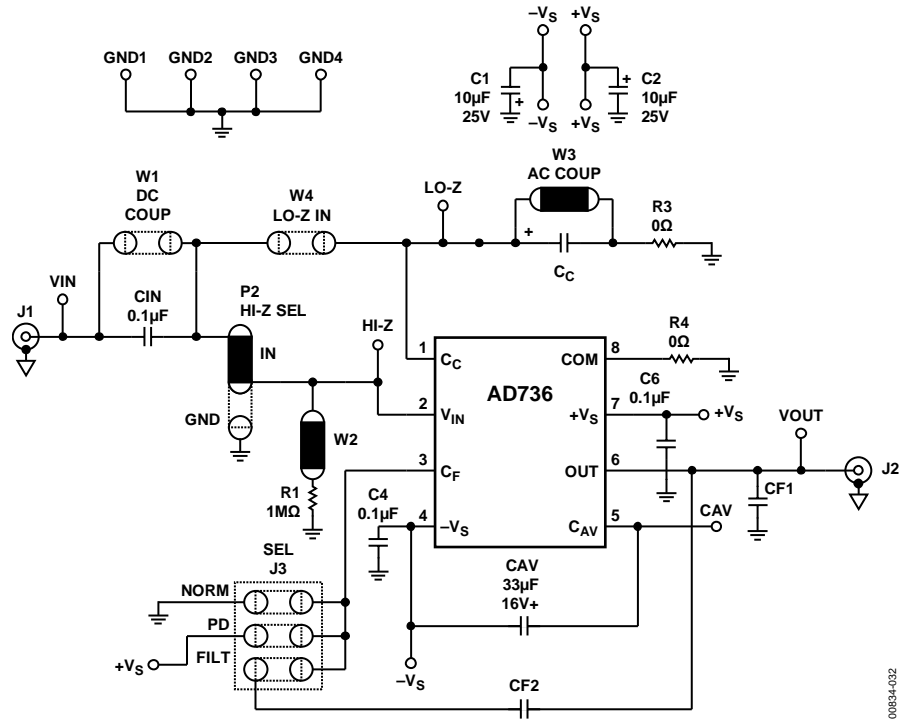
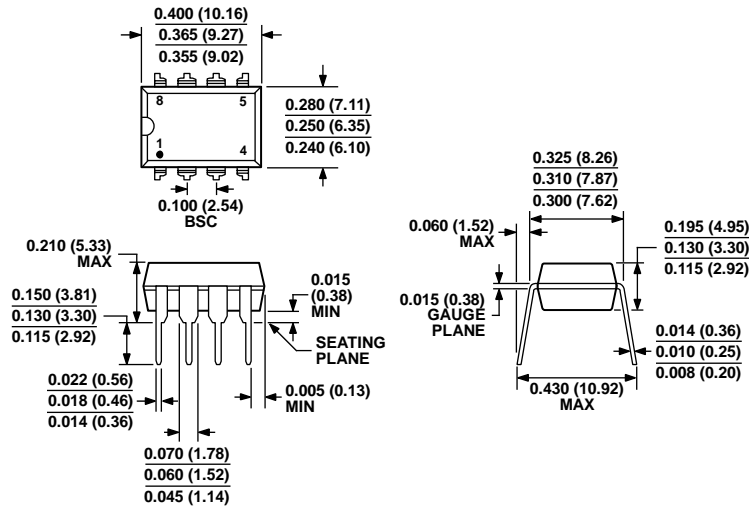

Figure 35. Evaluation Board Schematic

000834-032

OUTLINE DIMENSIONS



COMPLIANT TO JEDEC STANDARDS MS-001
 CONTROLLING DIMENSIONS ARE IN INCHES; MILLIMETER DIMENSIONS
 (IN PARENTHESES) ARE ROUNDED-OFF INCH EQUIVALENTS FOR
 REFERENCE ONLY AND ARE NOT APPROPRIATE FOR USE IN DESIGN.
 CORNER LEADS MAY BE CONFIGURED AS WHOLE OR HALF LEADS.

070606-A

Figure 36. 8-Lead Plastic Dual In-Line Package [PDIP]
 Narrow Body (N-8)
 Dimensions shown in inches and (millimeters)

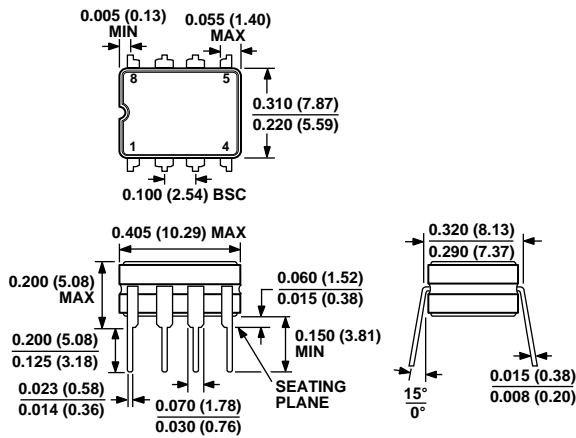

CONTROLLING DIMENSIONS ARE IN INCHES; MILLIMETER DIMENSIONS
 (IN PARENTHESES) ARE ROUNDED-OFF INCH EQUIVALENTS FOR
 REFERENCE ONLY AND ARE NOT APPROPRIATE FOR USE IN DESIGN.

Figure 37. 8-Lead Ceramic Dual In-Line Package [CERDIP]
 (Q-8)
 Dimensions shown in inches and (millimeters)

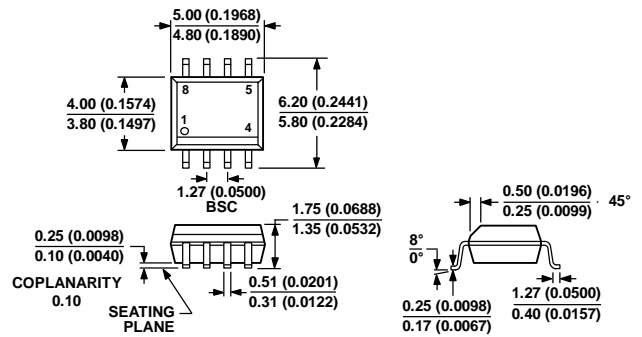

COMPLIANT TO JEDEC STANDARDS MS-012-AA
 CONTROLLING DIMENSIONS ARE IN MILLIMETERS; INCH DIMENSIONS
 (IN PARENTHESES) ARE ROUNDED-OFF MILLIMETER EQUIVALENTS FOR
 REFERENCE ONLY AND ARE NOT APPROPRIATE FOR USE IN DESIGN.

012407-A

Figure 38. 8-Lead Standard Small Outline Package [SOIC_N]
 Narrow Body (R-8)
 Dimensions shown in millimeters and (inches)

ORDERING GUIDE

Model ¹	Temperature Range	Package Description	Package Option
AD736AQ	-40°C to +85°C	8-Lead CERDIP	Q-8
AD736BQ	-40°C to +85°C	8-Lead CERDIP	Q-8
AD736AR-REEL	-40°C to +85°C	8-Lead SOIC_N	R-8
AD736AR-REEL7	-40°C to +85°C	8-Lead SOIC_N	R-8
AD736ARZ	-40°C to +85°C	8-Lead SOIC_N	R-8
AD736ARZ-R7	-40°C to +85°C	8-Lead SOIC_N	R-8
AD736ARZ-RL	-40°C to +85°C	8-Lead SOIC_N	R-8
AD736BR-REEL	-40°C to +85°C	8-Lead SOIC_N	R-8
AD736BR-REEL7	-40°C to +85°C	8-Lead SOIC_N	R-8
AD736BRZ	-40°C to +85°C	8-Lead SOIC_N	R-8
AD736BRZ-R7	-40°C to +85°C	8-Lead SOIC_N	R-8
AD736BRZ-RL	-40°C to +85°C	8-Lead SOIC_N	R-8
AD736JN	0°C to +70°C	8-Lead PDIP	N-8
AD736JNZ	0°C to +70°C	8-Lead PDIP	N-8
AD736KNZ	0°C to +70°C	8-Lead PDIP	N-8
AD736JR	0°C to +70°C	8-Lead SOIC_N	R-8
AD736JR-REEL	0°C to +70°C	8-Lead SOIC_N	R-8
AD736JR-REEL7	0°C to +70°C	8-Lead SOIC_N	R-8
AD736JRZ	0°C to +70°C	8-Lead SOIC_N	R-8
AD736JRZ-RL	0°C to +70°C	8-Lead SOIC_N	R-8
AD736JRZ-R7	0°C to +70°C	8-Lead SOIC_N	R-8
AD736KRZ	0°C to +70°C	8-Lead SOIC_N	R-8
AD736KRZ-RL	0°C to +70°C	8-Lead SOIC_N	R-8
AD736KRZ-R7	0°C to +70°C	8-Lead SOIC_N	R-8
AD736-EVALZ		Evaluation Board	

¹ Z = RoHS Compliant Part.