

PROJ. NO.
SEE NOTES

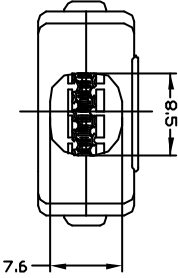
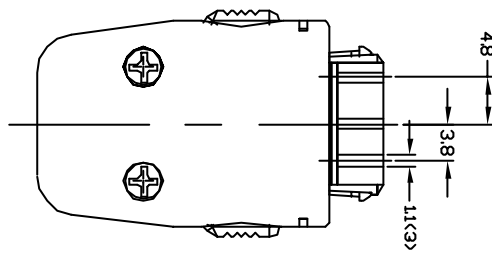
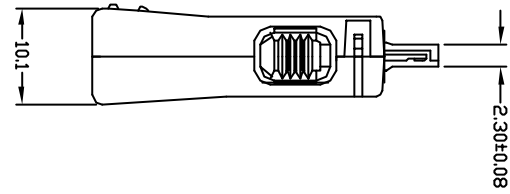
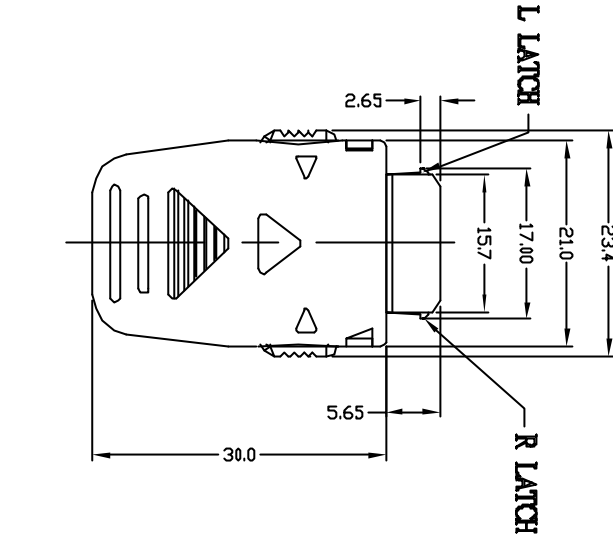
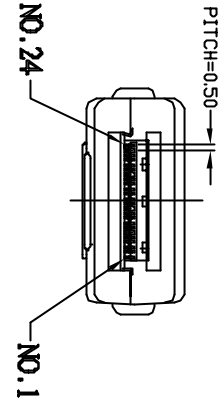

NOTES:

1. MATERIAL: ① BOTT COVER (BLACK ABS).

- ② TOP COVER (BLACK ABS).
- ③ LATCH (STAINLESS STEEL).
- ④ BUTTOM (BLACK ABS).
- ⑤ HOUSING (BLACK NYLON).
- ⑥ SCREW
- ⑦ CONTACT(PHOSPHOR BRONZE T=0.20).

2. ELECTRICAL SPECIFICATION:

- 2.1 Rated current : 0.5A.
- 2.2 Rated Voltage : 150V AC for 1 minute.
- 2.3 Insulation resistance: Min.1000MΩ/500VDC.
- 2.4 Contact resistance: Max.110mΩ.

3. Environmental characteristics:

- 3.1 Operating temperature: -35°C~+85°C.
- 3.2 Storage temperature: -25°C~+55°C.

4. PART NO.: 10032076-X024

*CODE/GOLD PLATING

- A: GOLD FLASH
- D: GOLD 15U"
- M: GOLD 3U"

5. OTHERS: ① PRODUCT SPECIFICATION: GS-12-257.

② PACKAGING SPECIFICATION: GS-14-8B4.

mat'l. code	tolerances unless otherwise specified	CUSTOMER COPY	title
ldr	ecn no	dr	date
A	103-0508 J/C	12/12/03	
	linear	.XX ±.25	
	angles	0° ±2°	
	dr	JASON HSU	9/30/03
	engr	JASON HSU	9/30/03
	chr	STERLING LIN	9/30/03
	appd	JAMES HSU	9/30/03
sheet	revision	A	
Index	sheet	1	
	projection	MM	
	scale	N/A	
	product family	MOBILE	
	size/dwg no	10032076	
	code		
	sheet	1 of 1	

FCI
www.fciconnect.com

MOBILE I/O CONNECTOR
24P CABLE-END ASSEMBLY

ACAN

code code
22526