

Monolithic Digital-To-Analog Converter 12-Bit, 20Mps

The TDC1012 is a TTL compatible, 12-bit monolithic D/A converter capable of converting digital data into an analog current or voltage at data rates in excess of 20 Mega-samples-per second (Mps).

The analog performance has been optimized for dynamic performance, with very low glitch energy. The dual outputs are able to drive 50Ω load with 1 Volt output levels while keeping a spurious-free-dynamic range greater than 70dB.

Data registers are incorporated on the TDC1012. This eliminates the temporal data skew encountered with external registers and latches and minimizes the glitches that can adversely affect performance in many applications.

Features

- 12-Bit Resolution
- 20 Mps Data Rate
- TTL Inputs
- Very Low Glitch With No Track And Hold Circuit Needed
- Dual +4dBm (1V Into 50Ω) Outputs Make Output Amplifiers Unnecessary In Many Applications
- 70dB Typical Spurious-Free Dynamic Range
- Available Compliant To MIL-STD-883

Applications

- Direct Digital RF Signal Generation
- Test Signal Generation
- Arbitrary Waveform Synthesis
- Broadcast And Studio Video
- High-Resolution A/D Converters

B

Interface Circuit

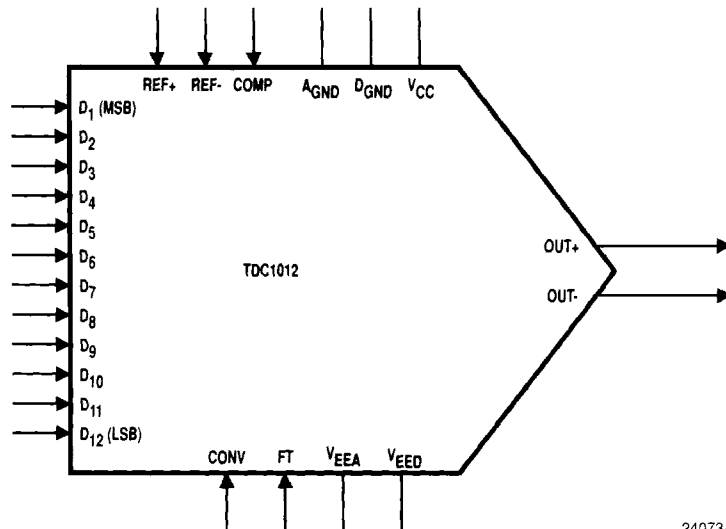

24073A

23

Functional Block Diagram

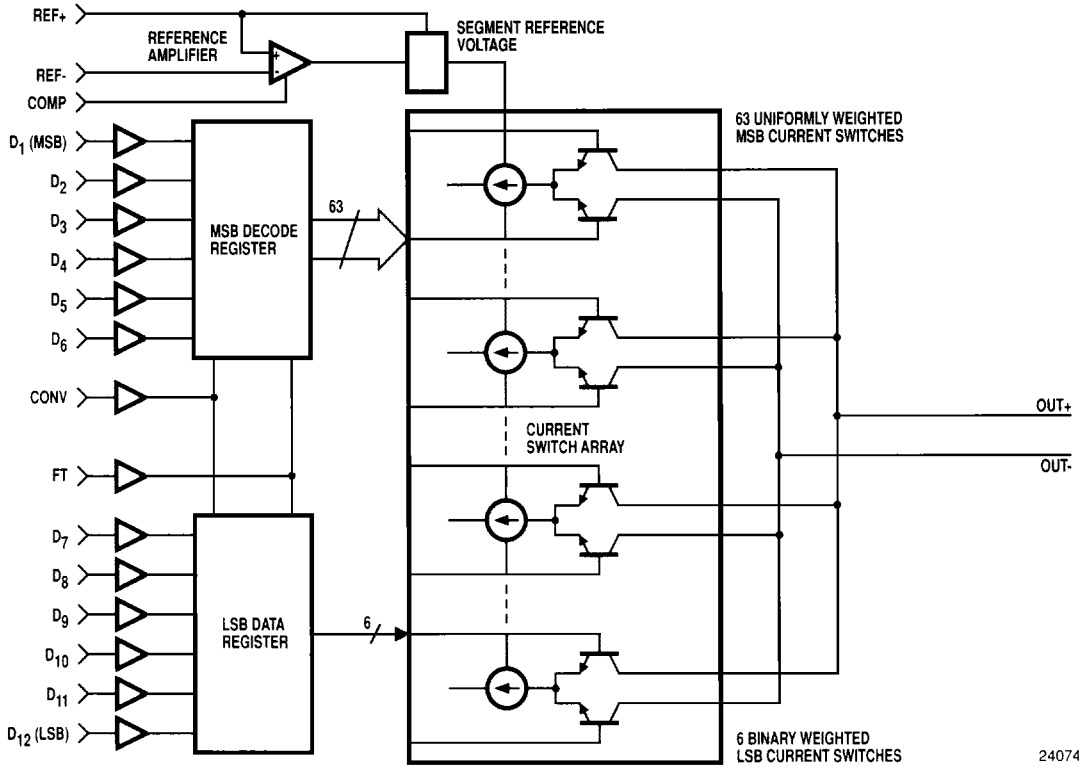

24074A

Pin Assignments

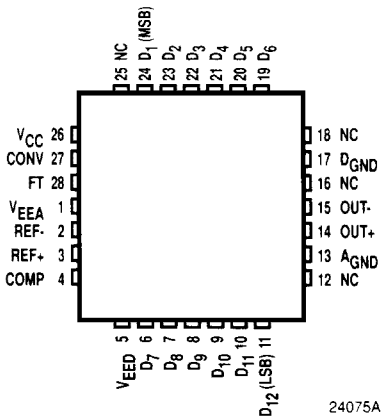

24075A

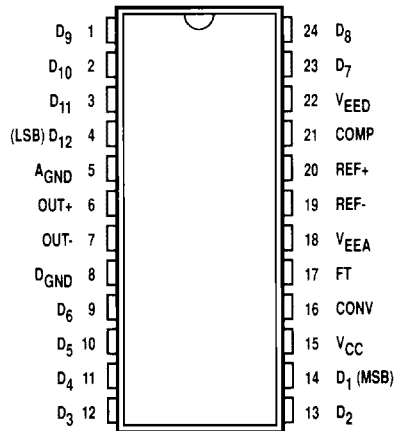

24076A

28 Contact Chip Carrier-C3 Package
28 Leaded Plastic Chip Carrier-R3 Package

24 Pin Hermetic Ceramic DIP-J7 Package
24 Pin Plastic DIP-N7 Package

Functional Description

General Information

The TDC1012 consists of five major circuit sections: the LSB data register, the MSB decode block, the decoded MSB register, the current switch array, and the reference amplifier. All data bits are registered just before the current switches to minimize the temporal skew that would generate glitches.

There are three major D/A architectures: segmented, weighted current sources, and R-2R. In segmented converters there is one current source for each possible output level. The current sources are equally weighted and for an input code of N, N current sources are turned on. An N bit segmented D/A has $2^N - 1$ current sources. A weighted current source D/A has one current source for each input bit, and a binary weighting for the current sources. In an R-2R D/A, there is one current source per bit and a resistor network which scales the current sources to have a binary weighting. When transitioning from a code of 011111111111 to 100000000000, both the R-2R D/A and Binary weighted D/A are turning some current sources on while turning others off. If the timing is not perfect, there is a moment where too many current sources are either on or off, resulting in a glitch. In a segmented architecture, 2047 of the current sources remain on, and one more is turned on to increment the output - no possibility of a glitch.

The TDC1012 uses an architecture with the 6 MSBs segmented and the 6 LSBs form a R-2R network. The result is a D/A converter which has very low-glitch energy, and a moderate die size.

Power, Grounds

The TDC1012 requires a -5.2V power supply and a +5.0V power supply. The analog (V_{EEA}) and digital (V_{EED}) supply voltages should be decoupled from each other, as shown in the *Typical Interface Circuits*. The V_{CC} pin should be considered a digital power supply. The 0.1 μ F decoupling capacitors should be placed as close as possible to the power pins. The inductors are simple ferrite beads and are neither critical in value nor always required.

Reference

The TDC1012 has two reference inputs: REF+ and REF-. These are the inverting and noninverting inputs of the internal reference amplifier. An externally generated reference voltage is applied to the REF- pin. Current flows into the REF+ pin through an external current setting resistor (R_{REF}). This current is the reference current (I_{REF}) which serves as an internal reference for the current source array. The output current for an input code N from OUT+ is related to I_{REF} through the following relationship:

$$I_{OUT} = N \times \frac{I_{REF}}{64}$$

Where N is the value of the input code

This means that with an I_{REF} that is nominally 625 μ A, the full scale output is 40mA, which will drive a 50 Ω load in parallel with a 50 Ω transmission line (25 Ω total load) with a 1V peak to peak signal. The impedance seen by the REF- and REF+ pins should be approximately equal so the effect of amplifier input bias current is minimized. The TDC1012 has been optimized to operate with a reference current of 625mA. Significantly increasing or decreasing this current may degrade the performance of the device.

The minimum and maximum values for V_{REF} and I_{REF} are listed in the table of *Operating conditions*. The internal reference amplifier is externally compensated to assure stability. To compensate this amplifier, a 0.1 μ F capacitor should be connected between the COMP pin and V_{EEA} . The amplifier has been optimized to minimize the settling time, and as a result should be considered a DC amplifier. Performance of the TDC1012 operating in a multiplying D/A mode is not guaranteed.

Stable, adjustable reference circuits are shown in the *Typical Interface Circuits*, 5, 6 and 7.

Digital Inputs

The data inputs are TTL compatible. The TDC1012 is specified with two sets of setup and hold times. One of these pairs of specifications guarantees the performance of the TDC1012 to specifications listed in the *Minimum* and *Maximum* columns of the *System performance characteristics* table.

B

The second more rigid specification is recommended for applications where lowest possible glitch and highest SFDR are desired. The more stringent t_S and t_H ensure that the data will not be slewing during times critical to the TDC1012, and will minimize the effects of capacitively coupled data feedthrough and optimize SFDR performance.

Another method for reducing the effect of capacitive coupling is to slow down the slew rates of the digital inputs. This has been done in the circuit shown in the *Typical Interface Circuits* by the addition of 50Ω series resistors to the data lines.

Clock and Feedthrough Control

The TDC1012 requires a TTL clock signal (CONV). Data is synchronously entered on the rising edge of CONV. The CONV input is ignored in the Feedthrough (FT = HIGH) mode. The Feedthrough (FT) pin is normally held LOW, where the TDC1012 operates in a clocked mode (the output changes only after a clock rising edge). An internal pull-down resistor is provided, and this pin may be left open for clocked operation.

For certain applications, such as high-precision successive approximation A/D converters, throughput delay may be more important than glitch performance. In these cases, the FT pin may be brought HIGH, which makes the input registers transparent. This allows the analog output to change immediately and asynchronously in response to the digital inputs.

Since skew in the bits of the input word will result in glitches, and will affect settling time, it is recommended that the TDC1012 be operated in clocked mode for most applications.

Analog Outputs

Two simultaneous and complementary analog outputs are provided. Both of these outputs are full-power current sources. By driving the current source outputs into a resistive load, they may be used as voltage outputs. OUT+ provides a 0 to -40mA output current (0 to -1V when terminated in 25Ω) as the input code varies from 0000 0000 0000 to 1111 1111 1111. OUT- varies in a complementary manner from -40 to 0mA (-1 to 0V when terminated with 25Ω) over the same code range. (See the *Input Coding Table*.)

The output current is proportional to the reference current and the input code. The recommended output termination is 25Ω . This can be provided by placing a 50Ω source resistor between the output pin and ground, then driving a terminated 50Ω transmission line. With this load, the output voltage range of the converter is 0 to -1.0V .

If a load is capacitively coupled to the TDC1012, it is recommended that a 25Ω load at DC, as seen by the TDC1012, continue to be maintained. The output voltage should be kept within the output compliance voltage range, V_{OC} , as specified in the *Electrical characteristics table*, or the accuracy may be impaired.

Package Interconnections

Signal Type	Signal Name	Function	Value	J7 & N7 Package Pins	C3 & R3 Package Pins
Power	VCC	Digital Supply Voltage	+5.0V	15	26
	AGND	Analog Ground	0.0V	5	13
	DGND	Digital Ground	0.0V	8	17
	VEEA	Analog Supply Voltage	-5.2V	18	1
	VEED	Digital Supply Voltage	-5.2V	22	5
Reference	REF-	Reference Voltage Input	-1.0V	19	2
	REF+	Reference Current Input	-625 μ A	20	3
	COMP	Compensation Capacitor	0.1 μ F, see text	21	4
Data Inputs	D ₁ (MSB)	Most Significant Bit	TTL	14	24
	D ₂		TTL	13	23
	D ₃		TTL	12	22
	D ₄		TTL	11	21
	D ₅		TTL	10	20
	D ₆		TTL	9	19
	D ₇		TTL	23	6
	D ₈		TTL	24	7
	D ₉		TTL	1	8
	D ₁₀		TTL	2	9
	D ₁₁		TTL	3	10
	D ₁₂ (LSB)	Least Significant Bit	TTL	4	11
Feedthrough	FT	Feedthrough Mode Control	TTL	17	28
Convert	CONV	Convert (Clock) Input	TTL	16	27
Analog Output	OUT+	Analog Output	0 to 40mA	6	14
	OUT-	Analog Output	40 to 0mA	7	15

B

Input Coding Table¹

Input Data MSB LSB	OUT+ (mA)	VOUT+(mV)	OUT- (mA)	VOUT-(mV)
0000 0000 0000	0.000	0.00	40.000	-1000.00
0000 0000 0001	0.009	-0.24	39.990	-999.75
0000 0000 0010	0.019	-0.49	39.980	-999.52
•	•	•	•	•
•	•	•	•	•
•	•	•	•	•
•	•	•	•	•
0111 1111 1111	19.995	-499.88	20.005	-500.12
1000 0000 0000	20.005	-500.12	19.995	-499.88
•	•	•	•	•
•	•	•	•	•
•	•	•	•	•
1111 1111 1101	39.980	-999.52	0.019	-0.49
1111 1111 1110	39.990	-999.75	0.009	-0.24
1111 1111 1111	40.000	-1000.00	0.000	0.0

Note: 1. I_{REF} = 625 μ A, R_{LOAD} = 25 Ω

Figure 1. Timing Diagram

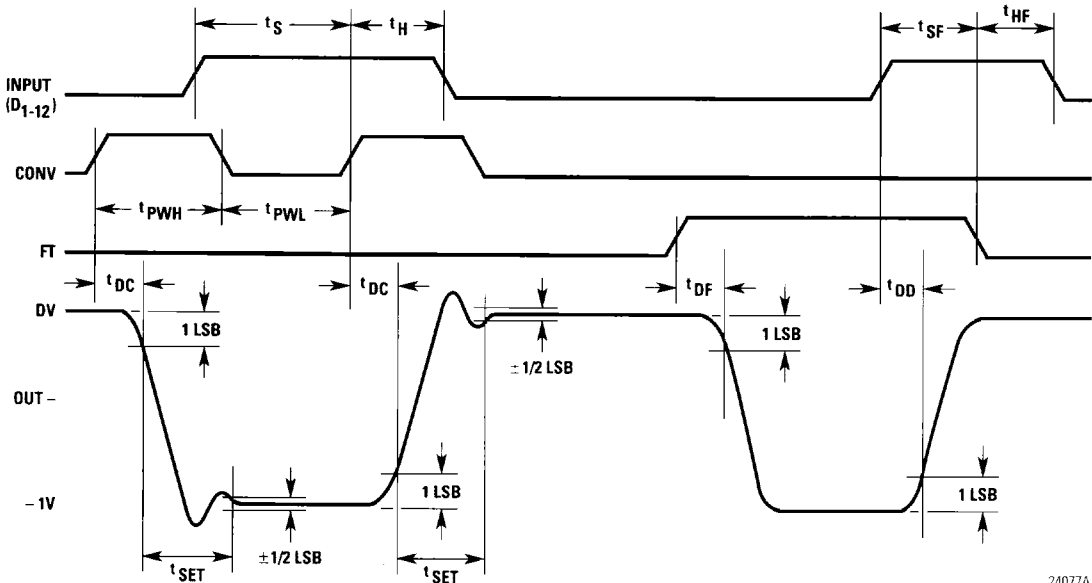

24077A

Figure 2. Equivalent Input Circuits

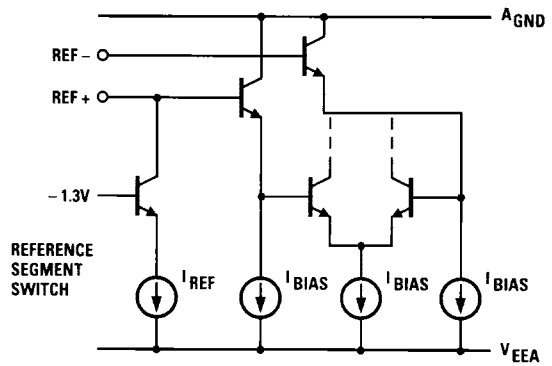
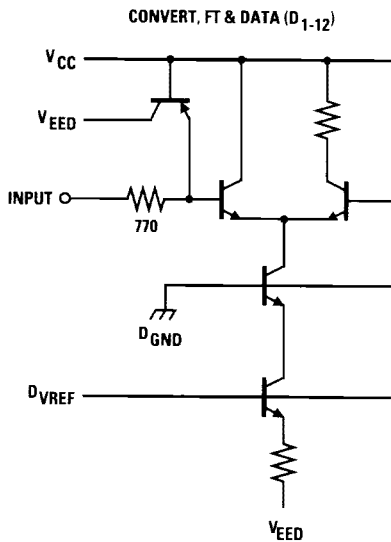

21139A

Figure 3. Equivalent Reference and Output Circuits

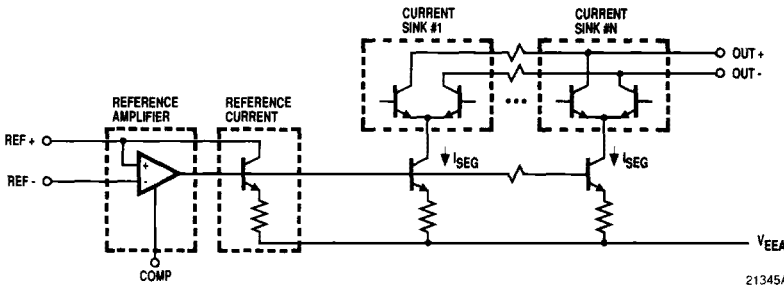
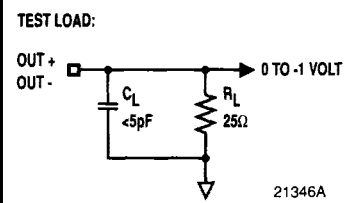

Figure 4. Output Test Load



Absolute maximum ratings (beyond which the device may be damaged)¹

Supply Voltages

VCC (Measured to DGND)	-0.5 to +7.0V
VEEA (Measured to AGND)	-7.0 to +0.5V
VEEA (Measured to VEED)	-50 to +50mV
VEED (Measured to DGND)	-7.0 to +0.5V
AGND (Measured to DGND)	-0.5 to +0.5V

Inputs

CONV, FT, D ₁₋₁₂ (Measured to DGND) ²	VCC +0.5 to -0.5V
CONV, FT, D ₁₋₁₂ Current, Externally Forced ³	+3mA
REF+, REF-, Applied Voltage (Measured to AGND) ³	VEEA to +0V
REF+, REF-, Current, Externally Forced ³	+3mA

Outputs

OUT+, OUT-, Applied Voltage (Measured to AGND) ²	-2.0 to +2.0V
OUT+, OUT-, Current, Externally Forced ³	+50mA
Short-Circuit Duration (Single Output to GND)	unlimited

Temperature

Operating, Ambient	
(Plastic Package)	-20 to +90°C
(Ceramic Package)	-60 to +150°C
Junction	
(Plastic Package)	+140°C
(Ceramic Package)	+200°C
Lead, soldering (10 seconds)	+300°C
Storage	-65 to +150°C

- Note: 1. Absolute maximum ratings are limited values applied individually while other parameters are within specified operating conditions. Functional operation under any of these conditions is NOT implied. Device performance and reliability are guaranteed only if the Operating Conditions are not exceeded.
 2. Applied voltage must be current limited to specified range
 3. Forcing voltage must be limited to specified range. Current is specified as conventional current flowing into the device.

Operating conditions

Parameter	Temperature Range						Units
	Standard			Extended			
	Min	Nom	Max	Min	Nom	Max	
V _{CC}	Positive Supply Voltage (Measured to DGND)						V
V _{EED}	Negative Supply Voltage (Measured to DGND)						V
V _{EAA}	Negative Supply Voltage (Measured to AGND)						V
V _{AGND}	Analog Ground Voltage (Measured to DGND)						V
V _{EAA}	Negative Supply Voltage (Measured to V _{EED})						mV
t _{PWL}	CONV Pulse Width LOW (to Meet Specification)						ns
t _{PWL}	CONV Pulse Width LOW (to Optimize SFDR)						ns
t _{PWH}	CONV Pulse Width HIGH (to Meet Specifications)						ns
t _{PWH}	CONV Pulse Width HIGH (to Optimize SFDR)						ns
t _S	Setup Time, Data to CONV (to Meet Specification)						ns
t _S	Setup Time, Data to CONV (to Optimize SFDR)						ns
t _H	Hold Time (to Meet Specifications)						ns
t _H	Hold Time (to Optimize SFDR)						ns
t _{SF}	Setup Time, Data to FT						ns
t _{HF}	Hold Time, Data to FT						ns
V _{IL}	Input Voltage, Logic LOW						V
V _{IH}	Input Voltage, Logic HIGH						V
V _{REF}	Reference Voltage (REF-)						V
I _{REF}	Reference Current (REF+)						μA
C _C	Compensation Capacitor						μF
T _A	Ambient Temperature, Still Air						°C
T _C	Case Temperature						°C

Notes 1. A common power supply isolated with ferrite bead inductors is recommended for V_{EAA} and V_{EED}. This is shown in the *Typical Interface Circuits*.

Electrical characteristics within specified operating conditions

Parameter	Test Conditions	Temperature Range				Units	
		Standard		Extended			
		Min	Max	Min	Max		
I _{EEA+I_{EE}D}	V _{EEA} =V _{EE} D=Max,static T _A =0 to 70°C		-180			mA	
	T _A =70°C		-150			mA	
	T _C =-55 to 125°C				-200	mA	
	T _C =125°C				-150	mA	
I _{CC}	V _{CC} =Max, Static T _A =0 to 70°C		25			mA	
	T _A =70°C		20			mA	
	T _C =-55 to 125°C				35	mA	
	T _C =125°C				24	mA	
C _{REF}	Reference Input Capacitance		15		15	pF	
C _I	Digital Input Capacitance		15		15	pF	
V _{OC}	Compliance Voltage	-1.2	1.2	-1.2	1.2	V	
R _O	Output Resistance	12		12		kΩ	
C _O	Output Capacitance		45		45	pF	
I _O	Full Scale Output Current	I _{REF} =Nominal	40		40	mA	
I _{IL}	Input Current, Logic LOW	V _{CC} , V _{EE} =Max, V _I =0.4V	-10	50	-10	50	μA
I _{IH}	Input Current, Logic HIGH	V _{CC} , V _{EE} =Max, V _I =2.4V	-10	100	-10	100	μA
I _{IM}	Input Current, Max Input Voltage	V _{CC} , V _{EE} =Max, V _I =V _{CC} Max	-10	100	-10	100	μA
V _{TH}	Logic Input Threshold Voltage, Typical	V _{CC} , V _{EE} =Nom, T _A =25°C	1.25	1.55	1.25	1.55	V



Switching characteristics

Parameter	Test Conditions	Temperature Range						Units	
		Standard			Extended				
		Min	Typ	Max	Min	Typ	Max		
f _D	Maximum Data Rate	V _{EEA} , V _{EE} D, V _{CC} = Min	20	25		20	23		MHz
t _{DC}	Clock to Output Delay	V _{EEA} , V _{EE} D, V _{CC} = Min, FT = LOW			17			20	ns
t _{DD}	Data to Output Delay	V _{EEA} , V _{EE} D, V _{CC} = Min, FT = HIGH			35			40	ns
t _{DF}	FT to Output Delay	V _{EEA} , V _{EE} D, V _{CC} = Min			35			40	ns
t _R	Risetime	90% to 10% of FSR, FT = LOW			4			4	ns
t _F	Falltime	10% to 90% of FSR, FT = LOW			4			4	ns
t _{SET}	Settling Time, Voltage	FT = LOW, Full-Scale Voltage Transition on I _O UT to ±0.0188% FSR		20	30		20	35	ns

System performance characteristics

Parameter	Test Conditions	Temperature Range						Units
		Standard			Extended			
		Min	Typ	Max	Min	Typ	Max	
E _{LD} Differential Linearity Error	VEEA, VEED, VCC, IREF= Nom ¹ TDC1012XXY3			±0.012			±0.012	%
	TDC1012XXY2			±0.024			±0.024	%
	TDC1012XXY1			±0.048			±0.048	%
E _{LI} Integral Linearity Error	VEEA, VEED, VCC, IREF= Nom ¹ TDC1012XXY3			±0.024			±0.024	%
	TDC1012XXY2			±0.048			±0.048	%
	TDC1012XXY1			±0.048			±0.048	%
V _{OS} REF+ to REF- Offset Voltage		-10		+10	-10		+10	mV
I _B REF- Input Bias Current				5			10	µA
E _G Absolute Gain Error	VEEA, VEED, VCC, IREF= Nom	-5		5	-5		5	%
I _{OF} Output Offset Current	VEEA, VEED, VCC= Min, D ₁₋₁₂ =LOW	-5		+5	-5		+5	µA
PSRR Power Supply Rejection Ratio	VEEA, VEED, VCC, IREF= Nom ²			-50			-48	dB
PSS Power Supply Sensitivity	VCC, VEEA, VEED=4%, IREF=Nom			-140			-140	µA/V
G _A Peak Glitch Area			25	45		25	45	pV-sec
SFDR Spurious Free Dynamic Range	IREF=Nom, 20Msps, 10MHz bandwidth F _{out} =6MHz	60			60			dBc
	F _{out} =5MHz		70					dBc
	F _{out} =2MHz		75					dBc
	F _{out} =1MHz		78					dBc

- Notes: 1. OUT- connected to AGND, OUT- driving virtual ground
 2. 120Hz, 600mV p-p ripple on V_{EE} and V_{CC}.

Typical Performance Curves (Typical Settling Time Characteristics)

A. Full-Scale Output Transition, Rising Edge

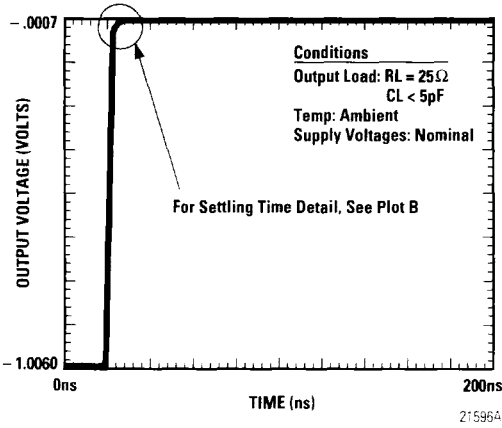

B. Settling Time, Full-Scale Output, Rising Edge

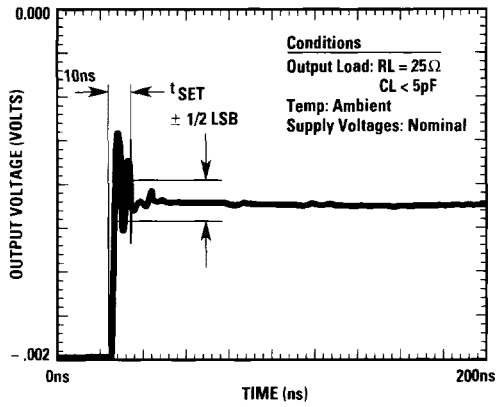

B

C. Full-Scale Output Transition, Falling Edge

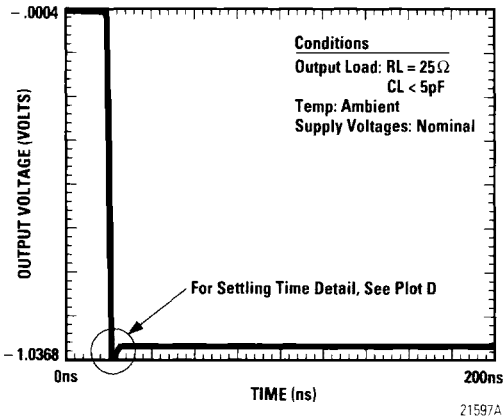

D. Settling Time, Full-Scale Output, Falling Edge

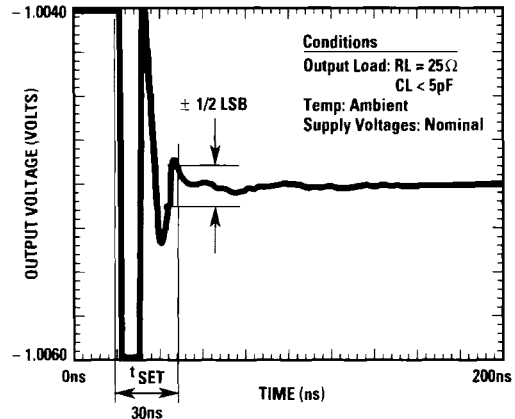

E. Typical Settling Time vs. Settling Accuracy

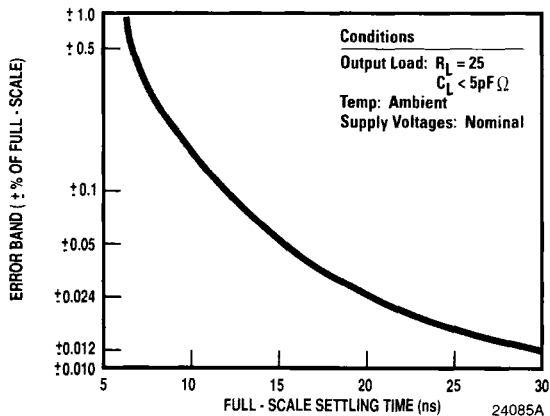

F. Typical Supply Current vs. Temperature

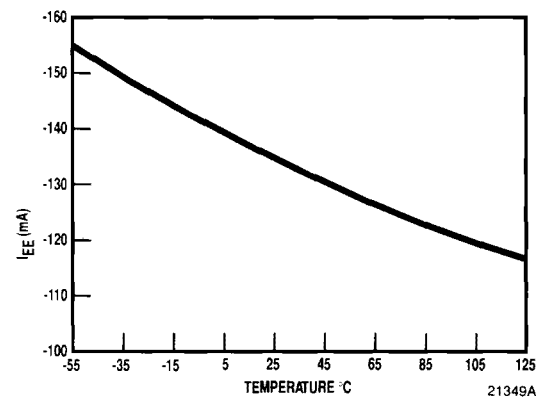

G. Typical Output Spectrum 20Mps 1MHz FOUT

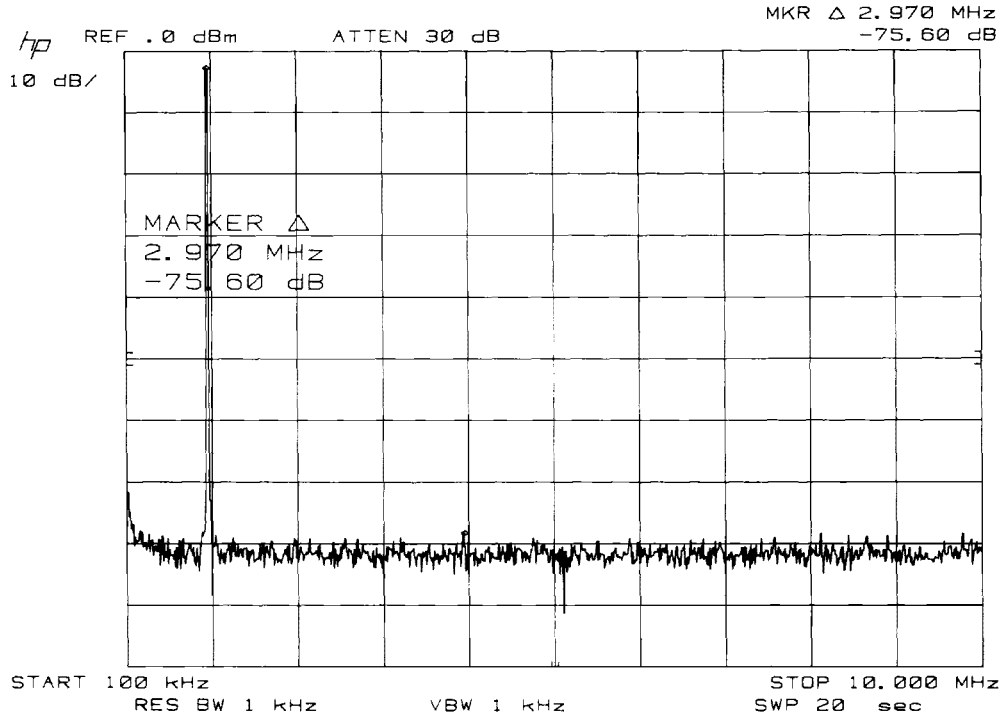

Applications Discussion

The TDC1012 is a high performance D/A converter. To get the best possible performance requires careful attention to the details of circuit design and layout.

Layout

The layout of grounds in any system is an important design consideration. Separate analog and digital grounds are provided at the TDC1012. All ground pins should be connected to a common low-noise, low-impedance groundplane. This groundplane should be common for the TDC1012 and all of its immediate interface circuitry, which includes all of the reference circuitry, the output load circuitry, and all of the power supply decoupling components.

The digital driving logic should use a separate system ground, and this ground should be connected to the analog groundplane in only one place. The analog and digital grounds may be connected in other ways if required by the user's system grounding plan, however, the voltage

differential between the AGND and DGND pins must be held to within ± 0.1 Volts.

The high slew-rates of digital data make capacitive coupling with the D/A output a potential problem. Since the digital signals contain high-frequency harmonics of the clock, as well as the signal that is being provided to the TDC1012, the result of data feedthrough often looks like harmonic distortion which degrades the Spurious-Free-Dynamic-Range (SFDR) performance of the D/A. Capacitive coupling can be minimized by keeping digital lines physically away from the analog output and reference. Another technique that can reduce capacitive data coupling is to use low slew rate digital drive circuits or slowing the driving edges with series resistors.

Direct Digital Synthesis Applications

For most synthesis applications, optimum signal purity is obtained with the use of a balun (a simple RF transformer made by wrapping a few turns of wire around a ferrite core) as shown in *Figure 5*. This configuration has the benefit of canceling common mode distortion. An output

amplifier is not recommended because any amplifier will add distortion, which is likely to be much greater than that present from the outputs of the TDC1012.

The strict adherence to at least the minimum input data setup and hold times is important for the realization of the optimal performance. Spur levels may decrease as setup and hold times are increased. It is possible to achieve even higher performance in some instances by carefully "tuning" the input data setup and hold times (slightly delaying or advancing the CONV signal in relation to the data) provided to the TDC1012. The *Operating conditions* table has two sets of data for t_S and t_H , one which guarantees performance of the device in most applications, and one, more conservative specification, which has been found to be optimal for DDS applications.

The actual digital-data waveform which represents a sinewave contains strong harmonics of that fundamental frequency. This can be seen by connecting a digital data line to the input of a spectrum analyzer. Data feedthrough to the analog output of a system due to improper board layout or system shielding and grounding will appear as additional harmonic distortion, adversely affecting SFDR.

Harmonic distortion may improve even further with reduced AC termination impedance values, at the expense of lowered output voltage. This is achieved by a balun used as an impedance transformer as shown in *Figure 5*.

The purity of the output of the TDC1012 is greater than that which can be measured by many spectrum analyzers. The spectral plots shown in this data sheet were generated with an HP8568B, which has a noise floor just below that of the TDC1012. When making spectral

measurements it is important to remember that the TDC1012 output power is +4dBm, which is greater power than many analyzers are equipped to handle without adding distortion of their own. Accordingly, it may be necessary to introduce an attenuator to the input of the spectrum analyzer.

The CONV signal provided to the TDC1012 must be as free from clock jitter as possible. Clock jitter is the random cycle-to-cycle variation in clock period. CONV clock jitter will effectively appear at the output as phase noise. A value of 10ps or less for clock jitter is recommended for the highest performance applications. Ordinary crystal oscillators are satisfactory. High-performance synthesizers, such as the HP8662, used to trigger a precision pulse generator, are also satisfactory.

The TMC2340 direct digital synthesizer is ideal for generating a digital sinusoid for the D/A converter. The TMC2340 automatically generates a carrier frequency which may then be digitally phase, frequency or amplitude modulated. Two outputs are provided which are 90° out of phase (quadrature outputs). For more information on direct digital synthesis, and other applications of the TDC1012, please see application note *TP46* and *AB-8* from TRW LSI Products.

Bipolar Output

See *Figure 6* for a suggested circuit for achieving a bipolar output voltage range. Optimum DC linearity is obtained by using a differential output, either with a balun or an operational amplifier in the differential mode. If it is desired that the TDC1012 be operated in a single-ended fashion, the unused output should be connected directly to ground as is shown in *Figure 7*.

B

Figure 5. Typical Interface Circuit with Balun Output

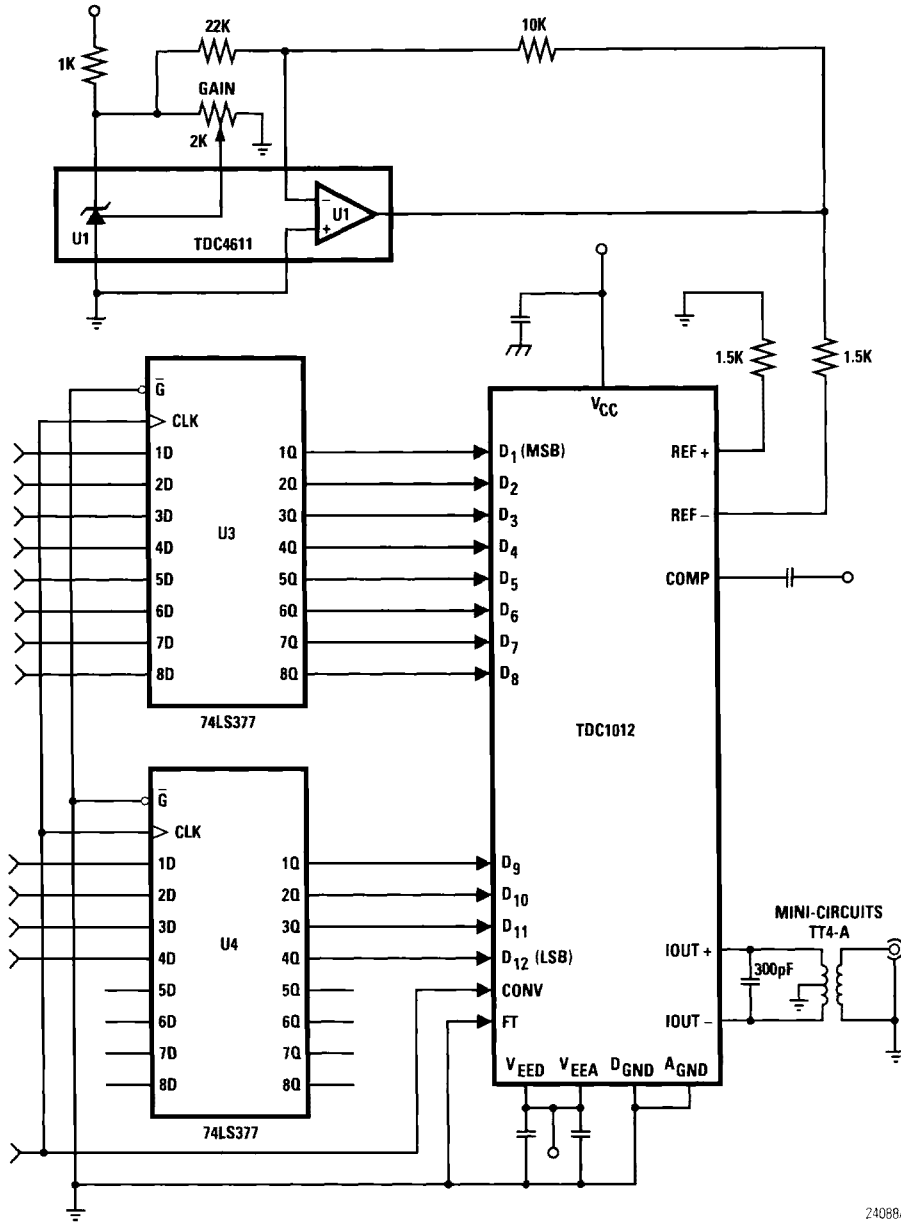

24088A

Figure 6. Typical Interface Circuit with Differential Amplifier Output

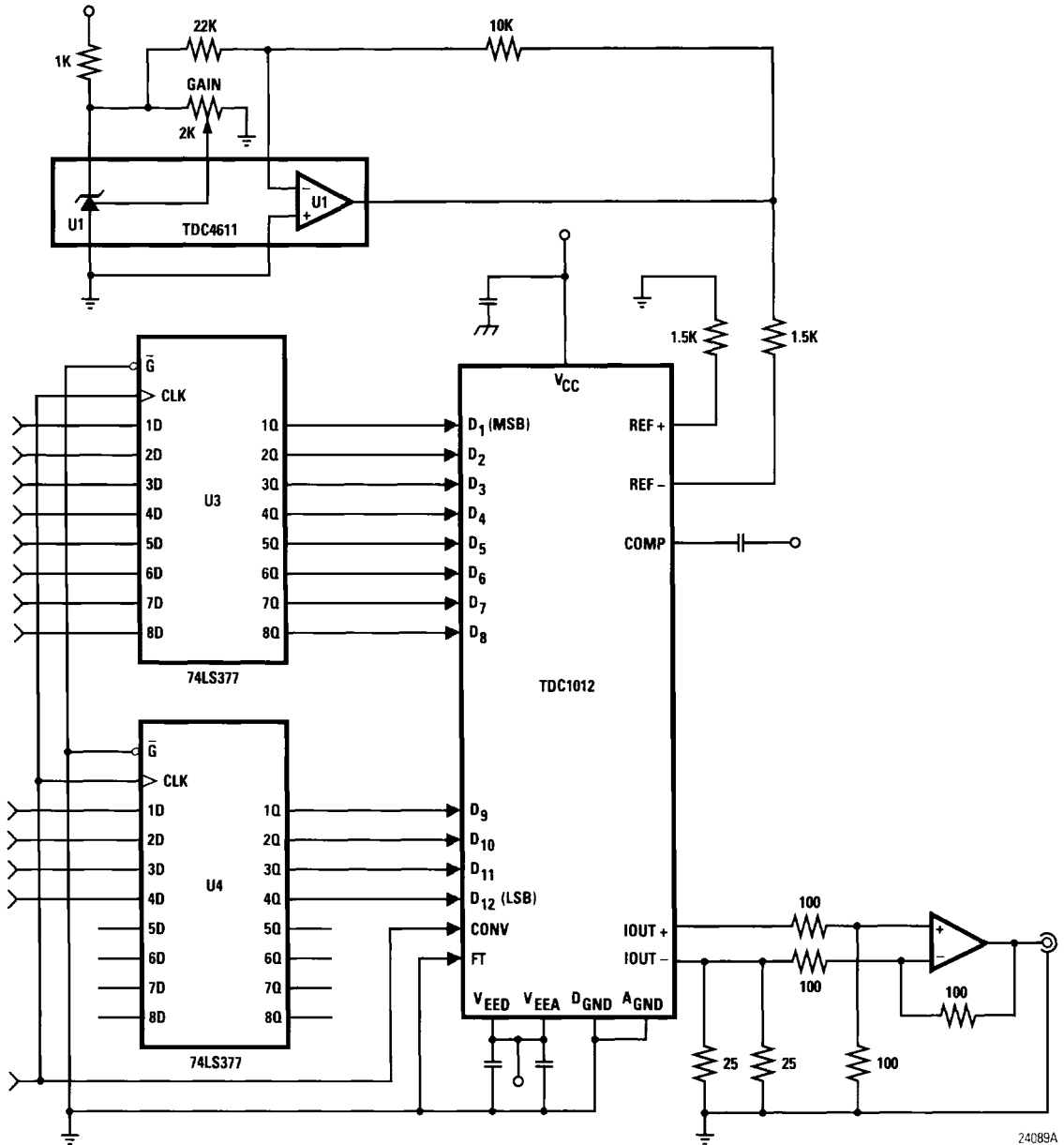

B

24089A

Figure 7. Typical Interface Circuit with Resistive Load Output

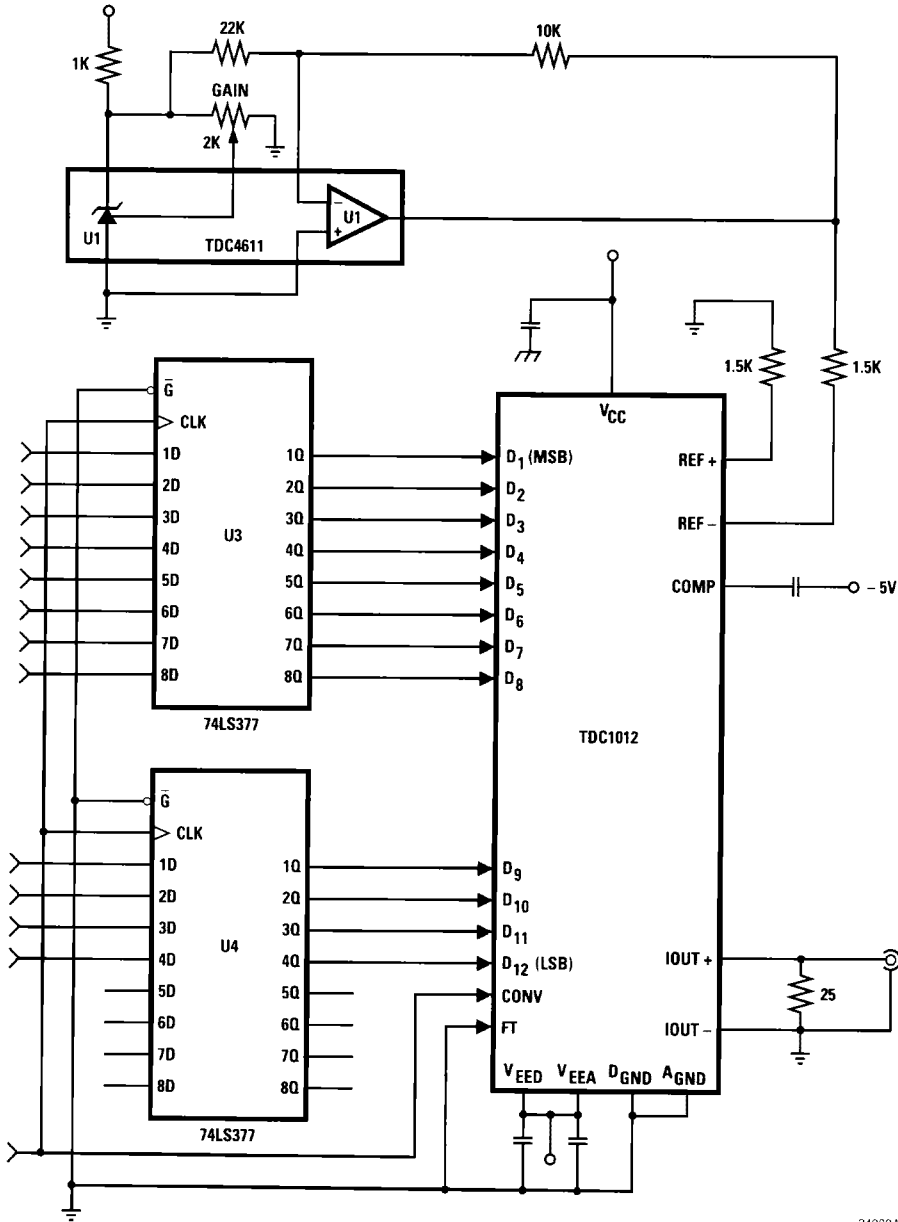

24090A

Ordering Information

Product Number	Temperature Range	Screening	Package	Package Marking
TDC1012N7CX	T _A =0°C to 70°C	Commercial	Plastic DIP	1012N7C-X
TDC1012J7CX	T _A =0°C to 70°C	Commercial	Ceramic DIP	1012J7C-X
TDC1012J7VX	T _C =-55°C to 125°C	MIL-STD-883	Ceramic DIP	1012J7V-X
TDC1012R3CX	T _A =0°C to 70°C	Commercial	Plastic Chip Carrier	1012R3C-X
TDC1012C3VX	T _C =-55°C to 125°C	MIL-STD-883	Ceramic Chip Carrier	1012C3V-X

Linearity Grade (X)		None	1	2	3
E _{LD}	Linearity Error, Differential	±0.096% (4 LSB)	±0.048% (2 LSB)	±0.024% (1 LSB)	±0.012% (1/2 LSB)
E _{LI}	Linearity Error, Integral	±0.096% (4 LSB)	±0.048% (2 LSB)	±0.048% (2 LSB)	±0.024% (1 LSB)



All parameters contained in this specification are guaranteed by design, characterization, sample testing or 100% testing as appropriate. TRW reserves the right to change products and specifications without notice. This information does not convey any license under patent rights of TRW Inc. or others.

Life Support Policy

TRW LSI Products Inc. components are not designed for use in life support applications, wherein a failure or malfunction of the component can reasonably be expected to result in personal injury. The user of TRW LSI Products Inc. components in life support applications assumes all risk of such use and indemnifies TRW LSI Products Inc. against all damages.

I_{REF} = 625A, R_{LOAD} = 25Ω Absolute maximum ratings are limiting values applied individually while other parameters are within specified operating conditions. Functional operation under any of these conditions is NOT implied. Device performance and reliability are guaranteed only if the Operating Conditions are not exceeded. Applied voltage must be current limited to specified range. Forcing Voltage must be limited to specified range. Current is specified as conventional current flowing into the device.

