

Features

- STM1404 supports FIPS-140 security level 4
 - Four high-impedance physical tamper inputs
 - Over/Under operating voltage detector
 - Security alarm ($\overline{\text{SAL}}$) on tamper detection
 - Over/Under operating temperature detector
 - Over/Under temperature thresholds are customer-selectable and factory-programmed
- Supervisory functions
 - Automatic battery switchover
 - $\overline{\text{RST}}$ output (open drain)
 - Manual (push-button) reset input ($\overline{\text{MR}}$)
 - Power-fail comparator (PFI/ $\overline{\text{PFO}}$)
- $\overline{\text{Vccsw}}$ (V_{CC} switch output)
 - Low when switched to V_{CC}
 - High when switched to V_{BAT} (BATT ON indicator)
- Battery low voltage detector (power-up)

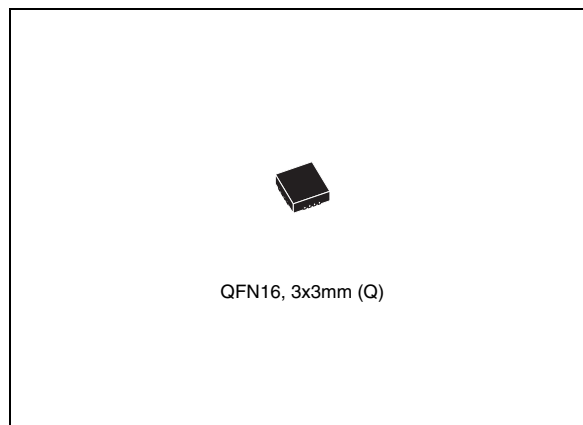

- Optional V_{REF} (1.237V)
 - (Available for STM1404A only)
- Low battery supply current (5.3 μA Typ)
- Secure low profile 16-pin, 3x3mm, QFN package
- RoHS compliance
 - Lead-free components compliant with the RoHS directive

Table 1. Device options

	Supervisory functions ⁽¹⁾	Physical tamper inputs	Over/under voltage alarms	Over/under temperature alarms	V_{REF} (1.237V) option	V_{OUT} status, during alarm	$\overline{\text{Vccsw}}$ status, during alarm
STM1404A	✓	✓	✓	✓	✓	ON	Normal mode ⁽²⁾
STM1404B ⁽³⁾	✓	✓	✓	✓	Note ⁽⁴⁾	High-Z	High
STM1404C	✓	✓	✓	✓	Note ⁽⁴⁾	Ground	High

1. $\overline{\text{SAL}}$, $\overline{\text{RST}}$, $\overline{\text{PFO}}$, and $\overline{\text{BLD}}$ are open drain.

2. Normal mode: low when V_{OUT} is internally switched to V_{CC} and high when V_{OUT} is internally switched to battery.

3. Contact local ST sales office for availability.

4. Pin 9 is the V_{REF} pin for STM1404A. It is the V_{TPU} pin for STM1404B/C.

Contents

Summary description	6
V_{OUT} pin modes	6
STM1404A	6
STM1404B	6
STM1404C	6
Pin descriptions	12
SAL, Security alarm output (open drain)	12
TP ₁ , TP ₃	12
TP ₂ , TP ₄	12
V _{CCSW} , V _{CC} switch output	12
BLD, V _{BAT} low voltage detect output (open drain)	13
Active-low RST output (open drain)	13
MR, Manual reset input	13
PFO, Power-fail output (open drain)	13
PFI, Power-fail input	13
V _{REF} , Reference voltage output (1.237, typ)	13
V _{OUT}	14
V _{TPU}	14
V _{CC}	14
V _{BAT}	14
V _{SS}	14
Operation	15
Reset input	15
Push-button reset input	15
Back-up battery switchover	15
Applications information	16
Negative-going V _{CC} transients and undershoot	17
Tamper detection	18
Physical	18
Supply voltage	18
Temperature	18

Typical operating characteristics	19
Maximum rating	24
DC and AC parameters	25
Package mechanical data	31
Part numbering	33
Revision history	35

List of tables

Table 1.	Device options	1
Table 2.	Signal names	7
Table 3.	I/O status in battery back-up.	16
Table 4.	Absolute maximum ratings	24
Table 5.	Operating and AC measurement conditions.	25
Table 6.	DC and AC characteristics	26
Table 7.	Physical and environmental tamper detection levels	30
Table 8.	QFN16 – 16-lead, quad, flat package, no lead, 3x3mm body size mechanical data	32
Table 9.	Ordering information scheme (see Figure 31 on page 34 for marking information)	33
Table 10.	Document revision history	35

List of figures

Figure 1.	Logic diagram	7
Figure 2.	QFN16 connections	8
Figure 3.	Block diagram	8
Figure 4.	Hardware hookup	9
Figure 5.	Tamper Pin (TP ₁ or TP ₃) Normally High (NH) external hookup (switch closed)	10
Figure 6.	Tamper Pin (TP ₁ or TP ₃) Normally High (NH) external hookup (switch open)	10
Figure 7.	Tamper Pin (TP ₂ or TP ₄) Normally Low (NL) external hookup (switch closed)	10
Figure 8.	Tamper Pin (TP ₂ or TP ₄) Normally Low (NL) external hookup (switch open)	11
Figure 9.	Power-fail comparator waveform	17
Figure 10.	Supply voltage protection	17
Figure 11.	V _{BAT} -to-V _{OUT} on-resistance vs. temperature	19
Figure 12.	Supply current vs. temperature (no load)	19
Figure 13.	V _{PFI} threshold vs. temperature	20
Figure 14.	Reset comparator propagation delay vs. temperature	20
Figure 15.	Power-up t _{rec} vs. temperature	20
Figure 16.	Normalized reset threshold vs. temperature	20
Figure 17.	PFI to PFO propagation delay vs. temperature	21
Figure 18.	RST output voltage vs. supply voltage	21
Figure 19.	RST response time (assertion)	21
Figure 20.	Power-fail comparator response time (assertion)	22
Figure 21.	Power-fail comparator response time (de-assertion)	22
Figure 22.	V _{CC} to reset propagation delay vs. temperature	23
Figure 23.	Maximum transient duration vs. reset threshold overdrive	23
Figure 24.	AC testing input/output waveforms	25
Figure 25.	MR timing waveform	25
Figure 26.	STM1404 switchover diagram, condition A (V _{BAT} < V _{SW})	26
Figure 27.	STM1404 switchover diagram, condition B (V _{BAT} > V _{SW})	26
Figure 28.	Temperature hysteresis	30
Figure 29.	QFN16 – 16-lead, quad, flat package, no lead, 3x3mm body size, outline	31
Figure 30.	QFN16 – 16-lead, quad, flat package, no lead, 3x3mm, recommended footprint	32
Figure 31.	Topside marking information	34

Summary description

The STM1404 family of security supervisors are a low power family of intrusion (tamper) detection chips targeted at manufacturers of POS terminals and other systems, to enable them to meet **physical and/or environmental** intrusion monitoring requirements as mandated by various standards, such as Federal Information Processing Standards (FIPS) Pub 140 entitled “Security Requirements for Cryptographic Modules,” published by the National Institute of Standards and Technology, U.S. Department of Commerce), EMVCo, ISO, ZKA, and VISA PED.

STM1404 will target the highest security level 4 and include both physical and environmental (voltage and temperature) monitoring.

The STM1404 include Automatic Battery Switchover, $\overline{\text{RST}}$ Output (Open Drain), Manual (Push-button) Reset Input ($\overline{\text{MR}}$), Power-fail Comparator (PFI/ $\overline{\text{PFO}}$), Physical and/or Environmental Tamper Detect/Security Alarm, and Battery Low Voltage Detect features.

The STM1404A also offers a V_{REF} (1.237V) as an option on pin 9. On STM1404B/C this pin is V_{TPU} (internally switched V_{CC} or V_{BAT}).

V_{OUT} pin modes

The STM1404 is available in three versions, corresponding to three modes of the V_{OUT} pin (Supply Voltage Out), when the $\overline{\text{SAL}}$ (Security Alarm) is asserted (active-low) upon tamper detection:

STM1404A

V_{OUT} stays ON (at V_{CC} or V_{BAT}) when $\overline{\text{SAL}}$ is driven low (activated).

STM1404B

V_{OUT} is set to High-Z when $\overline{\text{SAL}}$ is driven low (activated).

STM1404C

V_{OUT} is driven to Ground when $\overline{\text{SAL}}$ is activated (may be used when V_{OUT} is connected directly to the V_{CC} pin of the external SRAM that holds the cryptographic codes).

All variants (see [Table 1: Device options](#)) are pin-compatible and available in a security-friendly, low profile, 16-pin QFN package.

Figure 1. Logic diagram

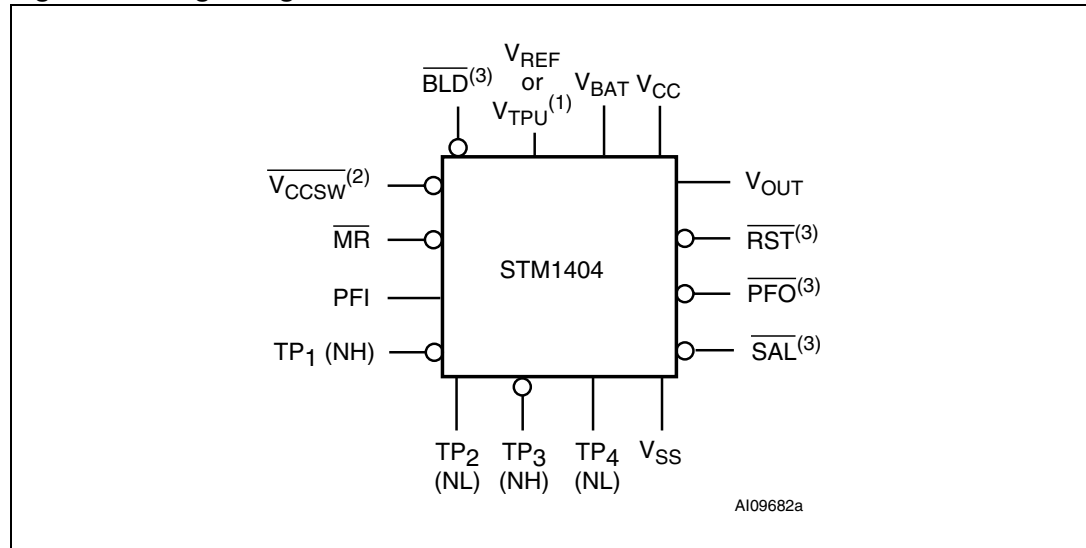

1. V_{REF} only for STM1404A; V_{TPU} for STM1404B/C.
2. Normal Mode: Low when V_{OUT} is internally switched to V_{CC} and High when V_{OUT} is internally switched to battery.
3. \overline{SAL} , \overline{RST} , \overline{PFO} , and \overline{BLD} are open drain.

Table 2. Signal names

$V_{CCSW}^{(1)}$	V_{CC} Switch output
MR	Manual (push-button) reset input
PFI	Power-fail input
TP ₁ - TP ₄	Independent physical tamper detect pins 1 through 4
V_{OUT}	Supply voltage output
$\overline{RST}^{(2)}$	Active-low reset output
$\overline{PFO}^{(2)}$	Power-fail output
$\overline{SAL}^{(2)}$	Security alarm output
$\overline{BLD}^{(2)}$	Battery low voltage detect
$V_{REF}^{(3)}$	1.237V Reference voltage
$V_{TPU}^{(3)}$	Tamper pull-up (V_{CC} or V_{BAT})
V_{BAT}	Back-up supply voltage
V_{CC}	Supply voltage
V_{SS}	Ground

1. Normal mode: low when V_{OUT} is internally switched to V_{CC} and high when V_{OUT} is internally switched to battery.
2. \overline{SAL} , \overline{RST} , \overline{PFO} , and \overline{BLD} are open drain.
3. V_{REF} only for STM1404A; V_{TPU} for STM1404B/C.

Note: See [Section : Pin descriptions on page 12](#) for details.

Figure 2. QFN16 connections

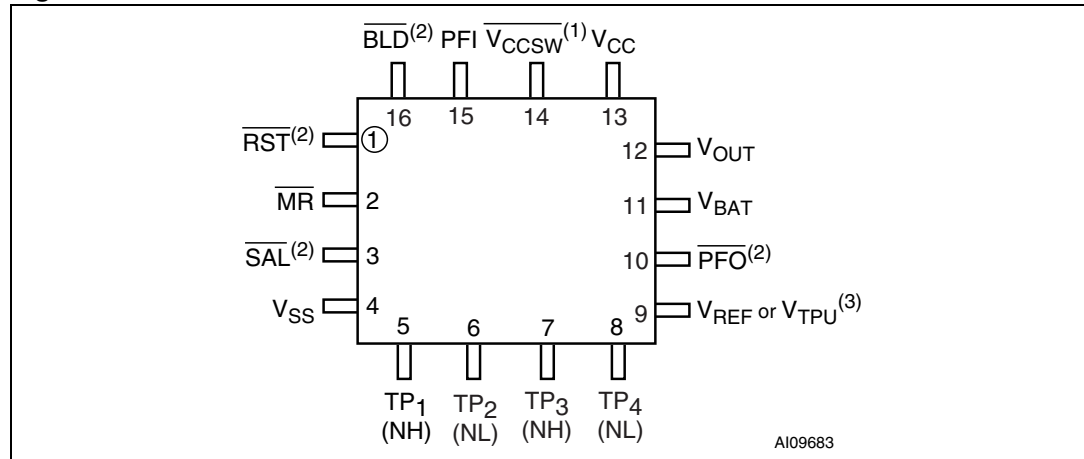

Note: See Section : Pin descriptions on page 12 for details.

1. Normal mode: low when V_{OUT} is internally switched to V_{CC} and high when V_{OUT} is internally switched to battery.
2. $\overline{\text{SAL}}$, $\overline{\text{RST}}$, $\overline{\text{PFO}}$, and $\overline{\text{BLD}}$ are open drain.
3. V_{REF} only for STM1404A; V_{TPU} for STM1404B/C.

Figure 3. Block diagram

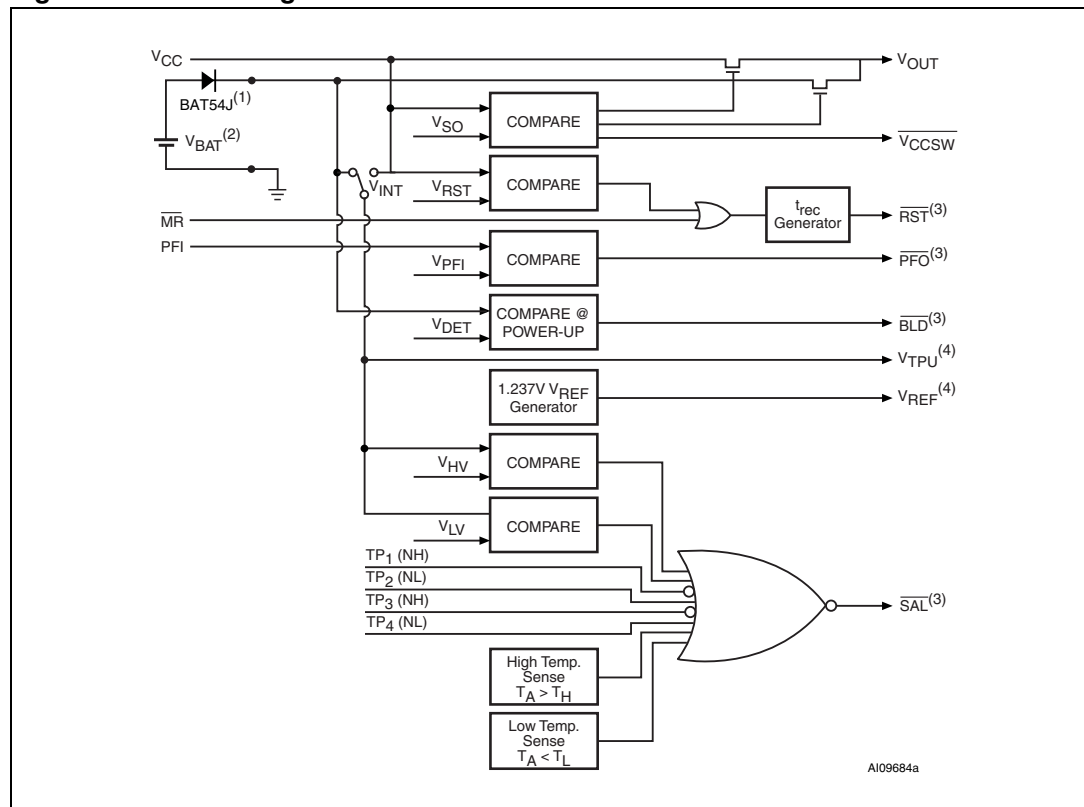

1. Required for battery-reverse charging protection.
2. User supplied.
3. Open drain.
4. V_{REF} only for STM1404A; V_{TPU} for STM1404B/C.

Figure 4. Hardware hookup

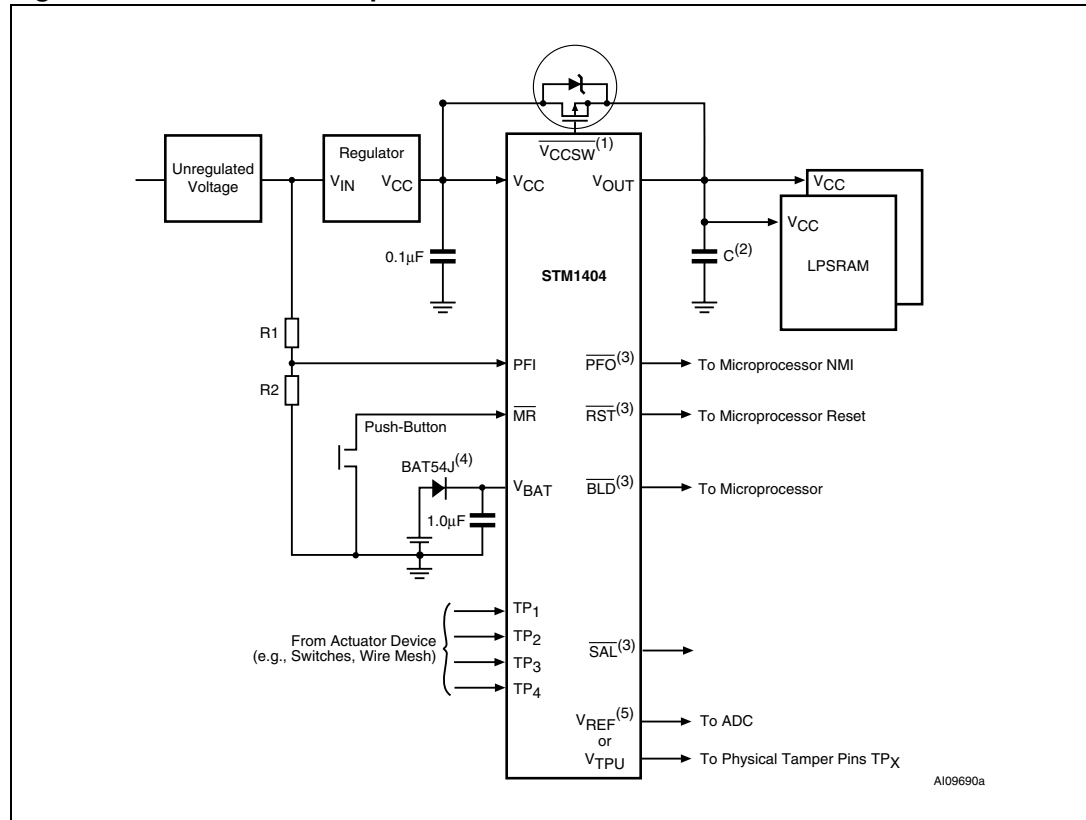

1. Normal mode: low when V_{OUT} is internally switched to V_{CC} and high when V_{OUT} is internally switched to battery.
2. Capacitor (C) is typically $\geq 10\mu\text{F}$.
3. Open drain
4. Diode is required for battery reverse charge protection.
5. V_{REF} only for STM1404A; V_{TPU} for STM1404B/C.

Figure 5. Tamper Pin (TP₁ or TP₃) Normally High (NH) external hookup (switch closed)

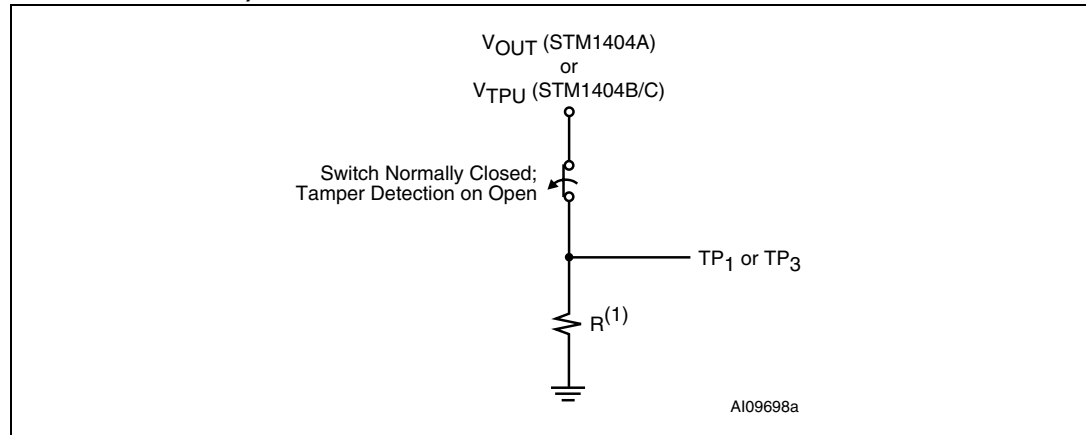

1. R typical is 10M Ω . Resistors must be protected against conductive materials.

Figure 6. Tamper Pin (TP₁ or TP₃) Normally High (NH) external hookup (switch open)

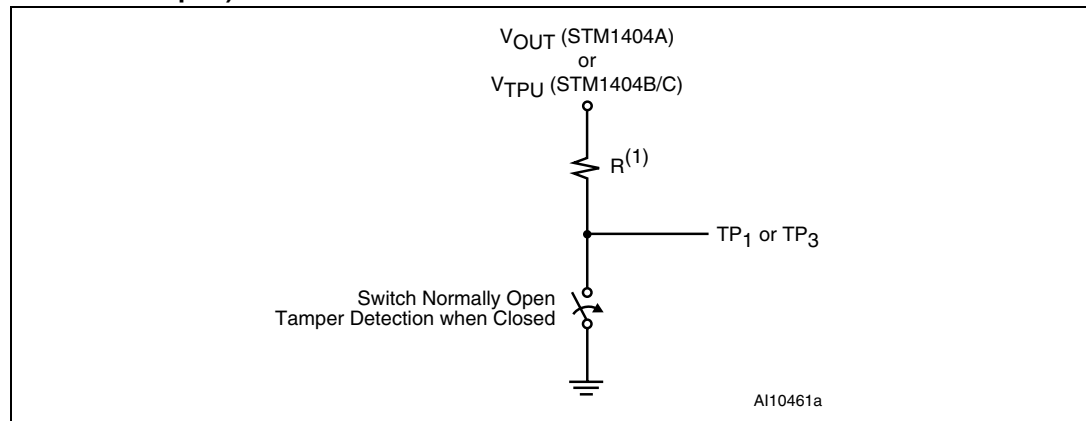

1. R typical is 10M Ω . Resistors must be protected against conductive materials.

Figure 7. Tamper Pin (TP₂ or TP₄) Normally Low (NL) external hookup (switch closed)

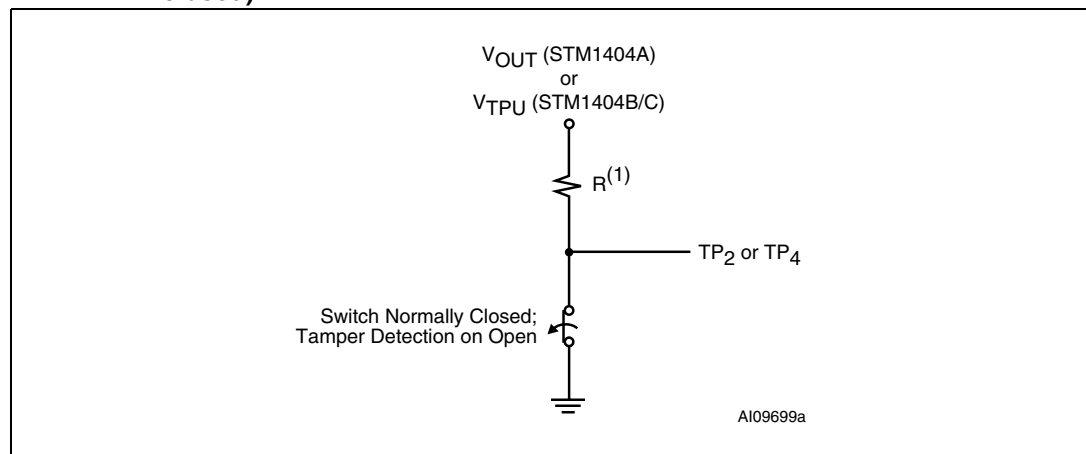

1. R typical is 10M Ω . Resistors must be protected against conductive materials.

Figure 8. Tamper Pin (TP₂ or TP₄) Normally Low (NL) external hookup (switch open)

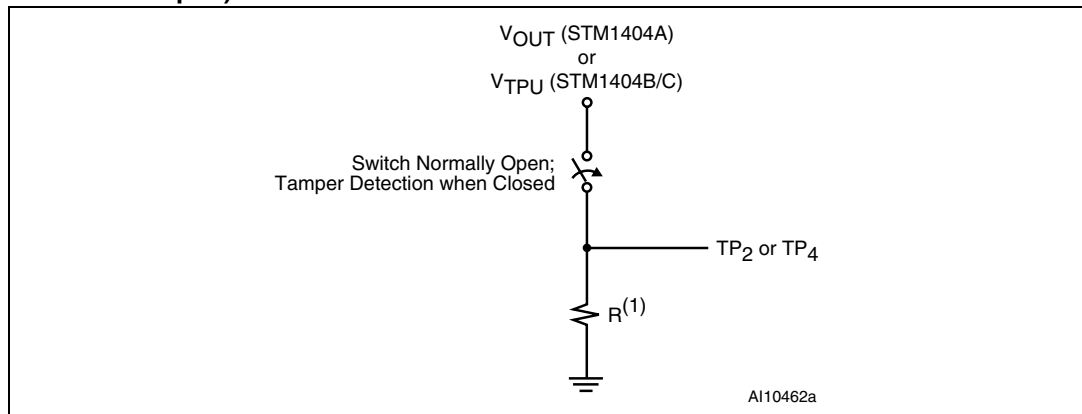

1. R typical is 10M Ω . Resistors must be protected against conductive materials.

Pin descriptions

See [Figure 1: Logic diagram](#) and [Table 2: Signal names](#) for a brief overview of the signals connected to this device.

$\overline{\text{SAL}}$, Security alarm output (open drain)

This signal can be generated when ANY of the following conditions occur:

- $V_{\text{INT}} > V_{\text{HV}}$, where V_{HV} = upper voltage trip limit (4.2V typ); and where $V_{\text{INT}} = V_{\text{CC}}$ or V_{BAT} ;
- $V_{\text{INT}} < V_{\text{LV}}$, where V_{LV} = lower voltage trip limit (2.0V typ); and where $V_{\text{INT}} = V_{\text{CC}}$ or V_{BAT} ; or
- When any of the physical tamper inputs, TP_1 to TP_4 , change from their normal states to the opposite (i.e., intrusion of a physical enclosure).
- $T_{\text{A}} > T_{\text{H}}$, where T_{H} is an upper temperature trip limit specified by the customer (+80°C, +85°C, and +95°C), factory-programmed (STM1404 only);
- $T_{\text{A}} < T_{\text{L}}$, where T_{L} is a lower temperature trip limit specified by the customer (−25°C or −35°C), factory-programmed (STM1404 only);

- Note:*
- 1 The default state of the $\overline{\text{SAL}}$ output during initial power-up is undetermined.
 - 2 The alarm function will operate either with V_{CC} on or when the part is internally switched from V_{CC} to V_{BAT} .

TP_1 , TP_3

Physical Tamper Detect Pin set normally to High (NH). They are connected externally through a closed switch or a high-impedance resistor to V_{OUT} (in the case of STM1404A) or V_{TPU} (in the case of STM1404B/C). A tamper condition will be detected when the input pin is pulled low (see [Figure 5](#) and [Figure 6 on page 10](#)). If not used, tie the pin to V_{OUT} (for STM1404A) or V_{TPU} (for STM1404B/C).

TP_2 , TP_4

Physical Tamper Detect Pin set normally to Low (NL). They are connected externally through a high-impedance resistor or a closed switch to V_{SS} . A tamper condition will be detected when the input pin is pulled high (see [Figure 7](#) and [Figure 8 on page 11](#)). If not used, tie the pin to V_{SS} .

$\overline{\text{Vccsw}}$, V_{CC} switch output

This output is low when V_{OUT} (see [Section : \$V_{\text{OUT}}\$ on page 14](#)) is internally switched to V_{CC} ; in this mode it may be used to turn on an external p-channel MOSFET switch which can source an external device directly from V_{CC} for currents greater than 80mA (bypassing the STM1404).

This pin goes high when V_{OUT} is internally switched to V_{BAT} and may be used as a “BATTERY ON” indicator.

If a Security Alarm ($\overline{\text{SAL}}$) is issued on Tamper, then the state of the $\overline{\text{Vccsw}}$ pin is as follows:

1. STM1404A (V_{OUT} remains ON when $\overline{\text{SAL}}$ is active-low): $\overline{\text{Vccsw}}$ pin will continue to operate in normal mode;
2. STM1404B (V_{OUT} is taken to High-Z when $\overline{\text{SAL}}$ is active-low): $\overline{\text{Vccsw}}$ pin will be set to High when this occurs; and
3. STM1404C (V_{OUT} is driven to Ground when $\overline{\text{SAL}}$ is active-low): $\overline{\text{Vccsw}}$ pin will be set to High when this occurs.

$\overline{\text{BLD}}$, V_{BAT} low voltage detect output (open drain)

This is an internally loaded test of the battery, activated only during a power-up sequence to insure that the battery is good either prior to or after encapsulation of the module. There are three customer options for V_{DET} :

- 2.3V (2.5V – external diode drop of about 0.2V) for a 3V lithium cell;
- 2.5V (2.7V – 0.2V) for a 3V lithium cell; or
- 3.2V (3.4V – 0.2V) for a 3.68V lithium “AA” battery.

This output pin will go active-low when it detects a voltage on the V_{BAT} pin below V_{DET} . $\overline{\text{BLD}}$ will be released when V_{CC} drops below V_{RST} .

Active-low $\overline{\text{RST}}$ output (open drain)

Goes low and stays low when V_{CC} drops below V_{RST} (Reset Threshold selected by the customer), or when $\overline{\text{MR}}$ is logic low. It remains low for t_{rec} (200ms, typical) AFTER V_{CC} rises above V_{RST} and $\overline{\text{MR}}$ goes from low to high.

$\overline{\text{MR}}$, Manual reset input

A logic low on $\overline{\text{MR}}$ asserts the $\overline{\text{RST}}$ output. The $\overline{\text{RST}}$ output remains asserted as long as $\overline{\text{MR}}$ is low and for t_{rec} after $\overline{\text{MR}}$ returns to high. This active low input has an internal 40k Ω (typical) pull-up resistor. It can be driven from a TTL or CMOS Logic line or shorted to Ground with a switch. Leave it open if unused.

$\overline{\text{PFO}}$, Power-fail output (open drain)

When PFI is less than V_{PFI} (Power-fail Input Threshold Voltage) or V_{CC} falls below V_{SW} (battery switchover threshold ~ 2.4V), $\overline{\text{PFO}}$ goes low, otherwise, $\overline{\text{PFO}}$ remains high. Leave this pin open if unused.

PFI, Power-fail input

When PFI is less than V_{PFI} , or when V_{CC} falls below V_{SW} (see $\overline{\text{PFO}}$, above), $\overline{\text{PFO}}$ goes active-low. If this function is unused, connect this pin to V_{SS} .

V_{REF} Reference voltage output (1.237, typ)

This is valid only when V_{CC} is between 2.4V and 3.6V. When V_{CC} falls below 2.4V (V_{SW}), V_{REF} is pulled to Ground with an internal 100k Ω resistor. This is an optional feature available on the STM1404A. On the STM1404B/C, this pin is V_{TPU} (internally switched V_{CC} or V_{BAT}). If unused, this pin should float.

V_{OUT}

This is the Supply Voltage Output. When V_{CC} rises above V_{SO} (Battery Backup Switchover Voltage), V_{OUT} is supplied from V_{CC} . In this condition, V_{OUT} may be connected externally to V_{CC} through a p-channel MOSFET switch. When V_{CC} falls below the lower value of V_{SW} (~2.4V), or V_{BAT} , V_{OUT} is supplied from V_{BAT} . It is recommended that the V_{OUT} pin be connected externally to a capacitor that will retain a charge for a period of time, in case an intruder forces V_{CC} or V_{BAT} to Ground. The rectifying diode connected from the positive terminal of the battery to the V_{BAT} pin of the STM1404 will prevent discharge of the capacitor.

Three variations of parts will be offered with the following options:

1. STM1404A: V_{OUT} remains ON when \overline{SAL} is active-low; $\overline{V_{CCSW}}$ pin will continue to operate in normal mode (see [Section : Vccsw, V_{CC} switch output on page 12](#));
2. STM1404B: V_{OUT} is taken to High-Z when \overline{SAL} is active-low; $\overline{V_{CCSW}}$ pin will be set to High when this occurs; and
3. STM1404C: V_{OUT} is driven to Ground when \overline{SAL} is active-low; $\overline{V_{CCSW}}$ pin will be set to High when this occurs.

V_{TPU}

For STM1404B and STM1404C, this pin provides pull-up voltage for the physical tamper pins (TP1-4). This pin is not to be used as voltage supply source for any other purpose.

Note: V_{TPU} is the internally switched supply voltage from either the V_{CC} pin or the V_{BAT} pin.

V_{CC}

This is the Supply voltage (2.2V to 3.6V).

V_{BAT}

This is the secondary (backup battery) supply voltage. The pin is connected to the positive terminal of the battery with a rectifying diode like the BAT54J from STMicroelectronics for reverse charge protection. Voltage at this pin, after diode rectification, will be approximately 0.2V less than the battery voltage, and will depend on the type of battery used as well as the I_{BAT} being drawn. (A capacitor of at least 1.0 μ F connected between the V_{BAT} pin and V_{SS} is required.) If no battery is used, connect the V_{BAT} pin to the V_{CC} pin.

V_{SS}

Ground, V_{SS} , is the reference for the power supply. It must be connected to system ground.

Operation

Reset input

The STM1404 Security Supervisor asserts a reset signal to the MCU whenever V_{CC} goes below the reset threshold (V_{RST}), or when the Push-button Reset Input (\overline{MR}) is taken low. \overline{RST} is guaranteed to be a logic low for $0V < V_{CC} < V_{RST}$ if V_{BAT} is greater than 1V. Without a back-up battery, \overline{RST} is guaranteed valid down to $V_{CC} = 1V$.

During power-up, once V_{CC} exceeds the reset threshold an internal timer keeps \overline{RST} low for the reset time-out period, t_{rec} . After this interval \overline{RST} returns high.

If V_{CC} drops below the reset threshold, \overline{RST} goes low. Each time \overline{RST} is asserted, it stays low for at least the reset time-out period (t_{rec}). Any time V_{CC} goes below the reset threshold the internal timer clears. The reset timer starts when V_{CC} returns above the reset threshold.

Push-button reset input

A logic low on \overline{MR} asserts reset. Reset remains asserted while \overline{MR} is low, and for t_{rec} (see [Figure 25 on page 25](#)) after it returns high. The \overline{MR} input has an internal 40k Ω pull-up resistor, allowing it to be left open if not used. This input can be driven with TTL/CMOS-logic levels or with open-drain/collector outputs. Connect a normally open momentary switch from \overline{MR} to Ground to create a manual reset function; external debounce circuitry is not required. If \overline{MR} is driven from long cables or the device is used in a noisy environment, connect a 0.1 μF capacitor from \overline{MR} to V_{SS} to provide additional noise immunity. \overline{MR} may float, or be tied to V_{CC} when not used.

Back-up battery switchover

In the event of a power failure, it may be necessary to preserve the contents of external SRAM through V_{OUT} . With a backup battery installed with voltage V_{BAT} , the devices automatically switch the SRAM to the back-up supply when V_{CC} falls.

Note: If back-up battery is not used, connect both V_{BAT} and V_{OUT} to V_{CC} .

This family of Security Supervisors does not always connect V_{BAT} to V_{OUT} when V_{BAT} is greater than V_{CC} . V_{BAT} connects to V_{OUT} (through a 100 Ω switch) when V_{CC} is below V_{SW} (~2.4V) or V_{BAT} (whichever is lower). This is done to allow the back-up battery (e.g., a 3.6V battery) to have a higher voltage than V_{CC} .

Assuming that $V_{BAT} > 2.0V$, switchover at V_{SO} ensures that battery back-up mode is entered before V_{OUT} gets too close to the 2.0V minimum required to reliably retain data in most external SRAMs. When V_{CC} recovers, hysteresis is used to avoid oscillation around the V_{SO} point. V_{OUT} is connected to V_{CC} through a 3 Ω PMOS power switch.

Note: The back-up battery may be removed while V_{CC} is valid, assuming V_{BAT} is adequately decoupled (0.1 μF typ), without danger of triggering a reset.

Table 3. I/O status in battery back-up

Pin	Status
V _{OUT}	Connected to V _{BAT} through internal switch
V _{CC}	Disconnected from V _{OUT}
PFI	Disabled
PFO	Logic low
MR	Disabled
RST	Logic low
V _{BAT}	Connected to V _{OUT}
V _{CCSW}	Logic high
V _{REF}	Pulled to V _{SS} below 2.4V (V _{SW})
BLD	Logic high
V _{TPU}	Connected to V _{BAT} through an internal switch

The Power-fail Input (PFI) is compared to an internal reference voltage (independent from the V_{RST} comparator). If PFI is less than the power-fail threshold (V_{PFI}), the Power-Fail Output (PFO) will go low. This function is intended for use as an undervoltage detector to signal a failing power supply. Typically PFI is connected through an external voltage divider (see [Figure 4 on page 9](#)) to either the unregulated DC input (if it is available) or the regulated output of the V_{CC} regulator. The voltage divider can be set up such that the voltage at PFI falls below V_{PFI} several milliseconds before the regulated V_{CC} input to the STM1404 or the microprocessor drops below the minimum operating voltage.

During battery back-up, the power-fail comparator is turned off and PFO goes (or remains) low (see [Figure 9 on page 17](#)). This occurs after V_{CC} drops below V_{SW} (~2.4V). When power returns, the power-fail comparator is enabled and PFO follows PFI. If the comparator is unused, PFI should be connected to V_{SS} and PFO left unconnected. PFO may be connected to MR so that a low voltage on PFI will generate a reset output.

Applications information

These Supervisor circuits are not short-circuit protected. Shorting V_{OUT} to ground - excluding power-up transients such as charging a decoupling capacitor - destroys the device. Decouple both V_{CC} and V_{BAT} pins to ground by placing 0.1µF capacitors as close to the device as possible.

Figure 9. Power-fail comparator waveform

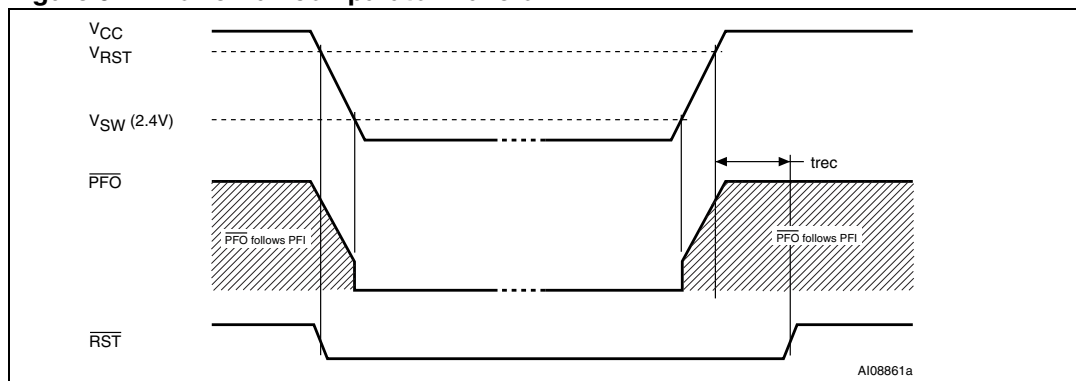

Negative-going V_{CC} transients and undershoot

The STM1404 devices are relatively immune to negative-going V_{CC} transients (glitches). [Figure 23 on page 23](#) was generated using a negative pulse applied to V_{CC} , starting at $V_{RST} + 0.3V$ and ending below the reset threshold by the magnitude indicated (comparator overdrive). The graph indicates the maximum pulse width a negative V_{CC} transient can have without causing a reset pulse. As the magnitude of the transient increases (further below the threshold), the maximum allowable pulse width decreases. Any combination of duration and overdrive which lies under the curve will NOT generate a reset signal. Typically, a V_{CC} transient that goes 100mV below the reset threshold and lasts 40 μ s or less will not cause a reset pulse. A 0.1 μ F bypass capacitor mounted as close as possible to the V_{CC} pin provides additional transient immunity (see [Figure 10](#)).

In addition to transients that are caused by normal SRAM operation, power cycling can generate negative voltage spikes on V_{CC} that drive it to values below V_{SS} by as much as one volt. These negative spikes can cause data corruption in the SRAM while in battery backup mode. To protect from these voltage spikes, STMicroelectronics recommends connecting a schottky diode from V_{CC} to V_{SS} (cathode connected to V_{CC} , anode to V_{SS}). Schottky diode 1N5817 is recommended for through hole and MBRS120T3 is recommended for surface mount.

Figure 10. Supply voltage protection

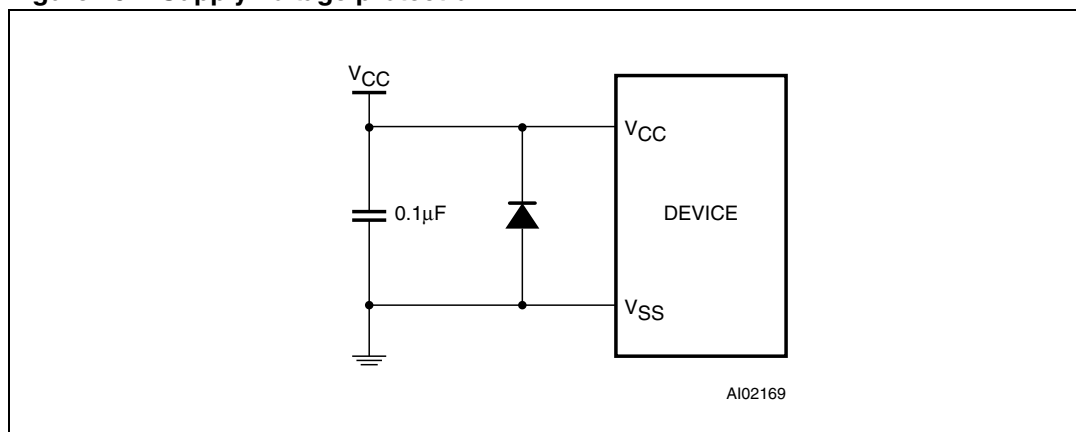

Tamper detection

Physical

There are four (4) high-impedance physical tamper detect input pins, 2 normally set to High (NH) and 2 normally set to Low (NL). Each input is designed with a glitch immunity (see [Table 7 on page 30](#)). These inputs can be connected externally to several types of actuator devices (e.g., switches, wire mesh). A tamper on any one of the four inputs that causes its state to change will trigger the security alarm ($\overline{\text{SAL}}$) and drive it to active-low. Once the tamper condition no longer exists, the $\overline{\text{SAL}}$ will return to its normal High state.

TP₁ and TP₃ are set Normally to High (NH). They are connected externally through a closed switch or a high-impedance resistor to V_{OUT} (in the case of STM1404A or STM1404A) or V_{TPU} (in the case of STM1404B/C). A tamper condition will be detected when the input pin is pulled low (see [Figure 5](#) and [Figure 6 on page 10](#)). If not used, tie the pin to V_{OUT} or V_{TPU}.

TP₂ and TP₄ are set Normally to Low (NL). They are connected externally through a high-impedance resistor or a closed switch to V_{SS}. A tamper condition will be detected when the input pin is pulled high (see [Figure 7](#) and [Figure 8 on page 11](#)). If not used, tie the pin to V_{SS}.

Supply voltage

The internally switched supply voltage, V_{INT} (either V_{CC} input or V_{BAT} input) is continuously monitored. If V_{INT} should exceed the over voltage trip point, V_{HV} (set at 4.2V, typical), or should go below the under voltage trip point, V_{LV} (set at 2.0V, typical). $\overline{\text{SAL}}$ will be driven active-low. Once the tamper condition no longer exists, the $\overline{\text{SAL}}$ pin will return to its normal High state.

Temperature

The STM1404 has a built-in, bandgap-based sensor to monitor the temperature. If a preset (customer-selectable, factory-programmed) over-temperature trip point (T_H) or under-temperature trip point (T_L) is exceeded, the $\overline{\text{SAL}}$ is asserted low.

When no tamper condition exists, $\overline{\text{SAL}}$ is normally High (see [Section : Pin descriptions on page 12](#)).

When a tamper is detected, the $\overline{\text{SAL}}$ is activated (driven low), independent of the part type. V_{OUT} can be driven to one of three states, depending on which variant of STM1404 is being used (see [Table 1 on page 1](#)):

- ON;
- High-Z; or
- Ground (V_{SS}).

Note: The STM1404 must be initially powered above V_{RST} to enable the tamper detection alarms. For example, if the battery is on while V_{CC} = 0V, no alarm condition can be detected until V_{CC} rises above V_{RST} (and t_{rec} expires). From this point on, alarms can be detected either on battery or V_{CC}. This is done to avoid false alarms when the device goes from no power to its operational state.

Typical operating characteristics

Note: Typical values are at $T_A = 25^\circ\text{C}$.

Figure 11. V_{BAT} -to- V_{OUT} on-resistance vs. temperature

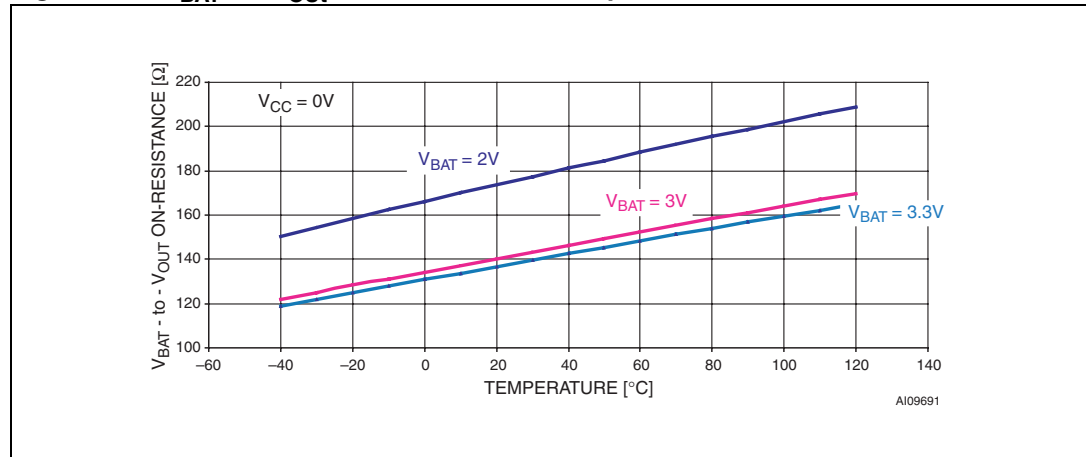

Figure 12. Supply current vs. temperature (no load)

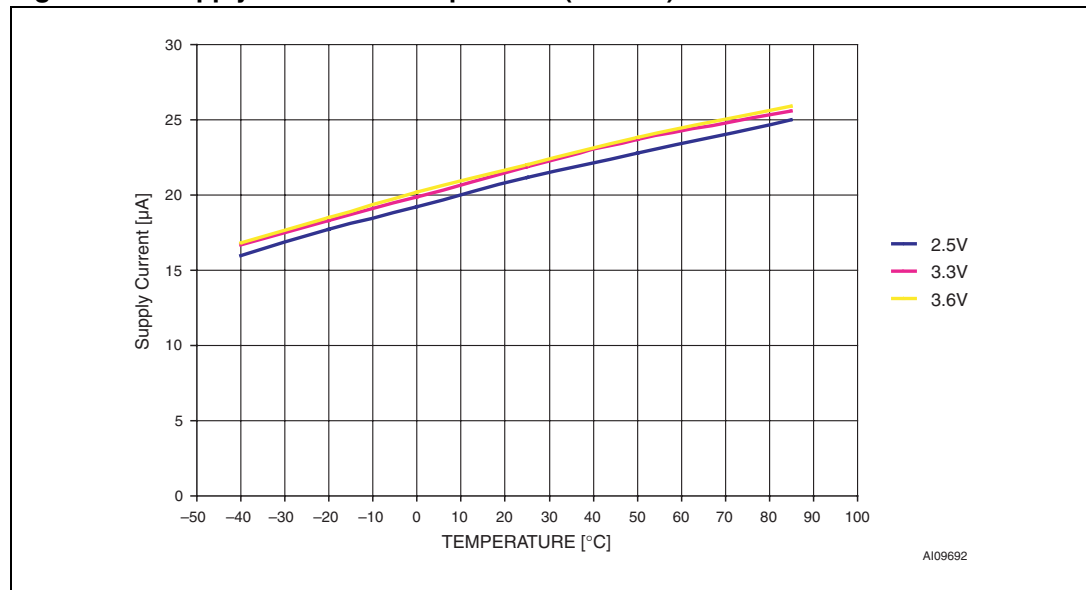

Figure 13. V_{PFI} threshold vs. temperature

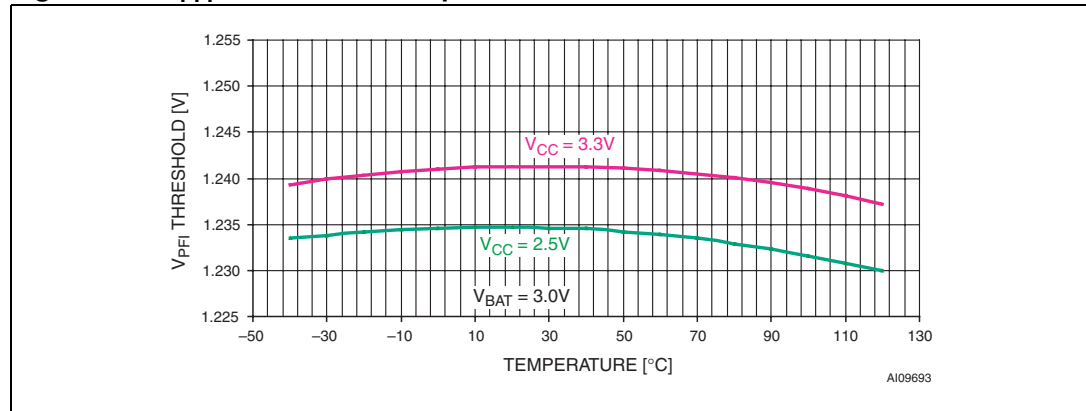

Figure 14. Reset comparator propagation delay vs. temperature

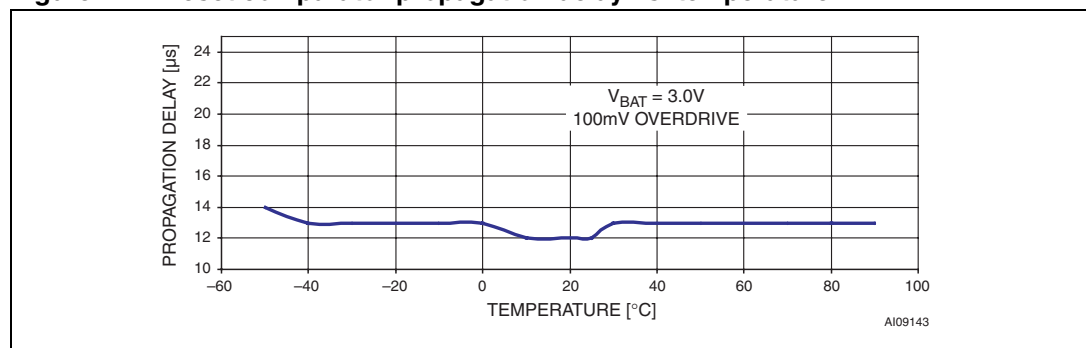

Figure 15. Power-up t_{rec} vs. temperature

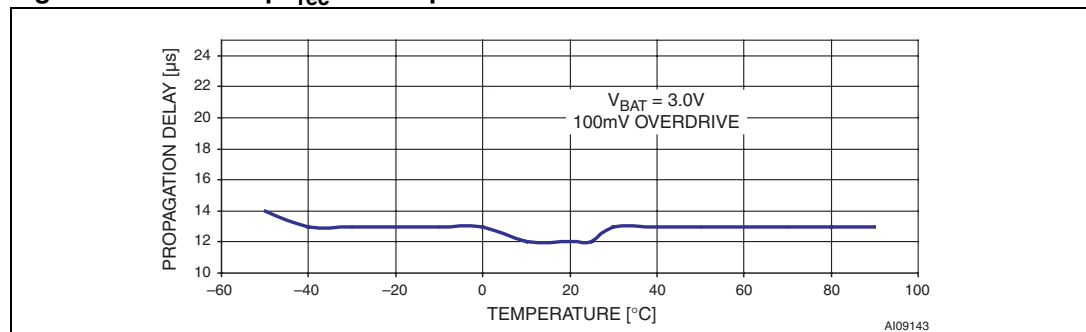

Figure 16. Normalized reset threshold vs. temperature

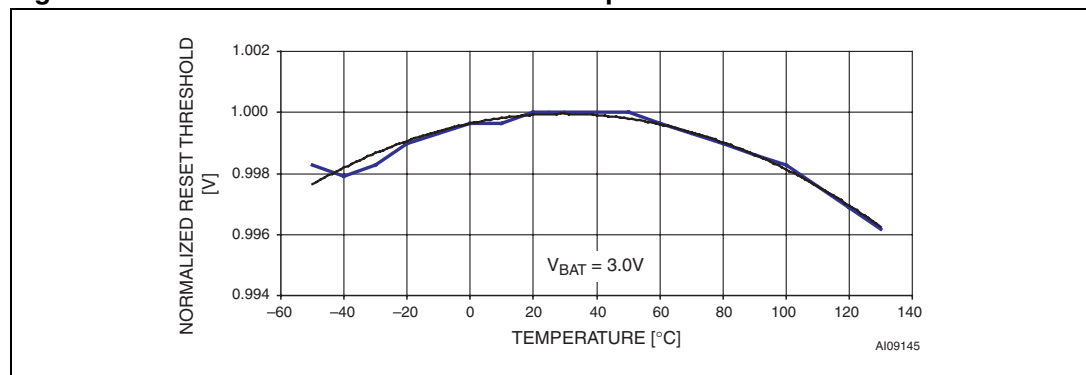

Figure 17. PFI to PFO propagation delay vs. temperature

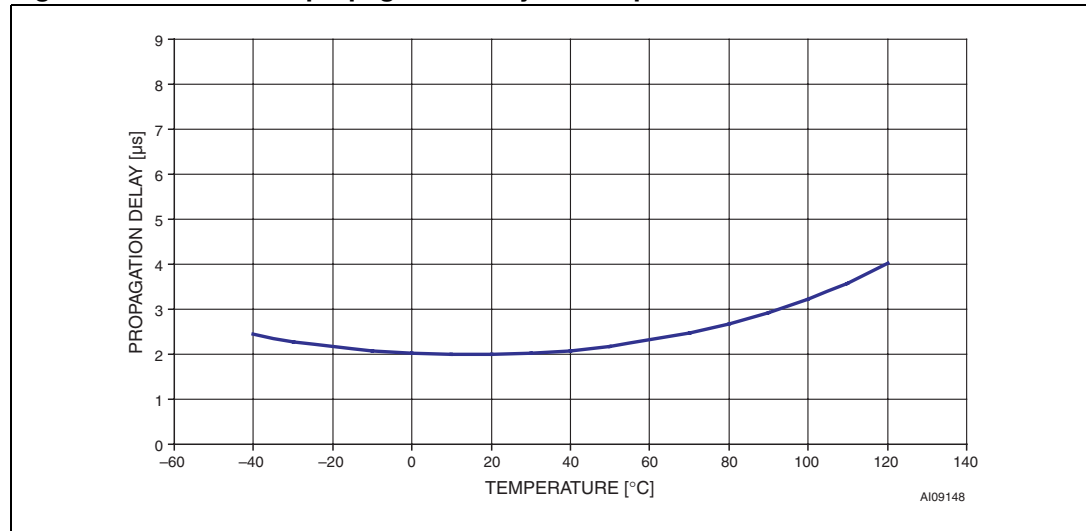

Figure 18. RST output voltage vs. supply voltage

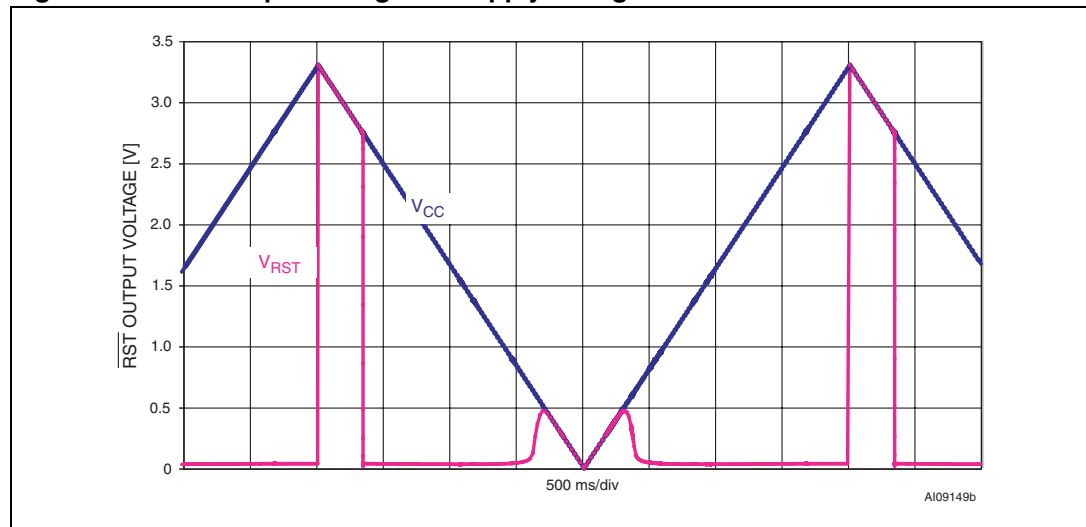

Figure 19. RST response time (assertion)

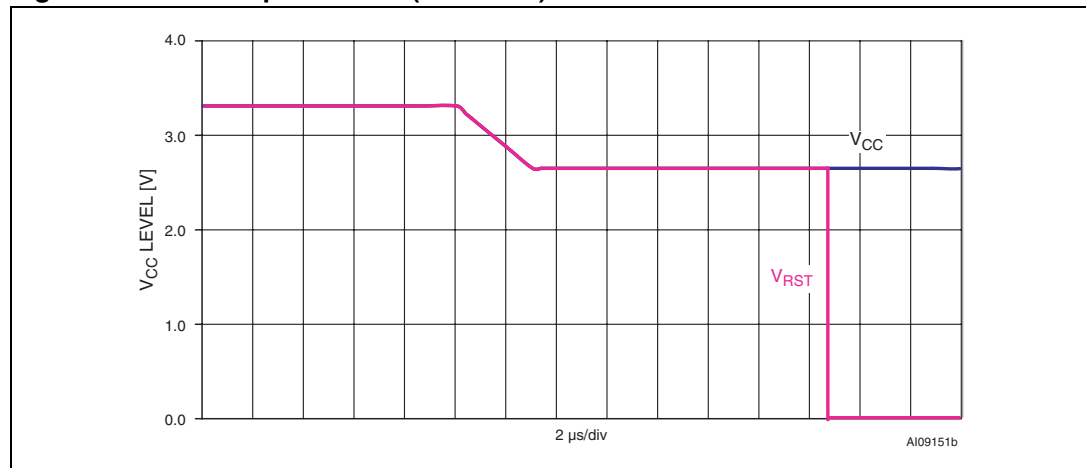

Figure 20. Power-fail comparator response time (assertion)

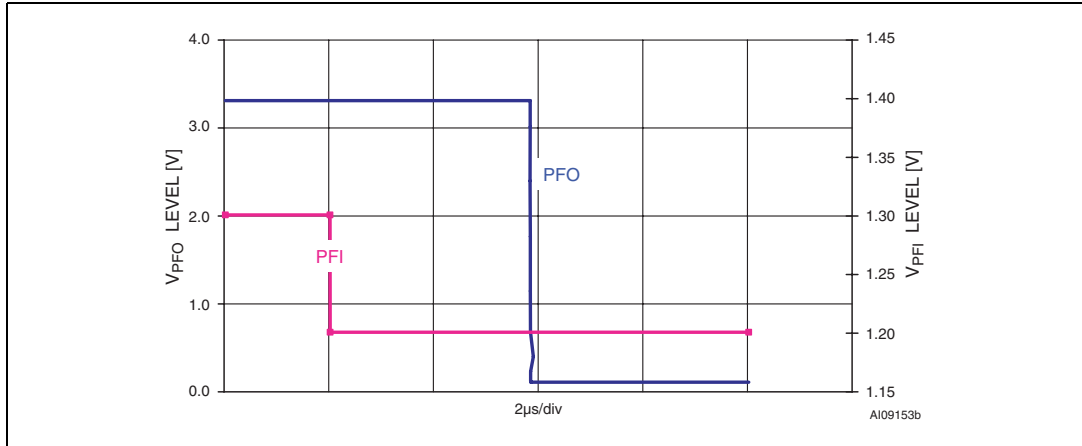

Figure 21. Power-fail comparator response time (de-assertion)

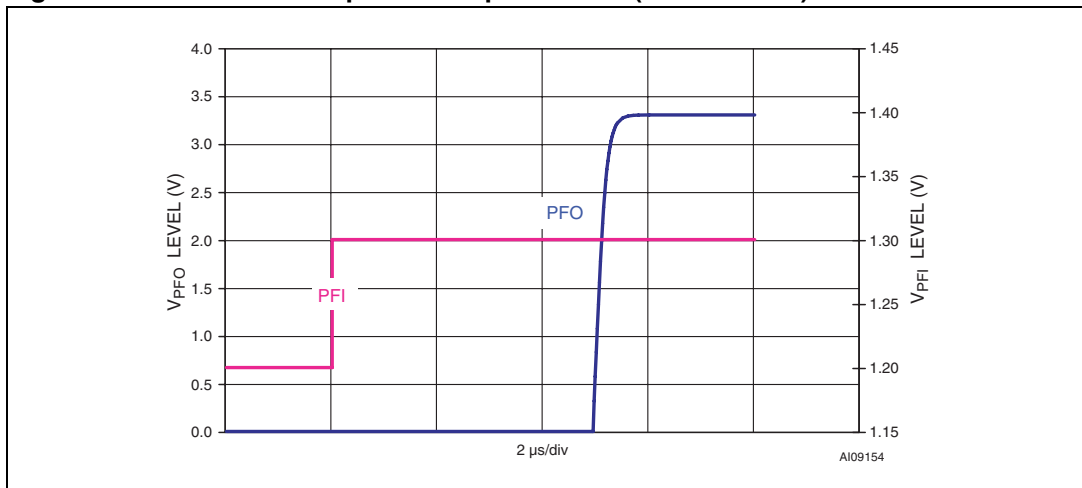

Figure 22. V_{CC} to reset propagation delay vs. temperature

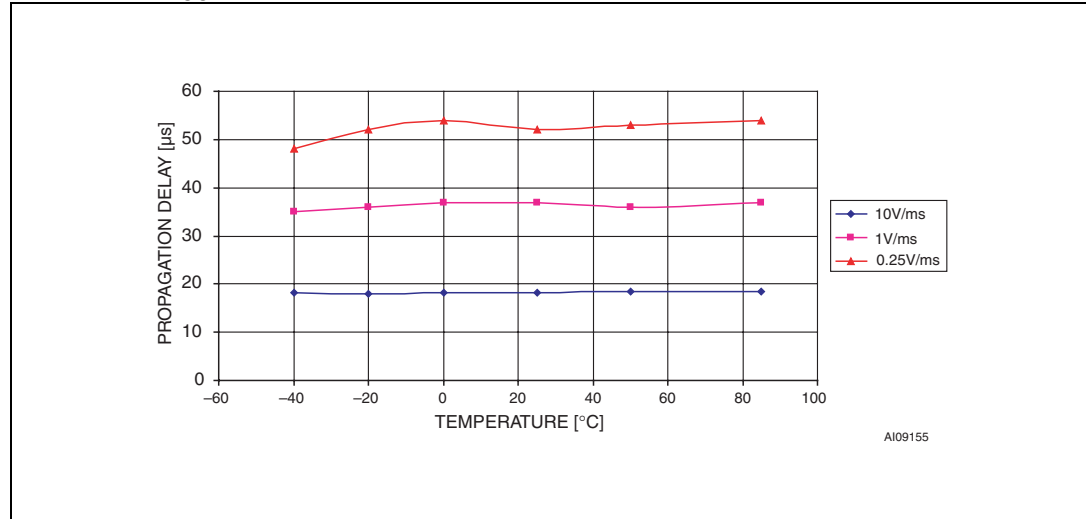
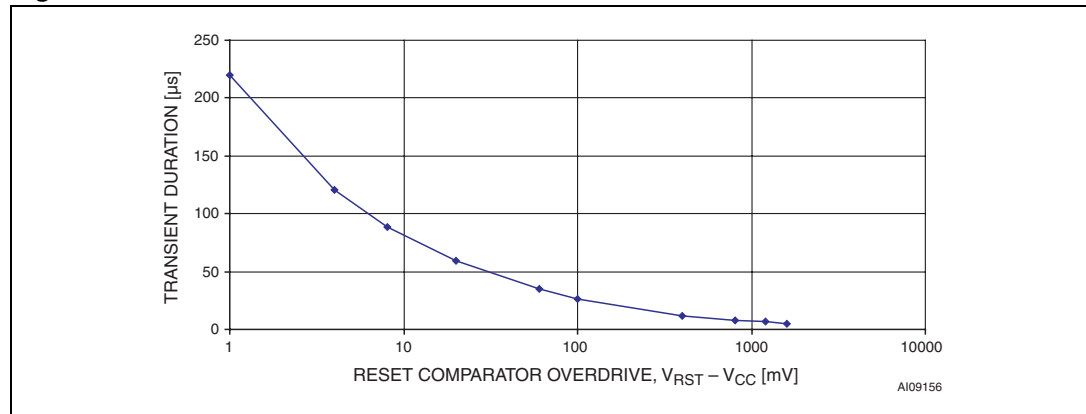

Figure 23. Maximum transient duration vs. reset threshold overdrive



Maximum rating

Stressing the device above the rating listed in the Absolute Maximum Ratings table may cause permanent damage to the device. These are stress ratings only and operation of the device at these or any other conditions above those indicated in the Operating sections of this specification is not implied. Exposure to Absolute Maximum Rating conditions for extended periods may affect device reliability. Refer also to the STMicroelectronics SURE Program and other relevant quality documents.

Table 4. Absolute maximum ratings

Symbol	Parameter	Value	Unit
T_{STG}	Storage temperature (V_{CC} Off, V_{BAT} Off)	-55 to 150	°C
$T_{SLD}^{(1)}$	Lead solder temperature for 10 seconds	260	°C
V_{IO}	Input or output voltage	-0.3 to $V_{CC} + 0.3$	V
V_{CC}/V_{BAT}	Supply voltage	-0.3 to 4.5	V
I_O	Output current	20	mA
P_D	Power dissipation	320	mW

1. Reflow at peak temperature of 255°C to 260°C for < 30 seconds (total thermal budget not to exceed 180°C for between 90 to 150 seconds).

DC and AC parameters

This section summarizes the operating measurement conditions, and the DC and AC characteristics of the device. The parameters in the DC and AC characteristics Tables that follow, are derived from tests performed under the Measurement Conditions summarized in [Table 5: Operating and AC measurement conditions](#). Designers should check that the operating conditions in their circuit match the operating conditions when relying on the quoted parameters.

Table 5. Operating and AC measurement conditions

Parameter	STM1404	Unit
V_{CC}/V_{BAT} supply voltage	2.2 to 3.6	V
Ambient operating temperature (T_A)	-40 to 85	°C
Input rise and fall times	≤ 5	ns
Input pulse voltages	0.2 to $0.8V_{CC}$	V
Input and output timing ref. voltages	0.3 to $0.7V_{CC}$	V

Figure 24. AC testing input/output waveforms

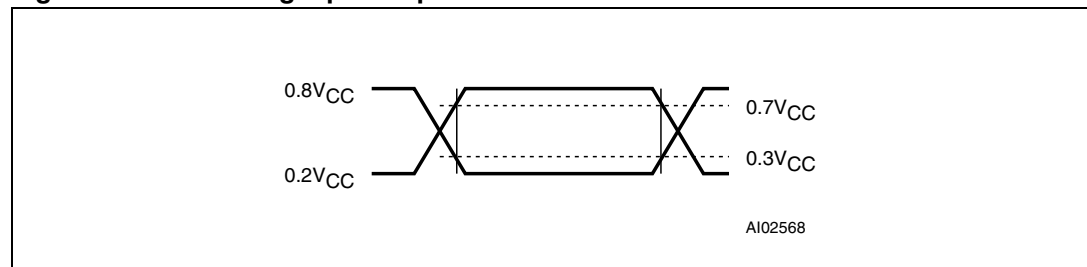

Figure 25. \overline{MR} timing waveform

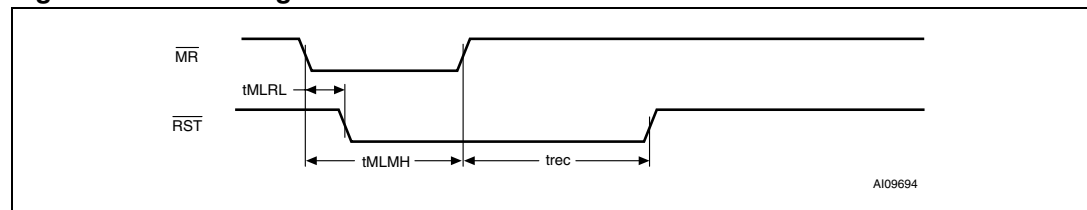

Figure 26. STM1404 switchover diagram, condition A ($V_{BAT} < V_{SW}$)

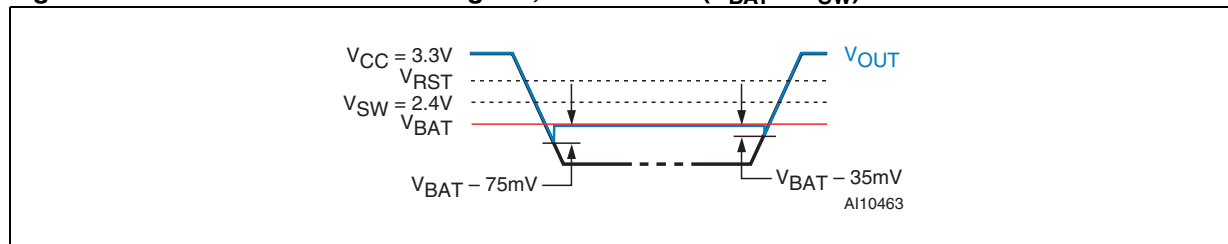

Figure 27. STM1404 switchover diagram, condition B ($V_{BAT} > V_{SW}$)

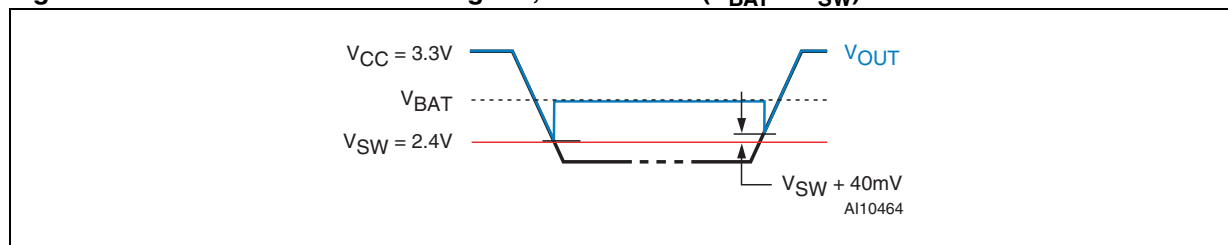

Table 6. DC and AC characteristics

Sym	Alternative	Description	Test condition ⁽¹⁾	Min	Typ	Max	Unit
$V_{CC}, V_{BAT}^{(2)}$		Operating voltage	$T_A = -40$ to $+85^\circ\text{C}$	2.2		3.6	V
I_{CC}		V_{CC} supply current (STM1404A)	Typ @ 3.3V, 25°C		50	65	μA
		V_{CC} supply current (STM1404B,C)			35	50	μA
		V_{CC} supply current in battery back-up mode	Excluding I_{OUT} ($V_{BAT} = 2.3\text{V}, V_{CC} = 2.0\text{V}, MR = V_{CC}$)		25	35	μA
$I_{BAT}^{(3)}$		V_{BAT} supply current in battery back-up mode	Excluding I_{OUT} ($V_{BAT} = 3.6\text{V}$)		5.3	8.0	μA
V_{OUT1}		V_{OUT} voltage (active)	$I_{OUT1} = 5\text{mA}^{(4)}$ ($V_{CC} > V_{SW}$)	$V_{CC} - 0.03$	$V_{CC} - 0.015$		V
			$I_{OUT1} = 80\text{mA}$ ($V_{CC} > V_{SW}$)	$V_{CC} - 0.3$	$V_{CC} - 0.15$		V
			$I_{OUT1} = 250\mu\text{A}, V_{CC} > V_{SW}^{(4)}$	$V_{CC} - 0.0015$	$V_{CC} - 0.0006$		V
V_{OUT2}		V_{OUT} voltage (battery back-up)	$I_{OUT2} = 250\mu\text{A}, V_{BAT} = 2.2\text{V}$	$V_{BAT} - 0.1$	$V_{BAT} - 0.04$		V
			$I_{OUT2} = 1\text{mA}, V_{BAT} = 2.2\text{V}$		$V_{BAT} - 0.16$		V
V_{TPU1}		Internal switched supply voltage (active)	$I_{SOURCE} = 5\text{mA}$ ($V_{CC} > V_{SW}$)	$V_{CC} - 0.3$			V

Table 6. DC and AC characteristics (continued)

Sym	Alternative	Description	Test condition ⁽¹⁾	Min	Typ	Max	Unit
V _{TPU2}		Internal switched supply voltage (battery back-up)	I _{SOURCE} = 1mA (V _{BAT} = 2.2V)		V _{BAT} - 0.10		V
I _{LI}		Input leakage current (\overline{MR})	$\overline{MR} = 0V$; V _{CC} = 3V	20	75	350	μA
		Input leakage current (PFI)	0V = V _{IN} = V _{CC}	-25	2	+25	nA
		Input leakage current (TP1-TP4)	0V = V _{IN} = V _{CC}	-1		+1	μA
I _{LO}		Output leakage current	0V = V _{IN} = V _{CC} ⁽⁵⁾	-1		+1	μA
V _{IH}		Input high voltage (\overline{MR})	V _{RST} (max) < V _{CC} < 3.6V	0.7V _{CC}			V
V _{IL}		Input low voltage (\overline{MR})					0.3V _{CC}
V _{OL}		Output low voltage (\overline{PFO} , \overline{RST} , \overline{Vccsw} , \overline{SAL} , \overline{BLD})	V _{CC} = V _{RST} (max), I _{SINK} = 3.2mA			0.3	V
V _{OL}		Output low voltage (\overline{RST})	I _{OL} = 40μA; V _{CC} = 1.0V; V _{BAT} = V _{CC} ; T _A = 0°C to 85°C			0.3	V
			I _{OL} = 200μA; V _{CC} = 1.2V; V _{BAT} = V _{CC}			0.3	V

Table 6. DC and AC characteristics (continued)

Sym	Alternative	Description	Test condition ⁽¹⁾	Min	Typ	Max	Unit	
V _{OH}		V _{OH} battery back-up (V _{CCSW})	I _{SOURCE} = 100μA,	0.8V _{BAT}			V	
		Pull-up supply voltage (open drain)	\overline{RST} , \overline{SAL} , \overline{BLD} , \overline{PFO}			3.6	V	
Power-fail comparator								
V _{PFI}		PFI input threshold	PFI falling (V _{CC} < 3.6V)	1.212	1.237	1.262	V	
		PFI hysteresis	PFI rising (V _{CC} < 3.6V)		10	20	mV	
t _{PF}		PFI to \overline{PFO} propagation delay			2		μs	
Battery switchover								
V _{SO}		Battery back-up switchover voltage ⁽⁶⁾⁽⁷⁾	Power-down	V _{BAT} > V _{SW}		V _{SW}	V	
				V _{BAT} < V _{SW}		V _{BAT}	V	
			Power-up	V _{BAT} > V _{SW}		V _{SW}	V	
				V _{BAT} < V _{SW}		V _{BAT}	V	
		V _{SW}				2.4		V
		Hysteresis				40		mV
Battery low voltage detect								
V _{DET}		Battery detect threshold	On power-up only	M	2.25	2.30	2.34	V
				N	2.45	2.50	2.55	V
				O	3.14	3.20	3.26	V
Voltage reference (option for STM1404A)⁽⁸⁾								
V _{REF}		Voltage reference (see Section : V_{REF} Reference voltage output (1.237, typ) on page 13)	0°C to 85°C	1.212	1.237	1.262	V	
			-40° to 0°C	1.200	1.237	1.274	V	
I _{REF+}		Source current	0°C to 85°C	15	25		μA	
			-40° to 0°C	10	15		μA	
I _{REF-}		Sink current		10	13		μA	
V _n		Output voltage noise	f = 100Hz to 100kHz		10-100		μV _{rms}	

Table 6. DC and AC characteristics (continued)

Sym	Alternative	Description	Test condition ⁽¹⁾	Min	Typ	Max	Unit	
Reset thresholds								
$V_{RST}^{(9)}$		Reset threshold	T	V_{CC} falling	3.00	3.075	3.15	V
				V_{CC} rising	3.00	3.085	3.17	V
			S	V_{CC} falling	2.85	2.925	3.00	V
				V_{CC} rising	2.85	2.935	3.02	V
			R	V_{CC} falling	2.55	2.625	2.70	V
				V_{CC} rising	2.55	2.635	2.72	V
t_{rec}		\overline{RST} pulse width		140	200	280	ms	
Push-button reset input								
t_{MLMH}	t_{MR}	\overline{MR} pulse width		100			ns	
t_{MLRL}	t_{MRD}	\overline{MR} to \overline{RST} output delay			60	500	ns	

- Valid for ambient operating temperature: $T_A = -40$ to 85°C ; $V_{CC} = V_{RST}$ (max) to 3.6V; and $V_{BAT} = 2.8\text{V}$ (except where noted); typical values are for 3.3V and 25°C .
- V_{CC} supply current, logic input leakage, push-button reset functionality, PFI functionality, state of \overline{RST} tested at $V_{BAT} = 3.6\text{V}$, and $V_{CC} = 3.6\text{V}$. The state of \overline{RST} and \overline{PFO} is tested at $V_{CC} = V_{CC}$ (min). V_{BAT} is voltage measured at the pin.
- Tested at $V_{BAT} = 3.6\text{V}$, and $V_{CC} = 0\text{V}$.
- Guaranteed by design.
- The leakage current measured on the \overline{RST} , \overline{SAL} , \overline{PFO} , and \overline{BLD} pins are tested with the output not asserted (output high impedance).
- When $V_{BAT} > V_{CC} > V_{SW}$, V_{OUT} remains connected to V_{CC} until V_{CC} drops below V_{SW} .
- When $V_{SW} > V_{CC} > V_{BAT}$, V_{OUT} remains connected to V_{CC} until V_{CC} drops below the battery voltage (V_{BAT}) – 75mV.
- Maximum external capacitive load on V_{REF} pin cannot exceed 1nF.
- The reset threshold tolerance is wider for V_{CC} rising than for V_{CC} falling due to the 10mV (typ) hysteresis, which prevents internal oscillation.

Table 7. Physical and environmental tamper detection levels

Sym	Parameter	Test conditions ⁽¹⁾	Min	Typ	Max	Unit
V _{HV}	Over voltage trip level		4.0	4.2	4.4	V
V _{LV}	Under voltage trip level		1.9	2.0	2.1	V
	$\overline{\text{SAL}}$ propagation delay time (after over/under voltage detection)	V _{HV} + 200mV or V _{LV} - 200mV		25	40	μs
V _{HTP}	Trip point for NH physical tamper input pins (TP ₁ or TP ₃)		V _{OUT} - 1.3 ⁽²⁾		V _{OUT} - 0.3 ⁽²⁾	V
V _{LTP}	Trip point for NL physical tamper input pins (TP ₂ or TP ₄)		0.3		1.0	V
	$\overline{\text{SAL}}$ propagation delay time ⁽³⁾ (after physical tamper pin detection)	V _{HTP} = V _{OUT} /V _{TPU} ; V _{LTP} = V _{SS} V _{DD} = 3.6		30	50	μs
	Physical tamper input (TP _X) glitch immunity			15		μs
T _H	Factory-programmed	I _{OUT} = 0mA	-5	80, 85, 95	+5	°C
T _L			-5	-25, -35	+5	°C
T _{HYST}	Temperature hysteresis			10		°C

- Valid for ambient operating temperature: T_A = -40 to 85°C; V_{CC} = V_{LV} to V_{HV} (except where noted). All Physical and Environmental Tamper functions are operational across the full temperature alarm range for STM1404.
- In the case of STM1404A, Physical Tamper input pins (TP_X) are referenced to V_{OUT} (Pin 12). In the case of STM1404B or C, TP_X are referenced to V_{TPU} pin (Pin 9).
- V_{CC} = V_{RST} (max) to 3.6V

Figure 28. Temperature hysteresis

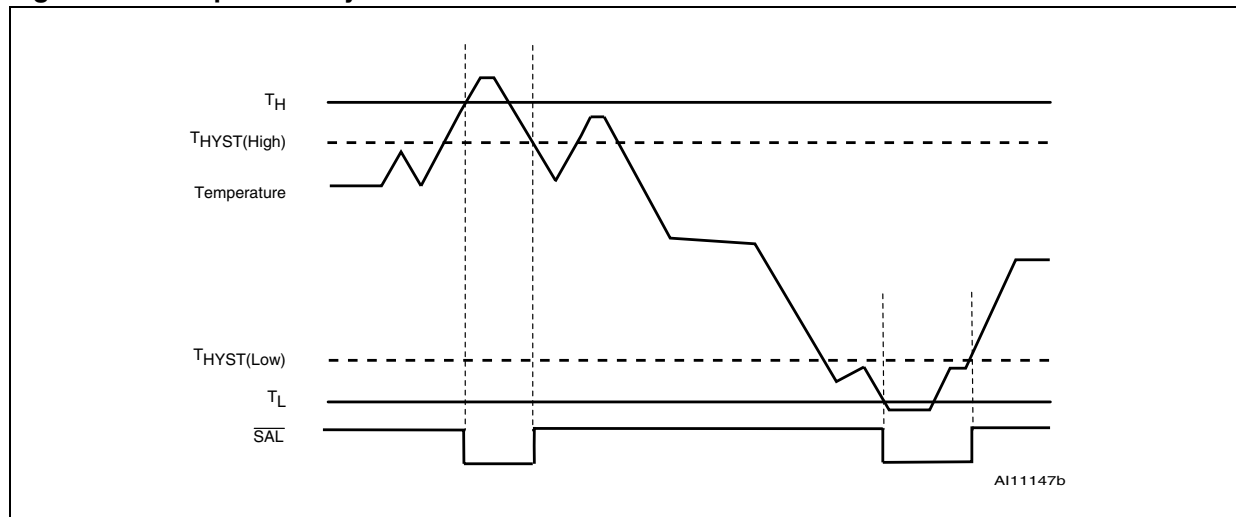

Package mechanical data

Figure 29. QFN16 – 16-lead, quad, flat package, no lead, 3x3mm body size, outline

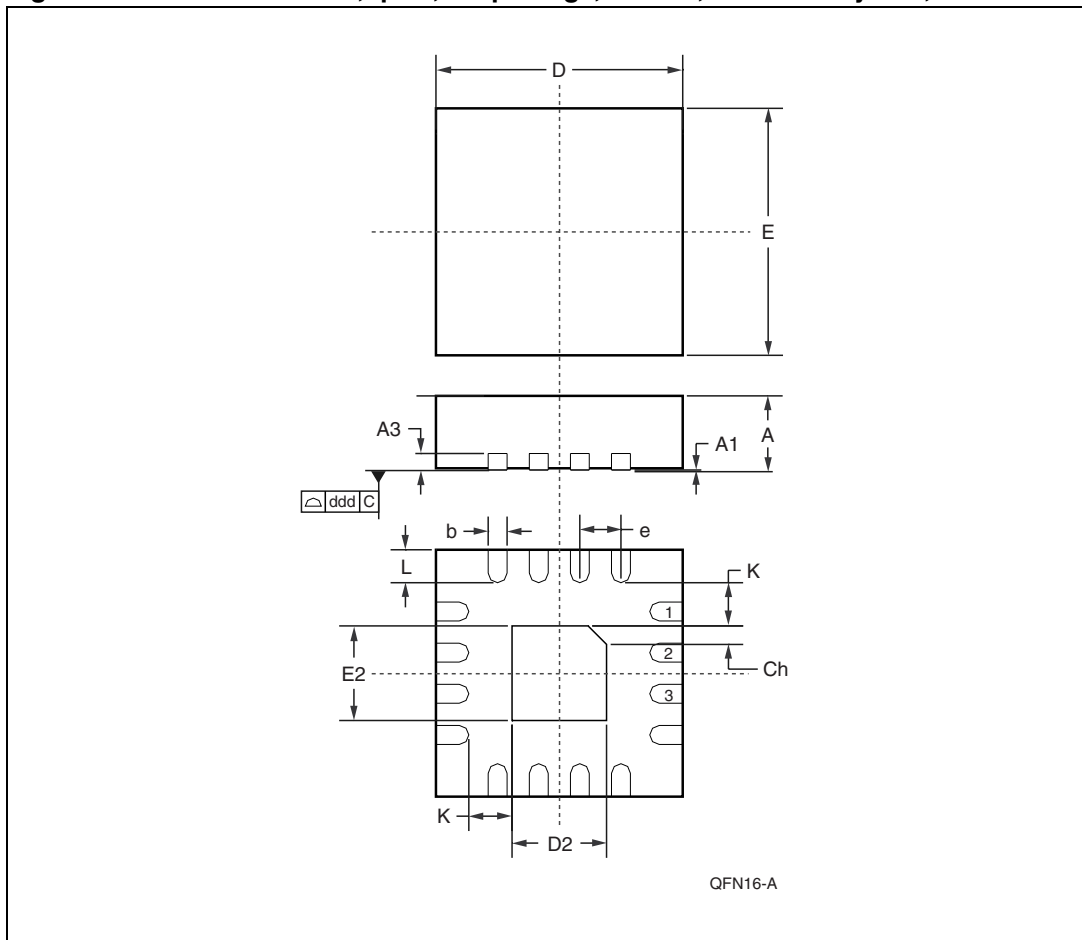

Note: Drawing is not to scale.

Table 8. QFN16 – 16-lead, quad, flat package, no lead, 3x3mm body size mechanical data

Symb	mm			inches		
	Typ	Min	Max	Typ	Min	Max
A	0.90	0.80	1.00	0.035	0.032	0.039
A1	0.02	0.00	0.05	0.001	0.000	0.002
A3	0.20	–	–	0.008	–	–
b	0.25	0.18	0.30	0.010	0.007	0.012
D	3.00	2.90	3.10	0.118	0.114	0.122
D2	1.70	1.55	1.80	0.067	0.061	0.071
E	3.00	2.90	3.10	0.118	0.114	0.122
E2	1.70	1.55	1.80	0.067	0.061	0.071
e	0.50	–	–	0.020	–	–
K	0.20	–	–	0.008	–	–
L	0.40	0.30	0.50	0.016	0.012	0.020
ddd	–	0.08	–	–	0.003	–
Ch	–	0.33	–	–	0.013	–
N	16			16		

Figure 30. QFN16 – 16-lead, quad, flat package, no lead, 3x3mm, recommended

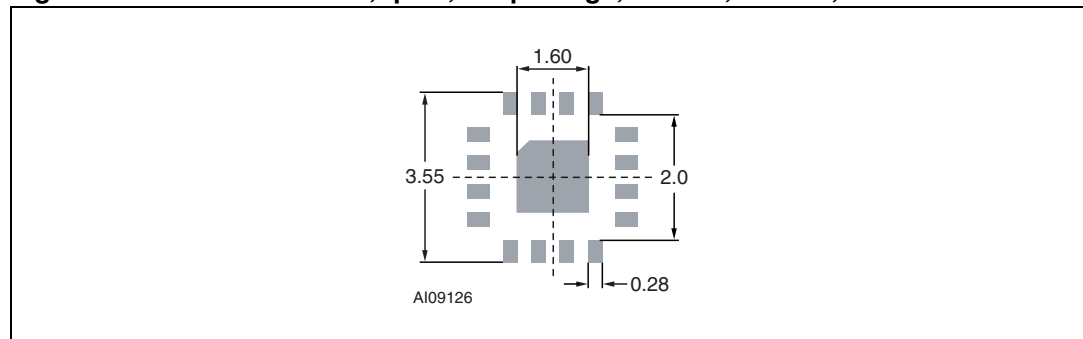

footprint

Note: Substrate pad should be tied to V_{SS}.

Part numbering

Table 9. Ordering information scheme (see [Figure 31 on page 34](#) for marking information)

Example:	STM1404	A	T	M	D	Q	6	F
Device type								
STM1404: over/under temperature detect								
V_{OUT} status ($\overline{\text{SAL}}$ = active-low)								
A: V _{OUT} = ON; $\overline{\text{Vccsw}}$ = normal mode								
B ⁽¹⁾ : V _{OUT} = high-Z; $\overline{\text{Vccsw}}$ = high								
C: V _{OUT} = ground; $\overline{\text{Vccsw}}$ = high								
Reset threshold voltage								
T: V _{RST} = 3.00V to 3.15V								
S: V _{RST} = 2.85V to 3.00V								
R: V _{RST} = 2.55V to 2.70V								
Battery low voltage detect threshold (V_{DET})								
M: V _{DET} = 2.3V (Typ)								
N: V _{DET} = 2.5V (Typ)								
O: V _{DET} = 3.2V (Typ)								
Under (TL)/over (TH) temperature alarm thresholds (STM1404 only)								
B: -25/+80°C H: -35/+80°C								
C: -25/+85°C I: -35/+85°C								
D: -25/+95°C J: -35/+95°C								
Package								
Q = QFN16 (3mm x 3mm)								
Temperature range								
6 = -40 to 85°C								
Shipping method								
F = ECOPACK Package, Tape & Reel								

1. Contact local ST sales office for availability.

For other options, or for more information on any aspect of this device, please contact the ST sales office nearest you.

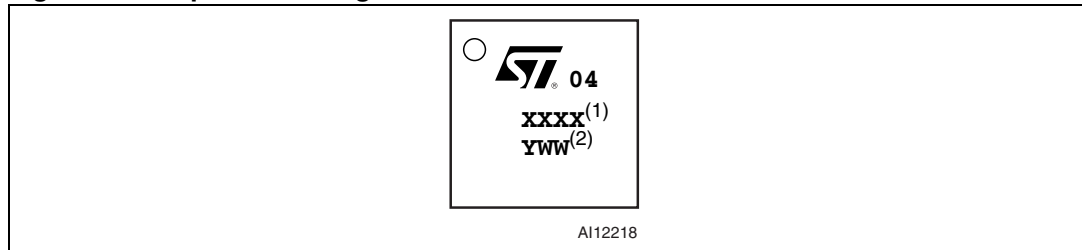
Figure 31. Topside marking information

1. Options codes:

X = A, B, or C (for V_{OUT})

X = T, S, or R (for Reset Threshold)

X = M, N, or O (for Battery Low Voltage Detect Threshold)

X = B, C, D, H, I, or J (for Temperature Alarm Threshold)

2. Traceability Codes

Y = Year

WW = Work Week

Revision history

Table 10. Document revision history

Date	Version	Description
11-Oct-2004	1.0	First Edition
26-Nov-2004	1.1	Corrected footprint dimensions; update characteristics (Figure 1, 2, 3, 4, 5, 6, 7, 8, 26, 27, 30 and Table 1, 2, 3, 6, 7).
22-Dec-2004	1.2	Update characteristics (Figure 4, Tables 6, 7, 9).
03-Feb-2005	1.3	Update characteristics (Figure 4, Tables 6, 7).
25-Feb-2005	1.4	Update temperature trip limits (Table 9)
06-May-2005	1.5	Update characteristics (Figure 3, 4, 28 and Table 6, 7).
05-Aug-2005	2.0	Removed STM1403 references (Figure 1, 2, 3, 4, 5, 6, 7, 8, 26, 27, 28 and Table 1, 2, 5, 6, 7, 9).
06-Jan-2006	3.0	Update status, characteristics, lead-free text, marking (Figure 4, 31 and Table 6, 7, 9).
08-Feb-2007	4.0	Update cover page, Figure 3: Block diagram, Table 7: Physical and environmental tamper detection levels, Figure 28: Temperature hysteresis, and part numbering (Table 9.)

Please Read Carefully:

Information in this document is provided solely in connection with ST products. STMicroelectronics NV and its subsidiaries ("ST") reserve the right to make changes, corrections, modifications or improvements, to this document, and the products and services described herein at any time, without notice.

All ST products are sold pursuant to ST's terms and conditions of sale.

Purchasers are solely responsible for the choice, selection and use of the ST products and services described herein, and ST assumes no liability whatsoever relating to the choice, selection or use of the ST products and services described herein.

No license, express or implied, by estoppel or otherwise, to any intellectual property rights is granted under this document. If any part of this document refers to any third party products or services it shall not be deemed a license grant by ST for the use of such third party products or services, or any intellectual property contained therein or considered as a warranty covering the use in any manner whatsoever of such third party products or services or any intellectual property contained therein.

UNLESS OTHERWISE SET FORTH IN ST'S TERMS AND CONDITIONS OF SALE ST DISCLAIMS ANY EXPRESS OR IMPLIED WARRANTY WITH RESPECT TO THE USE AND/OR SALE OF ST PRODUCTS INCLUDING WITHOUT LIMITATION IMPLIED WARRANTIES OF MERCHANTABILITY, FITNESS FOR A PARTICULAR PURPOSE (AND THEIR EQUIVALENTS UNDER THE LAWS OF ANY JURISDICTION), OR INFRINGEMENT OF ANY PATENT, COPYRIGHT OR OTHER INTELLECTUAL PROPERTY RIGHT.

UNLESS EXPRESSLY APPROVED IN WRITING BY AN AUTHORIZED ST REPRESENTATIVE, ST PRODUCTS ARE NOT RECOMMENDED, AUTHORIZED OR WARRANTED FOR USE IN MILITARY, AIR CRAFT, SPACE, LIFE SAVING, OR LIFE SUSTAINING APPLICATIONS, NOR IN PRODUCTS OR SYSTEMS WHERE FAILURE OR MALFUNCTION MAY RESULT IN PERSONAL INJURY, DEATH, OR SEVERE PROPERTY OR ENVIRONMENTAL DAMAGE. ST PRODUCTS WHICH ARE NOT SPECIFIED AS "AUTOMOTIVE GRADE" MAY ONLY BE USED IN AUTOMOTIVE APPLICATIONS AT USER'S OWN RISK.

Resale of ST products with provisions different from the statements and/or technical features set forth in this document shall immediately void any warranty granted by ST for the ST product or service described herein and shall not create or extend in any manner whatsoever, any liability of ST.

ST and the ST logo are trademarks or registered trademarks of ST in various countries.

Information in this document supersedes and replaces all information previously supplied.

The ST logo is a registered trademark of STMicroelectronics. All other names are the property of their respective owners.

© 2007 STMicroelectronics - All rights reserved

STMicroelectronics group of companies

Australia - Belgium - Brazil - Canada - China - Czech Republic - Finland - France - Germany - Hong Kong - India - Israel - Italy - Japan - Malaysia - Malta - Morocco - Singapore - Spain - Sweden - Switzerland - United Kingdom - United States of America

www.st.com