

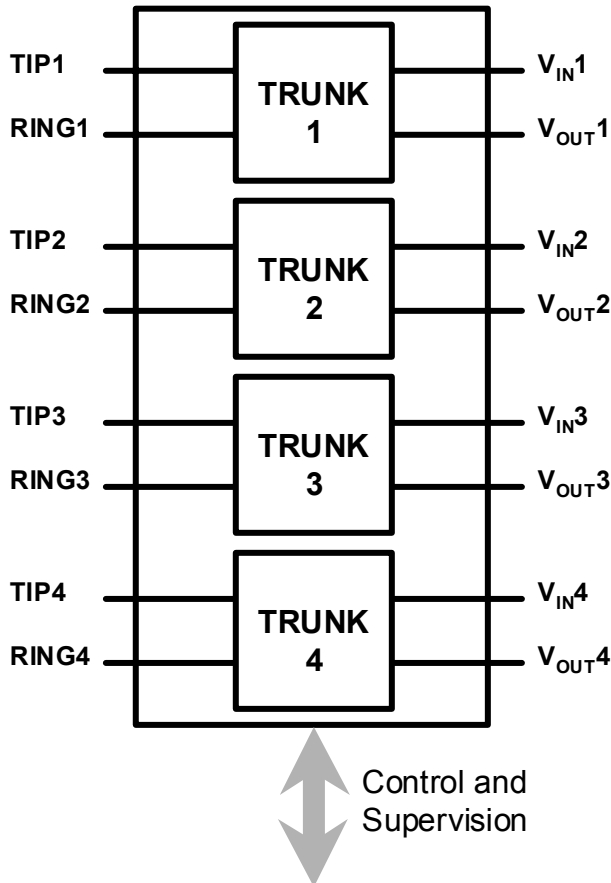

Ag2410

HIGH PERFORMANCE QUAD TRUNK



FEATURES

- 4 highly featured Trunks (COIC, FXO) in a single Module.
- Magnetic isolation providing high common mode rejection (CMRR) for use in un-grounded systems.
- Highly integrated with on board loop switch and integral diode bridge.
- Loop Start operation with On-Hook reception and reversal detect (for Caller Line ID and remote metering).
- Ringing detection and Loop Current detection.
- Meets requirements of EN60950/UL1950, and FCC Pt68.
- Minimum number of external components, single +5V system side power supply.
- Programmable d.c. mask.
- Silver Telecom "design-in" assistance.

DESCRIPTION

The Silver Telecom Ag2410 comprises four individual Trunk Circuits in a single Module. The combination of features and packaging offers extremely efficient use of board area, saving significantly on system size and cost.

The Ag2410 has been designed to work with 600R line impedance and meets international safety and regulatory requirements.

In addition to the features shown above the Ag2410 allows flexible programming of many functions, including the dc voltage mask.

Each circuit requires a minimum of external components and has been specified for ease of use, to reduce time to market.

The system interface has been designed for direct connection to popular Codecs of both the audio and signalling connections.

The Ag2410 is designed for applications where there is a high level of common mode interference, such as PABX, long loop applications and systems without a ground.

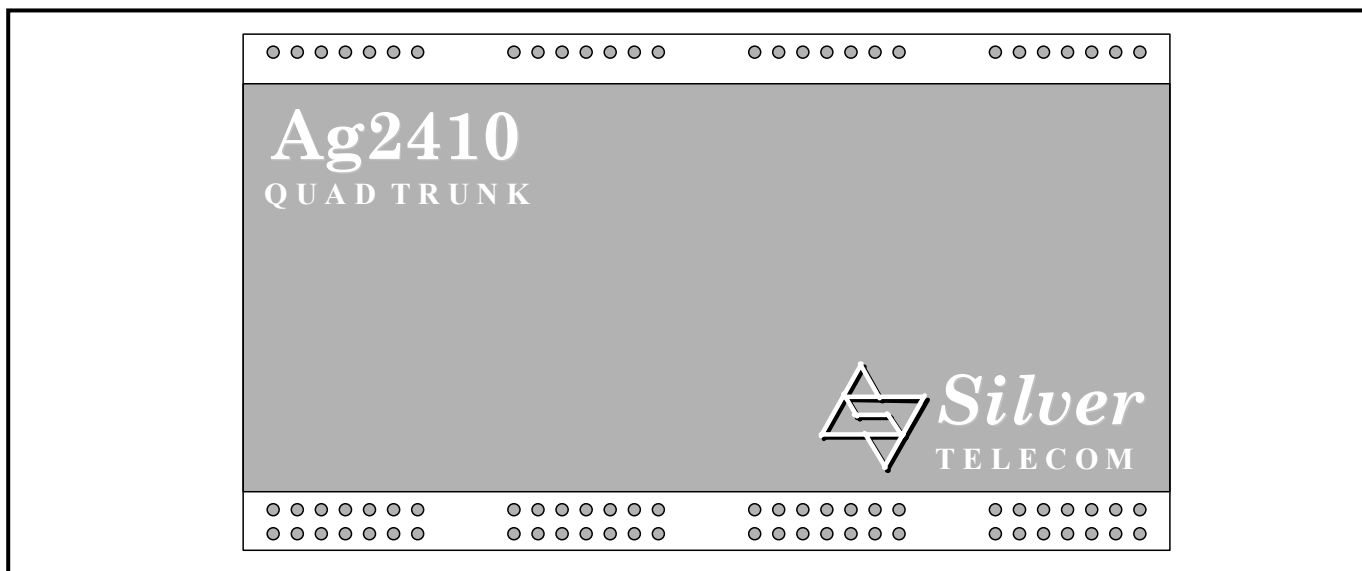

Figure 1: Packaging Format

Ordering Information

Ag2410 High Performance Quad Trunk

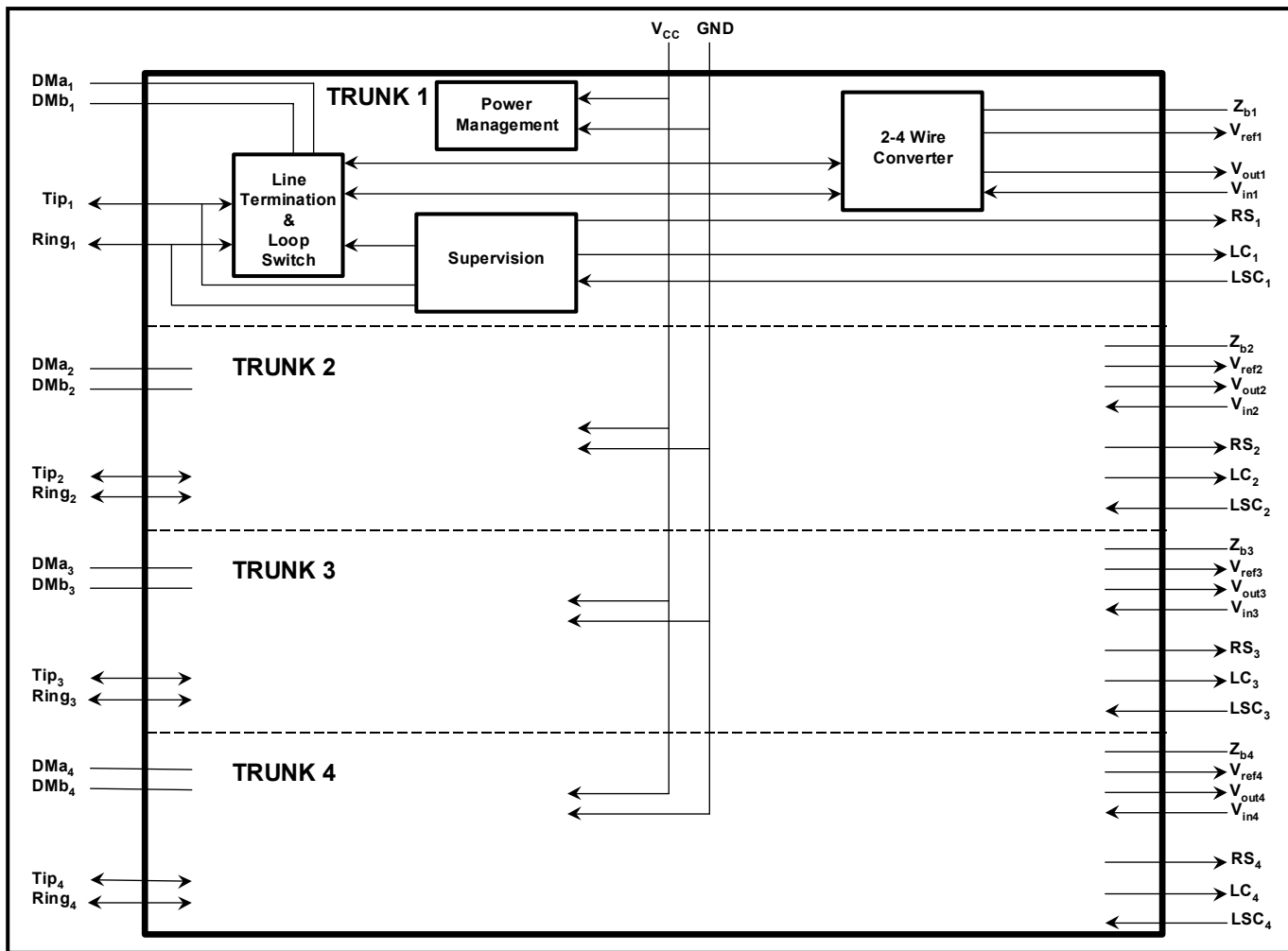

Figure 2: Block Diagram

1.0 Pin Description

Pin #				Name	Description
A	B	C	D		
1	8	15	22	TIP (A)	Tip. Connects to the subscriber line Tip.
2	9	16	23	RING (B)	Ring. Connects to the subscriber line Ring.
3	10	17	24	nc	No connect. This pin can be left open circuit.
4	11	18	25	nc	No connect. This pin can be left open circuit.
5	12	19	26	DMa	DC Mask a. A resistor is connected between this pin and DMb to adjust the d.c. characteristics of the termination.
6	13	20	27	DMb	DC Mask b. A resistor is connected between this pin and DMa to adjust the d.c. characteristics of the termination.
7	14	21	28	nc	No connect. This pin can be left open circuit.
71	57	43	29	GND	Analog ground. Normally connected to system ground. All four pins must be connected to Analog Ground.
72	58	44	30	V_{CC}	+5V supply. All four pins must be connected to +5V.
73	59	45	31	nc	No connect. This pin can be left open circuit.
74	60	46	32	nc	No connect. This pin can be left open circuit.
75	61	47	33	Z_b	Balance network. The network balance matching components are connected between this pin, V _{IN} and GND.
76	62	48	34	V_{IN}	Audio In. This is the analog input signal from the Codec (which is output on Tip and Ring). Connected via a 100nF capacitor.
77	63	49	35	nc	No connect. This pin can be left open circuit.
78	64	50	36	V_{OUT}	Audio Out. This is the analog output signal (from Tip and Ring) to the Codec. Connected via a 100nF capacitor.
79	65	51	37	nc	No connect. This pin can be left open circuit.
80	66	52	38	LC	Loop current. A logic 1 Indicates that loop current is flowing.
81	67	53	39	LSC	Loop switch control. Applying a logic 1 closes the integral loop switch.
82	68	54	40	RS	Ringing signal. A logic 0 indicates the presence of ringing voltage on the telephone line. Toggles at twice the ringing frequency. Also RS indicates whether the line polarity has reversed with a pulse.
83	69	55	41	nc	No connect. This pin can be left open circuit.
84	70	56	42	V_{REF}	Analog reference. Bias voltage for analog circuitry. Must be de-coupled with 100uF.

2.0 Line Interfacing

The line interfaces on the Ag2410 provide a flexible and robust interface to the telephone line. They are designed to meet regulatory standards whilst providing a space and power efficient solution.

2.1 D.C. Termination.

Any equipment terminating a telephone line must present the correct d.c. resistance to the line. This ensures that the correct current flows to be able to detect the off hook condition, avoids excessive power dissipation in the Subscriber Line Interface (SLIC) and the Subscriber's equipment and minimises the size of power supply needed to drive the SLIC.

The Ag2410 has been designed to meet the requirements of many network operators. This is done by making the d.c. characteristic adjustable. These are controlled by connecting the DM pins on the line side of the circuit. Table 1 shows how these are connected.

Table 1 Set Up of the DM Pins

Market	DMA	DMb
North America (EIA 464, Resistive)	Connect together through 270K resistor	
Europe (CTR21)	Connect together through 470K resistor	
Far East	Connect together through 270K resistor	

2.2 Signalling and Loop Status.

The Ag2410 provides facilities to monitor and control the telephone line. This allows the device to be used with a variety of loop signalling schemes and minimises the number of external components needed to implement a complete line interface.

2.2.1 The On-Board Loop Switch

The Ag2410 implements the loop start protocol when initiating and answering a call. This means that a switch must be closed to allow loop current to flow, signalling to the SLIC that the terminating equipment has gone "off-hook". This has been done historically by a relay. The Ag2410 uses an integral optically isolated switch to do this, eliminating the need for an external relay, so space and cost is saved for the user.

The On-Board Loop Switch is controlled by the LSC pin. A logic 1 applied to the pin closes the loop switch. This is done when the terminating equipment wishes to begin a call or in response to the reception of the ringing signal. The LSC pin can be controlled by the

output drive pins of a Codec or from a micro controller device.

Once the Loop Switch has been closed confirmation that loop current is flowing is provided by the LC pin. This can be used for fault detection and for call clear detection.

2.2.2 Ringing Detection and Sensitivity.

The terminal equipment must be capable of detecting and responding to an incoming call in the same way as a telephone set. The termination circuitry must, therefore, detect the presence of the ringing signal.

The Ag2410 provides an output, RS, which indicates the presence of ringing by switching from a logic 1 to logic 0. The RS output will toggle at twice the ringing frequency. A capacitor to ground can also be added if ringing cadence is needed rather than the ringing frequency.

The sensitivity to ringing is set internally to 20Vrms.

2.2.3 Reversal Detect

The ringing detect circuit will also detect DC polarity reversal at Tip/Ring. Since this is AC coupled only a pulse output (15mS min.) is given at the RS output at the instant of reversal.

An example of this type of signalling is in Caller Line ID in the United Kingdom, where a battery polarity reversal precedes the transmission of data before the ringing signal is applied to the line.

There must be greater than 30V across Tip and Ring for reversal detect to function correctly. This means that there is no detection when off-hook.

3.0 The 2-4 Wire (Hybrid) Conversion.

Each circuit on the Ag2410 module transmits and receives balanced 2-wire analog signals at the Tip and Ring connections. These are converted to a ground referenced output at V_{OUT} and from a ground referenced signal at V_{IN} .

V_{OUT} and V_{IN} are normally connected to a Codec (via d.c. blocking capacitors) for conversion to and from a Pulse Code Modulated (PCM) stream.

3.1 Transmit and Receive Gain.

The gain in both the transmit and receive directions is set at 0dB. Any gain adjustments can be made using the Codec functionality. This is either by hardware or software depending upon the Codec used.

Example	2-wire Impedance	Network Balance Impedance	Zbal1	Zbal2	Zbal3	C3	Notes
1	600Ω	600Ω	51K	36K	0Ω	47pF	Far East, Middle East
2	600Ω	AT&T compromise	33K	33K	15K	2700pF	North America
3	Other	Other	51K	36K	0Ω	47pF	Program impedance using "intelligent" codec (e.g. SICOF1 or QSLAC)

Table 2: Line and Network Balance Impedance Examples

3.2 The 2 Wire Impedance

The input impedance, Z_{IN} , of each circuit is set internally to 600R. To provide other impedances, use a codec where the internal filter characteristics can be programmed to provide the correct matching. In order to generate the filter coefficients a model of the Ag2410 must be used. This file, in .CIR format is available on request from Silver Telecom or one of our representatives.

Full details on how the Codec is programmed must be obtained from the Codec manufacturer.

3.3 Network Balance Impedance

The setting of the network balance can be done by programming of the Codec, using the .CIR file, or it can be done by hardware components.

If the hardware technique is used a network must be connected between Z_b and V_{in} . Common examples are shown in Table 2.

3.4 On-Hook Reception

The need to provide the facility for data exchange

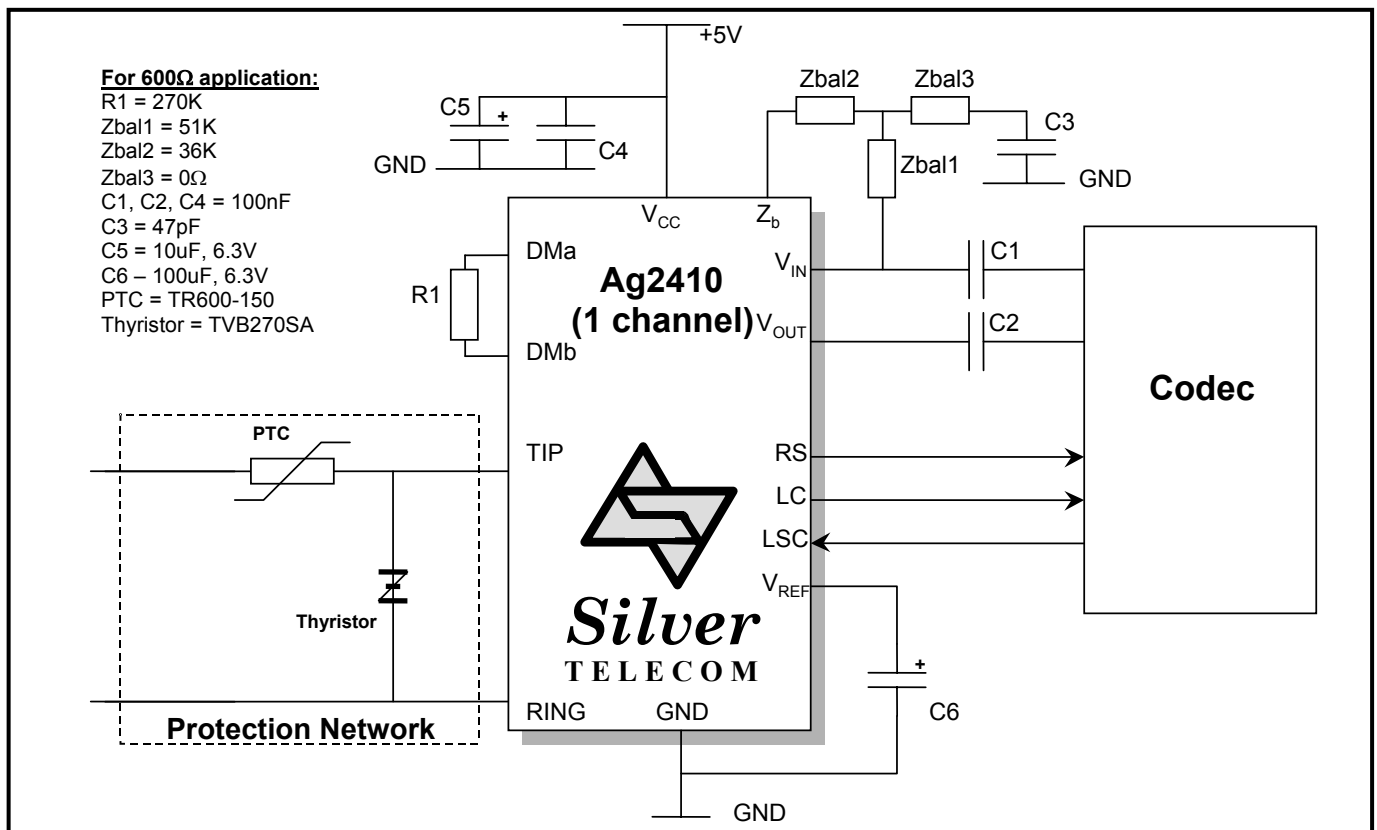

Figure 3: A Single Channel Showing Impedance and Protection Components

On-Hook is becoming increasingly common, whether for Caller Line I.D. or for telemetry purposes. The Ag2410 can receive signals On-Hook, presenting a high impedance to the line, i.e. while drawing a very small current (5µA approx) from the line.

3.5 Ringer Load Networks

The “dummy ringer” is usually a capacitive/resistive load which is connected across TIP/RING. During a call it is of sufficiently high impedance not to affect the operation of the interface. The dummy ringer is integral to the Ag2410, and is suitable for CTR21 (Europe), USA and Asia.

For other dummy ringer requirements not covered in this datasheet, please contact Silver Telecom, or their local representative.

4.0 Device Protection.

As with many of the requirements which must be met

by the Ag2410 the device protection is dependent upon regulatory standards in the market in which the equipment is deployed. Some examples are given below, but these are not exhaustive.

4.1 FCC Pt 68 Requirements.

To withstand the FCC Pt68 longitudinal voltage surge of 1500V no protection is required as the barrier will withstand 1500V peak voltage to GND.

To withstand the FCC Pt68 metallic surges at 800V requires a 130V AC varistor (which clamps at 300V which is the rating of the loop switch transistor). A 14mm device should be used to withstand the two 100A 10/560us surges.

Examples of suitable devices are:-

- Joyin JVR-14N201K;
- Walsin VZ14D201KBS

Note: If varistors to ground are used for added protection (e.g. more than 1500V may be seen in the

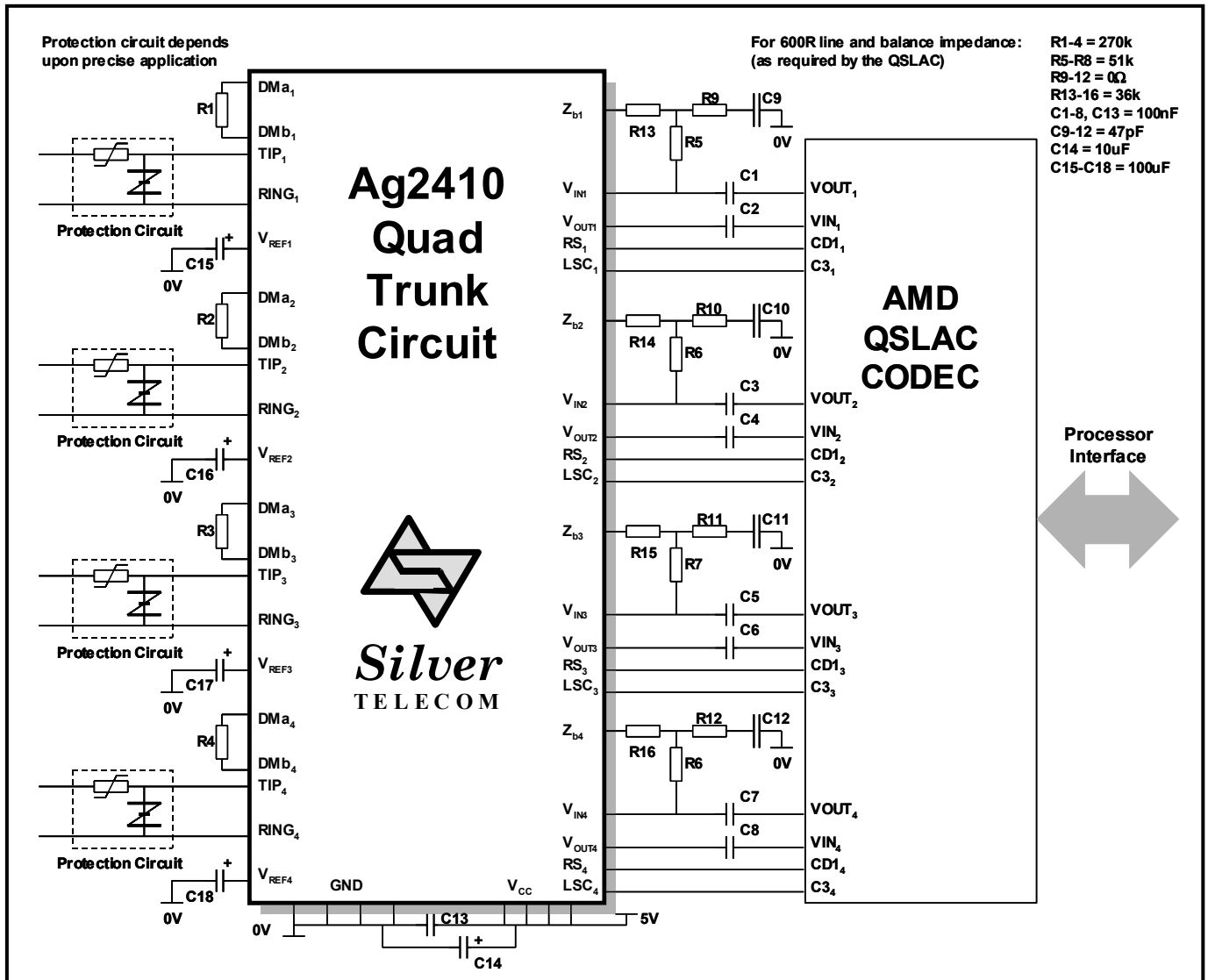

Figure 4: A 4 Channel Circuit Using the AMD QSLAC

field) customers should be aware that the FCC test generator for longitudinal tests is rated at up to 1000A. 10 Ω 2W wire wound surge limiting resistors will also be needed.

4.2 UL1459 and UL1950 Protection.

To meet the UL1459 and UL1950 mains cross test 22 Ω 2W wire wound surge resistors and 0.35A special fuses (Bussman C515 or Littelfuse 220003) in a balanced configuration are required. Alternatively a Teccor F1250T fuse may be used without surge limiting resistors.

It is also possible to use PTC thermistors to meet these tests. The Raychem TR600-150 is designed for this application. See Raychem application notes for further details.

4.3 Other Standards.

For general mains cross protection (CCITT K21), a 47 Ω 2W wire wound surge resistor and a PTC thermistor are sufficient. A suitable device is the Walsin PTD3A350H26. (Metallic protection with a single device is all that is required as the Ag2410 will withstand longitudinal voltages up to 1000Vrms to ground without additional protection).

5.0 Regulatory Standards

There are some aspects of international standards which are not fully met by the Ag2410. These are shown below. It is Silver Telecom's policy to bring to the attention of customers all known exceptions.

The Ag2410 meets the requirements of EN60950 (1992) paragraph 6.2.1.2 for all countries except Norway and Sweden. Please contact Silver Telecom if the product is needed for Norway or Sweden.

User/Network safety from mains power voltage (UL1950/EN60950 paragraphs 2.1.1 and 6.2.1.4) must be provided externally by a power supply with reinforced or double insulation.

6.0 Layout

Signal tracks should be kept as short as possible. Special attention should be paid to Dma, DMb and Zb, as these are sensitive nodes.

7.0 Absolute Maximum Ratings*

All Voltages are with respect to ground unless otherwise stated.

	Parameter	Sym	Min	Max	Units
1	DC supply voltage	V _{CC}	-0.3	6.0	V
2	DC battery voltage present between Tip and Ring (on-hook)	V _{TR}		300	V
3	Maximum voltage on programmable pin, LSC		-0.3	6.0	V
4	Maximum power dissipation per trunk @ 25°C	P _{TRU NK}		0.75	W
5	Maximum power dissipation per module @ 25°C	P _{TOT}		3.0	W
6	Maximum loop current (continuous)	I _{LOOP}		100	mA
7	Maximum ring trip current (for 1 second)	I _{RING}		185	mA
8	Storage Temperature	T _S	-40	+100	°C

*Exceeding the above ratings may cause permanent damage to the product. Functional operation under these conditions is not implied. Maximum ratings assume free air flow.

8.0 Recommended Operating Conditions*

All Voltages are with respect to ground unless otherwise stated.

	Parameter	Symbol	Min	Typ	Max	Units
1	DC supply voltage	V _{CC}	4.75	5.0	5.25	V
2	DC battery voltage on Tip and Ring (on-hook)	V _{TIP}	0	0	-120	V
		V _{RING}	0	-48	-120	V
3	DC loop current	I _{LOOP}	0	25	85	mA
4	Operating Temperature	T _{OP}	0	25	70	°C

*Typical figures are at 25 °C with nominal +5V supplies and are for design use only.

9.0 DC Electrical Characteristics.

	Characteristic	Sym	Min	Typ ²	Max	Units	Test Comments ¹
1	Supply current (per trunk), on-hook ³	I _{CC}		4.0	6.0	mA	
2	Power consumption, on-hook	P _{TOT}		20.0	80.0	mW	
3	Loop current range	I _{LOOP}	14.0		85.0	mA	
4	Status outputs, RS, LC Output low voltage Output high voltage	V _{OL} V _{OH}	3.5		0.4	V V	@ 50µA @ -50µA
5	Control input, LSC Input low voltage Input high voltage	V _{IL} V _{IH}	4.0		0.3	V V	
6	Control input, LSC Input low current Input high current	I _{IL} I _{IH}			10 2.0	µA mA	
7	Off-hook DC voltage			5.7		V	I _{LOOP} = 20mA DMA-DMb=270k
8	Leakage current, Tip and Ring to analog ground	I _{LA}			10	µA	100V _{DC}
9	Leakage current on-hook, Tip to Ring	I _{LTR}			10	µA	100V _{DC}

All DC Electrical Characteristics are over the Recommended Operating Conditions with V_{CC} at +5.0V ±5%, unless otherwise stated.

¹ For test circuit details please contact Silver Telecom

² Typical figures are at 25°C with nominal +5V supply and 25mA loop current, unless otherwise stated. These figures are for design aid only.

³ Operating currents are dependant on the users application.

10.0 AC Electrical Characteristics.

	Characteristic	Sym	Min	Typ*	Max	Units	Test Comments ¹
1	Ringing voltage: detect Ringing voltage: no detect	V_{RD}	28	20 20	14	V_{RMS}	
2	Ringing frequency	F_R	15		68	Hz	
3	Input Impedance at V_{IN}			100		k Ω	
4	Output impedance at V_{out}				10		
5	Absolute voltage gain, 2 Wire to V_{OUT}		-0.5		+0.5	dB	Off-hook
6	Absolute voltage gain, V_{IN} to 2 Wire		-0.5		+0.5	dB	Off-Hook
7	On-hook gain, 2 Wire to V_{OUT}		-1.5		-0.5	dB	
8	Relative gain, referenced to 1kHz. 2Wire - V_{out} , V_{in} - 2Wire		-0.5		+0.5	dB	300 - 3400 Hz
9	Total harmonic distortion @ 2Wire and V_{out}	THD		0.1	1.0	%	@0dBm, 1kHz
10	Overload distortion @2 Wire and V_{out}	OD		0.5	5.0	%	@+3dBm, 1kHz
11	Common mode rejection ratio	CMRR	70	75		dB	50 – 500Hz $V_{CM} = 60V_{RMS}$
12	Common mode overload level	CMOL		250	300	V_{RMS}	50 – 60Hz
13	Idle channel noise off-hook	N_C		0	12	dBrnC	@2 Wire & V_{OUT}
14	CMRR on-hook		40	55		dB	50-500Hz
15	CMOL on-hook			70 40		V_{rms} V_{rms}	+5V supply +3.3 supply
16	Idle channel noise	N_C		12.0		dBrnC	@2 Wire & V_{OUT}
17	Power supply rejection ratio at 2 Wire and V_{out}	PSRR	25			dB	Ripple 0.1V, 1kHz on V_{CC}
18	Return loss	RL	18			dB	300-3400Hz
19	Transhybrid loss	THL	18 21			dB dB	300 - 3400Hz 500 - 2500Hz
20	Metallic to longitudinal balance		60 40	70 70		dB	200-1000Hz 1000-4000Hz
21	Polarity reversal detect pulse		5	30		mS	>30V at T/R
22	Crosstalk			-70		dB	1kHz, 0dBm
23	Leakage current, Tip or Ring to analog ground	I_{LA}			5	mA_{RMS}	1000V ac

All AC Electrical Characteristics are over the Recommended Operating Conditions with V_{CC} at +5.0V \pm 5%, unless otherwise stated.

*Typical figures are at 25°C with nominal 5V supply and 25mA loop current unless otherwise stated. These figures are for design aid only.

¹For test circuit details please contact Silver Telecom.

11.0 Mechanical Specification and Pin Assignment

