

CAT. NO. & DIMENSIONS

| NO. OF CONTACTS (n) | CAT. NO.       | DIMENSIONS (NOTE2) |         |         |         |
|---------------------|----------------|--------------------|---------|---------|---------|
|                     |                | A ± 0.2            | B ± 0.2 | C ± 0.2 | D ± 0.1 |
| 4                   | SFW4R-3/4ST__  | 9.8                | 8.6     | 3.0     | 3.92    |
| 5                   | SFW5R-3/4ST__  | 10.8               | 9.6     | 4.0     | 4.92    |
| 6                   | SFW6R-3/4ST__  | 11.8               | 10.6    | 5.0     | 5.92    |
| 7                   | SFW7R-3/4ST__  | 12.8               | 11.6    | 6.0     | 6.92    |
| 8                   | SFW8R-3/4ST__  | 13.8               | 12.6    | 7.0     | 7.92    |
| 9                   | SFW9R-3/4ST__  | 14.8               | 13.6    | 8.0     | 8.92    |
| 10                  | SFW10R-3/4ST__ | 15.8               | 14.6    | 9.0     | 9.92    |
| 11                  | SFW11R-3/4ST__ | 16.8               | 15.6    | 10.0    | 10.92   |
| 12                  | SFW12R-3/4ST__ | 17.8               | 16.6    | 11.0    | 11.92   |
| 13                  | SFW13R-3/4ST__ | 18.8               | 17.6    | 12.0    | 12.92   |
| 14                  | SFW14R-3/4ST__ | 19.8               | 18.6    | 13.0    | 13.92   |
| 15                  | SFW15R-3/4ST__ | 20.8               | 19.6    | 14.0    | 14.92   |
| 16                  | SFW16R-3/4ST__ | 21.8               | 20.6    | 15.0    | 15.92   |
| 17                  | SFW17R-3/4ST__ | 22.8               | 21.6    | 16.0    | 16.92   |
| 18                  | SFW18R-3/4ST__ | 23.8               | 22.6    | 17.0    | 17.92   |
| 19                  | SFW19R-3/4ST__ | 24.8               | 23.6    | 18.0    | 18.92   |
| 20                  | SFW20R-3/4ST__ | 25.8               | 24.6    | 19.0    | 19.92   |
| 21                  | SFW21R-3/4ST__ | 26.8               | 25.6    | 20.0    | 20.92   |
| 22                  | SFW22R-3/4ST__ | 27.8               | 26.6    | 21.0    | 21.92   |
| 23                  | SFW23R-3/4ST__ | 28.8               | 27.6    | 22.0    | 22.92   |
| 24                  | SFW24R-3/4ST__ | 29.8               | 28.6    | 23.0    | 23.92   |
| 25                  | SFW25R-3/4ST__ | 30.8               | 29.6    | 24.0    | 24.92   |
| 26                  | SFW26R-3/4ST__ | 31.8               | 30.6    | 25.0    | 25.92   |
| 27                  | SFW27R-3/4ST__ | 32.8               | 31.6    | 26.0    | 26.92   |
| 28                  | SFW28R-3/4ST__ | 33.8               | 32.6    | 27.0    | 27.92   |
| 29                  | SFW29R-3/4ST__ | 34.8               | 33.6    | 28.0    | 28.92   |
| 30                  | SFW30R-3/4ST__ | 35.8               | 34.6    | 29.0    | 29.92   |

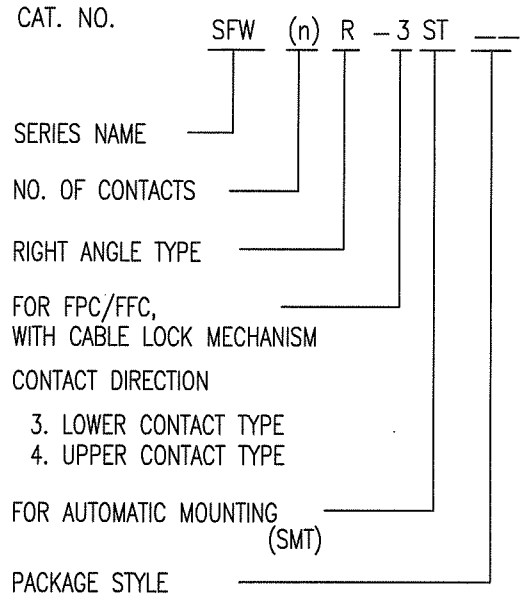

NOTES

1. THIS PRODUCT IS THE CONNECTOR USED FOR FPC/FFC AND COPE WITH AUTOMATIC MOUNTING (SMT).
2. SEE PART DRAWINGS FOR DIMENSIONS A~D.
3. THIS PRODUCT IS THE CONNECTOR WITH CABLE LOCK MECHANISM.

|                          |  |            |  |  |  |            |  |   |  |         |  |
|--------------------------|--|------------|--|--|--|------------|--|---|--|---------|--|
| mat'l. code              |  |            |  | surface 58 / tolerance ISO 1302 / ISO 406 / ISO 1101 |  | projection |  | product family 58RF   |  | CODE JP |  |
| ltr ecn no dr date       |  |            |  | tolerances unless otherwise specified                |  | mm         |  | title   |  |         |  |
| A J06-0398 H.T 9/26/06   |  |            |  | angles linear  |  | mm         |  | CAT NO. TABLE FOR 1mm SPACING SMT CONNECTOR (Cat. No. SFW__R-3/4ST__) |  |         |  |
| B J09-0363 M.Y 2009-10-8 |  |            |  |  |  | scale X    |  | dwg no sheet 1 of 1 size  |  |         |  |
|                          |  |            |  | dr M.YAMASHITA 2009-10-8                             |  | FCJ        |  | JSA 93206 A4  |  |         |  |
|                          |  |            |  | enr M.YAMASHITA 2009-10-8                            |  |            |  | type Product Customer Drawing   |  |         |  |
|                          |  |            |  | chr S. With 2009-10-8                                |  |            |  |   |  |         |  |
|                          |  |            |  | appd S. Chelam 2009-10-8                             |  |            |  |   |  |         |  |
| sheet index              |  | revision B |  | sheet 1  |  |            |  |   |  | Rev. B  |  |

SC-SFW05 JSA93207 93208 93209 93210 93211 93212 93213 form: A4