

48V Input	100V Transient Input	15V Output	3.3A Current	2000Vdc Isolation	Eighth-brick DC-DC Converter
---------------------	--------------------------------	----------------------	------------------------	-----------------------------	--

The PowerQor® Eighth-brick series is composed of next generation, board-mountable, isolated, fixed switching frequency dc/dc converters that use synchronous rectification to achieve extremely high power conversion efficiency. The power dissipated by the converter is so low that a heatsink is not required, which saves cost, weight, height, and application effort. All of the power and control components are mounted to the multi-layer PCB substrate with high-yield surface mount technology. Since the PowerQor converter has no explicit thermal interfaces, it is extremely reliable. RoHS Compliant (See page 15).

PowerQor®



PQ60150EKA03
Module

Operational Features

- High efficiency, 87% at full rated load current
- Delivers up to 50W of output power with minimal derating - no heatsink required
- Operating input voltage range: 35V-75Vdc, with 100V, 100ms input voltage transient capability
- Fixed frequency switching provides predictable EMI performance
- No minimum load requirement means no preload resistors required

Mechanical Features

- Industry standard eighth-brick pin-out configuration
- Size: 0.9" x 2.3" (22.9 x 58.4mm)
- Low Profile total height only 0.340" (8.64mm), permits better airflow and smaller card pitch
- Total weight: 0.85oz (24g)
- Flanged pins designed to permit surface mount soldering (avoid wave solder) using FPIP technique

Control Features

- On/Off control referenced to input side (positive and negative logic options are available)
- Remote sense for the output voltage compensates for output distribution drops
- Output voltage trim permits custom voltages and voltage margining

Safety Features

- 2000V, 30MΩ input-to-output isolation provides input/output ground separation
- UL 60950-1:2003 File #E194341, Basic Insulation
- CAN/CSA-C22.2 No. 60950-1:2003
- EN60950-1:2001, Certified by TÜV

Protection Features

- Input under-voltage lockout disables converter at low input voltage conditions
- Output current limit and short circuit protection protects converter and load from permanent damage and consequent hazardous conditions
- Active back bias limit prevents damage to converter from external load induced pre-bias
- Output over-voltage protection protects load from damaging voltages
- Thermal shutdown protects converter from abnormal environmental conditions

Contents

	Page No.
Mechanical Drawing - Open frame - EKA & EKL (low Profile)	2
Mechanical Drawing - Encased	3
PQ60150EKx03 Electrical Characteristics	4-5
PQ60150EKx03 Standards & Qualification Testing.	6
PQ60150EKx03 Figures	7-10
Application Section	11-14
Ordering Information	15

MECHANICAL DRAWING - OPEN FRAME - EKA & EKL (LOW PROFILE)

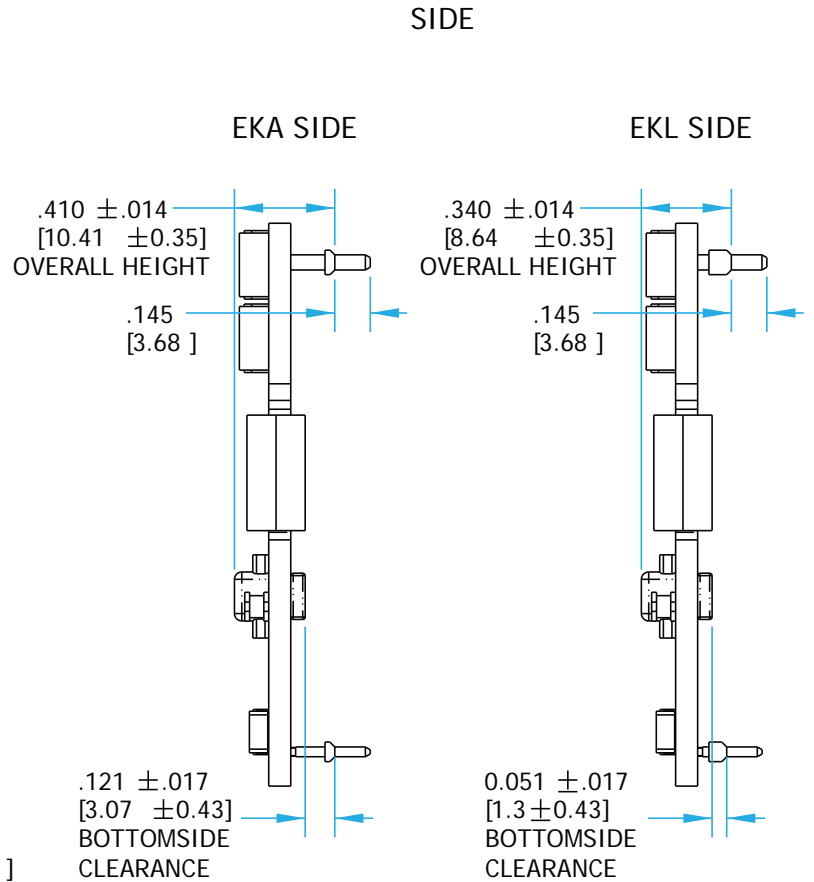
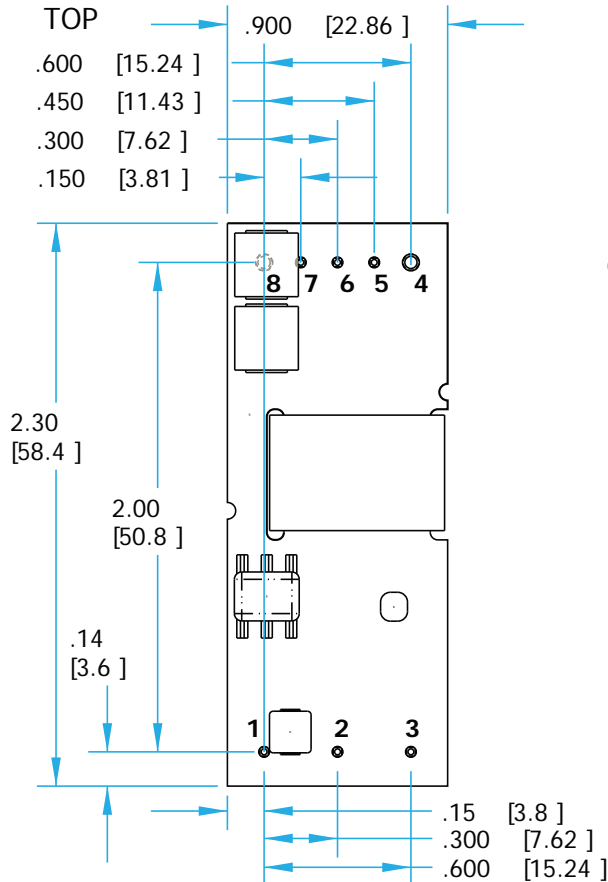

NOTES

- 1) Pins 1-3, 5-7 are 0.040" (1.02mm) diameter, with 0.080" (2.03mm) diameter standoff shoulders.
- 2) Pins 4 and 8 are 0.062" (1.57 mm) diameter with 0.100" (2.54 mm) diameter standoff shoulders.
- 3) Other pin extension lengths available. Recommended pin length is 0.03" (0.76mm) greater than the PCB thickness.
- 4) All Pins: Material - Copper Alloy- Finish (RoHS 6/6) - Matte Tin over Nickel plate
- 5) Undimensioned components are shown for visual reference only.
- 6) All dimensions in inches (mm) Tolerances: x.xx +/-0.02 in. (x.x +/-0.5mm) x.xxx +/-0.010 in. (x.xx +/-0.25mm)
- 7) Weight: 0.85 oz (24 g) typical
- 8) Workmanship: Meets or exceeds IPC-A-610C Class II
- 9) The flanged pins are designed to permit surface mount soldering (allowing to avoid the wave soldering process) through the use of the flanged pin-in-paste technique.
- 10) UL/TUV standards require a clearance greater than 0.04" (1.02mm) between input and output for Basic insulation. This issue should be considered if any copper traces are on the top side of the user's board. Note that the ferrite core shown at left above is considered part of the input/primary circuit.

PIN DESIGNATIONS

Pin	Name	Function
1	Vin(+)	Positive input voltage
2	ON/OFF	TTL input to turn converter on and off, referenced to Vin(-), with internal pull up.
3	Vin(-)	Negative input voltage
4	Vout(-)	Negative output voltage
5	SENSE(-)	Negative remote sense ¹
6	TRIM	Output voltage trim ²
7	SENSE(+)	Positive remote sense ³
8	Vout(+)	Positive output voltage

Notes:

- 1) SENSE(-) should be connected to Vout(-) either remotely or at the converter.
- 2) Leave TRIM pin open for nominal output voltage.
- 3) SENSE(+) should be connected to Vout(+) either remotely or at the converter.

MECHANICAL DRAWING - ENCASED

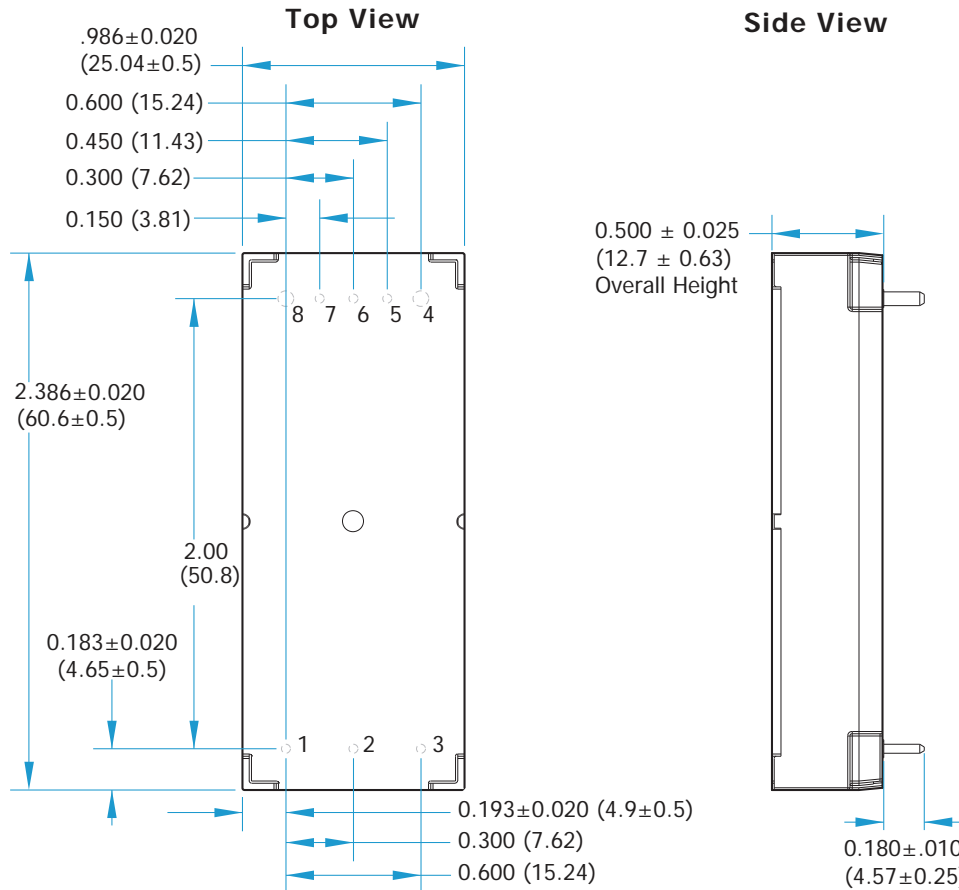

NOTES

- 1) Pins 1-3, 5-7 are 0.040" (1.02mm) diameter, with 0.080" (2.03mm) diameter standoff shoulders.
- 2) Pins 4 and 8 are 0.062" (1.57 mm) diameter with 0.100" (2.54 mm) diameter standoff shoulders.
- 3) Other pin extension lengths available. Recommended pin length is 0.03" (0.76mm) greater than the PCB thickness.
- 4) All Pins: Material - Copper Alloy- Finish (RoHS 6/6) - Matte Tin over Nickel plate
- 5) Undimensioned components are shown for visual reference only.
- 6) All dimensions in inches (mm) Tolerances: x.xx +/-0.02 in. (x.x +/-0.5mm) x.xxx +/-0.010 in. (x.xx +/-0.25mm)
- 7) Weight: 5 oz (142 g) typical
- 8) Workmanship: Meets or exceeds IPC-A-610C Class II
- 9) The flanged pins are designed to permit surface mount soldering (allowing to avoid the wave soldering process) through the use of the flanged pin-in-paste technique.

PIN DESIGNATIONS

Pin	Name	Function
1	Vin(+)	Positive input voltage
2	ON/OFF	TTL input to turn converter on and off, referenced to Vin(-), with internal pull up.
3	Vin(-)	Negative input voltage
4	Vout(-)	Negative output voltage
5	SENSE(-)	Negative remote sense ¹
6	TRIM	Output voltage trim ²
7	SENSE(+)	Positive remote sense ³
8	Vout(+)	Positive output voltage

Notes:

- 1) SENSE(-) should be connected to Vout(-) either remotely or at the converter.
- 2) Leave TRIM pin open for nominal output voltage.
- 3) SENSE(+) should be connected to Vout(+) either remotely or at the converter.



Technical Specification

Input: 35-75V
Output: 15V
Current: 3.3A
Part No.: PQ60150EKx03

PQ60150EKx03 Electrical Characteristics

Ta = 25°C, airflow rate=300LFM, Vin=48V dc unless otherwise noted; full operating temperature range is -40°C to +100°C baseplate temperature with appropriate power derating. Specifications subject to change without notice.

Parameter	Min.	Typ.	Max.	Units	Notes & Conditions
ABSOLUTE MAXIMUM RATINGS					
Input Voltage					
Non-Operating			100	V	Continuous
Operating	35		75	V	Continuous
Operating Transient Protection			100	V	100ms transient, square wave
Isolation Voltage					
Input to Output			2000	V dc	Basic Insulation
Operating Temperature	-40		100	°C	
Storage Temperature	-55		125	°C	
Voltage at ON/OFF input pin	0		13.5	V	
INPUT CHARACTERISTICS					
Operating Input Voltage Range	35	48	75	V	
Input Under-Voltage Lockout					
Turn-On Voltage Threshold	33.0	34.0	35.0	V	
Turn-Off Voltage Threshold	31.5	32.3	33.5	V	See Note 1
Lockout Voltage Hysteresis	1.2	1.7	2.2	V	
Maximum Input Current			1.7	A	100% Load, 35V Vin, nominal Vout
No-Load Input Current		75		mA	
Disabled Input Current		7.5		mA	
Inrush Current Transient Rating			0.005	A ² s	
Response to Input Transient		320		mV	1000V/ms input transient
Input Reflected Ripple Current		1.5		mA	RMS thru 10µH inductor; Figures 13 & 15
Input Terminal Ripple Current		36		mA	RMS; Figures 13 & 14
Recommended Input Fuse			20	A	Fast acting external fuse recommended
Recommended External Input Capacitance		47		µF	Typical ESR 0.1-0.2Ω; Figure 13
Input Filter Component Values (L/C)		1/2.35		µH/µF	Internal values; see Figure E
OUTPUT CHARACTERISTICS					
Output Voltage Set Point	14.85	15	15.15	V	
Output Voltage Regulation					
Over Line		±0.1/15		%/mV	
Over Load		±0.15/22.5		%/mV	
Over Temperature	-375		375	mV	
Total Output Voltage Range	14.55	15.0	15.45	V	Over sample, line, load, temperature & life
Output Voltage Ripple and Noise					20MHz bandwidth; see Note 2
Peak-to-Peak		75		mV	Full load; see Figure 13 & 16
RMS		14		mV	Full load; see Figure 13 & 16
Operating Output Current Range	0.0		3.3	A	Subject to thermal derating; Figures 5 - 8
Output DC Current-Limit Inception	3.6	4.2		A	nominal Vout
Output DC Current-Limit Shutdown Voltage		13.5		V	
Back-Drive Current Limit while Enabled		3.2		A	Negative current drawn from output
Back-Drive Current Limit while Disabled		5		mA	Negative current drawn from output
Maximum Output Capacitance Electrolytic			1	mF	Nominal Vout at half load (resistive load)
EFFICIENCY					
100% Load		87		%	Figures 1 - 4
50% Load		84		%	Figures 1 - 4

PQ60150EKx03 Electrical Characteristics (Continued)

Ta=25°C, airflow rate=300LFM, Vin=48V dc unless otherwise noted; full operating temperature range is -40°C to +100°C baseplate temperature with appropriate power derating. Specifications subject to change without notice.

Parameter	Min.	Typ.	Max.	Units	Notes & Conditions
DYNAMIC CHARACTERISTICS					
Input Voltage Ripple Rejection		55		dB	120Hz
Output Voltage during Load Current Transient					See Note 3
Step Change in Output Current (0.1A/μs)		320		mV	50% to 75% to 50% Iout max; Figure 11
Step Change in Output Current (1A/μs)		130		mV	50% to 75% to 50% Iout max; Figure 12
Settling time		150		μs	To within 1% Vout nom
Turn-On Transient					
Turn-On Time		25		ms	Full load, Vout=90% nom; Figures 9 & 10
Start-Up Inhibit Time	180	200	240	ms	-40°C to 125°C; Figure F
Output Voltage Overshoot		0		%	Maximum Output Capacitance, Iout=0A
ISOLATION CHARACTERISTICS					
Isolation Voltage (dielectric strength)		2000		V	See Absolute Maximum Ratings
Isolation Resistance		30		MΩ	
Isolation Capacitance (input to output)		1000		pF	See Note 4
TEMPERATURE LIMITS FOR POWER DERATING CURVES					
Semiconductor Junction Temperature			125	°C	Package rated to 150°C
Board Temperature			125	°C	UL rated max operating temp 130°C
Transformer Temperature			125	°C	
FEATURE CHARACTERISTICS					
Switching Frequency	360	400	440	kHz	
ON/OFF Control (Option P)					
Off-State Voltage	0		0.8	V	
On-State Voltage	2		13.5	V	
ON/OFF Control (Option N)					
Off-State Voltage	2		13.5	V	
On-State Voltage	0		0.8	V	
ON/OFF Control (Either Option)					Application notes; Figures A & B
Pull-Up Voltage		5	6	V	
Pull-Up Resistance		10		kΩ	
Output Voltage Trim Range	-10		10	%	Measured across Pins 8 & 4; Figure C
Output Voltage Remote Sense Range			10	%	Measured across Pins 8 & 4
Output Over-Voltage Protection		125		%	Full Load; % of nominal Vout
Over-Temperature Shutdown		125		°C	Average PCB Temperature
Over-Temperature Shutdown Restart Hysteresis		10		°C	
RELIABILITY CHARACTERISTICS					
Calculated MTBF (Telcordia)		2.5		10 ⁶ Hrs.	TR-NWT-000332; 80% load, 300LFM, 40°C Ta
Calculated MTBF (MIL-217)		1.1		10 ⁶ Hrs.	MIL-HDBK-217F; 80% load, 300LFM, 40°C Ta
Field Demonstrated MTBF				10 ⁶ Hrs.	See our website for details

Note 1: The UVLO values represented here are typical of lighter load conditions. The unit may shut down under high load conditions before the typical UVLO limits.

Note 2: For applications requiring reduced output voltage ripple and noise, consult SynQor applications support (e-mail: support@synqor.com)

Note 3: The module requires a minimum amount of capacitance (100μF) in order to ride through a No Load to Full Load transient (0.1A/μs) without shutdown.

Note 4: Higher values of isolation capacitance can be added external to the module.



Technical Specification

Input: 35-75V
Output: 15V
Current: 3.3A
Part No.: PQ60150EKx03

PQ60150EKx03 Standards & Qualification Testing

Parameter	Notes & Conditions
STANDARDS COMPLIANCE	
UL 60950-1:2003	File #E194341, Basic Insulation
CAN/CSA-C22.2 No. 60950-1:2003	
EN60950-1:2001	Certified by TUV
Needle Flame Test (IEC 695-2-2)	Test on entire assembly; board & plastic components UL94V-0 compliant
IEC 61000-4-2	ESD test, 8kV-NP, 15kV air-NP (Normal Performance)

Note: An external input fuse must always be used to meet these safety requirements. Contact SynQor for official safety certificates on new releases or download from the SynQor website.

Parameter	# Units	Test Conditions
QUALIFICATION TESTING		
Life Test	32	95% rated Vin and load, units at derating point, 1000 hours
Vibration	5	10-55Hz sweep, 0.060" total excursion, 1 min./sweep, 120 sweeps for 3 axis
Mechanical Shock	5	100g minimum, 2 drops in x and y axis, 1 drop in z axis
Temperature Cycling	10	-40°C to 100°C, unit temp. ramp 15°C/min., 500 cycles
Power/Thermal Cycling	5	Toperating=min to max, Vin=min to max, full load, 100 cycles
Design Marginality	5	Tmin-10°C to Tmax+10°C, 5°C steps, Vin=min to max, 0-105% load
Humidity	5	85°C, 85% RH, 1000 hours, continuous Vin applied except 5 min/day
Solderability	15 pins	MIL-STD-883, method 2003

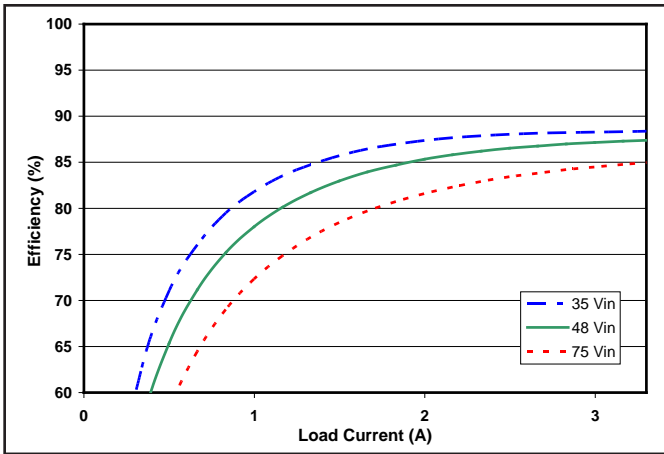

Figure 1: Efficiency at nominal output voltage vs. load current for minimum, nominal, and maximum input voltage at 25°C.

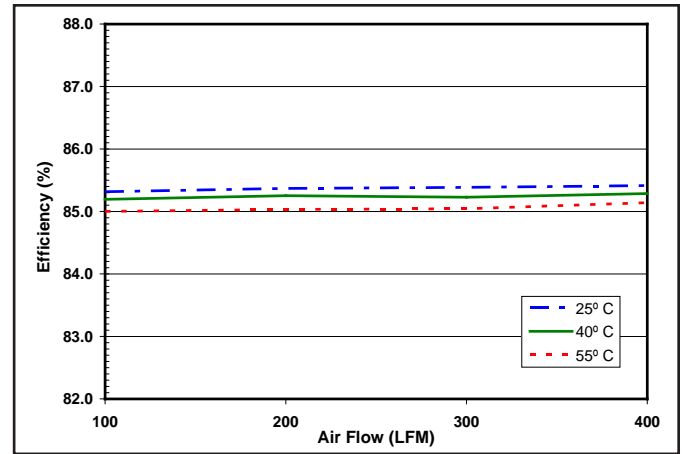

Figure 2: Efficiency at nominal output voltage and 60% rated power vs. airflow rate for ambient air temperatures of 25°C, 40°C, and 55°C (nominal input voltage).

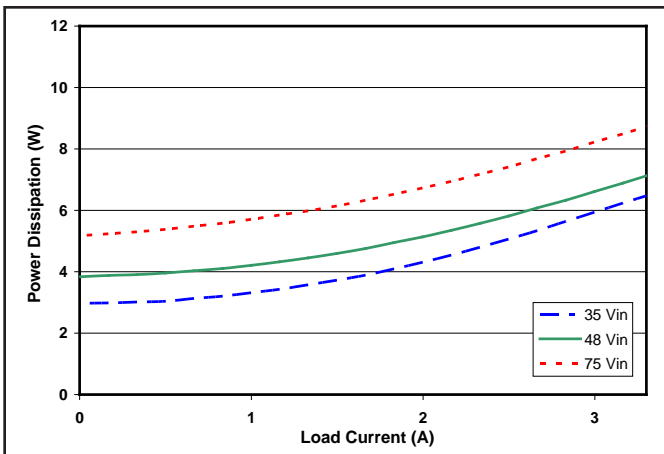

Figure 3: Power dissipation at nominal output voltage vs. load current for minimum, nominal, and maximum input voltage at 25°C.

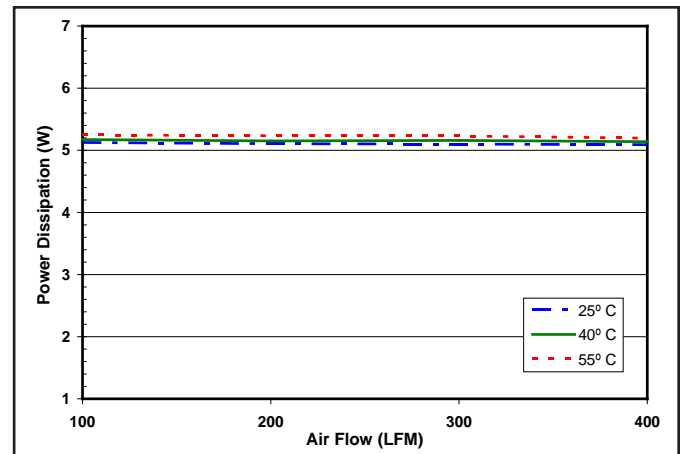

Figure 4: Power dissipation at nominal output voltage and 60% rated power vs. airflow rate for ambient air temperatures of 25°C, 40°C, and 55°C (nominal input voltage).

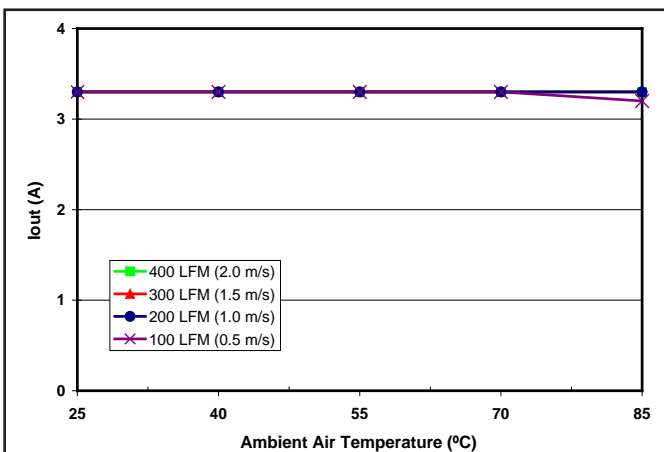

Figure 5: Maximum output power derating curves vs. ambient air temperature for airflow rates of 100LFM through 400LFM with air flowing from pin 3 to pin 1 (nominal input voltage).

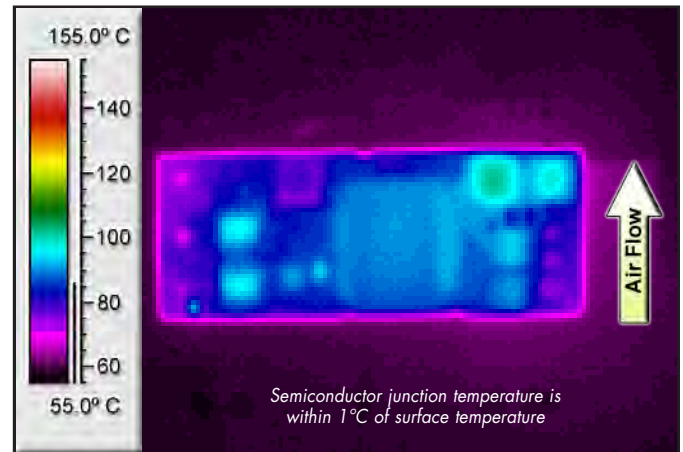

Figure 6: Thermal plot of converter at 3.3 amp load current (50W) with 55°C air flowing at the rate of 200LFM. Air is flowing from pin 3 to pin 1 (nominal input voltage).

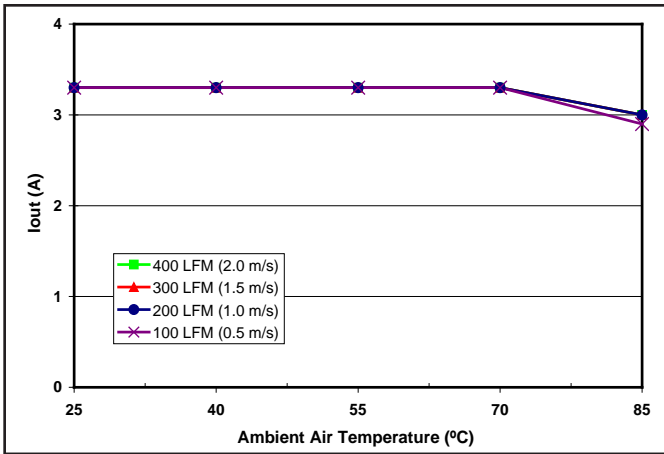

Figure 7: Maximum output power derating curves vs. ambient air temperature for airflow rates of 100LFM through 400LFM with air flowing across the converter from input to output (nominal input voltage).

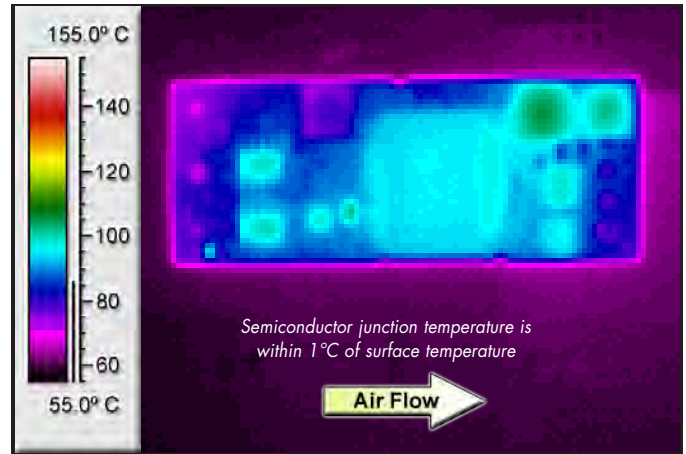

Figure 8: Thermal plot of converter 3.3A load current (50W) with 55°C air flowing at the rate of 200LFM. Air is flowing across the converter from input to output (nominal input voltage).

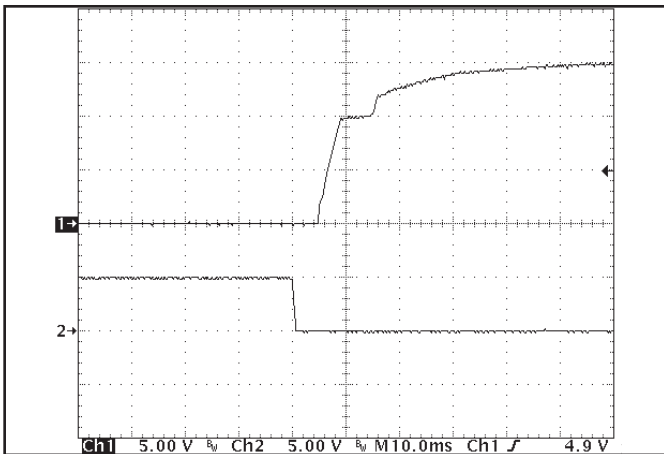

Figure 9: Turn-on transient at full load (resistive load) (10ms/div). Load cap: 15µF tantalum capacitor and 1µF ceramic cap. Input voltage pre-applied. Ch 1: V_{out} (5V/div), Ch 2: ON/OFF input (5V/div).

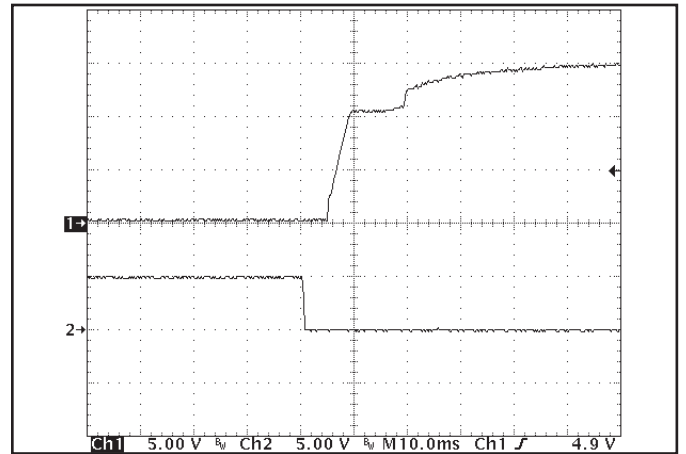

Figure 10: Turn-on transient at zero load (10ms/div). Load cap: 15µF tantalum capacitor and 1µF ceramic cap. Ch 1: V_{out} (5V/div), Ch 2: ON/OFF input (5V/div).

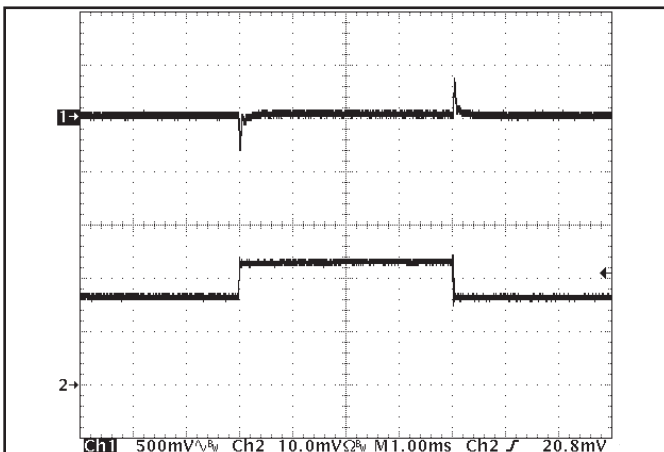

Figure 11: Output voltage response to step-change in load current (50%-75%-50% of I_{out}(max); di/dt=0.1A/µs). Load cap: 15µF tantalum cap and 1µF ceramic cap. Ch 1: V_{out} (500mV/div), Ch 2: I_{out} (1A/div).

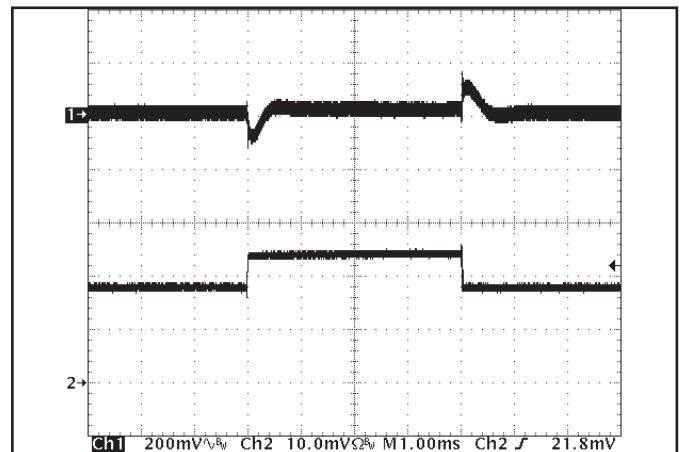

Figure 12: Output voltage response to step-change in load current (50%-75%-50% of I_{out}(max); di/dt=1A/µs). Load cap: 470µF electrolytic, 15µF tantalum and 1µF ceramic cap. Ch 1: V_{out} (200mV/div), Ch 2: I_{out} (1A/div).

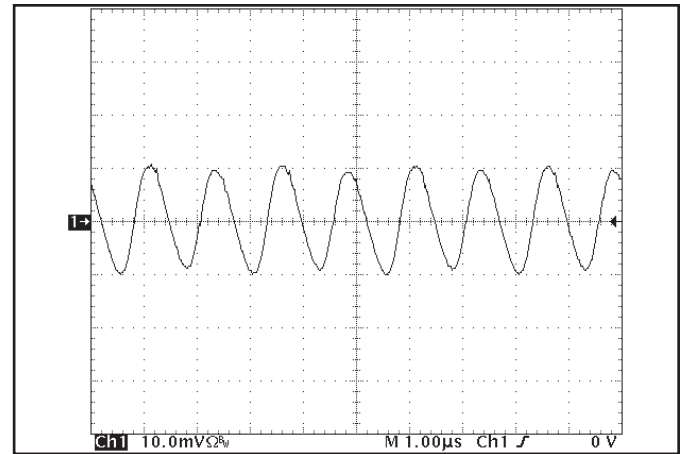
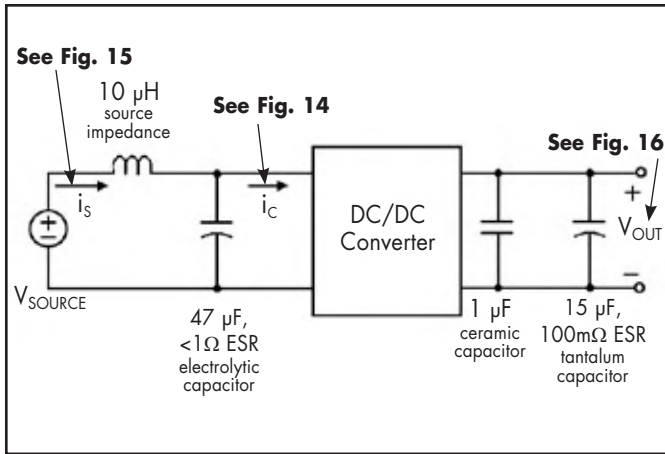

Figure 13: Test set-up diagram showing measurement points for Input Terminal Ripple Current (Figure 14), Input Reflected Ripple Current (Figure 15) and Output Voltage Ripple (Figure 16).

Figure 14: Input Terminal Ripple Current, i_c , at full rated output current and nominal input voltage with $10\ \mu\text{H}$ source impedance and $47\ \mu\text{F}$ electrolytic capacitor ($50\text{mA}/\text{div}$). See Figure 13.

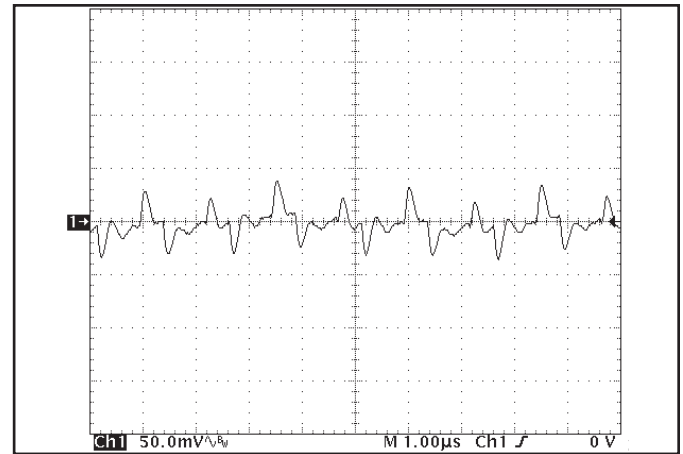
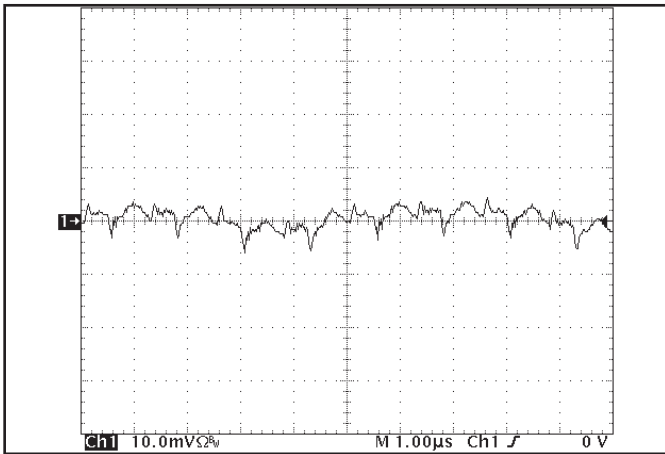

Figure 15: Input reflected ripple current, i_s , through a $10\ \mu\text{H}$ source inductor, using a $47\ \mu\text{F}$ electrolytic input capacitor ($5\text{mA}/\text{div}$). See Figure 13.

Figure 16: Output voltage ripple at nominal input voltage and rated load current ($50\text{mV}/\text{div}$). Load capacitance: $1\ \mu\text{F}$ ceramic capacitor and $15\ \mu\text{F}$ tantalum capacitor. Bandwidth: 20MHz . See Figure 13.

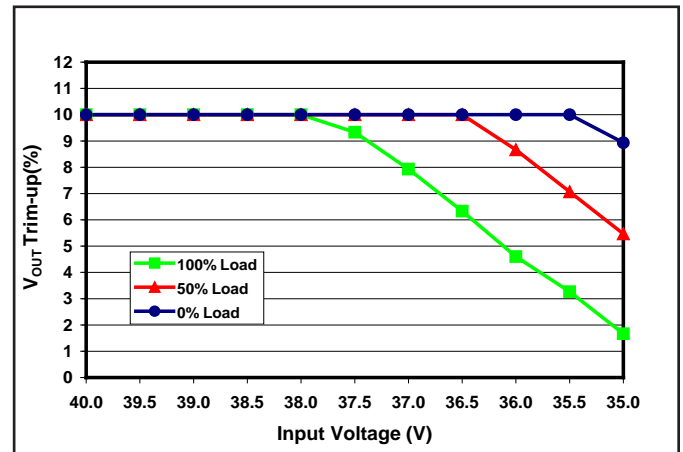
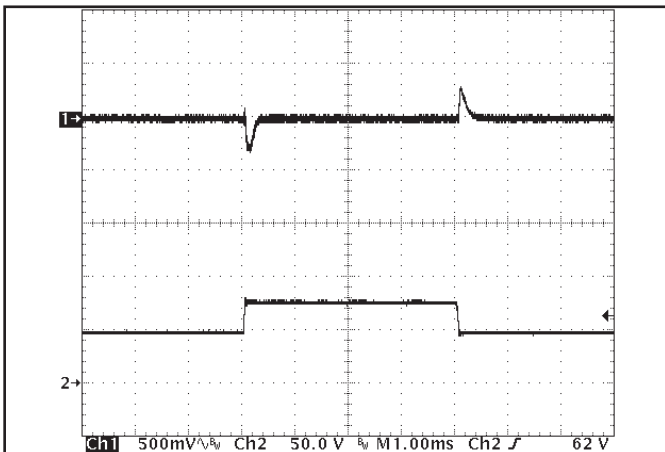

Figure 17: Output voltage response to step-change in input voltage (48V to 75V), at 3.3A load current. Load cap: $15\ \mu\text{F}$ tantalum capacitor and $1\ \mu\text{F}$ ceramic cap. Ch1: V_{out} ($500\text{mV}/\text{div}$), Ch2: V_{in} ($50\text{V}/\text{div}$)

Figure 18: Achievable trim-up percentage vs. input voltage at 0%, 50% and full load. $V_{in}=35\text{-}40\text{V}$.

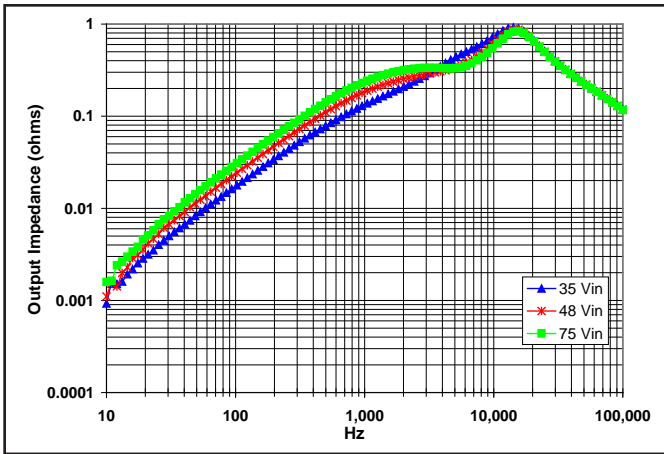

Figure 19: Magnitude of incremental output impedance ($Z_{out}=V_{out}/I_{out}$) for minimum, nominal, and maximum input voltage at full rated power.

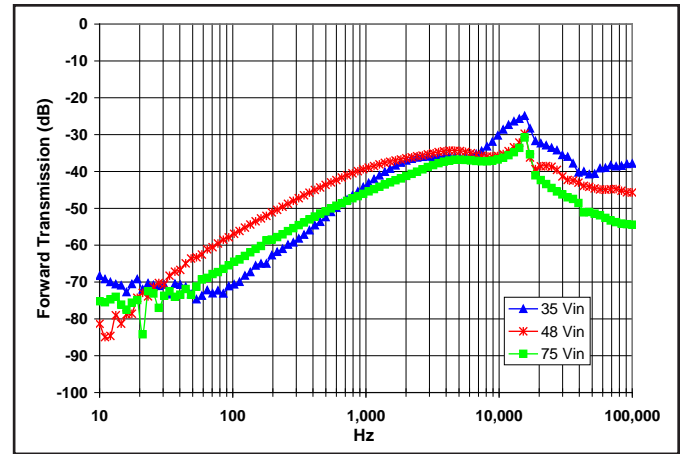

Figure 20: Magnitude of incremental forward transmission ($FT=V_{out}/V_{in}$) for minimum, nominal, and maximum input voltage at full rated power.

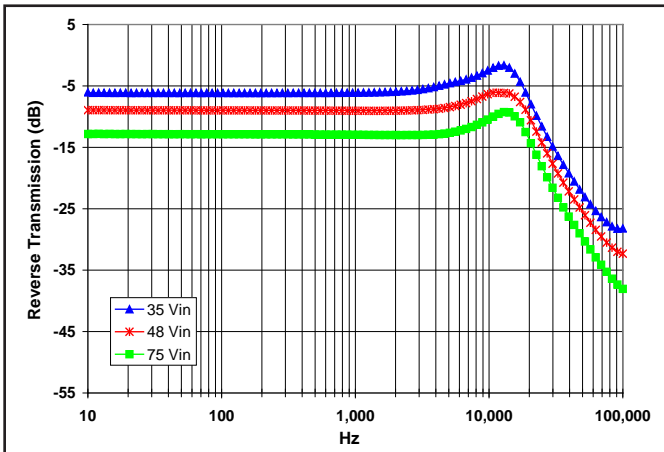

Figure 21: Magnitude of incremental reverse transmission ($RT=I_{in}/I_{out}$) for minimum, nominal, and maximum input voltage at full rated power.

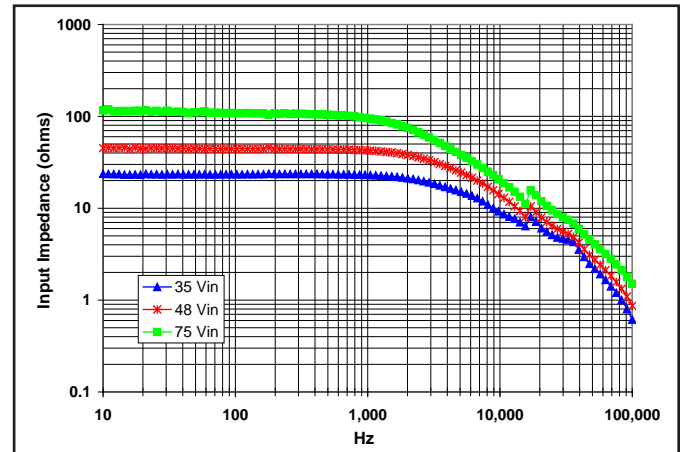

Figure 22: Magnitude of incremental input impedance ($Z_{in}=V_{in}/I_{in}$) for minimum, nominal, and maximum input voltage at full rated power.

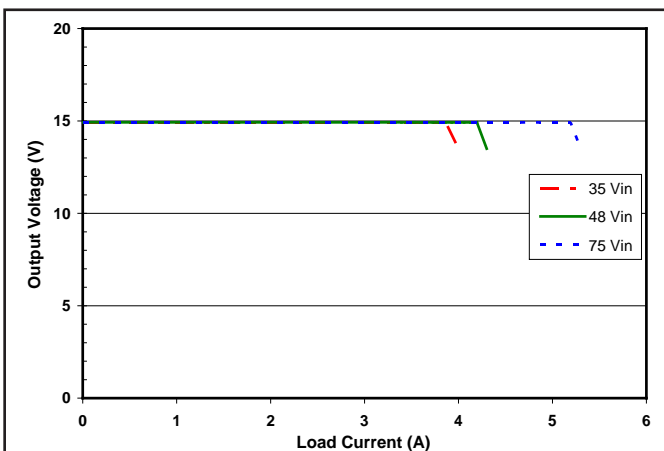

Figure 23: Output voltage vs. load current showing typical current limit curves and converter shutdown points

BASIC OPERATION AND FEATURES

The single stage power converter switches at a fixed frequency for predictable EMI performance. Rectification of the transformer's output is accomplished with synchronous rectifiers. These devices, which are MOSFETs with a very low on-state resistance, dissipate far less energy than Schottky diodes. This is the primary reason that the PowerQor converter has such high efficiency, even at very low output voltages and very high output currents.

Dissipation throughout the converter is so low that it does not require a heatsink for operation. Since a heatsink is not required, the PowerQor converter does not need a metal baseplate or potting material to help conduct the dissipated energy to the heatsink. The PowerQor converter can thus be built more simply and reliably using high yield surface mount techniques on a PCB substrate.

The PowerQor series of eighth-brick, quarter-brick and half-brick converters uses the industry standard footprint and pin-out configuration.

CONTROL FEATURES

REMOTE ON/OFF (Pin 2): The ON/OFF input, Pin 2, permits the user to control when the converter is on or off. This input is referenced to the return terminal of the input bus, Vin(-). There are two versions of the converter that differ by the sense of the logic used for the ON/OFF input.

In the positive logic version, the ON/OFF input is active high (meaning that a high turns the converter on). In the negative logic version, the ON/OFF signal is active low (meaning that a low turns the converter on). Figure A details five possible circuits for driving the ON/OFF pin. Figure B is a detailed look of the internal ON/OFF circuitry.

REMOTE SENSE(±) (Pins 7 and 5): The SENSE(±) inputs correct for voltage drops along the conductors that connect the converter's output pins to the load.

Pin 7 should be connected to Vout(+) and Pin 5 should be connected to Vout(-) at the point on the board where regulation is desired. A remote connection at the load can adjust for a voltage drop only as large as that specified in this datasheet, that is

$$\frac{[V_{out(+)} - V_{out(-)}] - [V_{sense(+)} - V_{sense(-)}]}{\text{Sense Range \%} \times V_{out}} \leq$$

Pins 7 and 5 must be connected for proper regulation of the output voltage. If these connections are not made, the converter will deliver an output voltage that is slightly higher than its specified value.

Note: the output over-voltage protection circuit senses the voltage across the output (pins 8 and 4) to determine when it should trigger, not the voltage across the converter's sense leads (pins 7 and 5). Therefore, the resistive drop on the board should be small enough so that output OVP does not trigger, even during load transients.

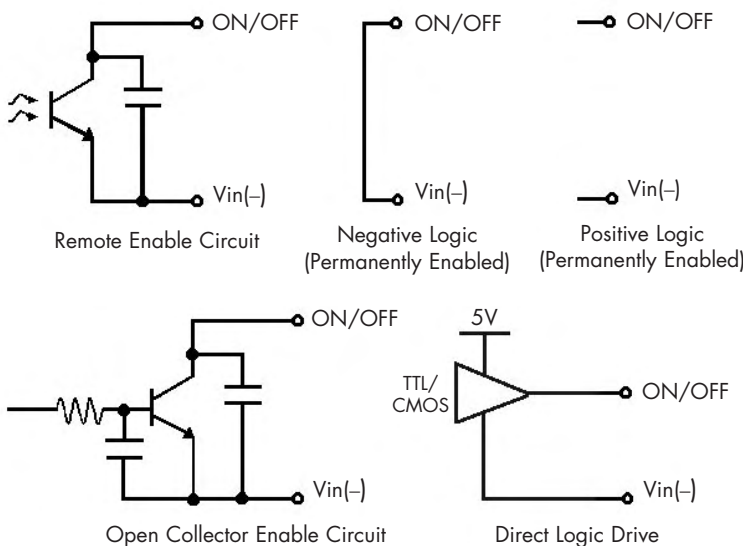

Figure A: Various circuits for driving the ON/OFF pin.

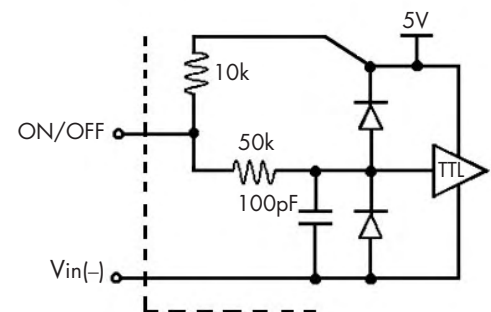

Figure B: Internal ON/OFF pin circuitry

OUTPUT VOLTAGE TRIM (Pin 6): The TRIM input permits the user to adjust the output voltage across the sense leads up or down according to the trim range specifications.

To decrease the output voltage, the user should connect a resistor between Pin 6 and Pin 5 (SENSE(-) input). For a desired decrease of the nominal output voltage, the value of the resistor should be

$$R_{\text{trim-down}} = \left(\frac{511}{\Delta\%} \right) - 10.22 \text{ (k}\Omega\text{)}$$

where

$$\Delta\% = \left| \frac{V_{\text{nominal}} - V_{\text{desired}}}{V_{\text{nominal}}} \right| \times 100\%$$

To increase the output voltage, the user should connect a resistor between Pin 6 and Pin 7 (SENSE(+) input). For a desired increase of the nominal output voltage, the value of the resistor should be

$$R_{\text{trim-up}} = \left(\frac{5.11V_{\text{OUT}}(100+\Delta\%)}{1.225\Delta\%} - \frac{511}{\Delta\%} - 10.22 \right) \text{ (k}\Omega\text{)}$$

where

$$V_{\text{OUT}} = \text{Nominal Output Voltage}$$

Figure C graphs the relationship between the trim resistor value and Rtrim-up and Rtrim-down, showing the total range the output voltage can be trimmed up or down.

Note: the TRIM feature does not affect the voltage at which the output over-voltage protection circuit is triggered. Trimming the output voltage too high may cause the over-voltage protection circuit to engage, particularly during transients.

It is not necessary for the user to add capacitance at the Trim pin. The node is internally bypassed to eliminate noise.

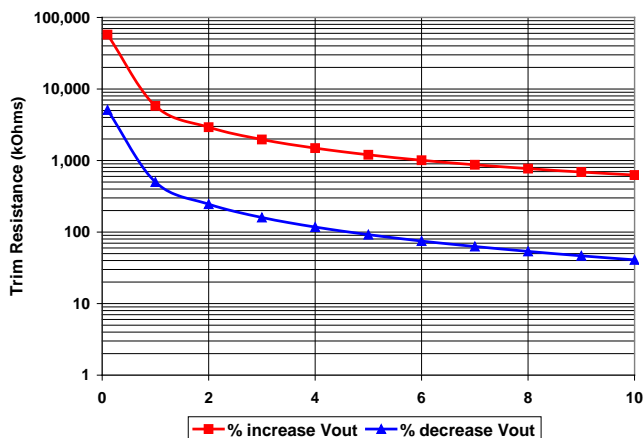

Figure C: Trim Graph for 15Vout module

Total DC Variation of Vout: For the converter to meet its full specifications, the maximum variation of the DC value of Vout, due to both trimming and remote load voltage drops, should not be greater than that specified for the output voltage trim range.

PROTECTION FEATURES

Input Under-Voltage Lockout: The converter is designed to turn off when the input voltage is too low, helping avoid an input system instability problem, described in more detail in the application note titled "Input System Instability". The lockout circuitry is a comparator with DC hysteresis. When the input voltage is rising, it must exceed the typical Turn-On Voltage Threshold value (listed on the specification page) before the converter will turn on. Once the converter is on, the input voltage must fall below the typical Turn-Off Voltage Threshold value before the converter will turn off.

Output Current Limit: Once the output current reaches the current-limit point, the converter is in the cycle-by-cycle current limit mode for a short time that the typical value is 210µs. If the over current no longer exists during this short time, the converter resumes the normal condition. If the over current still persists after this short time, the converter enters a "hiccup mode" where it repeatedly turns on and off at a 5 Hz (nominal) frequency until the over current condition is removed. The dual advantages of this design are that a short term overload will not cause a hiccup mode restart and it prevents excessive heating of the converter or the load board in extended over current condition.

Output Over-Voltage Limit: If the voltage across the output pins exceeds the Output Over-Voltage Protection threshold, the converter will immediately stop switching. This prevents damage to the load circuit due to 1) excessive series resistance in output current path from converter output pins to sense point, 2) a release of a short-circuit condition, or 3) a release of a current limit condition. Load capacitance determines exactly how high the output voltage will rise in response to these conditions. After 200 ms the converter will automatically restart.

Over-Temperature Shutdown: A temperature sensor on the converter senses the average temperature of the module. The thermal shutdown circuit is designed to turn the converter off when the temperature at the sensed location reaches the Over-Temperature Shutdown value. It will allow the converter to turn on again when the temperature of the sensed location falls by the amount of the Over-Temperature Shutdown Restart Hysteresis value.

APPLICATION CONSIDERATIONS

Input System Instability: This condition can occur because any DC/DC converter appears incrementally as a negative resistance load. A detailed application note titled "Input System Instability" is available on the SynQor website which provides an understanding of why this instability arises, and shows the preferred solution for correcting it.

Application Circuits: Figure D below provides a typical circuit diagram which details the input filtering and voltage trimming.

Input Filtering and External Capacitance: Figure E below provides a diagram showing the internal input filter components. This filter dramatically reduces input terminal ripple current, which otherwise could exceed the rating of an external input electrolytic capacitor. The recommended external input capacitance is specified in the "Input Characteristics" section. More detailed information is available in the application note titled "EMI Characteristics" on the SynQor website.

Startup Inhibit Period: The Startup Inhibit Period ensures that the converter will remain off for approximately 200ms when it is shut down for any reason. In all, there are five ways that the converter can be shut down, initiating a Startup Inhibit Period:

- Input Under-Voltage Lockout
- Output Over-Voltage Protection
- Over Temperature Shutdown
- Current Limit
- Turned off by the ON/OFF input

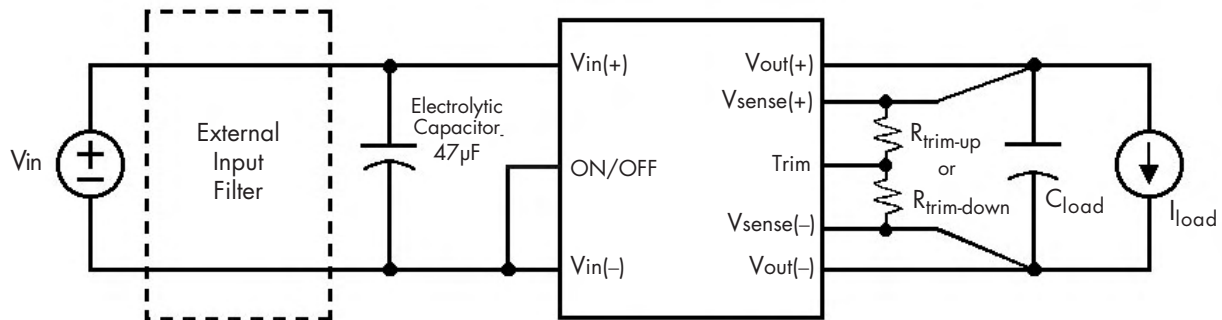

Figure D: Typical application circuit (negative logic unit, permanently enabled).

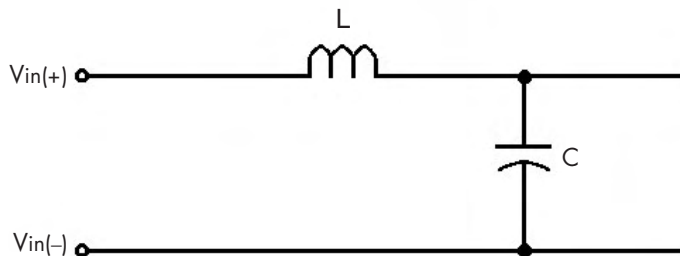

Figure E: Internal Input Filter Diagram (component values listed on the specifications page).

Figure F shows three turn-on scenarios, where a Startup Inhibit Period is initiated at t_0 , t_1 , and t_2 :

Before time t_0 , when the input voltage is below the UVL threshold, the unit is disabled by the Input Under-Voltage Lockout feature. When the input voltage rises above the UVL threshold, the Input Under-Voltage Lockout is released, and a Startup Inhibit Period is initiated. At the end of this delay, the ON/OFF pin is evaluated, and since it is active, the unit turns on.

At time t_1 , the unit is disabled by the ON/OFF pin, and it cannot be enabled again until the Startup Inhibit Period has elapsed.

When the ON/OFF pin goes high after t_2 , the Startup Inhibit Period has elapsed, and the output turns on within the typical Turn-On Time.

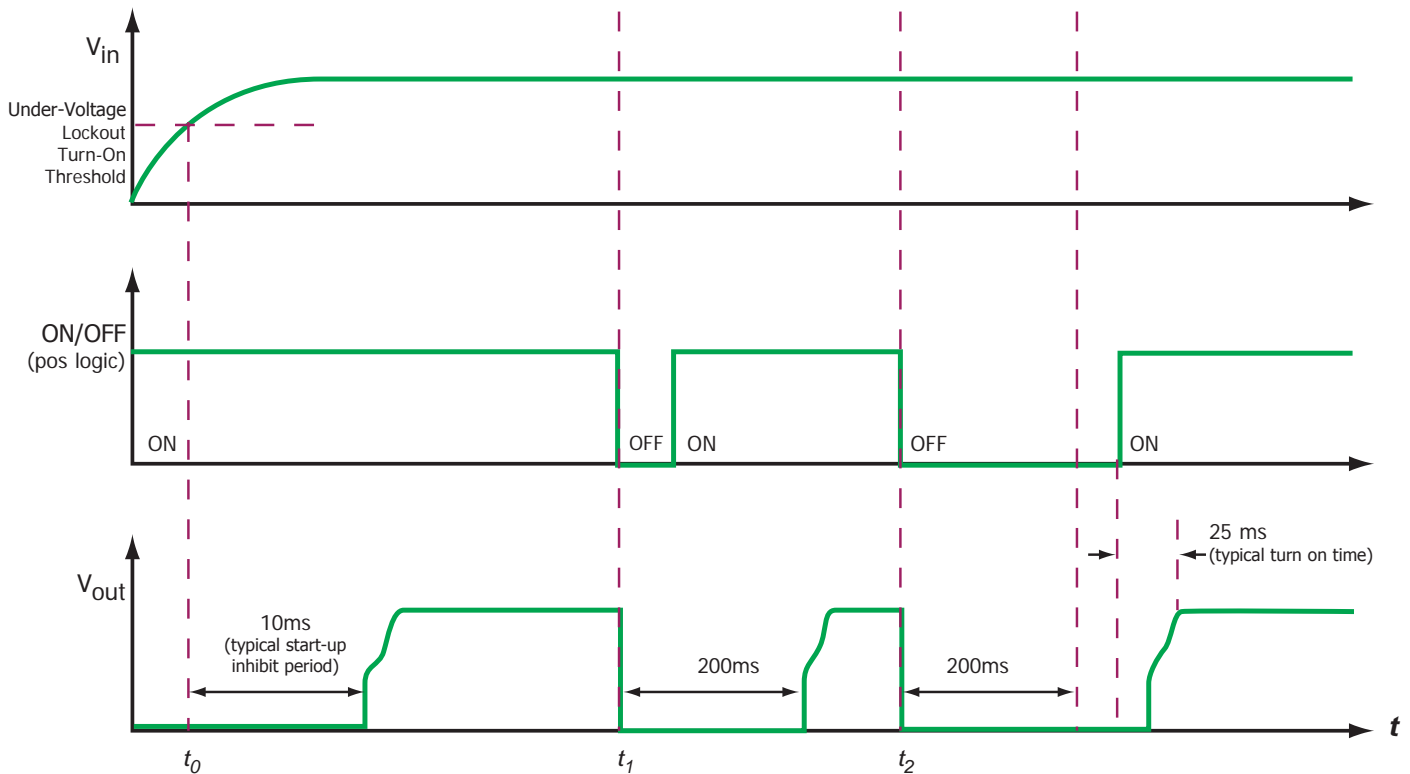

Figure F: Startup Inhibit Period (turn-on time not to scale)



Technical Specification

Input: 35-75V
Output: 15V
Current: 3.3A
Part No.: PQ60150EKx03

PART NUMBERING SYSTEM

The part numbering system for SynQor's dc-dc converters follows the format shown in the example below.

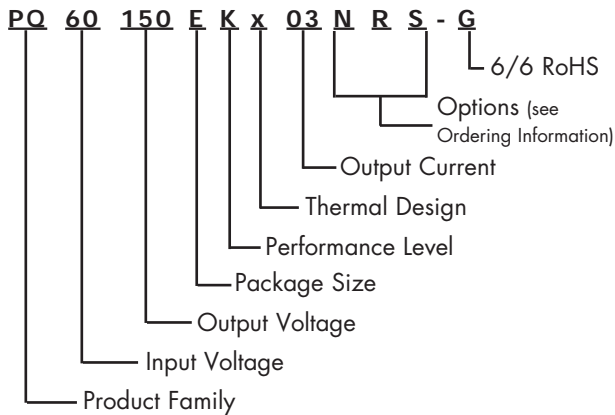

The first 12 characters comprise the base part number and the last 3 characters indicate available options. The "-G" suffix indicates 6/6 RoHS compliance.

Application Notes

A variety of application notes and technical white papers can be downloaded in pdf format from our website.

RoHS Compliance: The EU led RoHS (Restriction of Hazardous Substances) Directive bans the use of Lead, Cadmium, Hexavalent Chromium, Mercury, Polybrominated Biphenyls (PBB), and Polybrominated Diphenyl Ether (PBDE) in Electrical and Electronic Equipment. This SynQor product is 6/6 RoHS compliant. For more information please refer to SynQor's RoHS addendum available at our RoHS Compliance / Lead Free Initiative web page or e-mail us at rohs@synqor.com.

ORDERING INFORMATION

The tables below show the valid model numbers and ordering options for converters in this product family. When ordering SynQor converters, please ensure that you use the complete 15 character part number consisting of the 12 character base part number and the additional 3 characters for options. Add "-G" to the model number for 6/6 RoHS compliance.

Model Number	Input Voltage	Output Voltage	Max Output Current
PQ60150EKw03xyz	35V-75V	15V	3.3A

The following options must be included in place of the **wxyz** spaces in the model numbers listed above.

Options Description: wxyz			
Thermal Design	Enable Logic	Pin Style	Feature Set
A - Open Frame L - Low Profile C - Encased	N - Negative P - Positive	K - 0.110" N - 0.145" R - 0.180" Y - 0.250"	S - Standard

Not all combinations make valid part numbers, please contact SynQor for availability. See the [Product Summary](#) web page for more options.

PATENTS

SynQor holds the following U.S. patents, one or more of which apply to this product. Additional patent applications may be pending or filed in the future.

5,999,417	6,222,742	6,545,890	6,577,109	6,594,159
6,731,520	6,894,468	6,896,526	6,927,987	7,050,309
7,072,190	7,085,146	7,119,524	7,269,034	7,272,021
7,272,023	7,558,083	7,564,702		

Contact SynQor for further information:

Phone: 978-849-0600
Toll Free: 888-567-9596
Fax: 978-849-0602
E-mail: power@synqor.com
Web: www.synqor.com
Address: 155 Swanson Road
 Boxborough, MA 01719
 USA

Warranty

SynQor offers a three (3) year limited warranty. Complete warranty information is listed on our website or is available upon request from SynQor.

Information furnished by SynQor is believed to be accurate and reliable. However, no responsibility is assumed by SynQor for its use, nor for any infringements of patents or other rights of third parties which may result from its use. No license is granted by implication or otherwise under any patent or patent rights of SynQor.