

SPECIFICATIONS

Board to Board Connector

Mechanical

CONNECTOR MATING FORCE: 170 gf/pin MAX.
CONNECTOR UNMATING FORCE: 10 gf/pin MIN.
Durability: 20 cycles

Electrical

Operating Voltage: 30V AC RMS max.
Current Rating: 0.3A max.
Contact Resistance: 100mΩ max.
Dielectric Withstanding Voltage: 100V AC/1 min.
Insulation Resistance: 50MΩ

Physical

Housing: Hi-Temp. Thermoplastic, UL 94V-0 rated in Black Color
Contact: BeCu
Plating: See "ORDERING INFORMATION"
Operating Temperature: -35°C to +85°C

QG23 Series
Receptacle, S/T, SMT Type
0.4mm [.0157"] Pitch
0.9mm [.0354"] Mated
Height

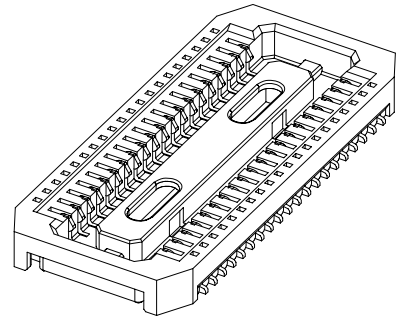

DRAWING

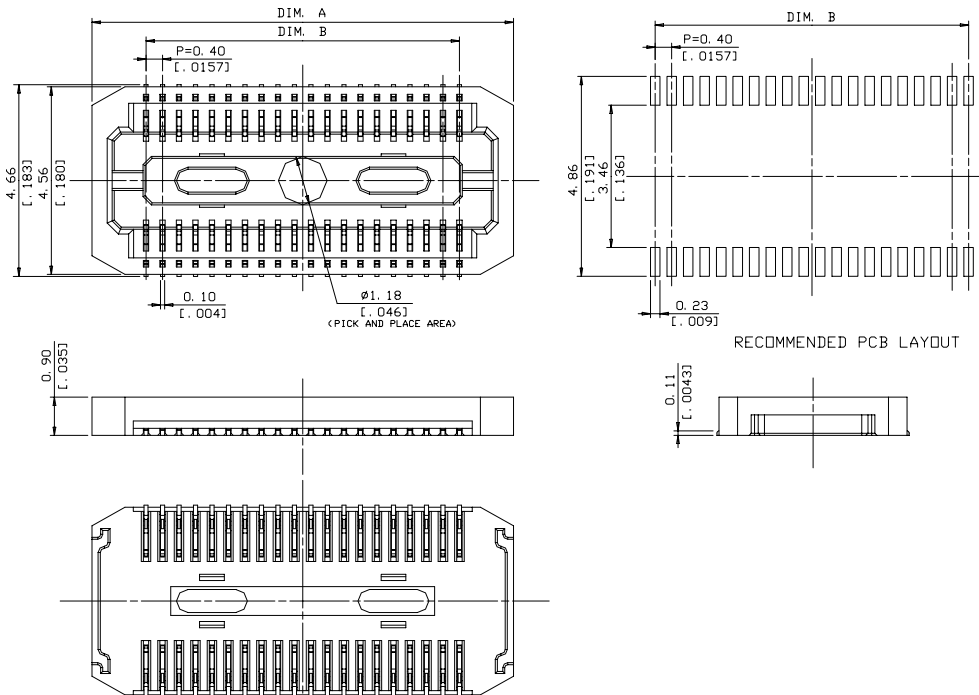

ORDERING INFORMATION

PRODUCT NO.: Q G 2 3 * * 4 3 1 Y - H04 - T R

- BTB Conn. _____
- Conn. Type _____
2=Female
- Body & Terminal Type _____
3=S/T,SMT
- Number of Contact _____
40=40 Pin
50=50 Pin
- Contact Pitch _____
4=0.4MM
- Package _____
TR=Tape & Reel
- Extension Code _____
Running Number
- Contact Area Plating _____
Y=5-10u" Gold Plating
- Variation Code _____
1=Without Anchor and Without Boss and Without shielding
- Mating Height _____
3=0.9MM

PART NO.	NO. OF CONTACTS	A	B
QG2340431Y-H04-TR	40	10.22 [.402]	7.60 [.300]
QG2350431Y-H04-TR	50	12.22 [.481]	9.60 [.378]