

### Features...

### Preliminary Information

- High-performance CMOS EEPROM-based programmable logic devices (PLDs) built on second-generation Multiple Array MatriX (MAX<sup>®</sup>) architecture (see [Table 1](#))
- 3.3-V in-system programmability (ISP) through the built-in IEEE Std. 1149.1 Joint Test Action Group (JTAG) interface with advanced pin-locking capability
- Built-in boundary-scan test (BST) circuitry compliant with IEEE Std. 1149.1-1990
- Enhanced ISP features
  - Enhanced ISP algorithm for faster programming (excluding EPM7128A and EPM7256A devices)
  - ISP\_Done bit to ensure complete programming (excluding EPM7128A and EPM7256A devices)
  - Pull-up resistor on I/O pins during in-system programming
- Pin-compatible with the popular 5.0-V MAX 7000S devices
- High-density PLDs ranging from 600 to 10,000 usable gates
- 4.5-ns pin-to-pin logic delays with counter frequencies of up to 192.3 MHz



For information on in-system programmable 5.0-V MAX 7000 or 2.5-V MAX 7000B devices, see the [MAX 7000 Programmable Logic Device Family Data Sheet](#) or the [MAX 7000B Programmable Logic Device Family Advance Information Brief](#).

**Table 1. MAX 7000A Device Features**

Feature	EPM7032AE	EPM7064AE	EPM7128AE EPM7128A	EPM7256AE EPM7256A	EPM7512AE
Usable gates	600	1,250	2,500	5,000	10,000
Macrocells	32	64	128	256	512
Logic array blocks	2	4	8	16	32
Maximum user I/O pins	36	68	100	164	212
t <sub>PD</sub> (ns)	4.5	4.5	5.0	5.5	7.5
t <sub>SU</sub> (ns)	3.0	3.0	3.2	3.5	4.9
t <sub>FSU</sub> (ns)	2.5	2.5	2.5	2.5	3.0
t <sub>CO1</sub> (ns)	2.8	2.8	3.0	3.2	4.5
f <sub>CNT</sub> (MHz)	192.3	192.3	181.8	163.9	119.0

## ...and More Features

- MultiVolt™ I/O interface enabling device core to run at 3.3 V, while I/O pins are compatible with 5.0-V, 3.3-V, and 2.5-V logic levels
- Pin counts ranging from 44 to 256 in a variety of thin quad flat pack (TQFP), plastic quad flat pack (PQFP), ball-grid array (BGA), space-saving FineLine BGA™, and plastic J-lead chip carrier (PLCC) packages
- Supports hot-socketing in MAX 7000AE devices
- Programmable interconnect array (PIA) continuous routing structure for fast, predictable performance
- Peripheral component interconnect (PCI) compatible
- Bus friendly architecture including programmable slew-rate control
- Open-drain output option
- Programmable macrocell registers with individual clear, preset, clock, and clock enable controls
- Programmable power-up states for macrocell registers in MAX 7000AE devices
- Programmable power-saving mode for 50% or greater power reduction in each macrocell
- Configurable expander product-term distribution, allowing up to 32 product terms per macrocell
- Programmable security bit for protection of proprietary designs
- 6 to 10 pin- or logic-driven output enable signals
- Two global clock signals with optional inversion
- Enhanced interconnect resources for improved routability
- Fast input setup times provided by a dedicated path from I/O pin to macrocell registers
- Programmable output slew-rate control
- Programmable ground pins
- Software design support and automatic place-and-route provided by Altera's MAX+PLUS® II development system for Windows-based PCs and Sun SPARCstation, HP 9000 Series 700/800, and IBM RISC System/6000 workstations, and the Quartus™ development system for Windows-based PCs and Sun SPARCstation and HP 9000 Series 700 workstations
- Additional design entry and simulation support provided by EDIF 2.0.0 and 3.0.0 netlist files, library of parameterized modules (LPM), Verilog HDL, VHDL, and other interfaces to popular EDA tools from manufacturers such as Cadence, Exemplar Logic, Mentor Graphics, OrCAD, Synopsys, Synplicity, and VeriBest
- Programming support with Altera's Master Programming Unit (MPU), BitBlaster™ serial download cable, ByteBlaster™ parallel port download cable, ByteBlasterMV™ parallel port download cable, and MasterBlaster™ serial/universal serial bus (USB) communications cable, as well as programming hardware from third-party manufacturers and any Jam™ File (.jam), Jam Byte-Code File (.jbc), or Serial Vector Format File- (.svf) capable in-circuit tester (the ByteBlaster cable is obsolete and is replaced by the ByteBlasterMV cable)

## General Description

MAX 7000A (including MAX 7000AE) devices are high-density, high-performance devices based on Altera's second-generation MAX architecture. Fabricated with advanced CMOS technology, the EEPROM-based MAX 7000A devices operate with a 3.3-V supply voltage and provide 600 to 10,000 usable gates, ISP, pin-to-pin delays as fast as 4.5 ns, and counter speeds of up to 192.3 MHz. MAX 7000A devices in the -4, -5, -6, -7, and -10 speed grades are compatible with the timing requirements of the PCI Special Interest Group (PCI SIG) *PCI Local Bus Specification, Revision 2.2*. See [Table 2](#).

Device	Speed Grade					
	-4	-5	-6	-7	-10	-12
EPM7032AE	✓			✓	✓	
EPM7064AE	✓			✓	✓	
EPM7128A			✓	✓	✓	✓
EPM7128AE		✓		✓	✓	
EPM7256A				✓	✓	✓
EPM7256AE		✓		✓	✓	
EPM7512AE				✓	✓	✓

**Notes:**

- (1) Contact Altera Applications for up-to-date information on available device speed grades.
- (2) Timing parameters for these speed grades are preliminary.

The MAX 7000A architecture supports 100% TTL emulation and high-density integration of SSI, MSI, and LSI logic functions. It easily integrates multiple devices ranging from PALs, GALs, and 22V10s to MACH, and pLSI devices. MAX 7000A devices are available in a wide range of packages, including PLCC, BGA, FineLine BGA, PQFP, and TQFP packages. See [Table 3](#).

**Table 3. MAX 7000A Maximum User I/O Pins** *Notes (1), (2)*

Device	44-Pin PLCC	44-Pin TQFP	84-Pin PLCC	100-Pin TQFP	100-Pin FineLine BGA (3)	144-Pin TQFP	208-Pin PQFP	256-Pin BGA	256-Pin FineLine BGA (3)
EPM7032AE	36	36							
EPM7064AE	36	36		68	68				68
EPM7128A			68	84	84	100			100
EPM7128AE			68	84	84	100			100
EPM7256A				84		120	164		164
EPM7256AE				84	84	120	164		164
EPM7512AE						120	176	212	212

**Notes:**

- (1) Contact Altera for up-to-date information on available device package options.
- (2) When the IEEE Std. 1149.1 (JTAG) interface is used for in-system programming or boundary-scan testing, four I/O pins become JTAG pins.
- (3) All FineLine BGA packages are footprint-compatible via the SameFrame feature. Therefore, designers can design a board to support a variety of devices, providing a flexible migration path across densities and pin counts. Device migration is fully supported by Altera development tools. See [“SameFrame Pin-Outs”](#) on page 14 for more details.

MAX 7000A devices use CMOS EEPROM cells to implement logic functions. The user-configurable MAX 7000A architecture accommodates a variety of independent combinatorial and sequential logic functions. The devices can be reprogrammed for quick and efficient iterations during design development and debug cycles, and can be programmed and erased up to 100 times.

MAX 7000A devices contain from 32 to 512 macrocells that are combined into groups of 16 macrocells, called logic array blocks (LABs). Each macrocell has a programmable-AND/fixed-OR array and a configurable register with independently programmable clock, clock enable, clear, and preset functions. To build complex logic functions, each macrocell can be supplemented with both shareable expander product terms and high-speed parallel expander product terms to provide up to 32 product terms per macrocell.

MAX 7000A devices provide programmable speed/power optimization. Speed-critical portions of a design can run at high speed/full power, while the remaining portions run at reduced speed/low power. This speed/power optimization feature enables the designer to configure one or more macrocells to operate at 50% or lower power while adding only a nominal timing delay. MAX 7000A devices also provide an option that reduces the slew rate of the output buffers, minimizing noise transients when non-speed-critical signals are switching. The output drivers of all MAX 7000A devices can be set for 2.5 V or 3.3 V and all input pins are 2.5-V, 3.3-V, and 5.0-V tolerant, allowing MAX 7000A devices to be used in mixed-voltage systems.

MAX 7000A devices are supported by the Quartus and MAX+PLUS II development systems, which are integrated packages that offer schematic, text—including VHDL, Verilog HDL, and the Altera Hardware Description Language (AHDL)—and waveform design entry, compilation and logic synthesis, simulation and timing analysis, and device programming. The Quartus and MAX+PLUS II software provides EDIF 2.0.0 and 3.0.0, LPM, VHDL, Verilog HDL, and other interfaces for additional design entry and simulation support from other industry-standard PC- and UNIX-workstation-based EDA tools. The MAX+PLUS II software runs on Windows-based PCs, as well as Sun SPARCstation, HP 9000 Series 700/800, and IBM RISC System/6000 workstations. The Quartus software runs on Windows-based PCs, as well as Sun SPARCstation and HP 9000 Series 700 workstations.



For more information on development tools, see the [MAX+PLUS II Programmable Logic Development System & Software Data Sheet](#) and the [Quartus Programmable Logic Development System Data Sheet](#).

## Functional Description

The MAX 7000A architecture includes the following elements:

- Logic array blocks (LABs)
- Macrocells
- Expander product terms (shareable and parallel)
- Programmable interconnect array
- I/O control blocks

The MAX 7000A architecture includes four dedicated inputs that can be used as general-purpose inputs or as high-speed, global control signals (clock, clear, and two output enable signals) for each macrocell and I/O pin. [Figure 1](#) shows the architecture of MAX 7000A devices.

Figure 1. MAX 7000A Device Block Diagram

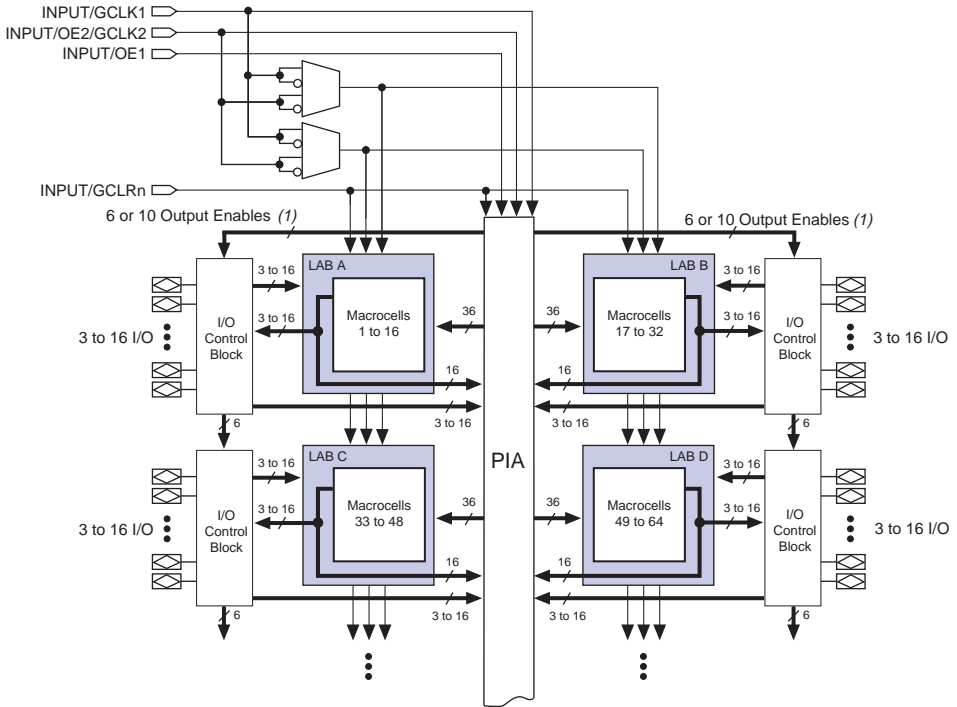

**Note:**

- (1) EPM7032AE, EPM7064AE, EPM7128A, EPM7128AE, EPM7256A, and EPM7256AE devices have six output enables. EPM7512AE devices have 10 output enables.

### Logic Array Blocks

The MAX 7000A device architecture is based on the linking of high-performance LABs. LABs consist of 16-macrocell arrays, as shown in Figure 1. Multiple LABs are linked together via the PIA, a global bus that is fed by all dedicated input pins, I/O pins, and macrocells.

Each LAB is fed by the following signals:

- 36 signals from the PIA that are used for general logic inputs
- Global controls that are used for secondary register functions
- Direct input paths from I/O pins to the registers that are used for fast setup times

### Macrocells

The MAX 7000A macrocell can be individually configured for either sequential or combinatorial logic operation. The macrocell consists of three functional blocks: the logic array, the product-term select matrix, and the programmable register. Figure 2 shows the MAX 7000A macrocell.

Figure 2. MAX 7000A Macrocell

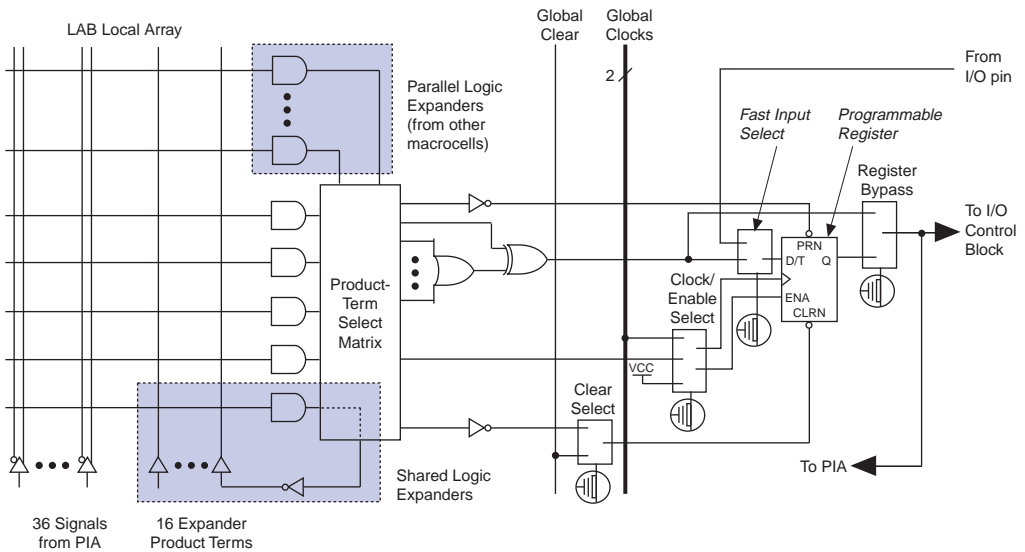

Combinatorial logic is implemented in the logic array, which provides five product terms per macrocell. The product-term select matrix allocates these product terms for use as either primary logic inputs (to the OR and XOR gates) to implement combinatorial functions, or as secondary inputs to the macrocell's register preset, clock, and clock enable control functions.

Two kinds of expander product terms ("expanders") are available to supplement macrocell logic resources:

- Shareable expanders, which are inverted product terms that are fed back into the logic array
- Parallel expanders, which are product terms borrowed from adjacent macrocells

The MAX+PLUS II development system automatically optimizes product-term allocation according to the logic requirements of the design.

For registered functions, each macrocell flipflop can be individually programmed to implement D, T, JK, or SR operation with programmable clock control. The flipflop can be bypassed for combinatorial operation. During design entry, the designer specifies the desired flipflop type; the MAX+PLUS II software then selects the most efficient flipflop operation for each registered function to optimize resource utilization.

Each programmable register can be clocked in three different modes:

- Global clock signal. This mode achieves the fastest clock-to-output performance.
- Global clock signal enabled by an active-high clock enable. A clock enable is generated by a product term. This mode provides an enable on each flipflop while still achieving the fast clock-to-output performance of the global clock.
- Array clock implemented with a product term. In this mode, the flipflop can be clocked by signals from buried macrocells or I/O pins.

Two global clock signals are available in MAX 7000A devices. As shown in [Figure 1](#), these global clock signals can be the true or the complement of either of the global clock pins, GCLK1 or GCLK2.

Each register also supports asynchronous preset and clear functions. As shown in [Figure 2](#), the product-term select matrix allocates product terms to control these operations. Although the product-term-driven preset and clear from the register are active high, active-low control can be obtained by inverting the signal within the logic array. In addition, each register clear function can be individually driven by the active-low dedicated global clear pin (GCLRn). Upon power-up, each register in a MAX 7000AE device may be set to either a high or low state. This power-up state is specified at design entry.

All MAX 7000A I/O pins have a fast input path to a macrocell register. This dedicated path allows a signal to bypass the PIA and combinatorial logic and be clocked to an input D flipflop with an extremely fast (as low as 2.5 ns) input setup time.



### Expander Product Terms

Although most logic functions can be implemented with the five product terms available in each macrocell, more complex logic functions require additional product terms. Another macrocell can be used to supply the required logic resources. However, the MAX 7000A architecture also offers both shareable and parallel expander product terms (“expanders”) that provide additional product terms directly to any macrocell in the same LAB. These expanders help ensure that logic is synthesized with the fewest possible logic resources to obtain the fastest possible speed.

#### Shareable Expanders

Each LAB has 16 shareable expanders that can be viewed as a pool of uncommitted single product terms (one from each macrocell) with inverted outputs that feed back into the logic array. Each shareable expander can be used and shared by any or all macrocells in the LAB to build complex logic functions. A small delay ( $t_{SEXP}$ ) is incurred when shareable expanders are used. Figure 3 shows how shareable expanders can feed multiple macrocells.

**Figure 3. MAX 7000A Shareable Expanders**

*Shareable expanders can be shared by any or all macrocells in an LAB.*

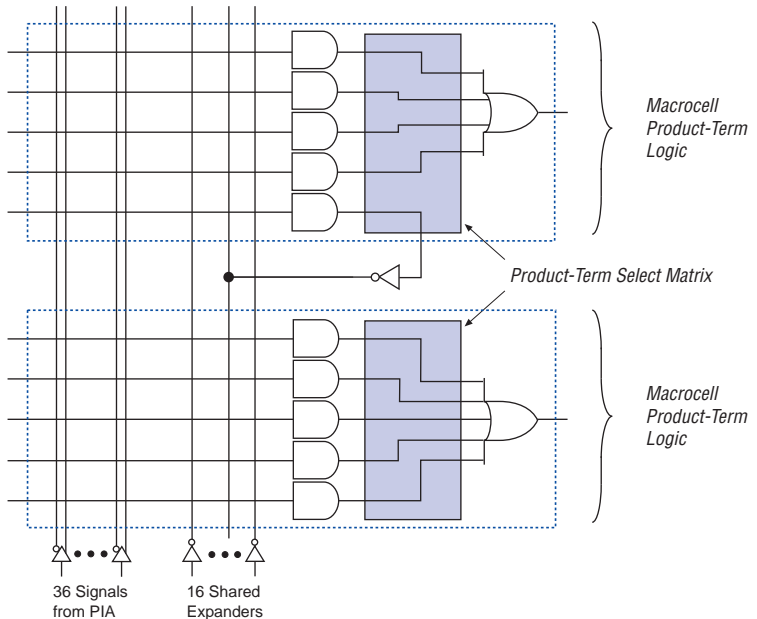

### *Parallel Expanders*

Parallel expanders are unused product terms that can be allocated to a neighboring macrocell to implement fast, complex logic functions. Parallel expanders allow up to 20 product terms to directly feed the macrocell OR logic, with five product terms provided by the macrocell and 15 parallel expanders provided by neighboring macrocells in the LAB.

The MAX+PLUS II Compiler can allocate up to three sets of up to five parallel expanders automatically to the macrocells that require additional product terms. Each set of five parallel expanders incurs a small, incremental timing delay ( $t_{PEXP}$ ). For example, if a macrocell requires 14 product terms, the Compiler uses the five dedicated product terms within the macrocell and allocates two sets of parallel expanders; the first set includes five product terms and the second set includes four product terms, increasing the total delay by  $2 \times t_{PEXP}$ .

Two groups of eight macrocells within each LAB (e.g., macrocells 1 through 8 and 9 through 16) form two chains to lend or borrow parallel expanders. A macrocell borrows parallel expanders from lower-numbered macrocells. For example, macrocell 8 can borrow parallel expanders from macrocell 7, from macrocells 7 and 6, or from macrocells 7, 6, and 5. Within each group of eight, the lowest-numbered macrocell can only lend parallel expanders and the highest-numbered macrocell can only borrow them. [Figure 4](#) shows how parallel expanders can be borrowed from a neighboring macrocell.

**Figure 4. MAX 7000A Parallel Expanders**

*Unused product terms in a macrocell can be allocated to a neighboring macrocell.*

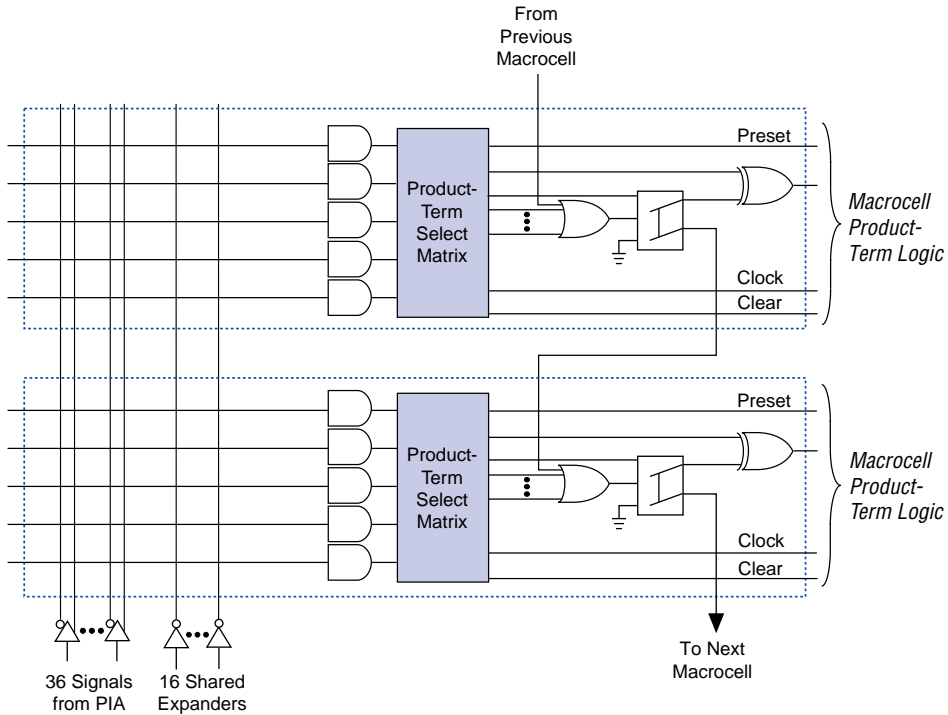

### Programmable Interconnect Array

Logic is routed between LABs on the PIA. This global bus is a programmable path that connects any signal source to any destination on the device. All MAX 7000A dedicated inputs, I/O pins, and macrocell outputs feed the PIA, which makes the signals available throughout the entire device. Only the signals required by each LAB are actually routed from the PIA into the LAB. Figure 5 shows how the PIA signals are routed into the LAB. An EEPROM cell controls one input to a 2-input AND gate, which selects a PIA signal to drive into the LAB.

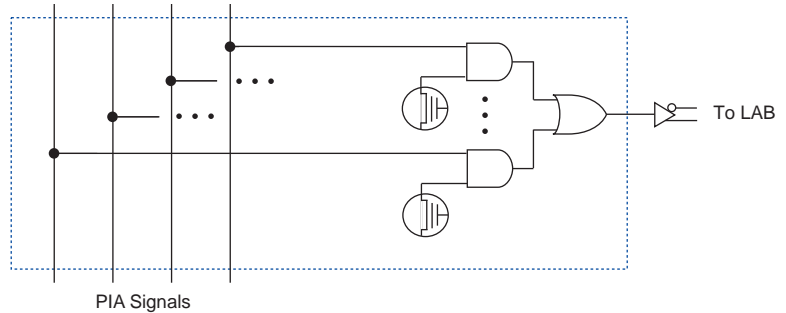
**Figure 5. MAX 7000A PIA Routing**

While the routing delays of channel-based routing schemes in masked or field-programmable gate arrays (FPGAs) are cumulative, variable, and path-dependent, the MAX 7000A PIA has a predictable delay. The PIA makes a design's timing performance easy to predict.

### I/O Control Blocks

The I/O control block allows each I/O pin to be individually configured for input, output, or bidirectional operation. All I/O pins have a tri-state buffer that is individually controlled by one of the global output enable signals or directly connected to ground or  $V_{CC}$ . Figure 6 shows the I/O control block for MAX 7000A devices. The I/O control block has 6 or 10 global output enable signals that are driven by the true or complement of two output enable signals, a subset of the I/O pins, or a subset of the I/O macrocells.

Figure 6. I/O Control Block of MAX 7000A Devices

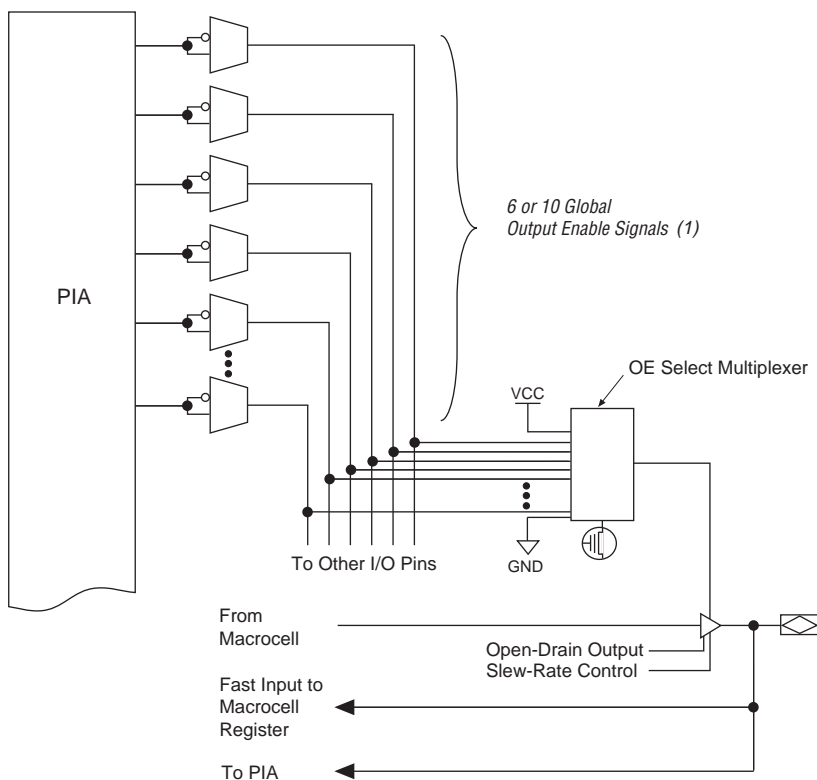
**Note:**

- (1) EPM7032AE, EPM7064AE, EPM7128A, EPM7128AE, EPM7256A, and EPM7256AE devices have six output enable signals. EPM7512AE devices have 10 output enable signals.

When the tri-state buffer control is connected to ground, the output is tri-stated (high impedance) and the I/O pin can be used as a dedicated input. When the tri-state buffer control is connected to  $V_{CC}$ , the output is enabled.

The MAX 7000A architecture provides dual I/O feedback, in which macrocell and pin feedbacks are independent. When an I/O pin is configured as an input, the associated macrocell can be used for buried logic.

## SameFrame Pin-Outs

MAX 7000A devices support the SameFrame pin-out feature for FineLine BGA packages. The SameFrame pin-out feature is the arrangement of balls on FineLine BGA packages such that the lower-ball-count packages form a subset of the higher-ball-count packages. SameFrame pin-outs provide the flexibility to migrate not only from device to device within the same package, but also from one package to another. A given printed circuit board (PCB) layout can support multiple device density/package combinations. For example, a single board layout can support a range of devices from an EPM7128A device in a 100-pin FineLine BGA package to an EPM7512AE device in a 256-pin FineLine BGA package.

The Quartus and MAX+PLUS II software provides support to design PCBs with SameFrame pin-out devices. Devices can be defined for present and future use. The Quartus and MAX+PLUS II software generates pin-outs describing how to lay out a board to take advantage of this migration (see [Figure 7](#)).

**Figure 7. SameFrame Pin-Out Example**

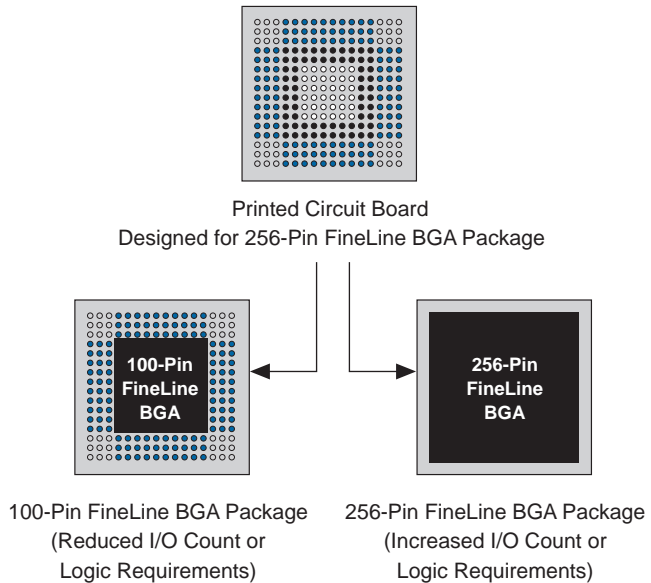

## In-System Programmability (ISP)

MAX 7000A devices can be programmed in-system via an industry-standard 4-pin IEEE Std. 1149.1-1990 (JTAG) interface. ISP offers quick, efficient iterations during design development and debugging cycles. The MAX 7000A architecture internally generates the high programming voltages required to program EEPROM cells, allowing in-system programming with only a single 3.3-V power supply. During in-system programming, the I/O pins are tri-stated and weakly pulled-up to eliminate board conflicts. The pull-up value is nominally 50 k $\Omega$ .

MAX 7000AE devices have an enhanced ISP algorithm for faster programming. These devices also offer an ISP\_Done bit that provides safe operation when in-system programming is interrupted. This ISP\_Done bit, which is the last bit programmed, prevents all I/O pins from driving until the bit is programmed. This feature is available in EPM7032AE, EPM7064AE, EPM7128AE, EPM7256AE, and EPM7512AE devices only.

ISP simplifies the manufacturing flow by allowing devices to be mounted on a printed circuit board (PCB) with standard pick-and-place equipment before they are programmed. MAX 7000A devices can be programmed by downloading the information via in-circuit testers, embedded processors, the Altera BitBlaster serial download cable, ByteBlaster parallel port download cable, ByteBlasterMV parallel port download cable, and MasterBlaster serial/USB communications cable. Programming the devices after they are placed on the board eliminates lead damage on high-pin-count packages (e.g., QFP packages) due to device handling. MAX 7000A devices can be reprogrammed after a system has already shipped to the field. For example, product upgrades can be performed in the field via software or modem.

In-system programming can be accomplished with either an adaptive or constant algorithm. An adaptive algorithm reads information from the unit and adapts subsequent programming steps to achieve the fastest possible programming time for that unit. A constant algorithm uses a pre-defined (non-adaptive) programming sequence that does not take advantage of adaptive algorithm programming time improvements. Some automatic test equipment (ATE) cannot program using an adaptive algorithm. Therefore, a constant algorithm must be used. MAX 7000AE devices can be programmed with either an adaptive or constant (non-adaptive) algorithm. EPM7218A and EPM7256A device can only be programmed with an adaptive algorithm; users programming these two devices on platforms that cannot use an adaptive algorithm should use EPM7128AE and EPM7256AE devices.

The Jam programming and test language can be used to program MAX 7000A devices with in-circuit testers, PCs, or embedded processors.



For more information on using the Jam language, see [Application Note 88 \(Using the Jam Language for ISP & ICR via an Embedded Processor\)](#).

## Programming with External Hardware

MAX 7000A devices can be programmed on Windows-based PCs with an Altera Logic Programmer card, the MPU, and the appropriate device adapter. The MPU performs continuity checking to ensure adequate electrical contact between the adapter and the device. For more information, see the *Altera Programming Hardware Data Sheet*.

The MAX+PLUS II software can use text- or waveform-format test vectors created with the MAX+PLUS II Text Editor or Waveform Editor to test the programmed device. For added design verification, designers can perform functional testing to compare the functional device behavior with the results of simulation.

Data I/O, BP Microsystems, and other programming hardware manufacturers provide programming support for Altera devices. For more information, see *Programming Hardware Manufacturers*.

## IEEE Std. 1149.1 (JTAG) Boundary-Scan Support

MAX 7000A devices include the JTAG BST circuitry defined by IEEE Std. 1149.1-1990. [Table 4](#) describes the JTAG instructions supported by MAX 7000A devices. The pin-out tables starting on [page 41](#) of this data sheet show the location of the JTAG control pins for each device. If the JTAG interface is not required, the JTAG pins are available as user I/O pins.

**Table 4. MAX 7000A JTAG Instructions**

JTAG Instruction	Description
SAMPLE/PRELOAD	Allows a snapshot of signals at the device pins to be captured and examined during normal device operation, and permits an initial data pattern output at the device pins.
EXTEST	Allows the external circuitry and board-level interconnections to be tested by forcing a test pattern at the output pins and capturing test results at the input pins.
BYPASS	Places the 1-bit bypass register between the TDI and TDO pins, which allows the BST data to pass synchronously through a selected device to adjacent devices during normal device operation.
IDCODE	Selects the IDCODE register and places it between the TDI and TDO pins, allowing the IDCODE to be serially shifted out of TDO.
USERCODE	Selects the 32-bit USERCODE register and places it between the TDI and TDO pins, allowing the USERCODE value to be shifted out of TDO. USERCODE instructions are available for MAX 7000AE devices only.
UESCODE	These instructions select the user electronic signature (UESCODE) and allow the UESCODE to be shifted out of TDO. UESCODE instructions are available for EPM7128A and EPM7256A devices only.
ISP Instructions	These instructions are used when programming MAX 7000A devices via the JTAG ports with the BitBlaster, ByteBlaster, ByteBlasterMV, or MasterBlaster download cable, or using a Jam File (.jam), Jam Byte-Code File (.jbc), or Serial Vector Format File (.svf) via an embedded processor or test equipment.



The instruction register length of MAX 7000A devices is 10 bits. The UES register length in MAX 7000A devices is 16 bits. The MAX 7000AE USERCODE register length is 32 bits. Tables 5 and 6 show the boundary-scan register length and device IDCODE information for MAX 7000A devices.

**Table 5. MAX 7000A Boundary-Scan Register Length**

Device	Boundary-Scan Register Length
EPM7032AE	96
EPM7064AE	192
EPM7128A	288
EPM7128AE	288
EPM7256A	480
EPM7256AE	480
EPM7512AE	624

**Table 6. 32-Bit MAX 7000A Device IDCODE** *Note (1)*

Device	IDCODE (32 bits)			
	Version (4 Bits)	Part Number (16 Bits)	Manufacturer's Identity (11 Bits)	1 (1 Bit) (2)
EPM7032AE	0001	0111 0000 0011 0010	00001101110	1
EPM7064AE	0001	0111 0000 0110 0100	00001101110	1
EPM7128A	0000	0111 0001 0010 1000	00001101110	1
EPM7128AE	0001	0111 0001 0010 1000	00001101110	1
EPM7256A	0000	0111 0010 0101 0110	00001101110	1
EPM7256AE	0001	0111 0010 0101 0110	00001101110	1
EPM7512AE	0001	0111 0101 0001 0010	00001101110	1

**Notes to tables:**

- (1) The most significant bit (MSB) is on the left.
- (2) The least significant bit (LSB) for all JTAG IDCODEs is 1.



See [Application Note 39 \(IEEE 1149.1 \(JTAG\) Boundary-Scan Testing in Altera Devices\)](#) for more information on JTAG BST.

Figure 8 shows the timing information for the JTAG signals.

**Figure 8. MAX 7000A JTAG Waveforms**

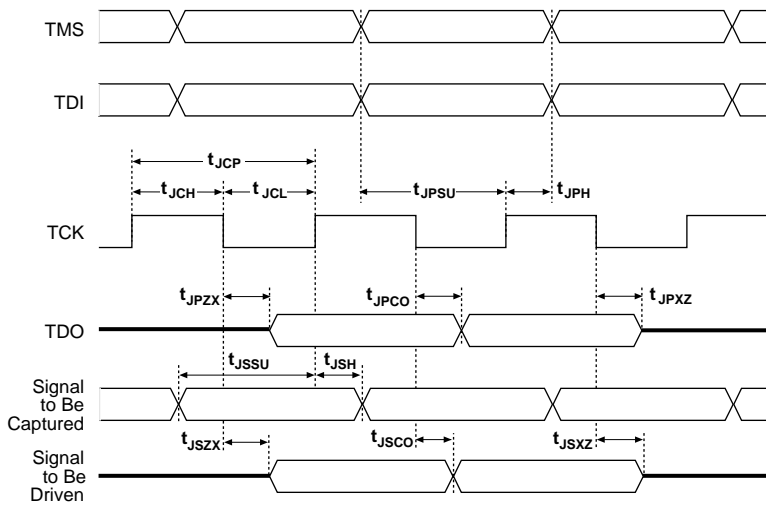

Table 7 shows the JTAG timing parameters and values for MAX 7000A devices.

**Table 7. JTAG Timing Parameters & Values for MAX 7000A Devices**

Symbol	Parameter	Min	Max	Unit
$t_{JCP}$	TCK clock period	100		ns
$t_{JCH}$	TCK clock high time	50		ns
$t_{JCL}$	TCK clock low time	50		ns
$t_{JPSU}$	JTAG port setup time	20		ns
$t_{JPH}$	JTAG port hold time	45		ns
$t_{JPCO}$	JTAG port clock to output		25	ns
$t_{JPZX}$	JTAG port high impedance to valid output		25	ns
$t_{JPXZ}$	JTAG port valid output to high impedance		25	ns
$t_{JSSU}$	Capture register setup time	20		ns
$t_{JSH}$	Capture register hold time	45		ns
$t_{JSCO}$	Update register clock to output		25	ns
$t_{JSZX}$	Update register high impedance to valid output		25	ns
$t_{JSXZ}$	Update register valid output to high impedance		25	ns

## Programmable Speed/Power Control

MAX 7000A devices offer a power-saving mode that supports low-power operation across user-defined signal paths or the entire device. This feature allows total power dissipation to be reduced by 50% or more, because most logic applications require only a small fraction of all gates to operate at maximum frequency.

The designer can program each individual macrocell in a MAX 7000A device for either high-speed or low-power operation. As a result, speed-critical paths in the design can run at high speed, while the remaining paths can operate at reduced power. Macrocells that run at low power incur a nominal timing delay adder ( $t_{LPA}$ ) for the  $t_{LAD}$ ,  $t_{LAC}$ ,  $t_{IC}$ ,  $t_{EN}$ ,  $t_{SEXP}$ ,  $t_{ACL}$ , and  $t_{CPPW}$  parameters.

## Output Configuration

MAX 7000A device outputs can be programmed to meet a variety of system-level requirements.

### MultiVolt I/O Interface

The MAX 7000A device architecture supports the MultiVolt I/O interface feature, which allows MAX 7000A devices to connect to systems with differing supply voltages. MAX 7000A devices in all packages can be set for 2.5-V, 3.3-V, or 5.0-V I/O pin operation. These devices have one set of  $V_{CC}$  pins for internal operation and input buffers ( $V_{CCINT}$ ), and another set for I/O output drivers ( $V_{CCIO}$ ).

The  $V_{CCIO}$  pins can be connected to either a 3.3-V or 2.5-V power supply, depending on the output requirements. When the  $V_{CCIO}$  pins are connected to a 2.5-V power supply, the output levels are compatible with 2.5-V systems. When the  $V_{CCIO}$  pins are connected to a 3.3-V power supply, the output high is at 3.3 V and is therefore compatible with 3.3-V or 5.0-V systems. Devices operating with  $V_{CCIO}$  levels lower than 3.0 V incur a nominally greater timing delay of  $t_{OD2}$  instead of  $t_{OD1}$ . Inputs can always be driven by 2.5-V, 3.3-V, or 5.0-V signals.

Table 8 describes the MAX 7000A MultiVolt I/O support.

$V_{CCIO}$ Voltage	Input Signal (V)			Output Signal (V)		
	2.5	3.3	5.0	2.5	3.3	5.0
2.5	✓	✓	✓	✓		
3.3	✓	✓	✓		✓	✓

## Open-Drain Output Option

MAX 7000A devices provide an optional open-drain (equivalent to open-collector) output for each I/O pin. This open-drain output enables the device to provide system-level control signals (e.g., interrupt and write enable signals) that can be asserted by any of several devices. It can also provide an additional wired-OR plane.

Open-drain output pins on MAX 7000A devices (with a pull-up resistor to the 5.0-V supply) can drive 5.0-V CMOS input pins that require a  $V_{IH}$  of 3.5 V. When the open-drain pin is active, it will drive low. When the pin is inactive, the trace will be pulled up to 5.0 V by the resistor. The open-drain pin will only drive low or tri-state; it will never drive high. The rise time is dependent on the value of the pull-up resistor and load impedance. The  $I_{OL}$  current specification should be considered when selecting a pull-up resistor.

## Programmable Ground Pins

Each unused I/O pin on MAX 7000A devices may be used as an additional ground pin. In EPM7128A and EPM7256A devices, utilizing unused I/O pins as additional ground pins requires using the associated macrocell. In MAX 7000AE devices, this programmable ground feature does not require the use of the associated macrocell; therefore, the buried macrocell is still available for user logic.

## Slew-Rate Control

The output buffer for each MAX 7000A I/O pin has an adjustable output slew rate that can be configured for low-noise or high-speed performance. A faster slew rate provides high-speed transitions for high-performance systems. However, these fast transitions may introduce noise transients into the system. A slow slew rate reduces system noise, but adds a nominal delay of 4 to 5 ns. When the configuration cell is turned off, the slew rate is set for low-noise performance. Each I/O pin has an individual EEPROM bit that controls the slew rate, allowing designers to specify the slew rate on a pin-by-pin basis. The slew rate control affects both the rising and falling edges of the output signal.

## Power Sequencing & Hot-Socketing

Because MAX 7000A family devices can be used in a mixed-voltage environment, they have been designed specifically to tolerate any possible power-up sequence. The  $V_{CCIO}$  and  $V_{CCINT}$  power planes can be powered in any order.

Signals can be driven into MAX 7000A devices before and during power up without damaging the device. Additionally, MAX 7000A devices do not drive out during power up. Once operating conditions are reached, MAX 7000A devices operate as specified by the user.

## Design Security

All MAX 7000A devices contain a programmable security bit that controls access to the data programmed into the device. When this bit is programmed, a design implemented in the device cannot be copied or retrieved. This feature provides a high level of design security, because programmed data within EEPROM cells is invisible. The security bit that controls this function, as well as all other programmed data, is reset only when the device is reprogrammed.

## Generic Testing

MAX 7000A devices are fully functionally tested. Complete testing of each programmable EEPROM bit and all internal logic elements ensures 100% programming yield. AC test measurements are taken under conditions equivalent to those shown in Figure 9. Test patterns can be used and then erased during early stages of the production flow.

**Figure 9. MAX 7000A AC Test Conditions**

*Power supply transients can affect AC measurements. Simultaneous transitions of multiple outputs should be avoided for accurate measurement. Threshold tests must not be performed under AC conditions. Large-amplitude, fast-ground-current transients normally occur as the device outputs discharge the load capacitances. When these transients flow through the parasitic inductance between the device ground pin and the test system ground, significant reductions in observable noise immunity can result. Numbers in brackets are for 2.5-V outputs. Numbers without brackets are for 3.3-V devices or outputs.*

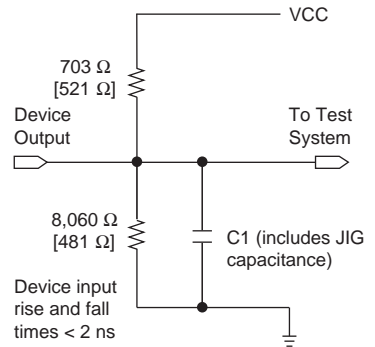

## Operating Conditions

Tables 9 through 12 provide information on absolute maximum ratings, recommended operating conditions, operating conditions, and capacitance for MAX 7000A devices.

**Table 9. MAX 7000A Device Absolute Maximum Ratings** Note (1)

Symbol	Parameter	Conditions	Min	Max	Unit
$V_{CC}$	Supply voltage	With respect to ground (2)	-0.5	4.6	V
$V_I$	DC input voltage		-2.0	5.75	V
$I_{OUT}$	DC output current, per pin		-25	25	mA
$T_{STG}$	Storage temperature	No bias	-65	150	°C
$T_A$	Ambient temperature	Under bias	-65	135	°C
$T_J$	Junction temperature	BGA, FineLine BGA, PQFP, and TQFP packages, under bias		135	°C

**Table 10. MAX 7000A Device Recommended Operating Conditions**

Symbol	Parameter	Conditions	Min	Max	Unit
$V_{CCINT}$	Supply voltage for internal logic and input buffers	(3)	3.0	3.6	V
$V_{CCIO}$	Supply voltage for output drivers, 3.3-V operation	(3)	3.0	3.6	V
	Supply voltage for output drivers, 2.5-V operation	(3)	2.3	2.7	V
$V_{CCISP}$	Supply voltage during in-system programming		3.0	3.6	V
$V_I$	Input voltage	(4)	-0.5	5.75	V
$V_O$	Output voltage		0	$V_{CCIO}$	V
$T_A$	Ambient temperature	For commercial use	0	70	°C
		For industrial use	-40	85	°C
$T_J$	Junction temperature	For commercial use	0	90	°C
		For industrial use	-40	105	°C
$t_R$	Input rise time			40	ns
$t_F$	Input fall time			40	ns

**Table 11. MAX 7000A Device DC Operating Conditions** *Note (5)*

Symbol	Parameter	Conditions	Min	Max	Unit
$V_{IH}$	High-level input voltage		1.7	5.75	V
$V_{IL}$	Low-level input voltage		-0.5	0.8	V
$V_{OH}$	3.3-V high-level TTL output voltage	$I_{OH} = -8$ mA DC, $V_{CCIO} = 3.00$ V (6)	2.4		V
		$I_{OH} = -0.1$ mA DC, $V_{CCIO} = 3.00$ V (6)	$V_{CCIO} - 0.2$		V
	2.5-V high-level output voltage	$I_{OH} = -100$ $\mu$ A DC, $V_{CCIO} = 2.30$ V (6)	2.1		V
		$I_{OH} = -1$ mA DC, $V_{CCIO} = 2.30$ V (6)	2.0		V
		$I_{OH} = -2$ mA DC, $V_{CCIO} = 2.30$ V (6)	1.7		V
$V_{OL}$	3.3-V low-level TTL output voltage	$I_{OL} = 8$ mA DC, $V_{CCIO} = 3.00$ V (7)		0.45	V
		$I_{OL} = 0.1$ mA DC, $V_{CCIO} = 3.00$ V (7)		0.2	V
	2.5-V low-level output voltage	$I_{OL} = 100$ $\mu$ A DC, $V_{CCIO} = 2.30$ V (7)		0.2	V
		$I_{OL} = 1$ mA DC, $V_{CCIO} = 2.30$ V (7)		0.4	V
		$I_{OL} = 2$ mA DC, $V_{CCIO} = 2.30$ V (7)		0.7	V
$I_I$	Input leakage current	$V_I = V_{CCINT}$ or ground	-10	10	$\mu$ A
$I_{OZ}$	Tri-state output off-state current	$V_O = V_{CCINT}$ or ground	-10	10	$\mu$ A
$R_{ISP}$	Value of I/O pin pull-up resistor during programming in-system or during power-up	$V_{CCIO} = 3.0$ to $3.6$ V (8)	20	50	k $\Omega$
		$V_{CCIO} = 2.3$ to $2.7$ V (8)	30	80	k $\Omega$
		$V_{CCIO} = 2.3$ to $3.6$ V (9)	20	74	k $\Omega$

**Table 12. MAX 7000A Device Capacitance** *Note (10)*

Symbol	Parameter	Conditions	Min	Max	Unit
$C_{IN}$	Input pin capacitance	$V_{IN} = 0$ V, $f = 1.0$ MHz		8	pF
$C_{I/O}$	I/O pin capacitance	$V_{OUT} = 0$ V, $f = 1.0$ MHz		8	pF

**Notes to tables:**

- (1) See the *Operating Requirements for Altera Devices Data Sheet*.
- (2) Minimum DC input voltage is  $-0.5$  V. During transitions, the inputs may undershoot to  $-2.0$  V for input currents less than 100 mA and periods shorter than 20 ns.
- (3)  $V_{CC}$  must rise monotonically.
- (4) In MAX 7000AE devices, all pins, including dedicated inputs, I/O pins, and JTAG pins, may be driven before  $V_{CCINT}$  and  $V_{CCIO}$  are powered.
- (5) These values are specified in [Table 10 on page 22](#).
- (6) The parameter is measured with 50% of the outputs each sourcing the specified current. The  $I_{OH}$  parameter refers to high-level TTL or CMOS output current.
- (7) The parameter is measured with 50% of the outputs each sinking the specified current. The  $I_{OL}$  parameter refers to low-level TTL or CMOS output current.
- (8) For EPM7128A and EPM7256A devices, this pull-up exists while a device is programmed in-system.
- (9) For MAX 7000AE devices, this pull-up exists while devices are programmed in-system and in unprogrammed devices during power-up.
- (10) Capacitance is measured at 25 °C and is sample-tested only. The  $\text{OE}1$  pin (high-voltage pin during programming) has a maximum capacitance of 20 pF.

Figure 10 shows the typical output drive characteristics of MAX 7000A devices.

**Figure 10. Output Drive Characteristics of MAX 7000A Devices**

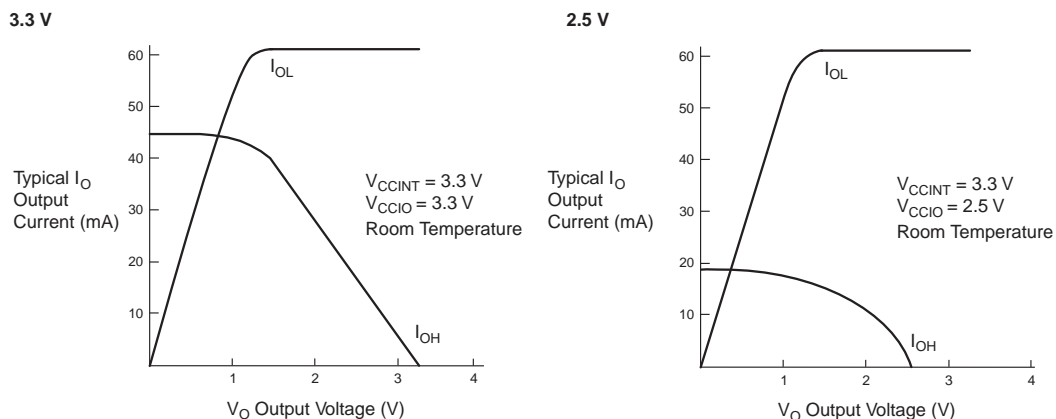

## Timing Model

MAX 7000A device timing can be analyzed with the Quartus and MAX+PLUS II software, with a variety of popular industry-standard EDA simulators and timing analyzers, or with the timing model shown in [Figure 11](#). MAX 7000A devices have predictable internal delays that enable the designer to determine the worst-case timing of any design. The MAX+PLUS II software provides timing simulation, point-to-point delay prediction, and detailed timing analysis for device-wide performance evaluation.



Figure 11. MAX 7000A Timing Model

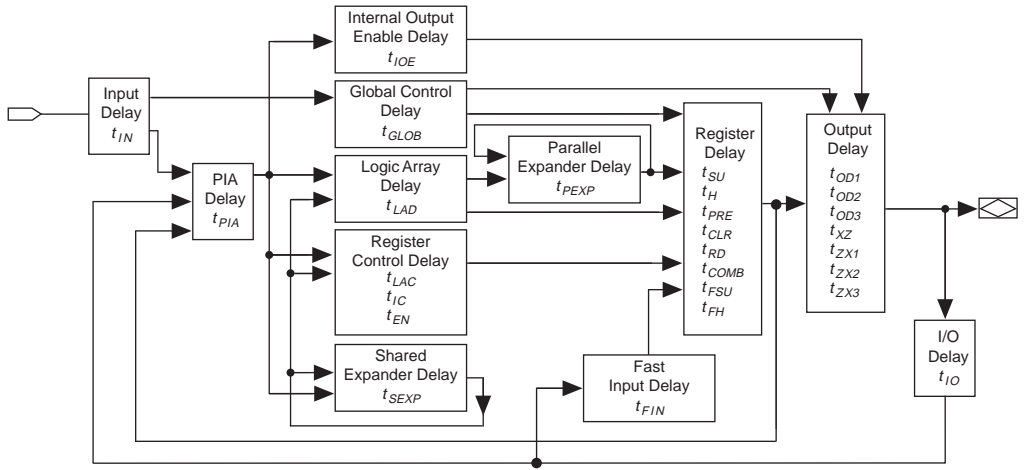

The timing characteristics of any signal path can be derived from the timing model and parameters of a particular device. External timing parameters, which represent pin-to-pin timing delays, can be calculated as the sum of internal parameters. Figure 12 shows the timing relationship between internal and external delay parameters.



See [Application Note 94 \(Understanding MAX 7000 Timing\)](#) for more information.

Figure 12. MAX 7000A Switching Waveforms

$t_R$  &  $t_F < 2$  ns. Inputs are driven at 3 V for a logic high and 0 V for a logic low. All timing characteristics are measured at 1.5 V.

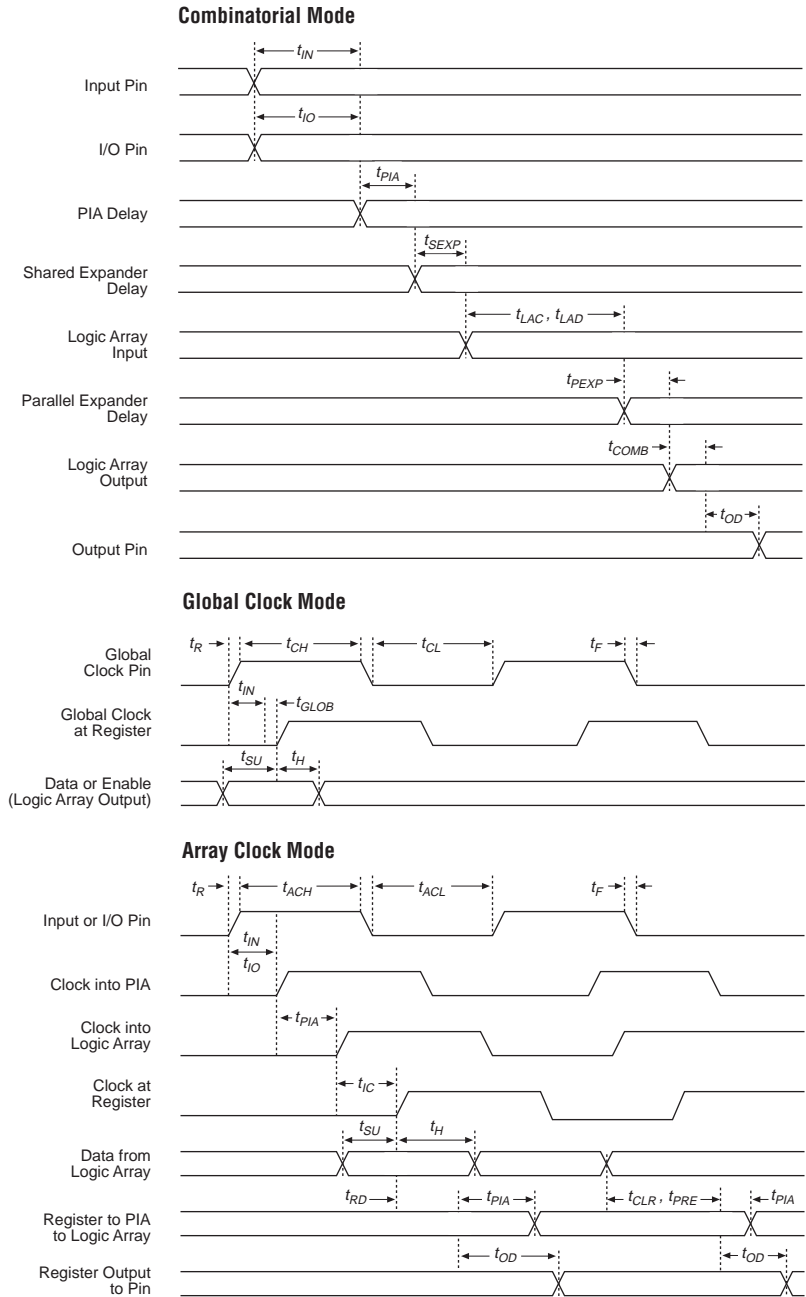

Tables 13 through 20 show EPM7128A, EPM7256A, and MAX 7000AE AC operating conditions.

**Table 13. EPM7128A External Timing Parameters** *Note (1)*

Symbol	Parameter	Conditions	Speed Grade								Unit
			-6		-7		-10		-12		
			Min	Max	Min	Max	Min	Max	Min	Max	
$t_{PD1}$	Input to non-registered output	C1 = 35 pF (2)		6.0		7.5		10.0		12.0	ns
$t_{PD2}$	I/O input to non-registered output	C1 = 35 pF (2)		6.0		7.5		10.0		12.0	ns
$t_{SU}$	Global clock setup time	(2)	4.2		5.3		7.0		8.5		ns
$t_H$	Global clock hold time	(2)	0.0		0.0		0.0		0.0		ns
$t_{FSU}$	Global clock setup time of fast input		2.5		3.0		3.0		3.0		ns
$t_{FH}$	Global clock hold time of fast input		0.0		0.0		0.0		0.0		ns
$t_{CO1}$	Global clock to output delay	C1 = 35 pF	1.0	3.7	1.0	4.6	1.0	6.1	1.0	7.3	ns
$t_{CH}$	Global clock high time		3.0		3.0		4.0		5.0		ns
$t_{CL}$	Global clock low time		3.0		3.0		4.0		5.0		ns
$t_{ASU}$	Array clock setup time	(2)	1.9		2.4		3.1		3.8		ns
$t_{AH}$	Array clock hold time	(2)	1.5		2.2		3.3		4.3		ns
$t_{ACO1}$	Array clock to output delay	C1 = 35 pF (2)	1.0	6.0	1.0	7.5	1.0	10.0	1.0	12.0	ns
$t_{ACH}$	Array clock high time		3.0		3.0		4.0		5.0		ns
$t_{ACL}$	Array clock low time		3.0		3.0		4.0		5.0		ns
$t_{CPPW}$	Minimum pulse width for clear and preset	(3)	3.0		3.0		4.0		5.0		ns
$t_{CNT}$	Minimum global clock period	(2)		6.9		8.6		11.5		13.8	ns
$f_{CNT}$	Maximum internal global clock frequency	(2), (4)	144.9		116.3		87.0		72.5		MHz
$t_{ACNT}$	Minimum array clock period	(2)		6.9		8.6		11.5		13.8	ns
$f_{ACNT}$	Maximum internal array clock frequency	(2), (4)	144.9		116.3		87		72.5		MHz
$f_{MAX}$	Maximum clock frequency	(5)	166.7		166.7		125.0		100.0		MHz

Table 14. EPM7128A Internal Timing Parameters (Part 1 of 2)

Symbol	Parameter	Conditions	Speed Grade								Unit
			-6		-7		-10		-12		
			Min	Max	Min	Max	Min	Max	Min	Max	
$t_{IN}$	Input pad and buffer delay			0.6		0.7		0.9		1.1	ns
$t_{IO}$	I/O input pad and buffer delay			0.6		0.7		0.9		1.1	ns
$t_{FIN}$	Fast input delay			2.7		3.1		3.6		3.9	ns
$t_{SEXP}$	Shared expander delay			2.5		3.2		4.3		5.1	ns
$t_{PEXP}$	Parallel expander delay			0.7		0.8		1.1		1.3	ns
$t_{LAD}$	Logic array delay			2.4		3.0		4.1		4.9	ns
$t_{LAC}$	Logic control array delay			2.4		3.0		4.1		4.9	ns
$t_{IOE}$	Internal output enable delay			0.0		0.0		0.0		0.0	ns
$t_{OD1}$	Output buffer and pad delay, slow slew rate = off $V_{CCIO} = 3.3\text{ V}$	$C1 = 35\text{ pF}$		0.4		0.6		0.7		0.9	ns
$t_{OD2}$	Output buffer and pad delay, slow slew rate = off $V_{CCIO} = 2.5\text{ V}$	$C1 = 35\text{ pF}$ (6)		0.9		1.1		1.2		1.4	ns
$t_{OD3}$	Output buffer and pad delay, slow slew rate = on $V_{CCIO} = 2.5\text{ V}$ or $3.3\text{ V}$	$C1 = 35\text{ pF}$		5.4		5.6		5.7		5.9	ns
$t_{ZX1}$	Output buffer enable delay, slow slew rate = off $V_{CCIO} = 3.3\text{ V}$	$C1 = 35\text{ pF}$		4.0		4.0		5.0		5.0	ns
$t_{ZX2}$	Output buffer enable delay, slow slew rate = off $V_{CCIO} = 2.5\text{ V}$	$C1 = 35\text{ pF}$ (6)		4.5		4.5		5.5		5.5	ns
$t_{ZX3}$	Output buffer enable delay, slow slew rate = on $V_{CCIO} = 3.3\text{ V}$	$C1 = 35\text{ pF}$		9.0		9.0		10.0		10.0	ns
$t_{XZ}$	Output buffer disable delay	$C1 = 5\text{ pF}$		4.0		4.0		5.0		5.0	ns
$t_{SU}$	Register setup time		1.9		2.4		3.1		3.8		ns
$t_H$	Register hold time		1.5		2.2		3.3		4.3		ns
$t_{FSU}$	Register setup time of fast input		0.8		1.1		1.1		1.1		ns
$t_{FH}$	Register hold time of fast input		1.7		1.9		1.9		1.9		ns

**Table 14. EPM7128A Internal Timing Parameters (Part 2 of 2)**

Symbol	Parameter	Conditions	Speed Grade								Unit
			-6		-7		-10		-12		
			Min	Max	Min	Max	Min	Max	Min	Max	
$t_{RD}$	Register delay			1.7		2.1		2.8		3.3	ns
$t_{COMB}$	Combinatorial delay			1.7		2.1		2.8		3.3	ns
$t_{IC}$	Array clock delay			2.4		3.0		4.1		4.9	ns
$t_{EN}$	Register enable time			2.4		3.0		4.1		4.9	ns
$t_{GLOB}$	Global control delay			1.0		1.2		1.7		2.0	ns
$t_{PRE}$	Register preset time			3.1		3.9		5.2		6.2	ns
$t_{CLR}$	Register clear time			3.1		3.9		5.2		6.2	ns
$t_{PIA}$	PIA delay	(2)		0.9		1.1		1.5		1.8	ns
$t_{LPA}$	Low-power adder	(7)		11.0		10.0		10.0		10.0	ns

Table 15. EPM7256A External Timing Parameters *Note (1)*

Symbol	Parameter	Conditions	Speed Grade								Unit
			-6		-7		-10		-12		
			Min	Max	Min	Max	Min	Max	Min	Max	
$t_{PD1}$	Input to non-registered output	C1 = 35 pF (2)		6.0		7.5		10.0		12.0	ns
$t_{PD2}$	I/O input to non-registered output	C1 = 35 pF (2)		6.0		7.5		10.0		12.0	ns
$t_{SU}$	Global clock setup time	(2)	3.7		4.6		6.2		7.4		ns
$t_H$	Global clock hold time	(2)	0.0		0.0		0.0		0.0		ns
$t_{FSU}$	Global clock setup time of fast input		2.5		3.0		3.0		3.0		ns
$t_{FH}$	Global clock hold time of fast input		0.0		0.0		0.0		0.0		ns
$t_{CO1}$	Global clock to output delay	C1 = 35 pF	1.0	3.3	1.0	4.2	1.0	5.5	1.0	6.6	ns
$t_{CH}$	Global clock high time		3.0		3.0		4.0		4.0		ns
$t_{CL}$	Global clock low time		3.0		3.0		4.0		4.0		ns
$t_{ASU}$	Array clock setup time	(2)	0.8		1.0		1.4		1.6		ns
$t_{AH}$	Array clock hold time	(2)	1.9		2.7		4.0		5.1		ns
$t_{ACO1}$	Array clock to output delay	C1 = 35 pF (2)	1.0	6.2	1.0	7.8	1.0	10.3	1.0	12.4	ns
$t_{ACH}$	Array clock high time		3.0		3.0		4.0		4.0		ns
$t_{ACL}$	Array clock low time		3.0		3.0		4.0		4.0		ns
$t_{CPPW}$	Minimum pulse width for clear and preset	(3)	3.0		3.0		4.0		4.0		ns
$t_{CNT}$	Minimum global clock period	(2)		6.4		8.0		10.7		12.8	ns
$f_{CNT}$	Maximum internal global clock frequency	(2), (4)	156.3		125.0		93.5		78.1		MHz
$t_{ACNT}$	Minimum array clock period	(2)		6.4		8.0		10.7		12.8	ns
$f_{ACNT}$	Maximum internal array clock frequency	(2), (4)	156.3		125.0		93.5		78.1		MHz
$f_{MAX}$	Maximum clock frequency	(2), (5)	166.7		166.7		125.0		125.0		MHz

Table 16. EPM7256A Internal Timing Parameters (Part 1 of 2)

Symbol	Parameter	Conditions	Speed Grade								Unit
			-6		-7		-10		-12		
			Min	Max	Min	Max	Min	Max	Min	Max	
$t_{IN}$	Input pad and buffer delay			0.3		0.4		0.5		0.6	ns
$t_{IO}$	I/O input pad and buffer delay			0.3		0.4		0.5		0.6	ns
$t_{FIN}$	Fast input delay			2.4		3.0		3.4		3.8	ns
$t_{SEXP}$	Shared expander delay			2.8		3.5		4.7		5.6	ns
$t_{PEXP}$	Parallel expander delay			0.5		0.6		0.8		1.0	ns
$t_{LAD}$	Logic array delay			2.5		3.1		4.2		5.0	ns
$t_{LAC}$	Logic control array delay			2.5		3.1		4.2		5.0	ns
$t_{IOE}$	Internal output enable delay			0.2		0.3		0.4		0.5	ns
$t_{OD1}$	Output buffer and pad delay, slow slew rate = off $V_{CCIO} = 3.3\text{ V}$	$C1 = 35\text{ pF}$		0.3		0.4		0.5		0.6	ns
$t_{OD2}$	Output buffer and pad delay, slow slew rate = off $V_{CCIO} = 2.5\text{ V}$	$C1 = 35\text{ pF}$ (6)		0.8		0.9		1.0		1.1	ns
$t_{OD3}$	Output buffer and pad delay slow slew rate = on $V_{CCIO} = 2.5\text{ V}$ or $3.3\text{ V}$	$C1 = 35\text{ pF}$		5.3		5.4		5.5		5.6	ns
$t_{ZX1}$	Output buffer enable delay slow slew rate = off $V_{CCIO} = 3.3\text{ V}$	$C1 = 35\text{ pF}$		4.0		4.0		5.0		5.0	ns
$t_{ZX2}$	Output buffer enable delay slow slew rate = off $V_{CCIO} = 2.5\text{ V}$	$C1 = 35\text{ pF}$ (6)		4.5		4.5		5.5		5.5	ns
$t_{ZX3}$	Output buffer enable delay slow slew rate = on $V_{CCIO} = 2.5\text{ V}$ or $3.3\text{ V}$	$C1 = 35\text{ pF}$		9.0		9.0		10.0		10.0	ns
$t_{XZ}$	Output buffer disable delay	$C1 = 5\text{ pF}$		4.0		4.0		5.0		5.0	ns
$t_{SU}$	Register setup time		1.0		1.3		1.7		2.0		ns
$t_H$	Register hold time		1.7		2.4		3.7		4.7		ns

**Table 16. EPM7256A Internal Timing Parameters (Part 2 of 2)**

Symbol	Parameter	Conditions	Speed Grade								Unit
			-6		-7		-10		-12		
			Min	Max	Min	Max	Min	Max	Min	Max	
$t_{FSU}$	Register setup time of fast input		1.2		1.4		1.4		1.4		ns
$t_{FH}$	Register hold time of fast input		1.3		1.6		1.6		1.6		ns
$t_{RD}$	Register delay			1.6		2.0		2.7		3.2	ns
$t_{COMB}$	Combinatorial delay			1.6		2.0		2.7		3.2	ns
$t_{IC}$	Array clock delay			2.7		3.4		4.5		5.4	ns
$t_{EN}$	Register enable time			2.5		3.1		4.2		5.0	ns
$t_{GLOB}$	Global control delay			1.1		1.4		1.8		2.2	ns
$t_{PRE}$	Register preset time			2.3		2.9		3.8		4.6	ns
$t_{CLR}$	Register clear time			2.3		2.9		3.8		4.6	ns
$t_{PIA}$	PIA delay	(2)		1.3		1.6		2.1		2.6	ns
$t_{LPA}$	Low-power adder	(7)		11.0		10.0		10.0		10.0	ns



Table 17. MAX 7000AE External Timing Parameters *Notes (1), (8)*

Symbol	Parameter	Conditions	Speed Grade								Unit
			-4		-5				-6		
			Min	Max	EPM7128AE		EPM7256AE		Min	Max	
					Min	Max	Min	Max			
t <sub>PD1</sub>	Input to non-registered output	C1 = 35 pF (2)		4.5		5.0		5.5		6.0	ns
t <sub>PD2</sub>	I/O input to non-registered output	C1 = 35 pF (2)		4.5		5.0		5.5		6.0	ns
t <sub>SU</sub>	Global clock setup time	(2)	3.0		3.2		3.5		3.7		ns
t <sub>H</sub>	Global clock hold time	(2)	0.0		0.0		0.0		0.0		ns
t <sub>FSU</sub>	Global clock setup time of fast input		2.5		2.5		2.5		2.5		ns
t <sub>FH</sub>	Global clock hold time of fast input		0.0		0.0		0.0		0.0		ns
t <sub>CO1</sub>	Global clock to output delay	C1 = 35 pF	1.0	2.8	1.0	3.0	1.0	3.2	1.0	3.3	ns
t <sub>CH</sub>	Global clock high time		2.0		2.0		2.5		3.0		ns
t <sub>CL</sub>	Global clock low time		2.0		2.0		2.5		3.0		ns
t <sub>ASU</sub>	Array clock setup time	(2)	1.4		1.0		0.9		0.8		ns
t <sub>AH</sub>	Array clock hold time	(2)	0.8		0.8		1.6		1.9		ns
t <sub>ACO1</sub>	Array clock to output delay	C1 = 35 pF (2)	1.0	4.4	1.0	5.2	1.0	5.8	1.0	6.2	ns
t <sub>ACH</sub>	Array clock high time		2.0		2.0		2.5		3.0		ns
t <sub>ACL</sub>	Array clock low time		2.0		2.0		2.5		3.0		ns
t <sub>CPPW</sub>	Minimum pulse width for clear and preset	(3)	2.0		2.0		2.5		3.0		ns
t <sub>CNT</sub>	Minimum global clock period	(2)		5.2		5.5		6.1		6.4	ns
f <sub>CNT</sub>	Maximum internal global clock frequency	(2), (4)	192.3		181.8		163.9		156.3		MHz
t <sub>ACNT</sub>	Minimum array clock period	(2)		5.2		5.5		6.1		6.4	ns
f <sub>ACNT</sub>	Maximum internal array clock frequency	(2), (4)	192.3		181.8		163.9		156.3		MHz
f <sub>MAX</sub>	Maximum clock frequency	(5)	250.0		250.0		200.0		166.7		MHz

**Table 18. MAX 7000AE Internal Timing Parameters (Part 1 of 2)** *Notes (1), (8)*

Symbol	Parameter	Conditions	Speed Grade								Unit
			-4		-5				-6		
			Min	Max	EPM7128AE		EPM7256AE		Min	Max	
$t_{IN}$	Input pad and buffer delay			0.3		0.3		0.3		0.3	ns
$t_{IO}$	I/O input pad and buffer delay			0.3		0.3		0.3		0.3	ns
$t_{FIN}$	Fast input delay			2.6		2.6		2.5		2.4	ns
$t_{SEXP}$	Shared expander delay			1.9		2.4		2.6		2.8	ns
$t_{PEXP}$	Parallel expander delay			0.5		0.6		0.6		0.5	ns
$t_{LAD}$	Logic array delay			1.9		2.5		2.5		2.5	ns
$t_{LAC}$	Logic control array delay			1.8		2.3		2.4		2.5	ns
$t_{IOE}$	Internal output enable delay			0.0		0.0		0.1		0.2	ns
$t_{OD1}$	Output buffer and pad delay slow slew rate = off $V_{CCIO} = 3.3\text{ V}$	$C1 = 35\text{ pF}$		0.3		0.4		0.3		0.3	ns
$t_{OD2}$	Output buffer and pad delay slow slew rate = off $V_{CCIO} = 2.5\text{ V}$	$C1 = 35\text{ pF}$ (6)		0.8		0.9		0.8		0.8	ns
$t_{OD3}$	Output buffer and pad delay slow slew rate = on $V_{CCIO} = 2.5\text{ V}$ or $3.3\text{ V}$	$C1 = 35\text{ pF}$		5.3		5.4		5.3		5.3	ns
$t_{ZX1}$	Output buffer enable delay slow slew rate = off $V_{CCIO} = 3.3\text{ V}$	$C1 = 35\text{ pF}$		4.0		4.0		4.0		4.0	ns
$t_{ZX2}$	Output buffer enable delay slow slew rate = off $V_{CCIO} = 2.5\text{ V}$	$C1 = 35\text{ pF}$ (6)		4.5		4.5		4.5		4.5	ns
$t_{ZX3}$	Output buffer enable delay slow slew rate = on $V_{CCIO} = 2.5\text{ V}$ or $3.3\text{ V}$	$C1 = 35\text{ pF}$		9.0		9.0		9.0		9.0	ns

Table 18. MAX 7000AE Internal Timing Parameters (Part 2 of 2) Notes (1), (8)

Symbol	Parameter	Conditions	Speed Grade								Unit
			-4		-5				-6		
			Min	Max	EPM7128AE		EPM7256AE		Min	Max	
					Min	Max	Min	Max			
$t_{XZ}$	Output buffer disable delay	C1 = 5 pF		4.0		4.0		4.0		4.0	ns
$t_{SU}$	Register setup time		1.4		0.8		1.0		1.0		ns
$t_H$	Register hold time		0.8		1.0		1.5		1.7		ns
$t_{FSU}$	Register setup time of fast input		0.9		0.8		1.1		1.2		ns
$t_{FH}$	Register hold time of fast input		1.6		1.7		1.4		1.3		ns
$t_{RD}$	Register delay			1.2		1.4		1.5		1.6	ns
$t_{COMB}$	Combinatorial delay			1.3		1.0		1.3		1.6	ns
$t_{IC}$	Array clock delay			1.9		2.3		2.6		2.7	ns
$t_{EN}$	Register enable time			1.8		2.3		2.4		2.5	ns
$t_{GLOB}$	Global control delay			1.0		0.9		1.1		1.1	ns
$t_{PRE}$	Register preset time			2.3		2.6		2.5		2.3	ns
$t_{CLR}$	Register clear time			2.3		2.6		2.5		2.3	ns
$t_{PIA}$	PIA delay	(2)		0.7		0.8		1.1		1.3	ns
$t_{LPA}$	Low-power adder	(7)		12.0		12.0		12.0		11.0	ns

**Table 19. MAX 7000AE External Timing Parameters** *Notes (1), (8)*

Symbol	Parameter	Conditions	Speed Grade						Unit
			-7		-10		-12		
			Min	Max	Min	Max	Min	Max	
$t_{PD1}$	Input to non-registered output	C1 = 35 pF (2)		7.5		10.0		12.0	ns
$t_{PD2}$	I/O input to non-registered output	C1 = 35 pF (2)		7.5		10.0		12.0	ns
$t_{SU}$	Global clock setup time	(2)	4.9		6.6		7.8		ns
$t_H$	Global clock hold time	(2)	0.0		0.0		0.0		ns
$t_{FSU}$	Global clock setup time of fast input		3.0		3.0		3.0		ns
$t_{FH}$	Global clock hold time of fast input		0.0		0.0		0.0		ns
$t_{CO1}$	Global clock to output delay	C1 = 35 pF	1.0	4.5	1.0	5.9	1.0	7.1	ns
$t_{CH}$	Global clock high time		3.0		4.0		5.0		ns
$t_{CL}$	Global clock low time		3.0		4.0		5.0		ns
$t_{ASU}$	Array clock setup time	(2)	1.6		2.1		2.4		ns
$t_{AH}$	Array clock hold time	(2)	2.1		3.4		4.4		ns
$t_{ACO1}$	Array clock to output delay	C1 = 35 pF (2)	1.0	7.8	1.0	10.4	1.0	12.5	ns
$t_{ACH}$	Array clock high time		3.0		4.0		5.0		ns
$t_{ACL}$	Array clock low time		3.0		4.0		5.0		ns
$t_{CPPW}$	Minimum pulse width for clear and preset	(3)	3.0		4.0		5.0		ns
$t_{CNT}$	Minimum global clock period	(2)		8.4		11.2		13.3	ns
$f_{CNT}$	Maximum internal global clock frequency	(2), (4)	119.0		89.3		75.2		MHz
$t_{ACNT}$	Minimum array clock period	(2)		8.4		11.2		13.3	ns
$f_{ACNT}$	Maximum internal array clock frequency	(2), (4)	119.0		89.3		75.2		MHz
$f_{MAX}$	Maximum clock frequency	(5)	166.7		125.0		100.0		MHz

**Table 20. MAX 7000AE Internal Timing Parameters (Part 1 of 2)** *Notes (1), (8)*

Symbol	Parameter	Conditions	Speed Grade						Unit
			-7		-10		-12		
			Min	Max	Min	Max	Min	Max	
$t_{IN}$	Input pad and buffer delay			0.4		0.6		0.7	ns
$t_{IO}$	I/O input pad and buffer delay			0.4		0.6		0.7	ns
$t_{FIN}$	Fast input delay			3.3		3.7		4.1	ns

Table 20. MAX 7000AE Internal Timing Parameters (Part 2 of 2) Notes (1), (8)

Symbol	Parameter	Conditions	Speed Grade						Unit
			-7		-10		-12		
			Min	Max	Min	Max	Min	Max	
$t_{SEXP}$	Shared expander delay			3.6		4.9		5.9	ns
$t_{PEXP}$	Parallel expander delay			0.8		1.1		1.3	ns
$t_{LAD}$	Logic array delay			3.7		5.0		6.0	ns
$t_{LAC}$	Logic control array delay			3.4		4.6		5.6	ns
$t_{IOE}$	Internal output enable delay			0.0		0.0		0.0	ns
$t_{OD1}$	Output buffer and pad delay slow slew rate = off $V_{CCIO} = 3.3\text{ V}$	$C1 = 35\text{ pF}$		0.6		0.7		0.9	ns
$t_{OD2}$	Output buffer and pad delay slow slew rate = off $V_{CCIO} = 2.5\text{ V}$	$C1 = 35\text{ pF}$ (6)		1.1		1.2		1.4	ns
$t_{OD3}$	Output buffer and pad delay slow slew rate = on $V_{CCIO} = 2.5\text{ V}$ or $3.3\text{ V}$	$C1 = 35\text{ pF}$		5.6		5.7		5.9	ns
$t_{ZX1}$	Output buffer enable delay slow slew rate = off $V_{CCIO} = 3.3\text{ V}$	$C1 = 35\text{ pF}$		4.0		5.0		5.0	ns
$t_{ZX2}$	Output buffer enable delay slow slew rate = off $V_{CCIO} = 2.5\text{ V}$	$C1 = 35\text{ pF}$ (6)		4.5		5.5		5.5	ns
$t_{ZX3}$	Output buffer enable delay slow slew rate = on $V_{CCIO} = 2.5\text{ V}$ or $3.3\text{ V}$	$C1 = 35\text{ pF}$		9.0		10.0		10.0	ns
$t_{XZ}$	Output buffer disable delay	$C1 = 5\text{ pF}$		4.0		5.0		5.0	ns
$t_{SU}$	Register setup time		1.3		1.7		2.0		ns
$t_H$	Register hold time		2.4		3.8		4.8		ns
$t_{FSU}$	Register setup time of fast input		1.1		1.1		1.1		ns
$t_{FH}$	Register hold time of fast input		1.9		1.9		1.9		ns
$t_{RD}$	Register delay			2.1		2.8		3.3	ns
$t_{COMB}$	Combinatorial delay			1.5		2.0		2.4	ns
$t_{IC}$	Array clock delay			3.4		4.6		5.6	ns
$t_{EN}$	Register enable time			3.4		4.6		5.6	ns
$t_{GLOB}$	Global control delay			1.4		1.8		2.2	ns
$t_{PRE}$	Register preset time			3.9		5.2		6.2	ns
$t_{CLR}$	Register clear time			3.9		5.2		6.2	ns
$t_{PIA}$	PIA delay	(2)		1.3		1.7		2.0	ns
$t_{LPA}$	Low-power adder	(7)		10.0		10.0		10.0	ns

**Notes to tables:**

- (1) These values are specified in [Table 10 on page 22](#).
- (2) These values are specified for a PIA fan-out of one LAB (16 macrocells). For each additional LAB fan-out in these devices, add an additional 0.1 ns to the PIA timing value.
- (3) This minimum pulse width for preset and clear applies for both global clear and array controls. The  $t_{LPA}$  parameter must be added to this minimum width if the clear or reset signal incorporates the  $t_{LAD}$  parameter into the signal path.
- (4) Measured with a 16-bit loadable, enabled, up/down counter programmed into each LAB.
- (5) The  $f_{MAX}$  values represent the highest frequency for pipelined data.
- (6) Operating conditions:  $V_{CCIO} = 2.5 \pm 0.2 V$  for commercial and industrial use.
- (7) The  $t_{LPA}$  parameter must be added to the  $t_{LAD}$ ,  $t_{LAC}$ ,  $t_{IC}$ ,  $t_{EN}$ ,  $t_{SEXP}$ ,  $t_{ACL}$ , and  $t_{CPPW}$  parameters for macrocells running in low-power mode.
- (8) MAX 7000AE timing values are preliminary.

## Power Consumption

Supply power (P) versus frequency ( $f_{MAX}$ , in MHz) for MAX 7000A devices is calculated with the following equation:

$$P = P_{INT} + P_{IO} = I_{CCINT} \times V_{CC} + P_{IO}$$

The  $P_{IO}$  value, which depends on the device output load characteristics and switching frequency, can be calculated using the guidelines given in [Application Note 74 \(Evaluating Power for Altera Devices\)](#).

The  $I_{CCINT}$  value depends on the switching frequency and the application logic. The  $I_{CCINT}$  value is calculated with the following equation:

$$I_{CCINT} = (A \times MC_{TON}) + [B \times (MC_{DEV} - MC_{TON})] + (C \times MC_{USED} \times f_{MAX} \times \text{tog}_{LC})$$

The parameters in this equation are:

$MC_{TON}$	=	Number of macrocells with the Turbo Bit™ option turned on, as reported in the MAX+PLUS II Report File (.rpt)
$MC_{DEV}$	=	Number of macrocells in the device
$MC_{USED}$	=	Total number of macrocells in the design, as reported in the Report File
$f_{MAX}$	=	Highest clock frequency to the device
$\text{tog}_{LC}$	=	Average percentage of logic cells toggling at each clock (typically 12.5%)
A, B, C	=	Constants, shown in <a href="#">Table 21</a>

**Table 21. MAX 7000A  $I_{CC}$  Equation Constants**

Device	A	B	C
EPM7032AE (1)	0.46	0.28	0.032
EPM7064AE (1)	0.46	0.28	0.032
EPM7128A (1)	0.46	0.28	0.032
EPM7128AE (1)	0.46	0.28	0.032
EPM7256A (1)	0.46	0.28	0.032
EPM7256AE (1)	0.46	0.28	0.032
EPM7512AE (1)	0.46	0.28	0.032

**Note:**

(1) Values for these devices are preliminary.

This calculation provides an  $I_{CC}$  estimate based on typical conditions using a pattern of a 16-bit, loadable, enabled, up/down counter in each LAB with no output load. Actual  $I_{CC}$  should be verified during operation because this measurement is sensitive to the actual pattern in the device and the environmental operating conditions.

Figure 13 shows the typical supply current versus frequency for MAX 7000A devices.

Figure 13.  $I_{CC}$  vs. Frequency for MAX 7000A Devices (Part 1 of 2)

EPM7032AE

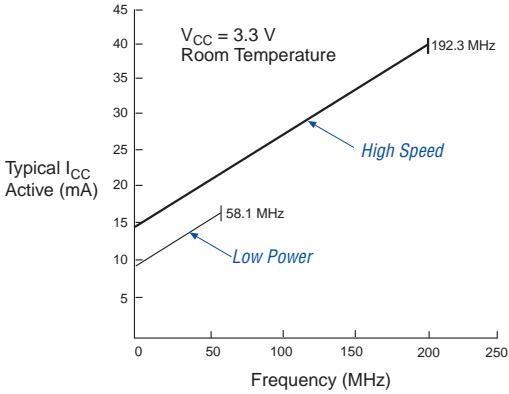

EPM7064AE

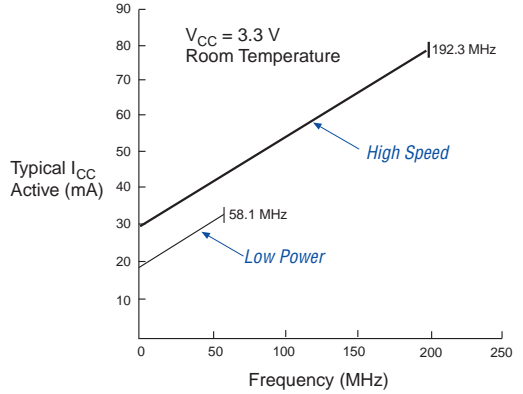

EPM7128A & EPM7128AE

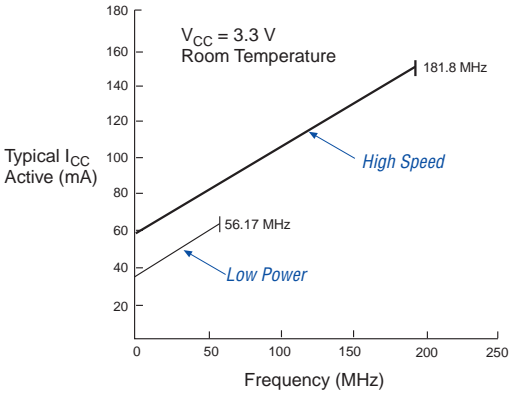
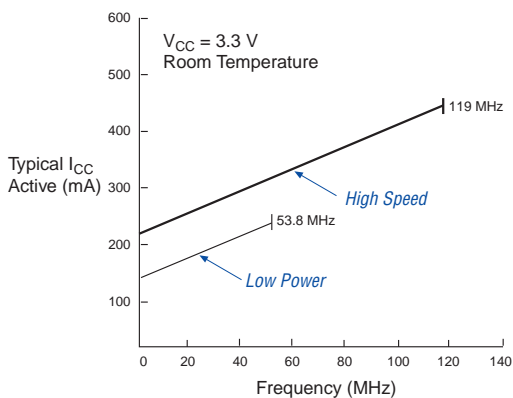
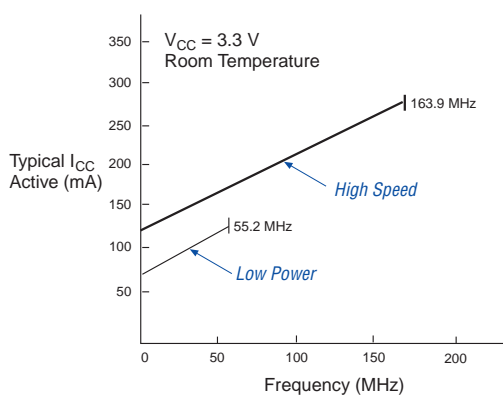



Figure 13.  $I_{CC}$  vs. Frequency for MAX 7000A Devices (Part 2 of 2)

EPM7256A & EPM7256AE

EPM7512AE



## Device Pin-Outs

Tables 22 through 32 show the pin names and numbers for the pins in MAX 7000A and MAX7000AE device packages.

Table 22. EPM7032AE Dedicated Pin-Outs

Dedicated Pin	44-Pin PLCC	44-Pin TQFP
INPUT/GCLK1	43	37
INPUT/GCLRn	1	39
INPUT/OE1	44	38
INPUT/OE2/GCLK2	2	40
TDI (1)	7	1
TMS (1)	13	7
TCK (1)	32	26
TDO (1)	38	32
GNDINT	22, 42	16, 36
GNDIO	10, 30	4, 24
VCCINT (3.3 V)	3, 23	17, 41
VCCIO (2.5 V or 3.3 V)	15, 35	9, 29
No Connect (N.C.)	—	—
Total User I/O Pins (2)	36	36

**Table 23. EPM7032AE I/O Pin-Outs**

LAB	MC	44-Pin PLCC	44-Pin TQFP	LAB	MC	44-Pin PLCC	44-Pin TQFP
A	1	4	42	B	17	41	35
	2	5	43		18	40	34
	3	6	44		19	39	33
	4	7 (1)	1 (1)		20	38 (1)	32 (1)
	5	8	2		21	37	31
	6	9	3		22	36	30
	7	11	5		23	34	28
	8	12	6		24	33	27
	9	13 (1)	7 (1)		25	32 (1)	26 (1)
	10	14	8		26	31	25
	11	16	10		27	29	23
	12	17	11		28	28	22
	13	18	12		29	27	21
	14	19	13		30	26	20
	15	20	14		31	25	19
	16	21	15		32	24	18

**Table 24. EPM7064AE Dedicated Pin-Outs**

Dedicated Pin	44-Pin PLCC	44-Pin TQFP	100-Pin TQFP	100-Pin FineLine BGA
INPUT/GCLK1	43	37	87	A6
INPUT/GCLRn	1	39	89	B5
INPUT/OE1	44	38	88	B6
INPUT/OE2/GCLK2	2	40	90	A5
TDI (1)	7	1	4	A1
TMS (1)	13	7	15	F3
TCK (1)	32	26	62	F8
TDO (1)	38	32	73	A10
GNDINT	22, 42	16, 36	38, 86	C3, D6, D7, E5, F6, G4, G5, H8
GNDIO	10, 30	4, 24	11, 26, 43, 59, 74, 95	–
VCCIINT (3.3 V Only)	3, 23	17, 41	39, 91	D5, G6
VCCIO (2.5 V or 3.3 V)	15, 35	9, 29	3, 18, 34, 51, 66, 82	C8, D4, E6, F5, G7, H3
No Connect (N.C.)	–	–	1, 2, 5, 7, 22, 24, 27, 28, 49, 50, 53, 55, 70, 72, 77, 78	B1, B10, C1, C9, C10, D8, E3, E4, H1, H9, H10, J1, J2, J10, K1, K9
Total User I/O Pins (2)	36	36	68	68

**Table 25. EPM7064AE I/O Pin-Outs (44-Pin PLCC & 44-Pin TQFP Packages)**

LAB	MC	44-Pin PLCC	44-Pin TQFP	LAB	MC	44-Pin PLCC	44-Pin TQFP
A	1	12	6	C	33	24	18
	2	–	–		34	–	–
	3	11	5		35	25	19
	4	9	3		36	26	20
	5	8	2		37	27	21
	6	–	–		38	–	–
	7	–	–		39	–	–
	8	7 (1)	1 (1)		40	28	22
	9	–	–		41	29	23
	10	–	–		42	–	–
	11	6	44		43	–	–
	12	–	–		44	–	–
	13	–	–		45	–	–
	14	5	43		46	31	25
	15	–	–		47	–	–
	16	4	42		48	32 (1)	26 (1)
B	17	21	15	D	49	33	27
	18	–	–		50	–	–
	19	20	14		51	34	28
	20	19	13		52	36	30
	21	18	12		53	37	31
	22	–	–		54	–	–
	23	–	–		55	–	–
	24	17	11		56	38 (1)	32 (1)
	25	16	10		57	39	33
	26	–	–		58	–	–
	27	–	–		59	–	–
	28	–	–		60	–	–
	29	–	–		61	–	–
	30	14	8		62	40	34
	31	–	–		63	–	–
	32	13 (1)	7 (1)		64	41	35

**Table 26. EPM7064AE I/O Pin-Outs (100-Pin TQFP & 100-Pin FineLine BGA Packages)**

LAB	MC	100-Pin TQFP	100-Pin FineLine BGA	LAB	MC	100-Pin TQFP	100-Pin FineLine BGA
A	1	14	F4	C	33	40	K6
	2	13	E2		34	41	J6
	3	12	E1		35	42	H6
	4	10	D2		36	44	K7
	5	9	D1		37	45	J7
	6	8	D3		38	46	H7
	7	6	C2		39	47	J8
	8	4 (1)	A1 (1)		40	48	K8
	9	100	B2		41	52	K10
	10	99	A2		42	54	J9
	11	98	A3		43	56	G9
	12	97	B3		44	57	G10
	13	96	A4		45	58	G8
	14	94	B4		46	60	F9
	15	93	C4		47	61	F10
	16	92	C5		48	62 (1)	F8 (1)
B	17	37	K5	D	49	63	F7
	18	36	J5		50	64	E9
	19	35	H5		51	65	E10
	20	33	K4		52	67	E8
	21	32	J4		53	68	E7
	22	31	H4		54	69	D9
	23	30	J3		55	71	D10
	24	29	K3		56	73 (1)	A10 (1)
	25	25	K2		57	75	B9
	26	23	H2		48	76	A9
	27	21	G2		59	79	A8
	28	20	G1		60	80	B8
	29	19	G3		61	81	A7
	30	17	F2		62	83	B7
	31	16	F1		63	84	C7
	32	15 (1)	F3 (1)		64	85	C6

**Notes to tables:**

- (1) This pin may function as either a JTAG port or a user I/O pin. If the device is configured to use the JTAG ports for in-system programming, this pin is not available as a user I/O pin.
- (2) The user I/O pin count includes dedicated input pins and all I/O pins.

**Table 27. EPM7128A & EPM7128AE Dedicated Pin-Outs**

Dedicated Pin	84-Pin PLCC	100-Pin TQFP	100-Pin FineLine BGA	144-Pin TQFP	256-Pin FineLine BGA
INPUT/GCLK1	83	87	A6	125	D9
INPUT/GCLRn	1	89	B5	127	E8
INPUT/OE1	84	88	B6	126	E9
INPUT/OE2/GCLK2	2	90	A5	128	D8
TDI (1)	14	4	A1	4	D4
TMS (1)	23	15	F3	20	J6
TCK (1)	62	62	F8	89	J11
TDO (1)	71	73	A10	104	D13
GNDINT	42, 82	38, 86	D6, G5	52, 57, 124, 129	A8, C9, G9, K8, P9
GNDIO	7, 19, 32, 47, 59, 72	11, 26, 43, 59, 74, 95	C3, D7, E5, F6, G4, H8	3, 13, 17, 33, 59, 64, 85, 105, 135	A3, B10, C2, D14, F6, G10, H8, J9, K7, L11, M3, P6, P10, R2, R3, T1, T15
VCCINT (3.3 V only)	3, 43	39, 91	D5, G6	51, 58, 123, 130	B9, C8, G8, K9, P8
VCCIO (2.5 V or 3.3 V)	13, 26, 38, 53, 66, 78	3, 18, 34, 51, 66, 82	C8, D4, E6, F5, G7, H3	24, 50, 73, 76, 95, 115, 144	B3, B5, C14, E15, F11, G3, G7, G15, H9, J8, K10, L3, L6, M15, P14, T2, T3
No Connect (N.C.)	—	—	—	1, 2, 12, 19, 34, 35, 36, 43, 46, 47, 48, 49, 66, 75, 90, 103, 108, 120, 121, 122	A1, A2, A4, A5, A6, A7, A9, A10, A11, A12, A13, A14, A15, A16, B1, B2, B4, B6, B7, B8, B11, B12, B13, B14, B 15, B16, C1, C3, C4, C6, C11, C13, C15, C16, D1, D2, D3, D15, D16, E1, E2, E3, E14, E16, F1, F2, F15, F16, G1, G2, G14, G16, H1, H2, H15, H16, J1, J2, J15, J16, K1, K2, K3, K14, K15, K16, L1, L2, L15, L16, M1, M14, M16, N1, N2, N3, N14, N15, N16, P1, P2, P3, P4, P12, P13, P15, P16, R1, R4, R5, R6, R7, R8, R9, R11, R12, R13, R14, R15, R16, T4, T5, T6, T7, T8, T9, T10, T11, T12, T13, T14, T16
Total User I/O Pins (2)	68	84	84	100	100

**Table 28. EPM7128A & EPM7128AE I/O Pin-Outs (Part 1 of 2)**

LAB	MC	84-Pin PLCC	100- Pin TQFP	100-Pin FineLine BGA	144-Pin TQFP	256-Pin FineLine BGA	LAB	MC	84-Pin PLCC	100- Pin TQFP	100-Pin FineLine BGA	144- Pin TQFP	256-Pin FineLine BGA	
A	1	–	2	C1	143	F4	C	33	–	25	K1	32	N4	
	2	–	–	–	–	–		34	–	–	–	–	–	–
	3	12	1	B1	142	E4		35	31	24	J1	31	M4	
	4	–	–	–	141	C5		36	–	–	–	30	M2	
	5	11	100	B2	140	E5		37	30	23	H1	29	L4	
	6	10	99	A2	139	D5		38	29	22	H2	28	L5	
	7	–	–	–	–	–		39	–	–	–	–	–	–
	8	9	98	A3	138	D6		40	28	21	G2	27	K5	
	9	–	97	B3	137	E6		41	–	20	G1	26	K4	
	10	–	–	–	–	–		42	–	–	–	–	–	–
	11	8	96	A4	136	D7		43	27	19	G3	25	K6	
	12	–	–	–	134	C7		44	–	–	–	23	J3	
	13	6	94	B4	133	E7		45	25	17	F2	22	J5	
	14	5	93	C4	132	F7		46	24	16	F1	21	J4	
	15	–	–	–	–	–		47	–	–	–	–	–	–
	16	4	92	C5	131	F8		48	23 (1)	15 (1)	F3 (1)	20 (1)	J6 (1)	
B	17	22	14	F4	18	J7	D	49	41	37	K5	56	N8	
	18	–	–	–	–	–		50	–	–	–	–	–	
	19	21	13	E2	16	H5		51	40	36	J5	55	M8	
	20	–	–	–	15	H3		52	–	–	–	54	P7	
	21	20	12	E1	14	H4		53	39	35	H5	53	L8	
	22	–	10	E3	11	H6		54	–	33	K4	45	N7	
	23	–	–	–	–	–		55	–	–	–	–	–	
	24	18	9	E4	10	H7		56	37	32	J4	44	M7	
	25	17	8	D2	9	G5		57	36	31	H4	42	L7	
	26	–	–	–	–	–		58	–	–	–	–	–	
	27	16	7	D1	8	G4		59	35	30	J3	41	M6	
	28	–	–	–	7	F3		60	–	–	–	40	P5	
	29	15	6	D3	6	G6		61	34	29	K3	39	N6	
	30	–	5	C2	5	F5		62	–	28	J2	38	M5	
	31	–	–	–	–	–		63	–	–	–	–	–	
	32	14 (1)	4 (1)	A1 (1)	4 (1)	D4 (1)		64	33	27	K2	37	N5	

Table 28. EPM7128A &amp; EPM7128AE I/O Pin-Outs (Part 2 of 2)

LAB	MC	84-Pin PLCC	100- Pin TQFP	100-Pin FineLine BGA	144-Pin TQFP	256-Pin FineLine BGA	LAB	MC	84-Pin PLCC	100- Pin TQFP	100-Pin FineLine BGA	144- Pin TQFP	256-Pin FineLine BGA	
E	65	44	40	K6	60	N9	G	97	63	63	F7	91	J10	
	66	–	–	–	–	–		98	–	–	–	–	–	–
	67	45	41	J6	61	M9		99	64	64	E9	92	H12	
	68	–	–	–	62	R10		100	–	–	–	93	H14	
	69	46	42	H6	63	L9		101	65	65	E10	94	H13	
	70	–	44	K7	65	N10		102	–	67	E8	96	H11	
	71	–	–	–	–	–		103	–	–	–	–	–	–
	72	48	45	J7	67	M10		104	67	68	E7	97	H10	
	73	49	46	H7	68	L10		105	68	69	D9	98	G12	
	74	–	–	–	–	–		106	–	–	–	–	–	–
	75	50	47	J8	69	M11		107	69	70	D10	99	G13	
	76	–	–	–	70	P11		108	–	–	–	100	F14	
	77	51	48	K8	71	N11		109	70	71	D8	101	G11	
	78	–	49	K9	72	N12		110	–	72	C9	102	F12	
	79	–	–	–	–	–		111	–	–	–	–	–	–
	80	52	50	K10	74	N13		112	71 (1)	73 (1)	A10 (1)	104 (1)	D13 (1)	
F	81	–	52	J10	77	M13	H	113	–	75	C10	106	F13	
	82	–	–	–	–	–		114	–	–	–	–	–	–
	83	54	53	H10	78	L13		115	73	76	B10	107	E13	
	84	–	–	–	79	L14		116	–	–	–	109	C12	
	85	55	54	H9	80	L12		117	74	77	B9	110	E12	
	86	56	55	J9	81	M12		118	75	78	A9	111	D12	
	87	–	–	–	–	–		119	–	–	–	–	–	–
	88	57	56	G9	82	K12		120	76	79	A8	112	D11	
	89	–	57	G10	83	K13		121	–	80	B8	113	E11	
	90	–	–	–	–	–		122	–	–	–	–	–	–
	91	58	58	G8	84	K11		123	77	81	A7	114	D10	
	92	–	–	–	86	J14		124	–	–	–	116	C10	
	93	60	60	F9	87	J12		125	79	83	B7	117	E10	
	94	61	61	F10	88	J13		126	80	84	C7	118	F10	
	95	–	–	–	–	–		127	–	–	–	–	–	–
	96	62 (1)	62 (1)	F8 (1)	89 (1)	J11 (1)		128	81	85	C6	119	F9	

**Notes to tables:**

- (1) This pin can function as either a JTAG port or a user I/O pin. If the device is configured to use the JTAG ports for BST or in-system programming, this pin is not available as a user I/O pin.
- (2) The user I/O pin count includes dedicated input pins and all I/O pins.



**Table 29. EPM7256A & EPM7256AE Dedicated Pin-Outs**

Dedicated Pin	100-Pin TQFP	100-Pin FineLine BGA	144-Pin TQFP	208-Pin PQFP	256-Pin FineLine BGA
INPUT/GCLK1	87	A6	125	184	D9
INPUT/GCLRn	89	B5	127	182	E8
INPUT/OE1	88	B6	126	183	E9
INPUT/OE2/GCLK2	90	A5	128	181	D8
TDI (1)	4	A1	4	176	D4
TMS (1)	15	F3	20	127	J6
TCK (1)	62	F8	89	30	J11
TDO (1)	73	A10	104	189	D13
GNDINT	38, 86	D6, G5	52, 57, 124, 129	75, 82, 180, 185	A8, C9, G9, K8, P9
GNDIO (2)	11, 26, 43, 59, 74, 95	C3, D7, E5, F6, G4, H8	3, 13, 17, 33, 59, 64, 85, 105, 135	14, 32, 50, 72, 94, 116, 134, 152, 174, 200	A3, B10, C2, D14, F6, G10, H8, J9, K7, L11, M3, P6, P10, R2, R3, T1, T15
VCCINT (3.3 V Only)	39, 91	D5, G6	51, 58, 123, 130	74, 83, 179, 186	B9, C8, G8, K9, P8
VCCIO (2.5 V or 3.3 V) (2)	3, 18, 34, 51, 66, 82	C8, D4, E6, F5, G7, H3	24, 50, 73, 76, 95, 115, 144	5, 23, 41, 63, 85, 107, 125, 143, 165, 191	B3, B5, C14, E15, F11, G3, G7, G15, H9, J8, K10, L3, L6, M15, P14, T2, T3
No Connect (N.C.)	—	—	—	1, 2, 51, 52, 53, 54, 103, 104, 105, 106, 155, 156, 157, 158, 207, 208	A1, A2, A6, A12, A13, A14, A15, A16, B1, B2, B15, B16, C1, C15, C16, D1, D3, D15, D16, G1, G16, H15, H16, J1, K1, L1, L2, M1, M16, N1, N2, N14, N15, N16, P1, P2, P15, P16, R1, R14, R15, R16, T7, T8, T10, T11, T14, T16
Total User I/O Pins (3)	84	84	120	164	164

**Table 30. EPM7256A & EPM7256AE I/O Pin-Outs (Part 1 of 4)**

LAB	MC	100-Pin TQFP	100-Pin FineLine BGA	144-Pin TQFP	208-Pin PQFP	256-Pin FineLine BGA	LAB	MC	100-Pin TQFP	100-Pin FineLine BGA	144-Pin TQFP	208-Pin PQFP	256-Pin FineLine BGA	
A	1	–	C1	–	153	C3	C	33	–	–	36	108	N4	
	2	–	–	–	–	–		34	–	–	–	–	–	–
	3	–	–	2	154	C4		35	–	–	35	109	P3	–
	4	–	–	–	–	–		36	–	–	–	–	–	–
	5	–	B1	1	159	E5		37	–	–	34	110	N3	–
	6	–	–	143	160	D5		38	–	–	–	111	M4	–
	7	–	–	–	–	–		39	–	–	–	–	–	–
	8	2	–	–	161	C5		40	25	K1	32	112	M2	–
	9	1	–	–	162	B4		41	24	J1	31	113	L4	–
	10	–	–	–	–	–		42	–	–	–	–	–	–
	11	100	B2	142	163	A4		43	23	H1	30	114	L5	–
	12	–	–	–	–	–		44	–	–	–	–	–	–
	13	–	–	141	164	A5		45	22	H2	29	115	K6	–
	14	99	A2	140	166	D6		46	–	–	–	117	K5	–
	15	–	–	–	–	–		47	–	–	–	–	–	–
	16	98	A3	139	167	C6		48	21	G2	28	118	K4	–
B	17	–	–	–	141	F5	D	49	31	H4	44	92	N6	
	18	–	–	–	–	–		50	–	–	–	–	–	
	19	–	–	10	142	F2		51	30	J3	43	93	T5	
	20	–	–	–	–	–		52	–	–	–	–	–	
	21	–	–	9	144	E1		53	29	K3	42	95	M6	
	22	–	–	–	145	F4		54	28	J2	41	96	R5	
	23	–	–	–	–	–		55	–	–	–	–	–	
	24	8	D2	8	146	F3		56	–	–	40	97	M5	
	25	7	D1	7	147	E2		57	–	–	–	98	P5	
	26	–	–	–	–	–		58	–	–	–	–	–	
	27	6	D3	6	148	D2		59	–	–	39	99	N5	
	28	–	–	–	–	–		60	–	–	–	–	–	
	29	5	C2	5	149	E3		61	–	–	38	100	T4	
	30	–	–	–	150	E4		62	–	–	–	101	R4	
	31	–	–	–	–	–		63	–	–	–	–	–	
	32	4 (1)	A1 (1)	4 (1)	151	D4 (1)		64	27	K2	37	102	P4	

Table 30. EPM7256A &amp; EPM7256AE I/O Pin-Outs (Part 2 of 4)

LAB	MC	100-Pin TQFP	100-Pin FineLine BGA	144-Pin TQFP	208-Pin PQFP	256-Pin FineLine BGA	LAB	MC	100-Pin TQFP	100-Pin FineLine BGA	144-Pin TQFP	208-Pin PQFP	256-Pin FineLine BGA	
E	65	–	–	–	168	B6	G	97	–	–	–	119	K3	
	66	–	–	–	–	–		98	–	–	–	–	–	–
	67	–	–	–	169	E6		99	–	–	27	120	K2	–
	68	–	–	–	–	–		100	–	–	–	–	–	–
	69	–	–	138	170	F7		101	–	–	26	121	J7	–
	70	–	–	–	171	E7		102	–	–	–	122	H7	–
	71	–	–	–	–	–		103	–	–	–	–	–	–
	72	97	B3	137	172	D7		104	20	G1	25	123	J5	–
	73	96	A4	136	173	C7		105	19	G3	23	124	J2	–
	74	–	–	–	–	–		106	–	–	–	–	–	–
	75	94	B4	134	175	B7		107	17	F2	22	126	J3	–
	76	–	–	–	–	–		108	–	–	–	–	–	–
	77	93	C4	133	176 (1)	A7		109	16	F1	21	127 (1)	J4	–
	78	–	–	132	177	F8		110	–	–	–	128	H6	–
	79	–	–	–	–	–		111	–	–	–	–	–	–
	80	92	C5	131	178	B8		112	15 (1)	F3 (1)	20 (1)	129	J6 (1)	–
F	81	–	–	–	130	H5	H	113	37	K5	–	79	M8	
	82	–	–	–	–	–		114	–	–	–	–	–	
	83	–	–	19	131	H1		115	36	J5	54	80	N8	–
	84	–	–	–	–	–		116	–	–	–	–	–	–
	85	–	–	18	132	H2		117	–	–	53	81	L8	–
	86	–	–	–	133	H3		118	35	H5	–	84	R7	–
	87	–	–	–	–	–		119	–	–	–	–	–	–
	88	14	F4	16	135	H4		120	–	–	49	86	P7	–
	89	13	E2	15	136	G6		121	–	–	48	87	N7	–
	90	–	–	–	–	–		122	–	–	–	–	–	–
	91	12	E1	14	137	G5		123	–	–	47	88	M7	–
	92	–	–	–	–	–		124	–	–	–	–	–	–
	93	10	E3	12	138	G2		125	33	K4	46	89	L7	–
	94	–	–	–	139	G4		126	–	–	–	90	T6	–
	95	–	–	–	–	–		127	–	–	–	–	–	–
	96	9	E4	11	140	F1		128	32	J4	45	91	R6	–

Table 30. EPM7256A &amp; EPM7256AE I/O Pin-Outs (Part 3 of 4)

LAB	MC	100-Pin TQFP	100-Pin FineLine BGA	144-Pin TQFP	208-Pin PQFP	256-Pin FineLine BGA	LAB	MC	100-Pin TQFP	100-Pin FineLine BGA	144-Pin TQFP	208-Pin PQFP	256-Pin FineLine BGA	
I	129	80	B8	114	197	C11	K	161	–	–	–	38	K11	
	130	–	–	–	–	–		162	–	–	–	–	–	–
	131	81	A7	116	196	B11		163	57	G10	82	37	K12	
	132	–	–	–	–	–		164	–	–	–	–	–	–
	133	–	–	117	195	A11		165	–	–	83	36	K14	
	134	–	–	–	194	F10		166	–	–	–	35	K13	
	135	–	–	–	–	–		167	–	–	–	–	–	–
	136	–	–	118	193	E10		168	58	G8	84	34	K15	
	137	–	–	119	192	A10		169	–	–	86	33	K16	
	138	–	–	–	–	–		170	–	–	–	–	–	–
	139	83	B7	120	190	C10		171	60	F9	87	31	J13	
	140	–	–	–	–	–		172	–	–	–	–	–	–
	141	84	C7	121	189 (1)	D10		173	61	F10	88	30 (1)	J14	
	142	–	–	–	188	F9		174	–	–	–	29	J12	
	143	–	–	–	–	–		175	–	–	–	–	–	–
	144	85	C6	122	187	A9		176	62 (1)	F8 (1)	89 (1)	28	J11 (1)	
J	145	63	F7	–	27	J15	L	177	–	–	–	78	R8	
	146	–	–	–	–	–		178	–	–	–	–	–	
	147	64	E9	90	26	J16		179	–	–	55	77	T9	
	148	–	–	–	–	–		180	–	–	–	–	–	
	149	65	E10	91	25	J10		181	–	–	56	76	R9	
	150	–	–	–	24	H14		182	–	–	–	73	N9	
	151	–	–	–	–	–		183	–	–	–	–	–	
	152	–	–	92	22	H13		184	40	K6	60	71	M9	
	153	–	–	93	21	H12		185	41	J6	61	70	L9	
	154	–	–	–	–	–		186	–	–	–	–	–	
	155	67	E8	94	20	H11		187	42	H6	62	69	R10	
	156	–	–	–	–	–		188	–	–	–	–	–	
	157	–	–	96	19	H10		189	44	K7	63	68	N10	
	158	–	–	–	18	G11		190	–	–	–	67	M10	
	159	–	–	–	–	–		191	–	–	–	–	–	
	160	68	E7	97	17	G14		192	45	J7	65	66	L10	

**Table 30. EPM7256A & EPM7256AE I/O Pin-Outs (Part 4 of 4)**

LAB	MC	100-Pin TQFP	100-Pin FineLine BGA	144-Pin TQFP	208-Pin PQFP	256-Pin FineLine BGA	LAB	MC	100-Pin TQFP	100-Pin FineLine BGA	144-Pin TQFP	208-Pin PQFP	256-Pin FineLine BGA	
M	193	–	–	106	4	B14	O	225	–	–	–	49	R13	
	194	–	–	–	–	–		226	–	–	–	–	–	–
	195	75	C10	107	3	C13		227	–	–	74	48	P13	–
	196	–	–	–	–	–		228	–	–	–	–	–	–
	197	–	–	108	206	B13		229	–	–	75	47	N13	–
	198	–	–	–	205	F12		230	–	–	–	46	M14	–
	199	–	–	–	–	–		231	–	–	–	–	–	–
	200	–	–	109	204	E12		232	52	J10	77	45	M13	–
	201	76	B10	110	203	D12		233	53	H10	78	44	L13	–
	202	–	–	–	–	–		234	–	–	–	–	–	–
	203	77	B9	111	202	C12		235	54	H9	79	43	L14	–
	204	–	–	–	–	–		236	–	–	–	–	–	–
	205	–	–	–	201	B12		237	55	J9	80	42	L12	–
	206	78	A9	112	199	E11		238	–	–	–	40	L15	–
	207	–	–	–	–	–		239	–	–	–	–	–	–
	208	79	A8	113	198	D11		240	56	G9	81	39	L16	–
N	209	–	–	–	16	G13	P	241	46	H7	66	65	R11	
	210	–	–	–	–	–		242	–	–	–	–	–	
	211	69	D9	98	15	G12		243	47	J8	67	64	P11	
	212	–	–	–	–	–		244	–	–	–	–	–	
	213	–	–	99	13	F16		245	48	K8	68	62	N11	
	214	–	–	–	12	F15		246	49	K9	69	61	M11	
	215	–	–	–	–	–		247	–	–	–	–	–	
	216	70	D10	100	11	F13		248	–	–	–	60	T12	
	217	–	–	101	10	F14		249	–	–	70	59	R12	
	218	–	–	–	–	–		250	–	–	–	–	–	
	219	71	D8	102	9	E16		251	–	–	–	58	M12	
	220	–	–	–	–	–		252	–	–	–	–	–	
	221	72	C9	103	8	E14		253	–	–	71	57	P12	
	222	–	–	–	7	E13		254	–	–	–	56	N12	
	223	–	–	–	–	–		255	–	–	–	–	–	
	224	73 (1)	A10 (1)	104 (1)	6	D13 (1)		256	50	K10	72	55	T13	

**Notes to tables:**

- (1) This pin can function as either a JTAG pin or a user I/O pin. If the device is programmed to use the JTAG ports for BST or in-system programming, this pin is not available as a user I/O pin.
- (2) EPM7512AE devices in the 208-pin PQFP package support vertical migration from EPM7256E, EPM7256S, and EPM7256A devices. EPM7512AE devices contain additional I/O pins which are no connects on the EPM7256E, EPM7256S, and EPM7256A devices. To support these additional I/O pins, EPM7512AE devices have two additional VCCIO (pins 105 and 207) and GNDIO (pins 51 and 158) pins that are no-connect pins on the EPM7256E, EPM7256S, and EPM7256A devices. To achieve vertical migration between the EPM7256A and EPM7512AE devices, the no-connect pins 105 and 207 may be tied to VCCIO and pins 51 and 158 may be tied to GNDIO on the EPM7256A devices. On the EPM7256E and EPM7256S devices, these no-connect pins must not be tied to VCCIO or GNDIO.
- (3) The user I/O pin count includes dedicated input pins and all I/O pins.

**Table 31. EPM7512AE Dedicated Pin-Outs**

Dedicated Pin	144-Pin TQFP	208-Pin PQFP (1)	256-Pin BGA	256-Pin FineLine BGA
INPUT/GCLK1	125	184	L1	D9
INPUT/GCLRn	127	182	K2	E8
INPUT/OE1	126	183	K1	E9
INPUT/OE2/GCLK2	128	181	K3	D8
TDI (2)	4	176	A2	D4
TMS (2)	20	127	B12	J6
TCK (2)	89	30	V12	J11
TDO (2)	104	189	Y2	D13
GNDINT	52, 57, 124, 129	75, 82, 180, 185	J20, K4, K18, L2, L17	A8, C9, G9, K8, P9
GNDIO	3, 13, 17, 33, 59, 64, 85, 105, 135	14, 32, 50, 51, 72, 94, 116, 134, 152, 158, 174, 200	A1, B2, B19, B20, C3, C18, D4, D17, U4, U17, V3, V18, V19, W2, W19, Y1, Y20	A3, B10, C2, D14, F6, G10, H8, J9, K7, L11, M3, P6, P10, R2, R3, T1, T15
VCCINT	51, 58, 123, 130	74, 83, 179, 186	J1, J19, L4, M19, M20	B9, C8, G8, K9, P8
VCCIO	24, 50, 73, 76, 95, 115, 144	5, 23, 41, 63, 85, 105, 107, 125, 143, 165, 191, 207	C4, C17, D3, D5, D16, D18, E4, E17, T4, T17, U3, U5, U16, U18, V2, V4, V17	B3, B5, C14, E15, F11, G3, G7, G15, H9, J8, K10, L3, L6, M15, P14, T2, T3
No Connect (N.C.)	–	–	–	–
Total User I/O Pins (3)	120	176	212	212

**Table 32. EPM7512AE I/O Pin-Outs (Part 1 of 8)**

LAB	MC	144-Pin TQFP	208-Pin PQFP (1)	256-Pin BGA	256-Pin FineLine BGA	LAB	MC	144-Pin TQFP	208-Pin PQFP (1)	256-Pin BGA	256-Pin FineLine BGA
A	1	134	173	H3	D7	C	33	142	163	F4	E4
	2	–	–	–	–		34	–	–	–	–
	3	–	–	–	–		35	–	–	–	–
	4	–	–	–	–		36	–	–	–	–
	5	–	–	H2	C7		37	141	164	E3	C5
	6	–	–	–	–		38	–	–	–	–
	7	–	–	–	–		39	–	–	–	–
	8	–	–	–	–		40	–	–	–	–
	9	–	175	H1	B7		41	140	166	E2	A5
	10	–	–	–	–		42	–	–	–	–
	11	133	176 (2)	J4	A7		43	–	167	F3	D5
	12	–	–	–	–		44	–	–	–	–
	13	–	–	–	–		45	–	–	–	–
	14	132	177	J3	F8		46	139	168	E1	E5
	15	–	–	–	–		47	–	–	–	–
	16	131	178	J2	B8		48	–	–	F2	E6
B	17	–	169	G4	D6	D	49	2	–	B3	B2
	18	–	–	–	–		50	–	–	–	–
	19	–	–	–	–		51	–	–	–	–
	20	–	–	–	–		52	–	–	–	–
	21	138	170	F1	C6		53	1	–	C2	A2
	22	–	–	–	–		54	–	–	–	–
	23	–	–	–	–		55	–	–	–	–
	24	–	–	–	–		56	–	–	–	–
	25	137	171	G3	B6		57	–	159	B1	B4
	26	–	–	–	–		58	–	–	–	–
	27	136	172	G2	A6		59	–	160	C1	A4
	28	–	–	–	–		60	–	–	–	–
	29	–	–	–	–		61	–	–	–	–
	30	–	–	G1	F7		62	–	161	D2	C4
	31	–	–	–	–		63	–	–	–	–
	32	–	–	H4	E7		64	143	162	D1	C3

Table 32. EPM7512AE I/O Pin-Outs (Part 2 of 8)

LAB	MC	144-Pin TQFP	208-Pin PQFP (1)	256-Pin BGA	256-Pin FineLine BGA	LAB	MC	144-Pin TQFP	208-Pin PQFP (1)	256-Pin BGA	256-Pin FineLine BGA
E	65	–	–	B5	E3	G	97	–	–	C9	H6
	66	–	–	–	–		98	–	–	–	–
	67	7	153	C5	C1		99	15	141	D9	G5
	68	–	–	–	–		100	–	–	–	–
	69	–	–	D6	B1		101	14	142	A8	G4
	70	–	–	–	–		102	–	–	–	–
	71	–	–	–	–		103	–	–	–	–
	72	–	–	–	–		104	–	–	–	–
	73	–	154	A4	A1		105	–	144	B8	G2
	74	–	–	–	–		106	–	–	–	–
	75	6	155	B4	D2		107	–	145	C8	G1
	76	–	–	–	–		108	–	–	–	–
	77	–	–	–	–		109	–	–	–	–
	78	5	156	A3	D3		110	12	146	D8	G6
	79	–	–	–	–		111	–	–	–	–
	80	4 (2)	157	A2 (2)	D4 (2)		112	–	–	A7	F5
F	81	–	147	B7	F2	H	113	19	135	A11	J1
	82	–	–	–	–		114	–	–	–	–
	83	–	148	C7	F3		115	–	136	A10	H7
	84	–	–	–	–		116	–	–	–	–
	85	11	149	A6	F1		117	18	137	B10	H5
	86	–	–	–	–		118	–	–	–	–
	87	–	–	–	–		119	–	–	–	–
	88	–	–	–	–		120	–	–	–	–
	89	–	–	D7	F4		121	–	–	D10	H2
	90	–	–	–	–		122	–	–	–	–
	91	10	150	B6	E1		123	–	138	C10	H3
	92	–	–	–	–		124	–	–	–	–
	93	–	–	–	–		125	–	–	–	–
	94	9	151	A5	D1		126	–	139	A9	H1
	95	–	–	–	–		127	–	–	–	–
	96	8	–	C6	E2		128	16	140	B9	H4



Table 32. EPM7512AE I/O Pin-Outs (Part 3 of 8)

LAB	MC	144-Pin TQFP	208-Pin PQFP (1)	256-Pin BGA	256-Pin FineLine BGA	LAB	MC	144-Pin TQFP	208-Pin PQFP (1)	256-Pin BGA	256-Pin FineLine BGA
I	129	–	–	D12	K1	K	161	29	115	B16	N4
	130	–	–	–	–		162	–	–	–	–
	131	–	129	C12	J7		163	–	117	C15	M2
	132	–	–	–	–		164	–	–	–	–
	133	20 (2)	130	B12 (2)	J6 (2)		165	–	118	A17	M1
	134	–	–	–	–		166	–	–	–	–
	135	–	–	–	–		167	–	–	–	–
	136	–	–	–	–		168	–	–	–	–
	137	–	131	A12	J5		169	28	119	B15	M4
	138	–	–	–	–		170	–	–	–	–
	139	–	–	D11	J4		171	–	–	D14	M5
	140	–	–	–	–		172	–	–	–	–
	141	–	–	–	–		173	–	–	–	–
	142	–	132	C11	J3		174	–	120	A16	L5
	143	–	–	–	–		175	–	–	–	–
144	–	133	B11	J2	176	27	121	A15	L4		
J	145	–	122	C14	L2	L	177	34	109	A20	R1
	146	–	–	–	–		178	–	–	–	–
	147	–	–	B14	L1		179	–	–	–	–
	148	–	–	–	–		180	–	–	–	–
	149	26	123	A14	K6		181	32	110	A19	P2
	150	–	–	–	–		182	–	–	–	–
	151	–	–	–	–		183	–	–	–	–
	152	–	–	–	–		184	–	–	–	–
	153	25	124	D13	K5		185	–	111	B17	N3
	154	–	–	–	–		186	–	–	–	–
	155	23	126	C13	K4		187	–	112	A18	N2
	156	–	–	–	–		188	–	–	–	–
	157	–	–	–	–		189	–	–	–	–
	158	22	127 (2)	B13	K3		190	31	113	D15	P1
	159	–	–	–	–		191	–	–	–	–
160	21	128	A13	K2	192	30	114	C16	N1		

Table 32. EPM7512AE I/O Pin-Outs (Part 4 of 8)

LAB	MC	144-Pin TQFP	208-Pin PQFP (1)	256-Pin BGA	256-Pin FineLine BGA	LAB	MC	144-Pin TQFP	208-Pin PQFP (1)	256-Pin BGA	256-Pin FineLine BGA
M	193	–	101	E18	P5	O	225	47	88	H19	R7
	194	–	–	–	–		226	–	–	–	–
	195	–	–	–	–		227	46	89	H18	P7
	196	–	–	–	–		228	–	–	–	–
	197	–	102	D20	N5		229	45	90	H17	T7
	198	–	–	–	–		230	–	–	–	–
	199	–	–	–	–		231	–	–	–	–
	200	–	–	–	–		232	–	–	–	–
	201	37	103	D19	T4		233	–	91	G20	L8
	202	–	–	–	–		234	–	–	–	–
	203	–	104	C20	R4		235	44	92	G19	N7
	204	–	–	–	–		236	–	–	–	–
	205	–	–	–	–		237	–	–	–	–
	206	36	106	C19	P4		238	–	–	G18	M7
	207	–	–	–	–		239	–	–	–	–
	208	35	108	B18	P3		240	43	93	F20	L7
N	209	42	95	G17	R6	P	241	54	79	K20	M9
	210	–	–	–	–		242	–	–	–	–
	211	–	–	–	–		243	–	–	–	–
	212	–	–	–	–		244	–	–	–	–
	213	41	96	F19	T6		245	–	80	K19	L9
	214	–	–	–	–		246	–	–	–	–
	215	–	–	–	–		247	–	–	–	–
	216	–	–	–	–		248	–	–	–	–
	217	40	97	E20	N6		249	53	81	K17	R8
	218	–	–	–	–		250	–	–	–	–
	219	39	98	F18	M6		251	–	84	J18	T8
	220	–	–	–	–		252	–	–	–	–
	221	–	–	–	–		253	–	–	–	–
	222	–	99	E19	R5		254	49	86	J17	N8
	223	–	–	–	–		255	–	–	–	–
	224	38	100	F17	T5		256	48	87	H20	M8

**Table 32. EPM7512AE I/O Pin-Outs (Part 5 of 8)**

LAB	MC	144-Pin TQFP	208-Pin PQFP (1)	256-Pin BGA	256-Pin FineLine BGA	LAB	MC	144-Pin TQFP	208-Pin PQFP (1)	256-Pin BGA	256-Pin FineLine BGA
Q	257	55	78	L20	N9	S	289	66	62	P17	K11
	258	–	–	–	–		290	–	–	–	–
	259	–	–	–	–		291	–	–	–	–
	260	–	–	–	–		292	–	–	–	–
	261	–	77	L19	T9		293	67	61	R19	M12
	262	–	–	–	–		294	–	–	–	–
	263	–	–	–	–		295	–	–	–	–
	264	–	–	–	–		296	–	–	–	–
	265	56	76	L18	R9		297	68	60	T20	N12
	266	–	–	–	–		298	–	–	–	–
	267	–	73	M18	L10		299	69	59	R18	T12
	268	–	–	–	–		300	–	–	–	–
	269	–	–	–	–		301	–	–	–	–
	270	60	71	M17	M10		302	–	58	T19	R12
	271	–	–	–	–		303	–	–	–	–
272	61	70	N20	N10	304	70	57	T18	T13		
R	273	62	69	N19	R10	T	305	–	56	R17	P12
	274	–	–	–	–		306	–	–	–	–
	275	63	68	N18	T10		307	–	–	–	–
	276	–	–	–	–		308	–	–	–	–
	277	–	67	N17	M11		309	–	55	U20	T14
	278	–	–	–	–		310	–	–	–	–
	279	–	–	–	–		311	–	–	–	–
	280	–	–	–	–		312	–	–	–	–
	281	–	66	P20	N11		313	71	54	U19	P13
	282	–	–	–	–		314	–	–	–	–
	283	65	65	P19	P11		315	72	53	V20	R13
	284	–	–	–	–		316	–	–	–	–
	285	–	–	–	–		317	–	–	–	–
	286	–	–	P18	R11		318	–	52	W20	R14
	287	–	–	–	–		319	–	–	–	–
	288	–	64	R20	T11		320	74	49	W18	R15

Table 32. EPM7512AE I/O Pin-Outs (Part 6 of 8)

LAB	MC	144-Pin TQFP	208-Pin PQFP (1)	256-Pin BGA	256-Pin FineLine BGA	LAB	MC	144-Pin TQFP	208-Pin PQFP (1)	256-Pin BGA	256-Pin FineLine BGA
U	321	75	48	Y19	P15	W	353	82	35	W14	L16
	322	–	–	–	–		354	–	–	–	–
	323	–	–	–	–		355	–	–	Y14	L13
	324	–	–	–	–		356	–	–	–	–
	325	–	47	Y18	N15		357	83	34	U13	L12
	326	–	–	–	–		358	–	–	–	–
	327	–	–	–	–		359	–	–	–	–
	328	–	–	–	–		360	–	–	–	–
	329	–	46	W17	T16		361	84	33	V13	K12
	330	–	–	–	–		362	–	–	–	–
	331	–	45	Y17	R16		363	86	31	W13	K14
	332	–	–	–	–		364	–	–	–	–
	333	–	–	–	–		365	–	–	–	–
	334	77	44	U15	P16		366	87	30 (2)	Y13	K15
	335	–	–	–	–		367	–	–	–	–
	336	78	43	V16	N14		368	88	29	U12	K16
V	337	79	42	W16	N16	X	369	89 (2)	–	V12 (2)	J11 (2)
	338	–	–	–	–		370	–	–	–	–
	339	80	40	V15	M14		371	–	28	W12	J12
	340	–	–	–	–		372	–	–	–	–
	341	–	39	Y16	N13		373	–	27	Y12	J13
	342	–	–	–	–		374	–	–	–	–
	343	–	–	–	–		375	–	–	–	–
	344	–	–	–	–		376	–	–	–	–
	345	81	38	W15	M16		377	–	26	V11	J14
	346	–	–	–	–		378	–	–	–	–
	347	–	–	U14	M13		379	–	–	U11	J15
	348	–	–	–	–		380	–	–	–	–
	349	–	–	–	–		381	–	–	–	–
	350	–	37	Y15	L14		382	–	25	W11	K13
	351	–	–	–	–		383	–	–	–	–
	352	–	36	V14	L15		384	90	24	Y11	J16

**Table 32. EPM7512AE I/O Pin-Outs (Part 7 of 8)**

LAB	MC	144-Pin TQFP	208-Pin PQFP (1)	256-Pin BGA	256-Pin FineLine BGA	LAB	MC	144-Pin TQFP	208-Pin PQFP (1)	256-Pin BGA	256-Pin FineLine BGA
Y	385	91	22	Y10	H10	AA	417	–	10	V7	F14
	386	–	–	–	–		418	–	–	–	–
	387	–	21	W10	H11		419	–	9	Y6	F15
	388	–	–	–	–		420	–	–	–	–
	389	92	20	V10	H12		421	98	8	U7	F16
	390	–	–	–	–		422	–	–	–	–
	391	–	–	–	–		423	–	–	–	–
	392	–	–	–	–		424	–	–	–	–
	393	–	–	U10	H15		425	–	–	W6	E12
	394	–	–	–	–		426	–	–	–	–
	395	–	19	Y9	H16		427	99	7	Y5	E13
	396	–	–	–	–		428	–	–	–	–
	397	–	–	–	–		429	–	–	–	–
	398	–	18	W9	H14		430	100	6	V6	E14
	399	–	–	–	–		431	–	–	–	–
	400	93	17	V9	H13		432	101	–	W5	E16
Z	401	–	–	U9	G12	BB	433	–	–	V5	D16
	402	–	–	–	–		434	–	–	–	–
	403	–	16	Y8	G13		435	102	4	U6	C16
	404	–	–	–	–		436	–	–	–	–
	405	94	15	W8	G14		437	–	–	Y4	B16
	406	–	–	–	–		438	–	–	–	–
	407	–	–	–	–		439	–	–	–	–
	408	–	–	–	–		440	–	–	–	–
	409	96	13	V8	G16		441	–	3	W4	A16
	410	–	–	–	–		442	–	–	–	–
	411	–	12	U8	G11		443	103	2	Y3	D15
	412	–	–	–	–		444	–	–	–	–
	413	–	–	–	–		445	–	–	–	–
	414	97	11	Y7	F12		446	104 (2)	1	Y2 (2)	D13 (2)
	415	–	–	–	–		447	–	–	–	–
	416	–	–	W7	F13		448	106	208	W3	C15

Table 32. EPM7512AE I/O Pin-Outs (Part 8 of 8)

LAB	MC	144-Pin TQFP	208-Pin PQFP (1)	256-Pin BGA	256-Pin FineLine BGA	LAB	MC	144-Pin TQFP	208-Pin PQFP (1)	256-Pin BGA	256-Pin FineLine BGA
CC	449	–	–	W1	B15	EE	481	–	196	P3	D11
	450	–	–	–	–		482	–	–	–	–
	451	–	–	–	–		483	–	–	–	–
	452	–	–	–	–		484	–	–	–	–
	453	107	–	V1	A15		485	113	195	P2	C11
	454	–	–	–	–		486	–	–	–	–
	455	–	–	–	–		487	–	–	–	–
	456	–	–	–	–		488	–	–	–	–
	457	108	206	U2	B14		489	114	194	P1	A11
	458	–	–	–	–		490	–	–	–	–
	459	–	205	U1	A14		491	116	193	N4	B11
	460	–	–	–	–		492	–	–	–	–
	461	–	–	–	–		493	–	–	–	–
	462	–	204	T3	B13		494	117	–	N3	F10
	463	–	–	–	–		495	–	–	–	–
	464	109	203	R4	A13		496	–	–	N2	E10
DD	465	–	202	T2	C13	FF	497	118	192	N1	D10
	466	–	–	–	–		498	–	–	–	–
	467	–	–	–	–		499	–	–	–	–
	468	–	–	–	–		500	–	–	–	–
	469	110	201	R3	D12		501	–	–	M4	C10
	470	–	–	–	–		502	–	–	–	–
	471	–	–	–	–		503	–	–	–	–
	472	–	–	–	–		504	–	–	–	–
	473	111	199	T1	C12		505	119	190	M3	A10
	474	–	–	–	–		506	–	–	–	–
	475	–	198	R2	B12		507	120	189 (2)	M2	J10
	476	–	–	–	–		508	–	–	–	–
	477	–	–	–	–		509	–	–	–	–
	478	112	197	P4	A12		510	121	188	M1	F9
	479	–	–	–	–		511	–	–	–	–
	480	–	–	R1	E11		512	122	187	L3	A9

**Notes to tables:**

- (1) The EPM7512AE device in the 208-pin PQFP package supports vertical migration from the EPM7256E, EPM7256S, and EPM7256A devices. The EPM7512AE device contains additional I/O pins which are no connects on the EPM7256E, EPM7256S, and EPM7256A devices. To support these additional I/O pins, the EPM7512AE device has two additional VCCIO (pins 105 and 207) and GNDIO (pins 51 and 158) pins that are no-connect pins on the EPM7256E, EPM7256S, and EPM7256A devices. To achieve vertical migration between the EPM7256A and EPM7512AE devices, the no-connect pins 105 and 207 may be tied to VCCIO and pins 51 and 158 may be tied to GNDIO on the EPM7256A devices. On the EPM7256E and EPM7256S devices, these no-connect pins must not be tied to VCCIO or GNDIO. EPM7512AE devices have identical pin-outs.
- (2) This pin may function as either a JTAG port or a user I/O pin. If the device is configured to use the JTAG ports for in-system programming, this pin is not available as a user I/O pin.
- (3) The user I/O pin count includes dedicated input pins and all I/O pins.

Figures 14 through 21 show the package pin-out diagrams for MAX 7000A devices.

**Figure 14. 44-Pin PLCC/TQFP Package Pin-Out Diagram**

Package outlines not drawn to scale.

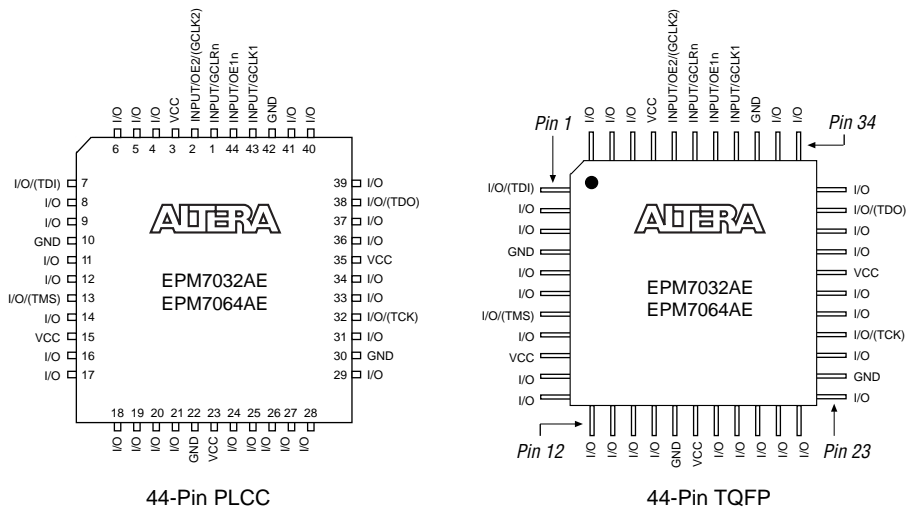

**Figure 15. 84-Pin PLCC Package Pin-Out Diagram**

Package outline not drawn to scale.

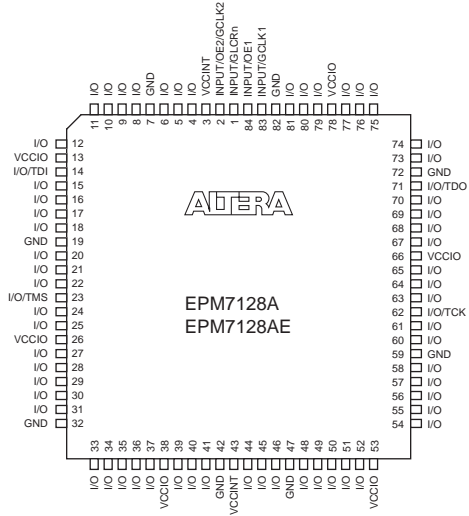

**Figure 16. 100-Pin TQFP Package Pin-Out Diagram**

Package outline not drawn to scale.

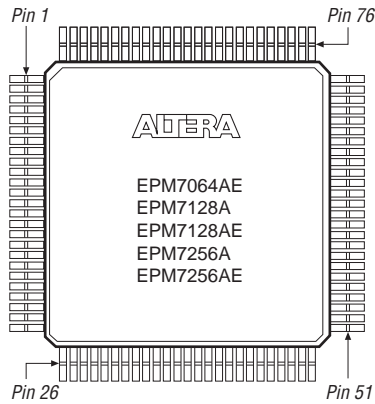



**Figure 17. 100-Pin FineLine BGA Package Pin-Out Diagram**

Package outline not drawn to scale.

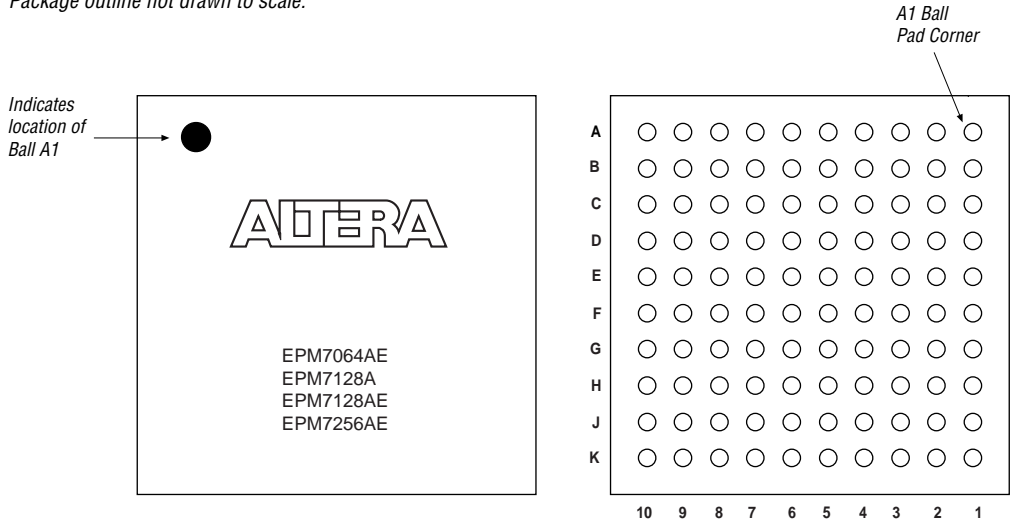

**Figure 18. 144-Pin TQFP Package Pin-Out Diagram**

Package outline not drawn to scale.

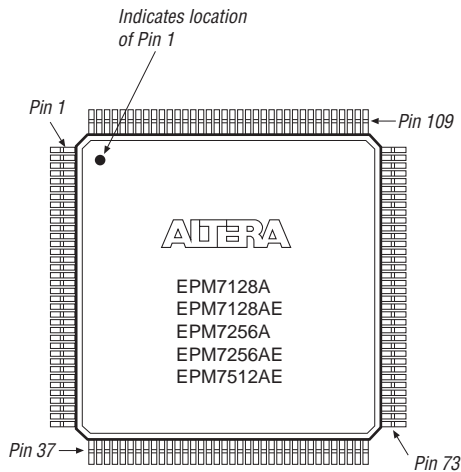

**Figure 19. 208-Pin PQFP Package Pin-Out Diagram**

Package outline not drawn to scale.

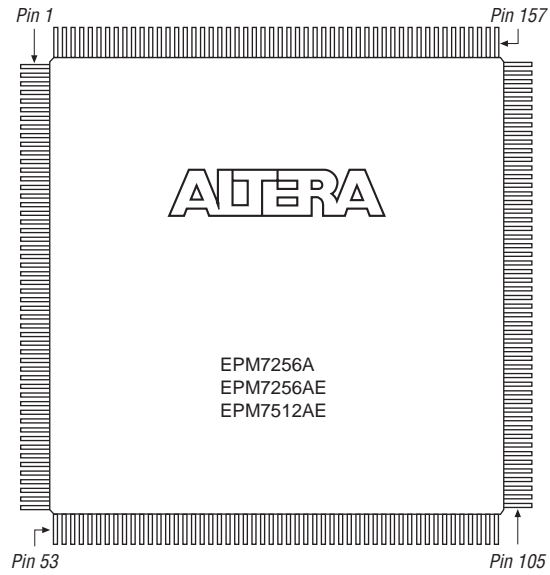

**Figure 20. 256-Pin BGA Package Pin-Out Diagram**

*Package outline not drawn to scale.*

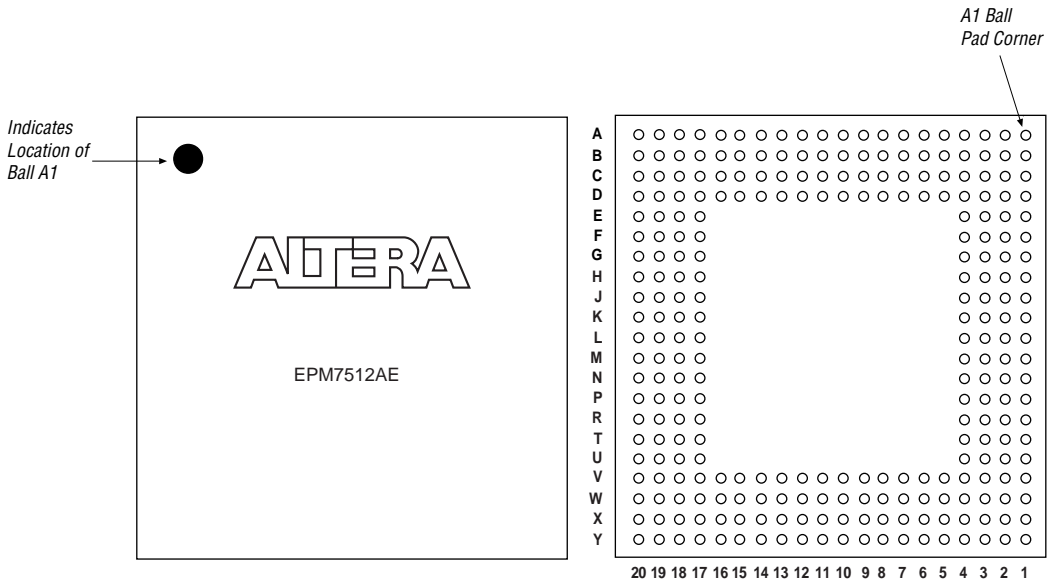
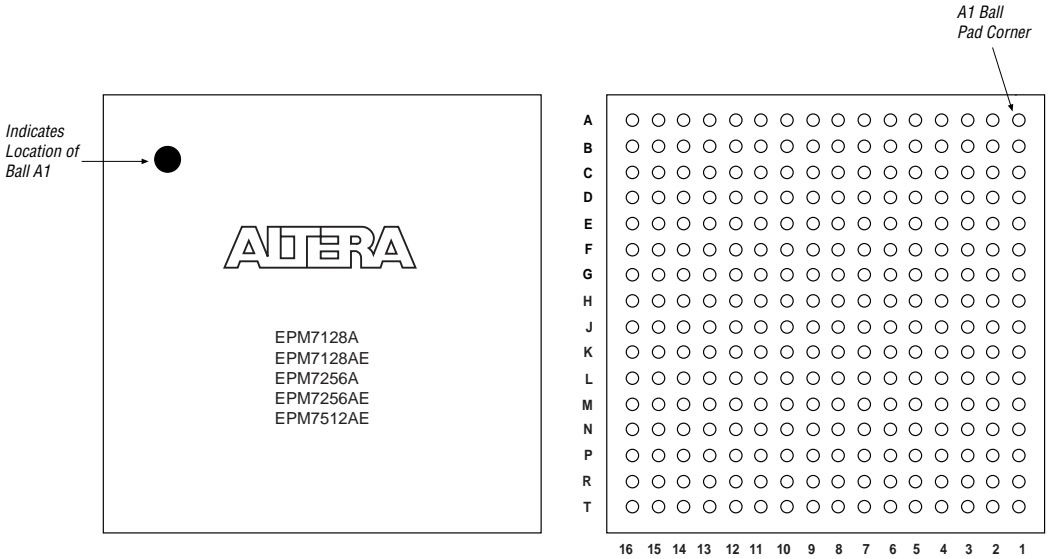

Figure 21. 256-Pin FineLine BGA Package Pin-Out Diagram

Package outline not drawn to scale.



## Revision History

The information contained in the *MAX 7000A Programmable Logic Device Family Data Sheet* version 2.03 supersedes information published in previous versions.

### Version 2.03 Changes

The *MAX 7000A Programmable Logic Device Family Data Sheet* version 2.03 contains the following change: 100-pin FineLine BGA package pin-out information added to [Tables 29](#) and [30](#).

## Version 2.02 Changes

The *MAX 7000A Programmable Logic Device Family Data Sheet* version 2.02 contains the following changes:

- EPM7256AE-5 device information was added throughout the document.
- MasterBlaster serial/USB communications cable was added throughout the document.
- ISP description was updated on [page 15](#).
- $t_{\text{C}PPW}$  timing parameter information was clarified in the “[Timing Model](#)” section.
- 256-pin BGA package diagram was corrected in [Figure 20](#).

## Version 2.01 Changes

The *MAX 7000A Programmable Logic Device Family Data Sheet* version 2.01 contained the following changes:

- [Note \(2\)](#) on [page 24](#) was updated.
- Minor stylistic changes were made throughout the data sheet.

Copyright © 1995, 1996, 1997, 1998, 1999 Altera Corporation, 101 Innovation Drive, San Jose, CA 95134, USA, all rights reserved.

By accessing this information, you agree to be bound by the terms of Altera's Legal Notice.