

1Megx32 Flash Module

The EDI7F341MV and EDI7F2341MV are organized as one and two banks of 1 Meg x 32 respectively. The modules are based on Intel's 28F008B3 - 1Megx8 Flash device in TSOP packages which are mounted on an FR4 substrate.

Both modules offer access times between 120 and 150ns allowing for operation of high-speed micro-processors without wait states.

Features

- 1 Meg x 32 and 2 x 1 Meg x 32 Densities
- Based on Intel's 28F008B3 Flash Device
- Fast Read Access Time - 120ns
- Flexible Smart Voltage
 - 2.7 - 3.6V Program Erase
 - 2.7 - 3.6 Read Operation
 - 12V Vpp Fast Production Programming
- Low Power Dissipation
 - 30mA per Device Active Current
 - 10µA per Device CMOS Standby Current
- Typical Endurance >100,000 Cycles
- Single 3.0 Volt -10% +20% Supply
- CMOS and TTL Compatible Inputs and Outputs
- Commercial and Industrial Temperature Range
- Package
 - 80 Pin SIMM (JEDEC)

Block Diagrams

EDI7F341MV-BNC
1Megx32 80 pin SIMM

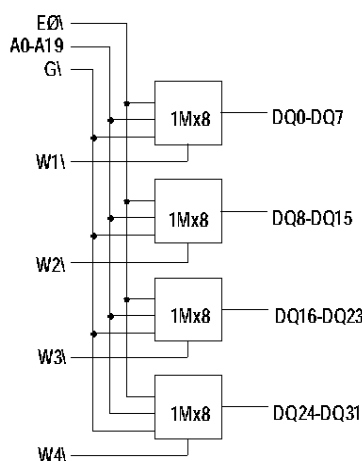

EDI7F2341MV-BNC
2x1Megx32 80 pin SIMM

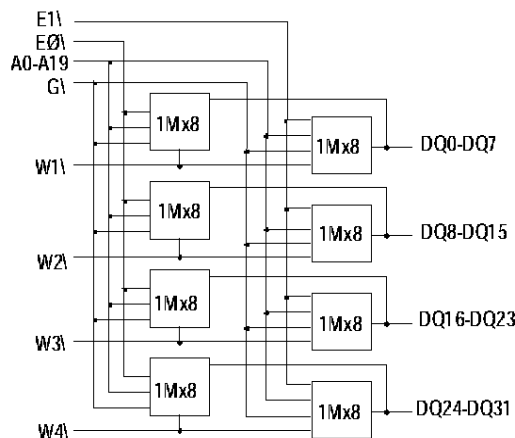

Electronic Designs Incorporated

• One Research Drive • Westborough, MA 01581 USA • 508-366-5151 • FAX 508-836-4850 •
Electronic Designs Europe Ltd. • Shelley House, The Avenue • Lightwater, Surrey GU18 5RF
 United Kingdom • 01276 472637 • FAX: 01276 473748
<http://www.electronic-designs.com>

Capacitance

(f=1.0MHz, VIN = VCC or VSS)

Parameter	Sym	1Meg	2x1Meg	Unit
		Max	Max	
Address Lines	CA	35	70	pF
Data lines	CDQ	15	30	pF
Chip & Write Enable Lines	CC	15	30	pF
Output Enable lines	CG	35	70	pF

Pin Configurations

Pin #	Pin Name	Pin #	Pin Name	Pin #	Pin Name	Pin #	Pin Name
1	VSS	21	*	41	A11	61	DQ9
2	VCC	22	*	42	A10	62	DQ8
3	VPP	23	*	43	A9	63	DQ7
4	G\	24	*	44	A8	64	DQ6
5	W0\	25	VSS	45	A7	65	DQ5
6	W1\	26	DQ29	46	A6	66	DQ4
7	NC	27	DQ30	47	A5	67	DQ3
8	DQ16	28	DQ31	48	A4	68	DQ2
9	DQ17	29	W2\	49	A3	69	DQ1
10	DQ18	30	NC	50	A2	70	DQ0
11	DQ19	31	NC	51	A1	71	VPP
12	DQ20	32	NC	52	A0	72	VCC
13	DQ21	33	A19	53	W3\	73	PD1
14	DQ22	34	A18	54	VSS	74	PD2
15	DQ23	35	A17	55	DQ15	75	PD3
16	DQ24	36	A16	56	DQ14	76	PD4
17	DQ25	37	A15	57	DQ13	77	PD5
18	DQ26	38	A14	58	DQ12	78	PD6
19	DQ27	39	A13	59	DQ11	79	PD7
20	DQ28	40	A12	60	DQ10	80	VSS

Simm Density		
Pin	1Meg	2x1Meg
21	NC	NC
22	NC	NC
23	NC	E1\
24	E0\	E0\

Presence Detect Pin Out		
Pin	1Meg	2x1Meg
PD1	NC	VSS
PD2	VSS	VSS
PD3	NC	NC
PD4	VSS	VSS

A0-A19 Address input
 E0\,E1\ Chip Enable
 W0\-W3\ Write Enable
 G\ Output Enable
 DQ0-DQ31 Data Input/Output
 PD Presence Detect
 VCC Power 3.0V -10% +20%
 VSS Ground
 NC No Connect
 VPP Program Power 2.7V - 12.5V

Ordering Information

Part Number	Speed (ns)	Package
EDI7F34IMV120BNC	120	362
EDI7F34IMV150BNC	150	362

Package No. 362

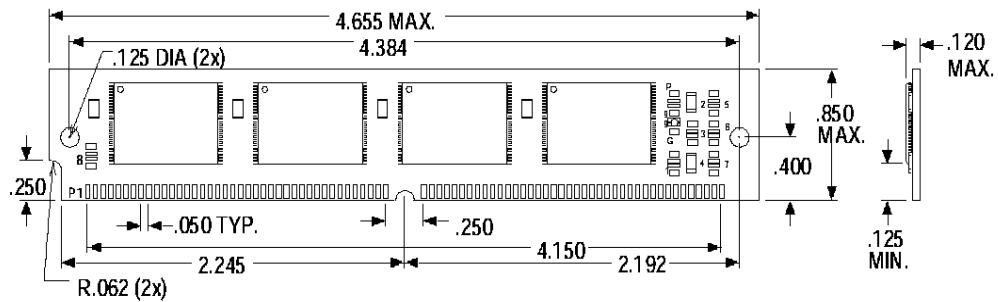

Part Number	Speed (ns)	Package
EDI7F234IMV120BNC	120	363
EDI7F234IMV150BNC	150	363

Package No. 363

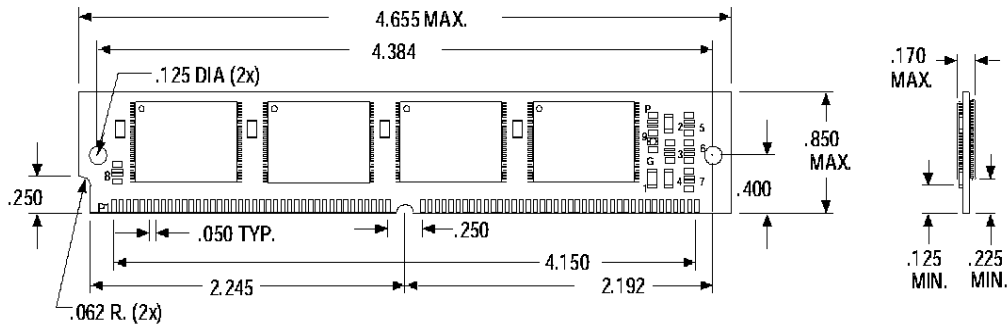

Electronic Designs Incorporated

• One Research Drive • Westborough, MA 01581USA • 508-366-5151 • FAX 508-836-4850 •
Electronic Designs Europe Ltd. • Shelley House, The Avenue • Lightwater, Surrey GU18 5RF
 United Kingdom • 01276 472637 • FAX: 01276 473748

<http://www.electronic-designs.com>

Electronic Designs Inc reserves the right to change specifications without notice. CAGE No. 66301