

NTC Thermistor: SCK Series

Power Thermistor for Inrush Current Limiter

■ Features

1. RoHS compliant
2. Body size $\Phi 5\text{mm} \sim \Phi 30\text{mm}$
3. Radial lead resin coated
4. High power rating
5. Wide resistance range
6. Cost effective
7. Operating temperature range :
 - $\Phi 5\text{mm}$: $-40 \sim +150^\circ\text{C}$
 - $\Phi 8 \sim \Phi 10\text{mm}$: $-40 \sim +170^\circ\text{C}$
 - $\Phi 13\text{mm} \sim \Phi 30\text{mm}$: $-40 \sim +200^\circ\text{C}$
8. Agency Recognition: UL /cUL/TUV /CSA/CQC

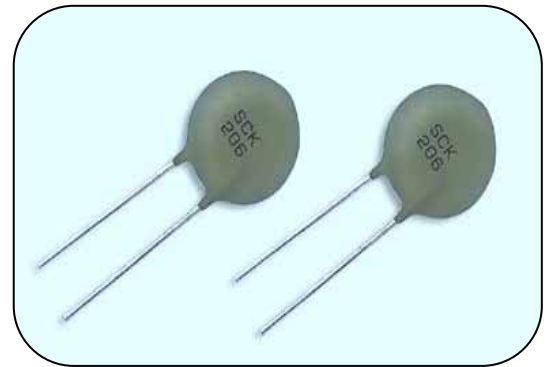

■ Recommended Applications

1. Switch mode power supply
2. Electric motor
3. Transformer
4. Adapter
5. Projector
6. Halogen lamp

■ Part No. Code

- $\Phi 5\text{mm} \sim \Phi 15\text{mm}$

1	2	3	4	5	6	7	8	9	10	11	12	13	14	15	16
Product Code		Body Size			Zero Power Resistance at 25°C (R ₂₅)		Max Steady State Current at 25°C		Tolerance of R ₂₅		Appearance		Internal Control Code		
SCK	Thinking NTC Thermistor SCK Type	05	$\Phi 5\text{mm}$	08	$\Phi 8\text{mm}$	0R5	0.5Ω	X3	0.3A	L	±15%	S	Straight Lead	Y	ROHS Control
		10	$\Phi 10\text{mm}$	2R5	2.5Ω	08	8Ω	2X	2.5A	M	±20%	I	Inner Kink Lead		
		13	$\Phi 13\text{mm}$	20	20Ω	20	20Ω	8	8A	N	±25%	F	Y Kink Lead		
		15	$\Phi 15\text{mm}$	120	120Ω	120	120Ω	10	10A						

- $\Phi 20\text{mm} \sim \Phi 30\text{mm}$

1	2	3	4	5	6	7	8	9	10	11	12	13	14	15	
Product Code		Body Size		Zero Power Resistance at 25°C (R ₂₅)			Tolerance of R ₂₅		Appearance		Packaging		Internal Control Code		
SCK	Thinking NTC Thermistor SCK Type	20	$\Phi 20\text{mm}$	R ₂₅ < 10Ω			L	±15%	S	Straight Lead	B	Bulk	Y	ROHS Control	
		25	$\Phi 25\text{mm}$	0R7:0.7Ω			M	±20%	I	Inner Kink Lead					
		30	$\Phi 30\text{mm}$	2R5:2.5Ω			N	±25%	F	Y Kink Lead					
				R ₂₅ ≥ 10Ω											
				100:10Ω											
				470:47Ω											
				471:470Ω											

NTC Thermistor: SCK Series

Power Thermistor for Inrush Current Limiter

■ Dimensions

S type (straight lead)

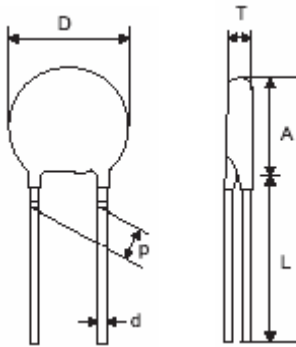

(Unit:mm)

Disc size	Dmax.	Pnor.	dnor.	Amax.	Lmin.	Tmax.
φ05	6.5	4±0.6	0.8±0.02	6.5	31	5
φ08	9.5	5±0.8	0.8±0.02	9.5	31	5
φ10	11.5	5±0.8	0.8±0.02	11.5	31	5
φ13	14.5	7.5±1	0.8±0.02	14.5	30	6
φ15	16.5	7.5±1	1±0.02	16.5	29	6
φ20	21.5	7.5±1	1±0.02	21.5	26	6
φ25	29	7.5±1	1±0.02	29	25	7
φ30	36	7.5±1	1±0.02	36	23	8

F type (Y kink lead)

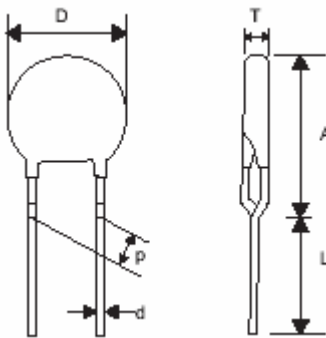

(Unit:mm)

Disc size	Dmax.	Pnor.	dnor.	Amax.	Lmin.	Tmax.
φ08	9.5	5±0.8	0.8±0.02	13	29	5
φ10	11.5	5±0.8	0.8±0.02	15	29	5
φ13	14.5	7.5±1	0.8±0.02	17.5	27	6
φ15	16.5	7.5±1	1±0.02	20	26	6
φ20	21.5	7.5±1	1±0.02	28	25	6
φ25	29	7.5±1	1±0.02	35	22	7
φ30	36	7.5±1	1±0.02	42	22	8

I type (inner kink lead)

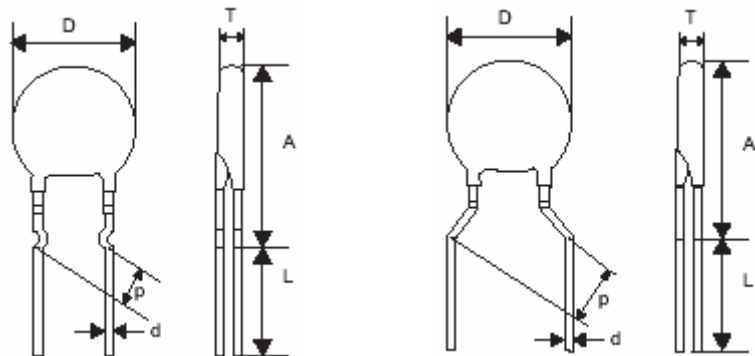

Figure A

Figure B

(Unit:mm)

Disc size	Dmax.	Pnor.	dnor.	Amax.	Lmin.	Tmax.	Figure
φ05	6.5	5±0.8	0.8±0.02	10	29	5	B
φ08	9.5	5±0.8	0.8±0.02	16	25	5	A
φ10	11.5	5±0.8	0.8±0.02	17	25	5	A
φ13	14.5	7.5±1	0.8±0.02	20	25	6	A
φ15	16.5	7.5±1	1±0.02	23	25	6	A
φ20	21.5	7.5±1	1±0.02	28	24	6	A
φ25	29	7.5±1	1±0.02	35	22	7	A
φ30	36	7.5±1	1±0.02	42	22	8	A

NTC Thermistor: SCK Series

Power Thermistor for Inrush Current Limiter

■ Characteristics

Part no.	Zero power resistance at 25°C	Max. steady state current at 25°C	Residual resistance at 25°C I _{max}	Max. power rating at 25°C	Thermal dissipation constant	Thermal time constant	Operating temperature range	Safety Approvals				
	R ₂₅ (Ω)	I _{max} (A)	R _{I_{max}} (Ω)	P _{max} (W)	δ(mW/°C)	τ(Sec.)	T _L ~T _U (°C)	UL	cUL	CSA	TUV	CQC
SCK05052□	5	2	0.429	1.8	15	17	-40 ~ +150	✓	✓	✓	✓	✓
SCK05081□	8	1	1.089					✓	✓	✓	✓	✓
SCK05101□	10	1	1.126					✓	✓	✓	✓	✓
SCK05121□	12	1	1.184					✓	✓	✓	✓	✓
SCK0520X3□	20	0.3	5.560					✓	✓	✓	✓	✓
SCK08042□	4	2	0.441	2.3	16	38	-40 ~ +170	✓	✓	✓	✓	✓
SCK084R72□	4.7	2	0.445					✓	✓	✓	✓	✓
SCK08053□	5	3	0.261					✓	✓	✓	✓	✓
SCK08063□	6	3	0.283					✓	✓	✓	✓	✓
SCK08073□	7	3	0.287					✓	✓	✓	✓	✓
SCK08082□	8	2	0.520					✓	✓	✓	✓	✓
SCK08102□	10	2	0.542					✓	✓	✓	✓	✓
SCK08152□	15	2	0.548					✓	✓	✓	✓	✓
SCK08201□	20	1	1.544					✓	✓	✓	✓	✓
SCK0830X□	30	0.5	4.094					✓	✓	✓	✓	✓
SCK10015□	1	5	0.091					2.4	17	43	-40 ~ +170	✓
SCK101R35□	1.3	5	0.095	✓	✓	✓	✓					✓
SCK101R55□	1.5	5	0.101	✓	✓	✓	✓					✓
SCK102R55A□	2.5	5	0.120	✓	✓	✓	✓					✓
SCK10035□	3	5	0.127	✓	✓	✓	✓					✓
SCK10044□	4	4	0.161	✓	✓	✓	✓					✓
SCK10054□	5	4	0.180	✓	✓	✓	✓					✓
SCK106R83□	6.8	3	0.270	✓	✓	✓	✓					✓
SCK10083□	8	3	0.278	✓	✓	✓	✓					✓
SCK10103□	10	3	0.297	✓	✓	✓	✓					✓
SCK10123□	12	3	0.301	✓	✓	✓	✓					✓
SCK10133□	13	3	0.356	✓	✓	✓	✓					✓
SCK10152X□	15	2.5	0.442	✓	✓	✓	✓					✓
SCK10162X□	16	2.5	0.471	✓	✓	✓	✓					✓
SCK10202□	20	2	0.646	✓	✓	✓	✓					✓
SCK10222□	22	2	0.659	✓	✓	✓	✓					✓
SCK10252□	25	2	0.674	✓	✓	✓	✓					✓
SCK10302□	30	2	0.700	✓	✓	✓	✓					✓
SCK10472□	47	2	0.720	✓	✓	✓	✓					✓
SCK10502□	50	2	0.813	✓	✓	✓	✓					✓
SCK10801□	80	1	2.236	✓	✓	✓	✓	✓				
SCK101001□	100	1	2.318	✓	✓	✓	✓	✓				
SCK101201□	120	1	2.406	✓	✓	✓	✓	✓				
SCK13013□	1	3	0.174	3.1	18	66	-40 ~ +200	✓	✓	✓	✓	✓
SCK131R37□	1.3	7	0.070					✓	✓	✓	✓	✓
SCK132R56□	2.5	6	0.094					✓	✓	✓	✓	✓
SCK13045□	4	5	0.132					✓	✓	✓	✓	✓
SCK134R74□	4.7	4	0.168					✓	✓	✓	✓	✓
SCK13055□	5	5	0.166					✓	✓	✓	✓	✓
SCK13074□	7	4	0.184					✓	✓	✓	✓	✓
SCK13084□	8	4	0.206					✓	✓	✓	✓	✓
SCK13104□	10	4	0.217					✓	✓	✓	✓	✓
SCK13124□	12	4	0.230					✓	✓	✓	✓	✓
SCK13153□	15	3	0.343					✓	✓	✓	✓	✓
SCK13163□	16	3	0.348					✓	✓	✓	✓	✓
SCK13183□	18	3	0.365					✓	✓	✓	✓	✓
SCK13203□	20	3	0.410					✓	✓	✓	✓	✓

NTC Thermistor: SCK Series

Power Thermistor for Inrush Current Limiter

Part no.	Zero power resistance at 25°C	Max. steady state current at 25°C	Residual resistance at 25°C I _{max}	Max. power rating at 25°C	Thermal dissipation constant	Thermal time constant	Operating temperature range	Safety Approvals				
	R ₂₅ (Ω)	I _{max} (A)	R _{I_{max}} (Ω)	P _{max} (W)	δ(mW/°C)	τ(Sec.)	T _L ~T _U (°C)	UL	cUL	CSA	TUV	CQC
SCK150R78A□	0.7	8	0.051	3.6	21	75	-40 ~ +200	√	√		√	√
SCK15018□	1	8	0.054					√	√			
SCK151R38□	1.3	8	0.064					√	√	√	√	√
SCK151R58□	1.5	8	0.068					√	√	√	√	√
SCK15028□	2	8	0.078					√	√		√	√
SCK152R58□	2.5	8	0.086					√	√	√	√	√
SCK15037□	3	7	0.091					√	√	√	√	√
SCK15046□	4	6	0.117					√	√	√	√	√
SCK15056□	5	6	0.121					√	√	√	√	√
SCK15065□	6	5	0.159					√	√	√	√	√
SCK15075□	7	5	0.161					√	√	√	√	√
SCK15085□	8	5	0.165					√	√		√	√
SCK15105□	10	5	0.178					√	√	√	√	√
SCK15125□	12	5	0.185					√	√	√	√	√
SCK15154□	15	4	0.261					√	√	√	√	√
SCK15164□	16	4	0.265					√	√	√	√	√
SCK15184□	18	4	0.273					√	√	√	√	√
SCK15204□	20	4	0.283					√	√	√	√	√
SCK15224□	22	4	0.308					√	√		√	√
SCK15253□	25	3	0.425					√	√	√	√	√
SCK15303□	30	3	0.461					√	√	√	√	√
SCK15333□	33	3	0.484					√	√		√	√
SCK15403□	40	3	0.511					√	√	√	√	√
SCK15473□	47	3	0.517					√	√	√	√	√
SCK15802X□	80	2.5	0.693	√	√	√	√	√				
SCK151202□	120	2	1.010	√	√	√	√	√				
SCK200R7□	0.7	15	0.035	4.9	28	113	-40~+200	√	√			√
SCK201R0□	1	13	0.034					√	√			√
SCK201R5□	1.5	10.5	0.041					√	√			√
SCK202R0□	2	10	0.062					√	√			√
SCK202R5□	2.5	9	0.083					√	√			√
SCK203R0□	3	8.5	0.078					√	√			√
SCK204R0□	4	8	0.080					√	√			√
SCK204R7□	4.7	7.5	0.114					√	√			√
SCK205R0□	5	7.5	0.118					√	√			√
SCK206R0□	6	7	0.120					√	√			√
SCK206R8□	6.8	6.5	0.130					√	√			√
SCK207R0□	7	6.5	0.132					√	√			√
SCK208R0□	8	6	0.161					√	√			√
SCK20100□	10	5.5	0.196					√	√			√
SCK20120□	12	5	0.197					√	√			√
SCK20130□	13	5	0.213					√	√			√
SCK20150□	15	4.5	0.258					√	√			√
SCK20160□	16	4.5	0.276					√	√			√
SCK20180□	18	4	0.280					√	√			√
SCK20200□	20	4	0.306					√	√			√

NTC Thermistor: SCK Series

Power Thermistor for Inrush Current Limiter

Part no.	Zero power resistance at 25°C	Max. steady state current at 25°C	Residual resistance at 25°C I _{max}	Max. power rating at 25°C	Thermal dissipation constant	Thermal time constant	Operating temperature range	Safety Approvals				
	R ₂₅ (Ω)	I _{max} (A)	R _{I_{max}} (Ω)	P _{max} (W)	δ(mW/°C)	τ(Sec.)	T _L ~T _U (°C)	UL	cUL	CSA	TUV	CQC
SCK251R0□	1	20	0.020	7.0	30	130	-40 ~ +200	√	√			√
SCK251R5□	1.5	18.5	0.023					√	√			√
SCK252R0□	2	18	0.025					√	√			√
SCK252R5□	2.5	15	0.032					√	√			√
SCK253R0□	3	14.5	0.042					√	√			√
SCK254R0□	4	14	0.044					√	√			√
SCK254R7□	4.7	13	0.052					√	√			√
SCK255R0□	5	12	0.061					√	√			√
SCK256R8□	6.8	10.5	0.082					√	√			√
SCK257R0□	7	10	0.092					√	√			√
SCK258R0□	8	9	0.115					√	√			√
SCK25100□	10	8	0.141					√	√			√
SCK25120□	12	7.5	0.164					√	√			√
SCK25150□	15	6.5	0.210					√	√			√
SCK25180□	18	5.5	0.231					√	√			√
SCK25200□	20	5	0.270					√	√			√
SCK301R0□	1	30	0.016	8.0	40	190	-40 ~ +200	√	√			√
SCK301R5□	1.5	25	0.020					√	√			√
SCK302R0□	2	23	0.022					√	√			√
SCK302R5□	2.5	18	0.030					√	√			√
SCK303R0□	3	17	0.035					√	√			√
SCK304R0□	4	16	0.048					√	√			√
SCK304R7□	4.7	15	0.055					√	√			√
SCK305R0□	5	14	0.057					√	√			√
SCK306R8□	6.8	12	0.077					√	√			√
SCK307R0□	7	11.5	0.084					√	√			√
SCK308R0□	8	10.5	0.100					√	√			√
SCK30100□	10	10	0.115					√	√			√
SCK30120□	12	9	0.142					√	√			√
SCK30150□	15	8	0.175					√	√			√
SCK30180□	18	7	0.210					√	√			√
SCK30200□	20	6	0.233					√	√			√

Note1 : □ = Tolerance of resistance

Note2: UL&cUL File No. E138827

CSA File No. 97495

TUV File No. R 50050155

CQC File No. CQC04001011942~944; CQC04001011963~965; CQC05001011984~985;

CQC05001011988~990; CQC05001011993

NTC Thermistor: SCK Series

Power Thermistor for Inrush Current Limiter

Maximum power rating (Pmax)

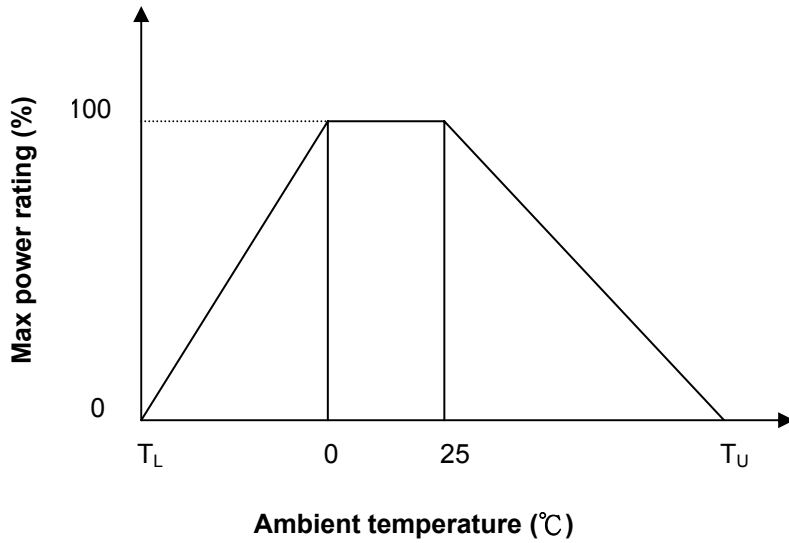

T_U: Maximum operating temperature

T_L: Minimum operating temperature

For example : Ambient temperature(T_a)=55°C

Maximum operating temperature(T_u)=200°C

$$P_{Ta} = (T_u - T_a) / (T_u - 25) \times P_{max} \approx 82\% P_{max}$$

R-T Characteristic Curve(representative)

SCK05052~SCK0520X3

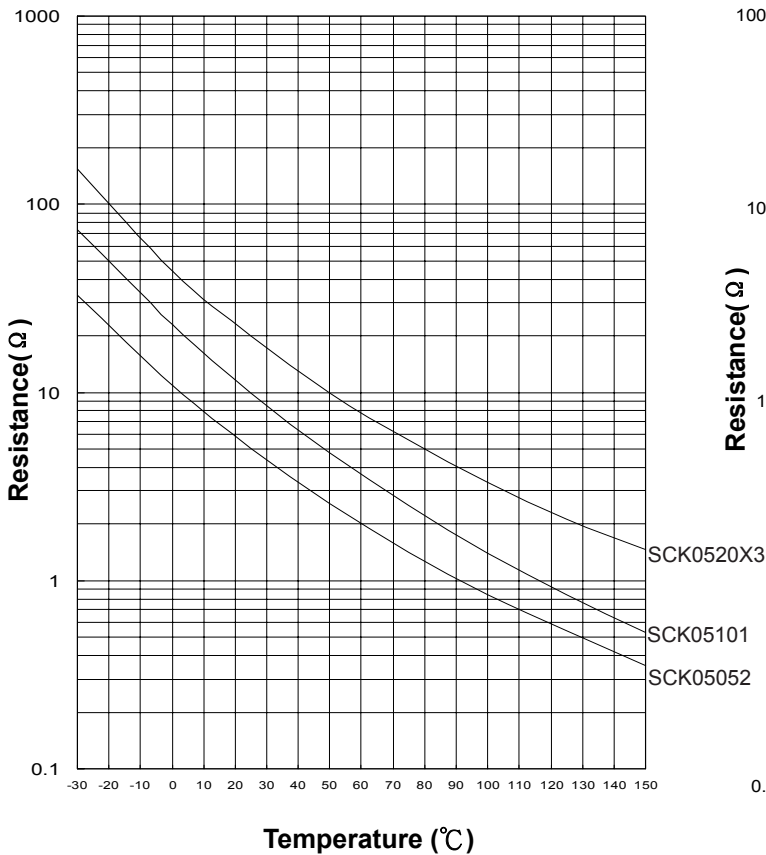

SCK08042~SCK08201

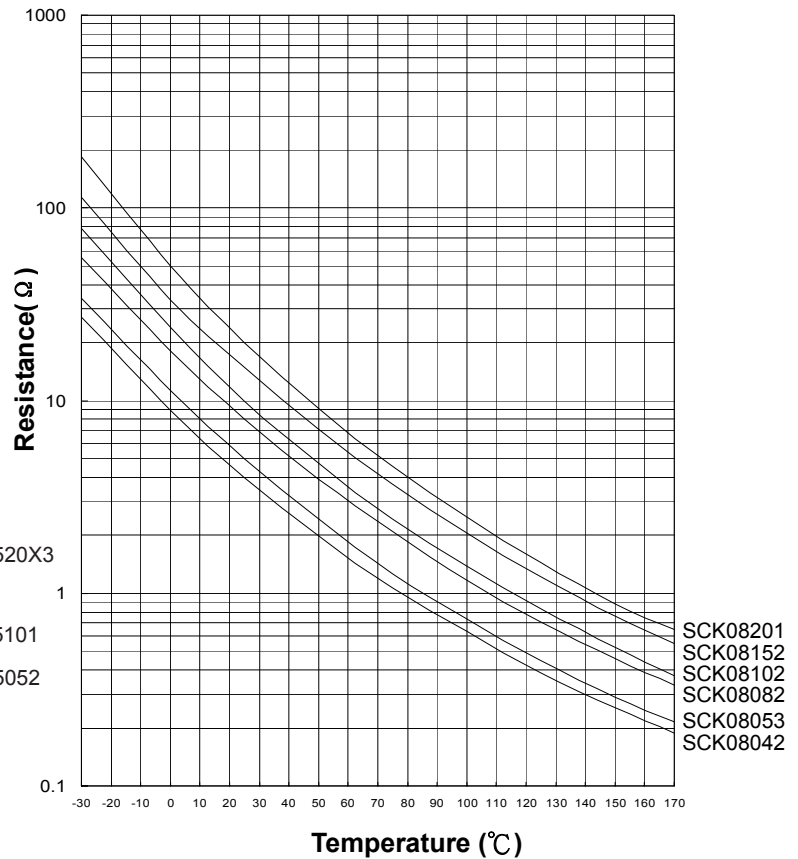

NTC Thermistor: SCK Series

Power Thermistor for Inrush Current Limiter

R-T Characteristic Curve(representative)

SCK10015~SCK101201

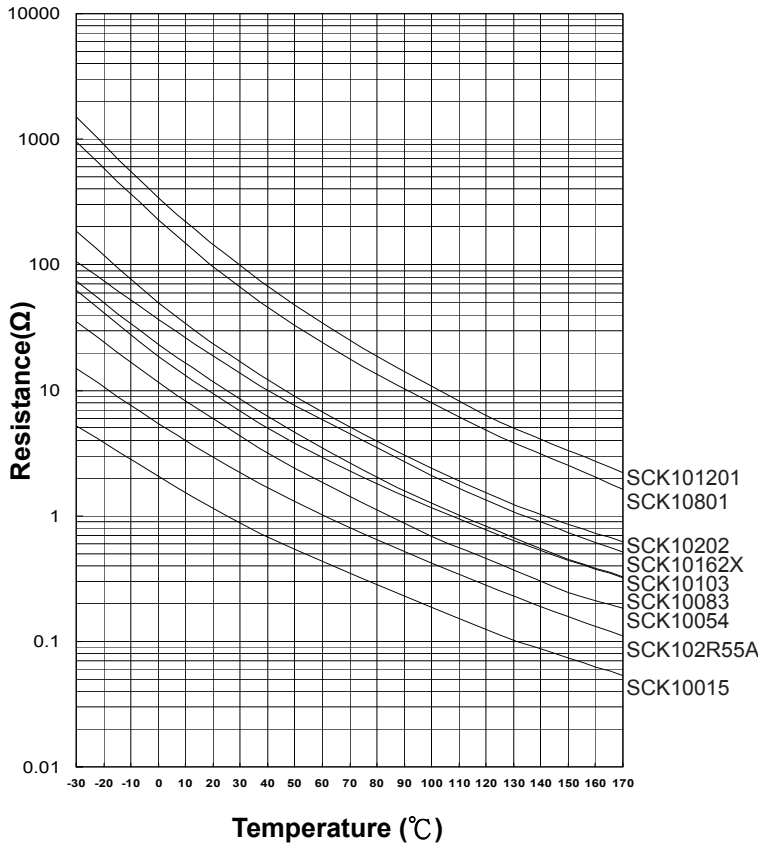

SCK131R37~SCK13203

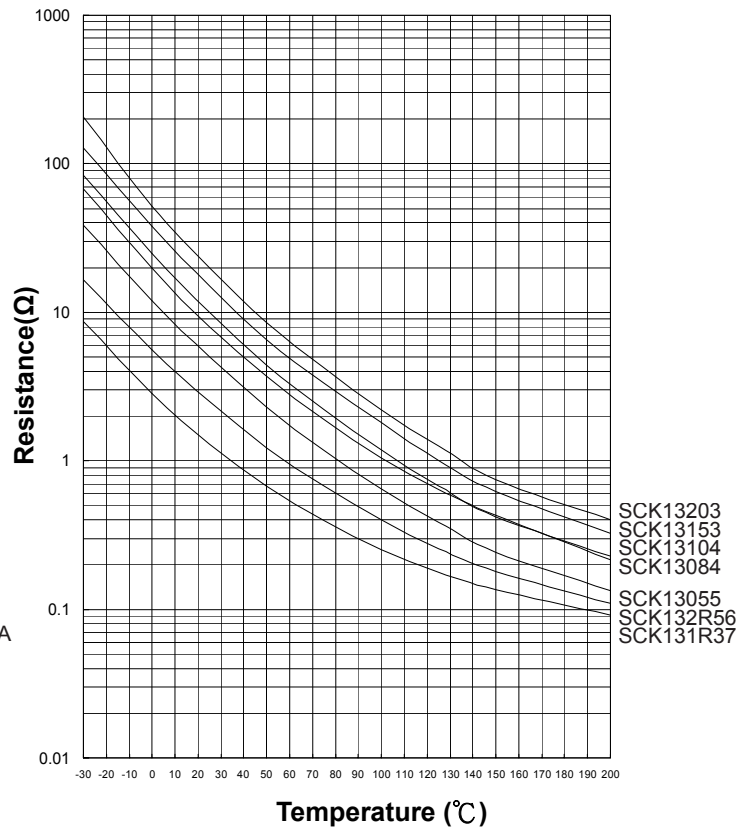

SCK151R38~SCK15473

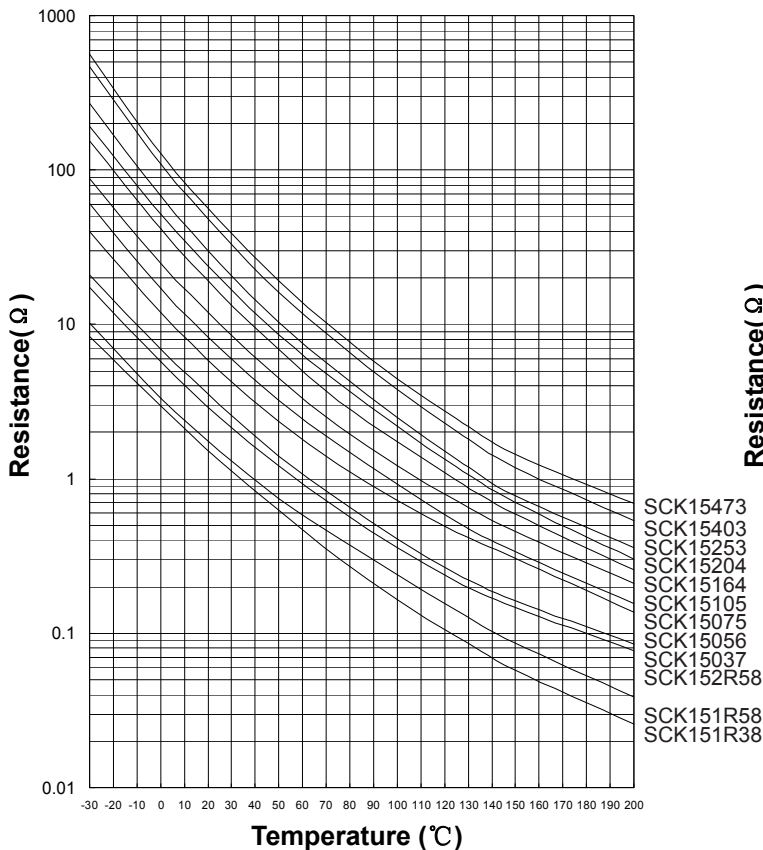

SCK201R0~SCK20200

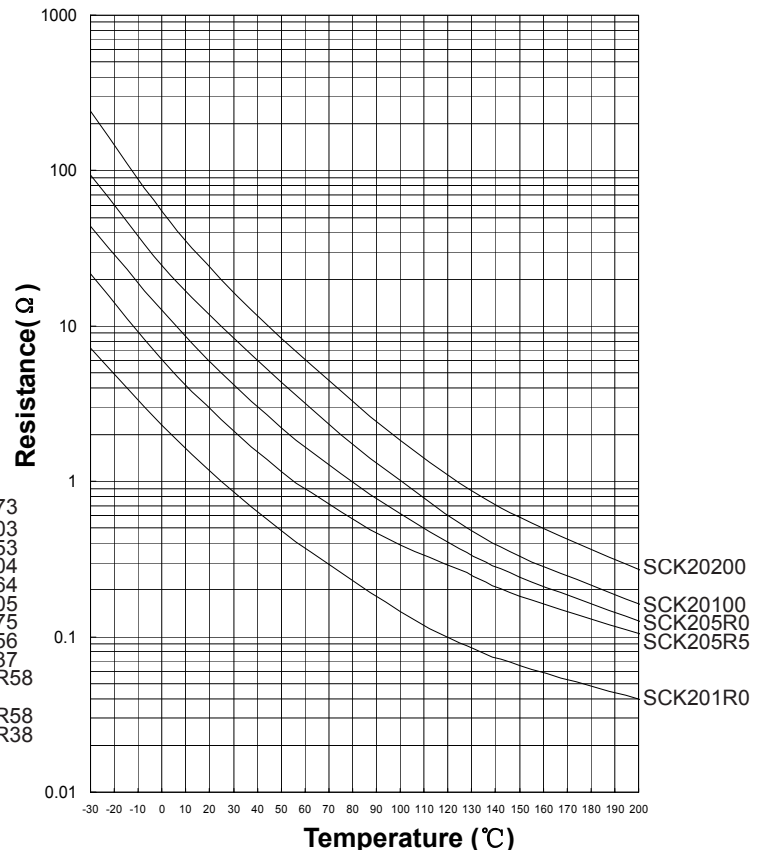

NTC Thermistor: SCK Series

Power Thermistor for Inrush Current Limiter

R-T Characteristic Curve(representative)

SCK251R0~SCK25200

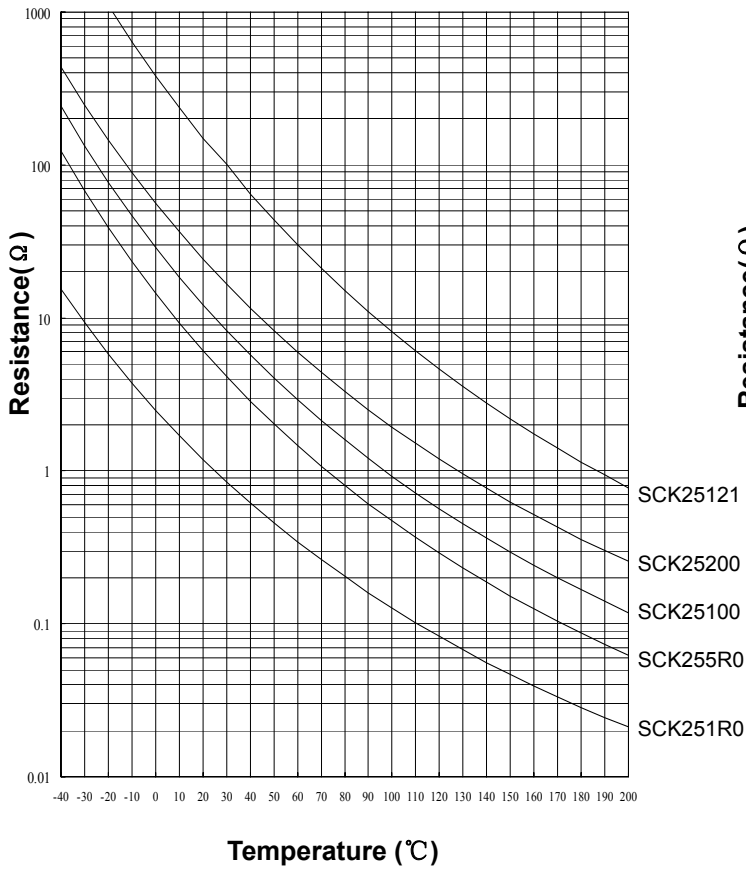

SCK301R0~SCK30100

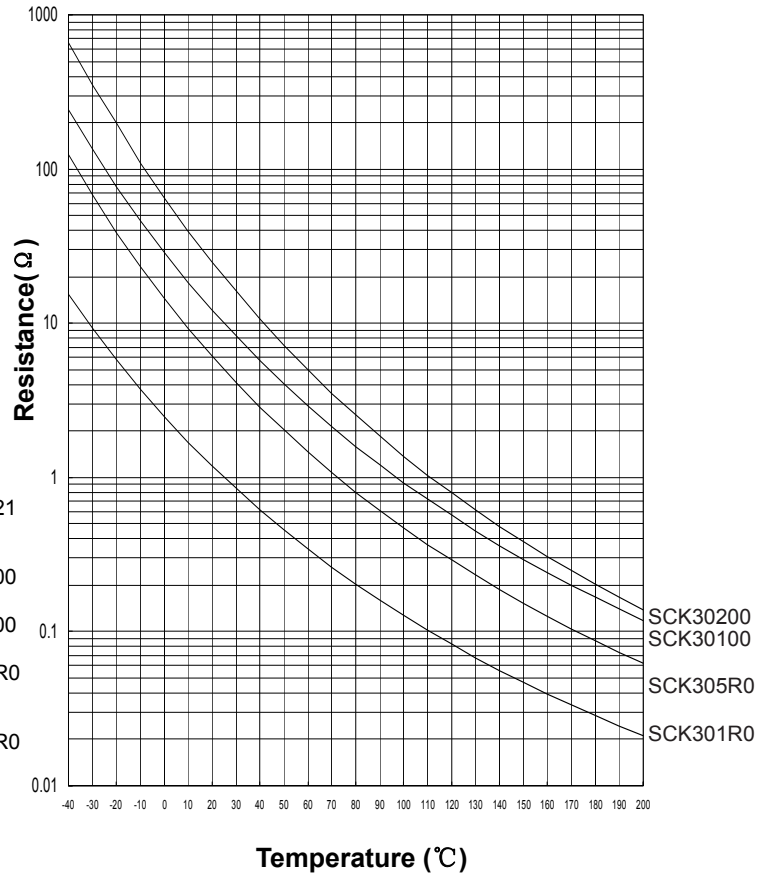

NTC Thermistor: SCK Series

Power Thermistor for Inrush Current Limiter

■ V-I characteristic curve (representative)

SCK05052~SCK0520X3

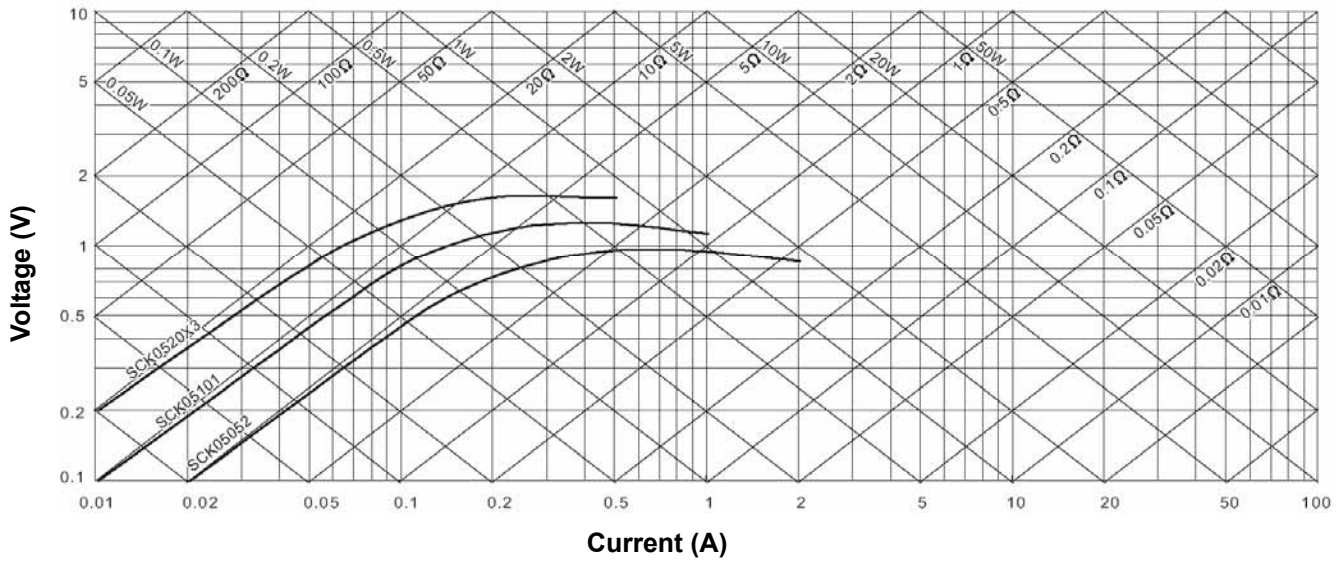

SCK08042~SCK08201

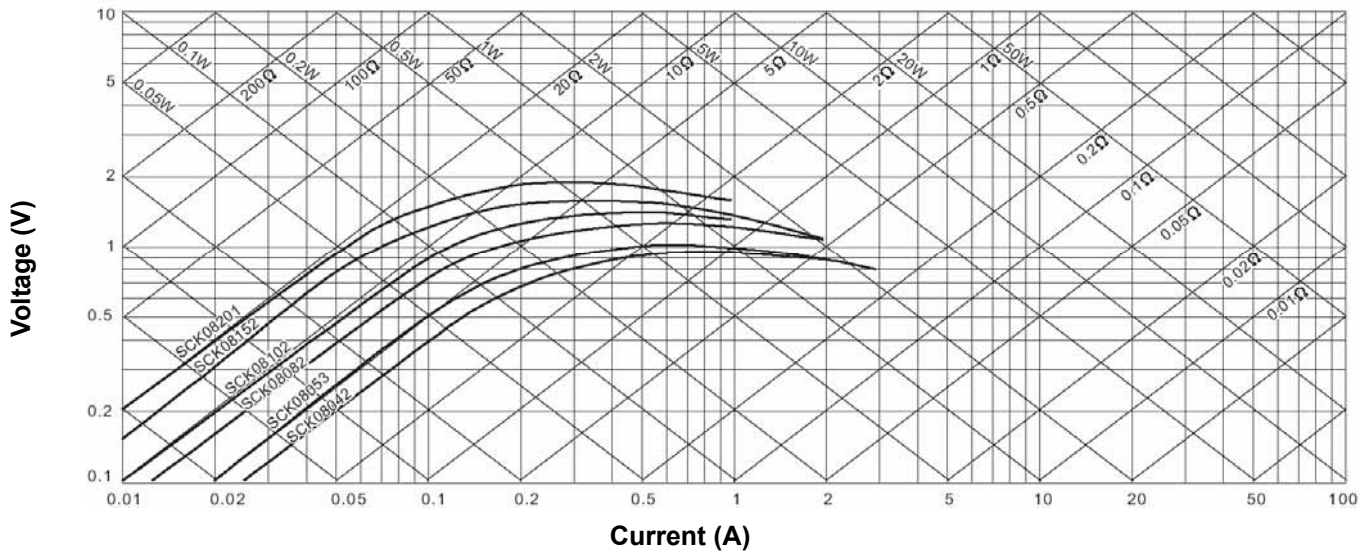

SCK10015~SCK101201

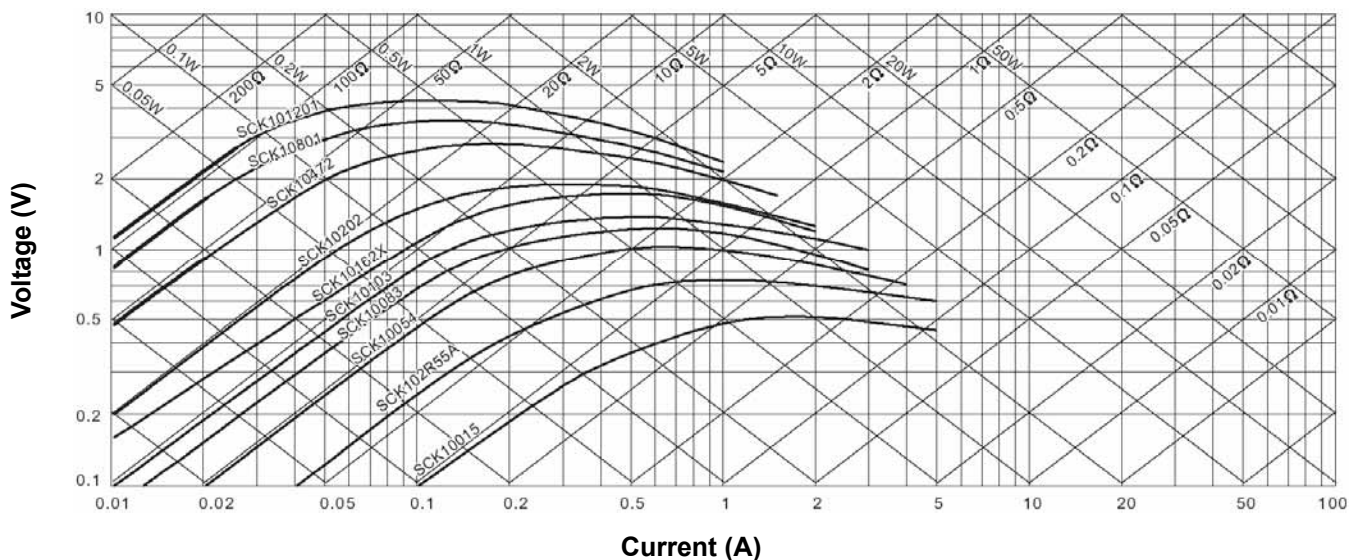

NTC Thermistor: SCK Series

Power Thermistor for Inrush Current Limiter

SCK251R0~SCK25121

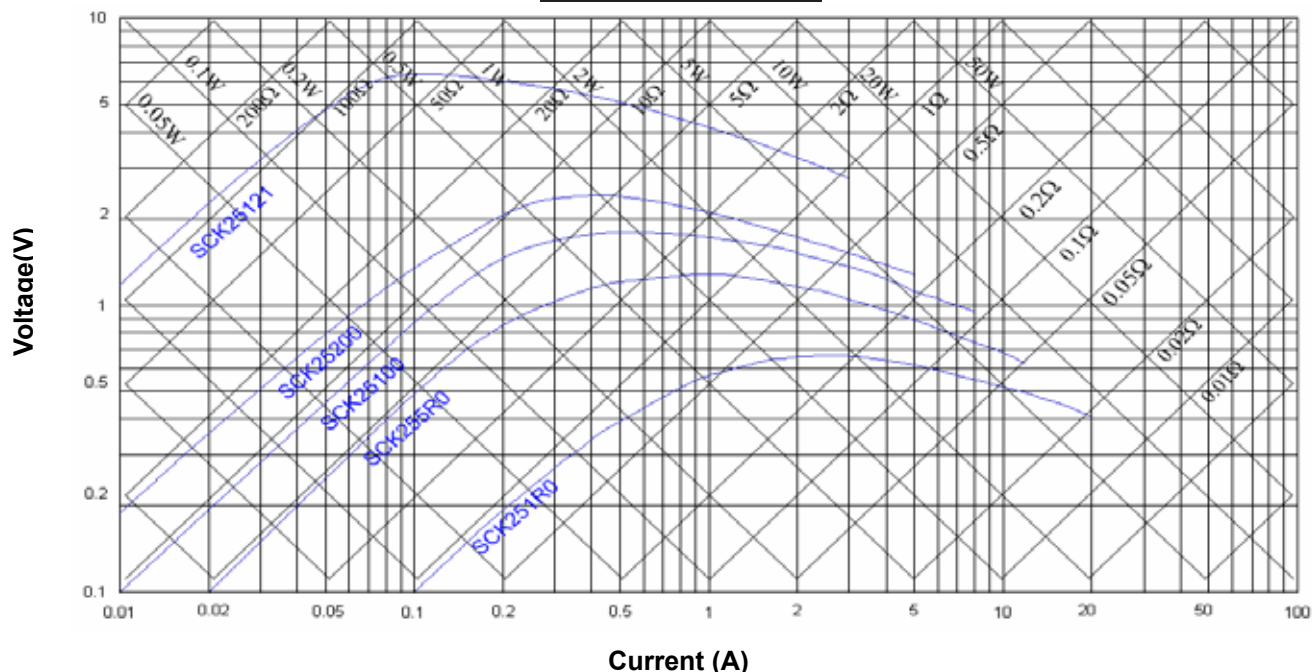

SCK301R0~SCK30200

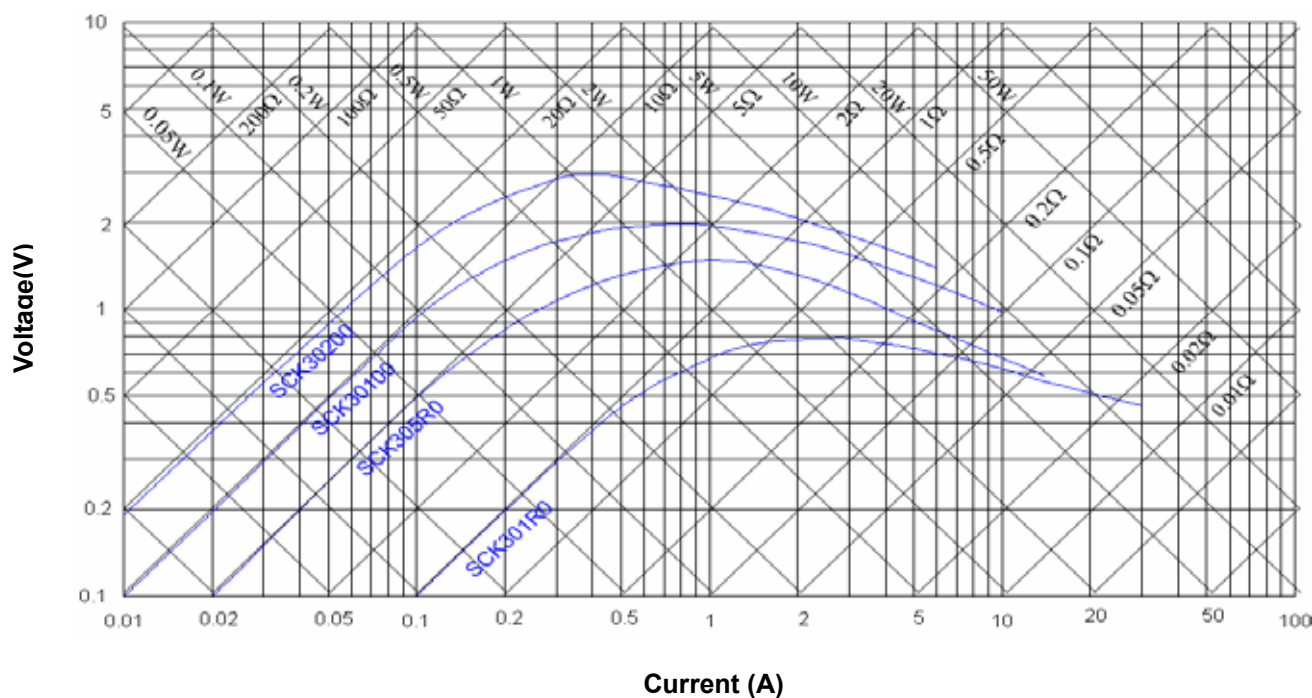

NTC Thermistor: SCK Series

Power Thermistor for Inrush Current Limiter

■ Recommended soldering condition

● Wave flow soldering profile

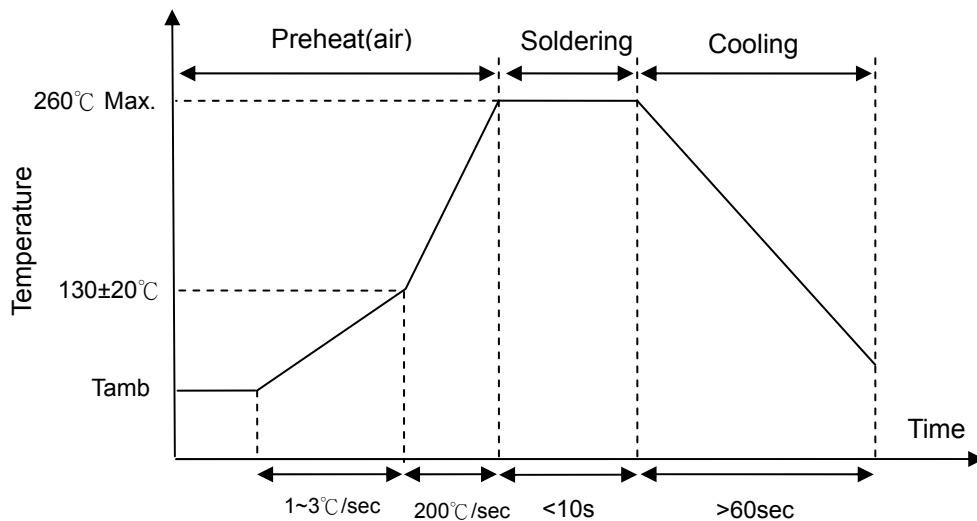

● Recommended Reworking Conditions With Soldering Iron

Item	Conditions
Temperature of Soldering Iron-tip	360°C (max.)
Distance from thermistor	2 mm (min.)
Soldering Time	3 sec (max.)

NTC Thermistor: SCK Series

Power Thermistor for Inrush Current Limiter

Reliability test

Item	Standard	Test Conditions / Methods	Specifications															
Tensile Strength of Terminals	IEC68-2-21	Gradually applying the force specified below to each terminal and keeping the unit fixed for 10 ± 1 sec <table style="width: 100%; border-collapse: collapse;"> <thead> <tr> <th style="text-align: center;">Terminal diameter (mm)</th> <th style="text-align: center;">Force (Kg)</th> </tr> </thead> <tbody> <tr> <td style="text-align: center;">$0.5 < d \leq 0.80$</td> <td style="text-align: center;">1.0</td> </tr> <tr> <td style="text-align: center;">$0.8 < d \leq 1.25$</td> <td style="text-align: center;">2.0</td> </tr> </tbody> </table>	Terminal diameter (mm)	Force (Kg)	$0.5 < d \leq 0.80$	1.0	$0.8 < d \leq 1.25$	2.0	No visible damage									
Terminal diameter (mm)	Force (Kg)																	
$0.5 < d \leq 0.80$	1.0																	
$0.8 < d \leq 1.25$	2.0																	
Solderability	IEC68-2-20	$235 \pm 5^\circ\text{C}$, 2 ± 0.5 sec	At least 95% of terminal electrode is covered by new solder															
Resistance to Soldering Heat	IEC68-2-20	$260 \pm 5^\circ\text{C}$, 10 ± 1 sec	No visible damage $ \Delta R/R \leq 10\%$															
High Temperature Storage	IEC68-2-2 UL1434	$T_{\text{max}} \pm 5^\circ\text{C}$ x 1000 ± 24 HRS	No visible damage $ \Delta R/R \leq 20\%$															
Damp Heat	IEC68-2-3 UL1434	$40 \pm 2^\circ\text{C}$, 90~95% RH , 1000 ± 24 HRS	No visible damage $ \Delta R/R \leq 20\%$															
Thermal Shock	IEC68-2-14 UL1434	The thermal shock conditions shown below shall be repeated 5 cycles <table border="1" style="width: 100%; border-collapse: collapse;"> <thead> <tr> <th>Step</th> <th>Temperature ($^\circ\text{C}$)</th> <th>Period (minutes)</th> </tr> </thead> <tbody> <tr> <td style="text-align: center;">1</td> <td style="text-align: center;">$T_{\text{min}} \pm 5$</td> <td style="text-align: center;">30 ± 3</td> </tr> <tr> <td style="text-align: center;">2</td> <td style="text-align: center;">Room temperature</td> <td style="text-align: center;">5 ± 3</td> </tr> <tr> <td style="text-align: center;">3</td> <td style="text-align: center;">$T_{\text{max}} \pm 5$</td> <td style="text-align: center;">30 ± 3</td> </tr> <tr> <td style="text-align: center;">4</td> <td style="text-align: center;">Room temperature</td> <td style="text-align: center;">5 ± 3</td> </tr> </tbody> </table>	Step	Temperature ($^\circ\text{C}$)	Period (minutes)	1	$T_{\text{min}} \pm 5$	30 ± 3	2	Room temperature	5 ± 3	3	$T_{\text{max}} \pm 5$	30 ± 3	4	Room temperature	5 ± 3	No visible damage $ \Delta R/R \leq 20\%$
Step	Temperature ($^\circ\text{C}$)	Period (minutes)																
1	$T_{\text{min}} \pm 5$	30 ± 3																
2	Room temperature	5 ± 3																
3	$T_{\text{max}} \pm 5$	30 ± 3																
4	Room temperature	5 ± 3																
Life Test	CNS5550	$25 \pm 5^\circ\text{C}$, I_{max} X 1000 ± 24 HRS	No visible damage $ \Delta R/R \leq 20\%$															
Endurance	UL1434	$25 \pm 5^\circ\text{C}$, I_{max} , C_T , 1min ON / 5 min OFF x 1000 cycles $C_T =$ Capacitance at 240 Vac	No visible damage $ \Delta R/R \leq 20\%$															
Insulation test	MIL-STD-202F -Method 302	$1000 V_{\text{DC}}$ 1 min	No visible damage $\geq 500 M\Omega$															

NTC Thermistor: SCK Series

Power Thermistor for Inrush Current Limiter

■ Packaging

● Taping Specification

For S (straight lead) type and F (Y kink lead) type

Figure A.

For S lead and F lead

Φ8 to Φ10 Type.

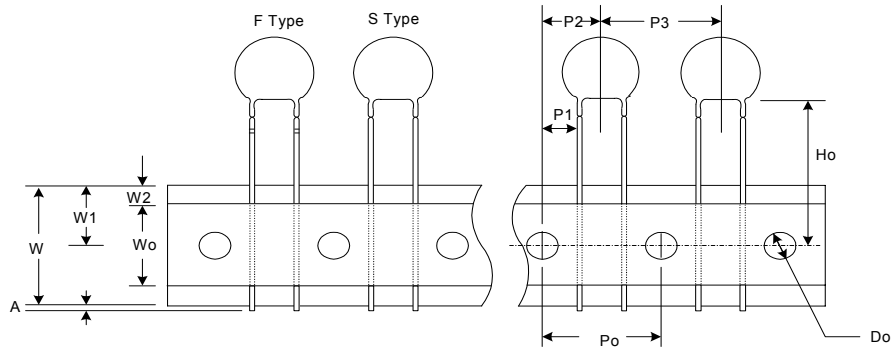

Figure B.

For S lead Φ13 to Φ20

type and F lead Φ13 to

Φ15 type

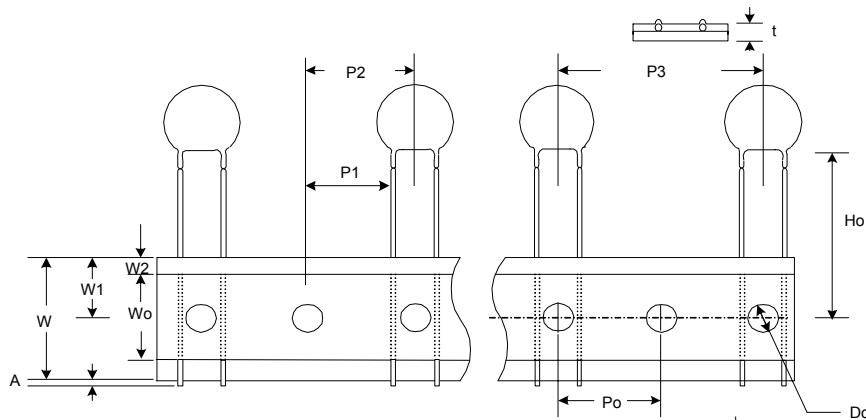
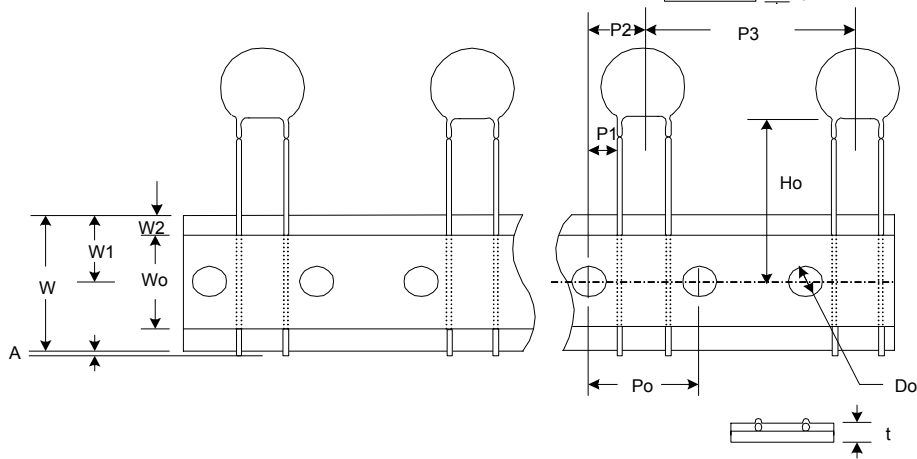

Figure C.

For S lead Φ13 to Φ20

type and F lead Φ13 to

Φ15 type



(Unit: mm)

Taping Code	Disc Size	P ₀	P ₁	P ₂	P ₃	H ₀	W ₀	W ₁	W ₂	W	A	D ₀	t	Figure
		±0.5	±0.7	±1.3	±0.5	±0.5	±1	±0.5	±1	±0.5	Max.	±0.2	±0.2	
A (P ₀ =12.7)	Φ08	12.7	3.45	6.35	12.7	20	12	9	3	18	1	4	0.6	A
	Φ10	12.7	3.45	6.35	12.7	20	12	9	3	18	1	4	0.6	A
	Φ13	12.7	8.55	12.7	25.4	20	12	9	3	18	1	4	0.6	B
	Φ15	12.7	8.45	12.7	25.4	20	12	9	3	18	1	4	0.6	B
	Φ20	12.7	8.45	12.7	25.4	20	12	9	3	18	1	4	0.6	B
E (P ₀ =15.0)	Φ08	15	4.6	7.5	15	20	12	9	3	18	1	4	0.6	A
	Φ10	15	4.6	7.5	15	20	12	9	3	18	1	4	0.6	A
	Φ13	15	3.35	7.5	30	20	12	9	3	18	1	4	0.6	C
	Φ15	15	3.25	7.5	30	20	12	9	3	18	1	4	0.6	C
	Φ20	15	3.25	7.5	30	20	12	9	3	18	1	4	0.6	C

NTC Thermistor: SCK Series

Power Thermistor for Inrush Current Limiter

For I type (inner kink lead)

Figure A.

For I lead $\Phi 5$ to $\Phi 10$ type.

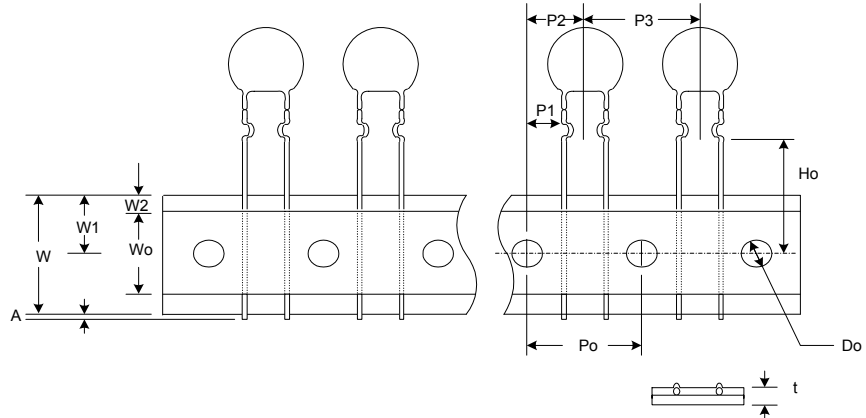

Figure B.

For I lead $\Phi 13$ to $\Phi 20$ type.

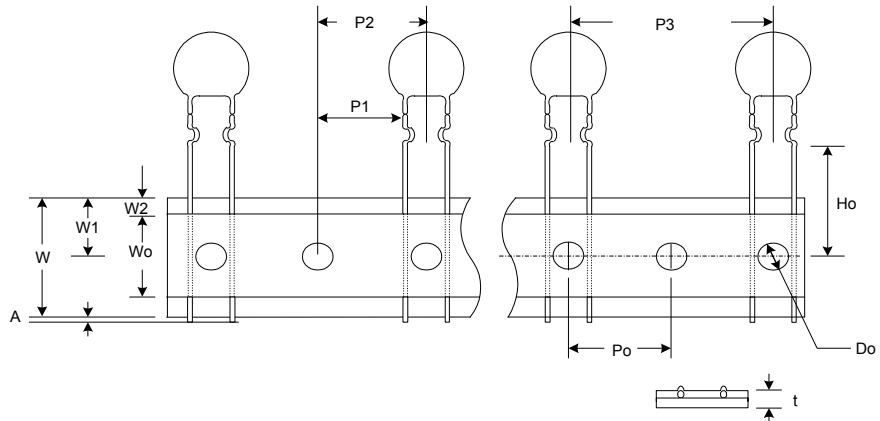

Figure C.

For I lead $\Phi 13$ to $\Phi 20$ type.

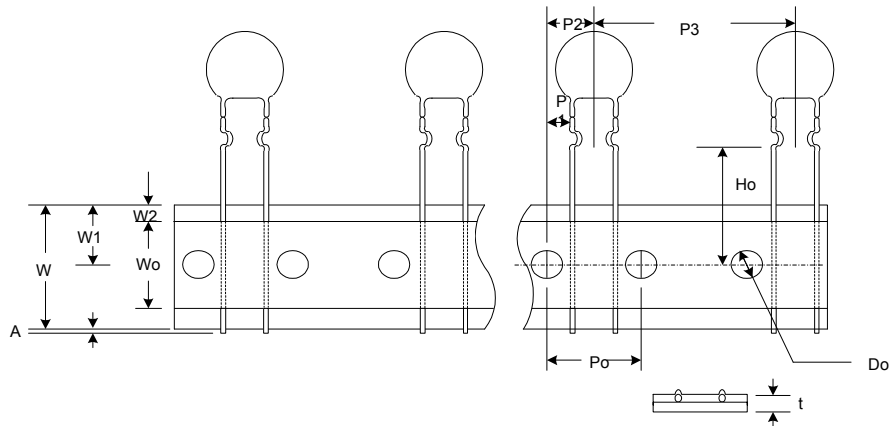
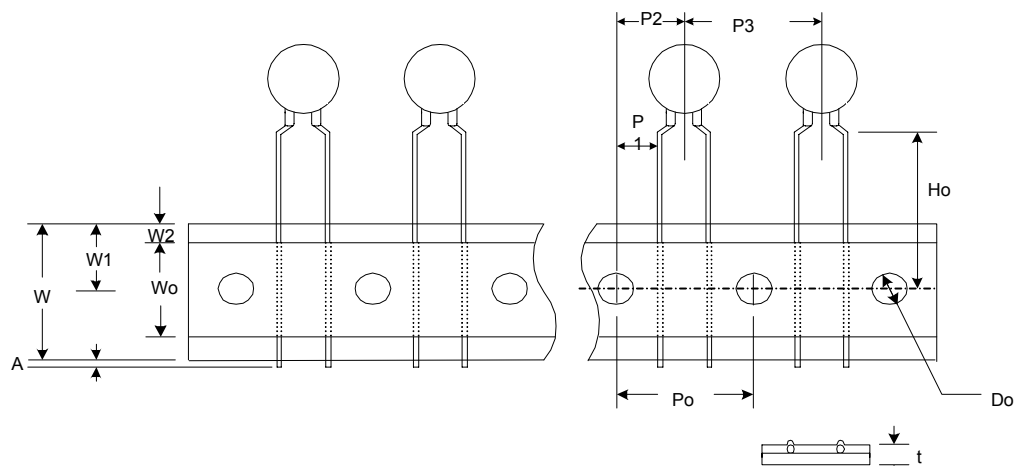

Figure D.

For I lead $\Phi 5$ type.



NTC Thermistor: SCK Series

Power Thermistor for Inrush Current Limiter

(Unit: mm)

Taping Code	Disc Size	P ₀	P ₁	P ₂	P ₃	H ₀	W ₀	W ₁	W ₂	W	A	D ₀	t	Figure
		±0.5	±0.7	±1.3	±0.5	±0.5	±1	±0.5	±1	±0.5	Max.	±0.2	±0.2	
A (P ₀ =12.7)	Φ05	12.7	3.45	6.35	12.7	16	12	9	3	18	1	4	0.6	D
	Φ08	12.7	3.45	6.35	12.7	16	12	9	3	18	1	4	0.6	A
	Φ10	12.7	3.45	6.35	12.7	16	12	9	3	18	1	4	0.6	A
	Φ13	12.7	8.55	12.7	25.4	16	12	9	3	18	1	4	0.6	B
	Φ15	12.7	8.45	12.7	25.4	16	12	9	3	18	1	4	0.6	B
	Φ20	12.7	8.45	12.7	25.4	16	12	9	3	18	1	4	0.6	B
E (P ₀ =15.0)	Φ05	15	4.6	7.5	15	16	12	9	3	18	1	4	0.6	D
	Φ08	15	4.6	7.5	15	16	12	9	3	18	1	4	0.6	A
	Φ10	15	4.6	7.5	15	16	12	9	3	18	1	4	0.6	A
	Φ13	15	3.35	7.5	30	16	12	9	3	18	1	4	0.6	C
	Φ15	15	3.25	7.5	30	16	12	9	3	18	1	4	0.6	C
	Φ20	15	3.25	7.5	30	16	12	9	3	18	1	4	0.6	C

■ Quantity

● Bulk Packing

Disc Size/mm	Quantity (PCS/Bag)
Φ05	200
Φ08	200
Φ10	200
Φ13	100
Φ15	100
Φ20	50
Φ25	20
Φ30	20

● Reel Packing

Disc Size/mm	Quantity (PCS/Reel)
Φ05	2500
Φ08	1500
Φ10	1500
Φ13	750
Φ15	750
Φ20	500

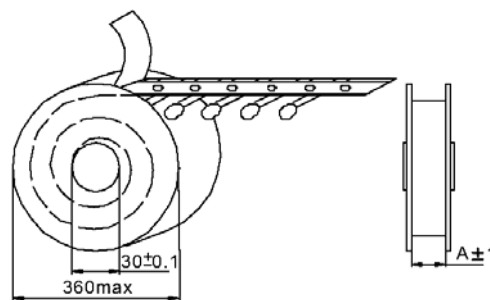

Disc Size	Φ05	Φ08~Φ20
A	40mm	55mm

NTC Thermistor: SCK Series

Power Thermistor for Inrush Current Limiter

● Ammo packing

Disc Size/mm	Quantity (PCS/Box)
Φ05	1000
Φ08	1000
Φ10	1000
Φ13(P ₀ =12.7)	500
Φ13(P ₀ =15)	1000
Φ15	500
Φ20	500

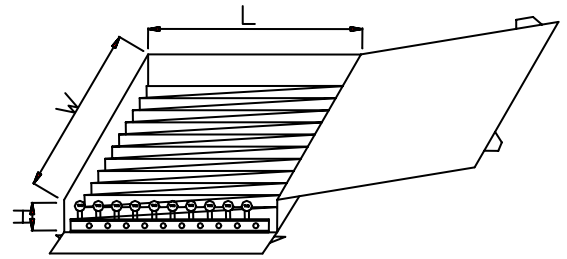

W	L	H
348mm	275mm	60mm

■ Storage condition of products

● Storage Conditions :

1.Storage Temperature : -10°C~+40°C

2.Relative humidity : ≤75%RH

3.Thermistors must be kept away from sunlight and stored in a non-corrosive atmosphere.

● Period of Storage : 1 year