



### **Specification Control Drawing**

#### **Scope**

- Scope
- Part Number

#### **Applicable Documents**

- Specifications and Standards

#### **Requirements**

- General Requirements
- Approved Manufacturer
- Design and Construction
  - Outline Dimensions and Terminal Connections
  - Package Body and Lead Finish
  - Active Devices
- Performance Requirements
  - Maximum Ratings
  - Electrical Performance Characteristics and Limits
  - Delta Limits
  - Total Dose Radiation Limits

#### **Quality Assurance Provisions**

- General
- Screening Tests
- Quality Conformance Inspection

#### **Packaging**

- Preservation, Packaging and Packing

#### **Notes**

- Ordering Information
- Part Number
- Table I.** Stability/Temperature Options

#### **Source of Supply**

- Approved Manufacturer

**Table II.** Maximum Ratings

**Table III.** Electrical Performance Characteristics

**Figure 1.** Package Dimensions and Terminal Connections

REVISIONS			
REVISION	DESCRIPTION	DATE	APPROVED
-	Initial release		
A	Modify tr/lf spec limits to better reflect output buffer drive capability.	2-27-07	
B	Clarify temperature stability definitions, Table I.	3-19-07	
C	Modify paragraph 3.3.3 for clarification of microcircuit technology, SEL rating	7/17/07	
D	Change to microcircuit manufacturer, paragraph 3.3.3	8/08/08	E.Jackson

**THIS DOCUMENT IS CONSIDERED PROPRIETARY TO Q-TECH CORPORATION  
DO NOT COPY OR DISTRIBUTE WITHOUT Q-TECH CORPORATION APPROVAL**

SPECIFICATION CONTROL DRAWING			Q-TECH CORPORATION 10150 W. JEFFERSON BLVD. CULVER CITY, CA. 90232-3510				
UNLESS OTHERWISE SPECIFIED DIMENSIONS ARE IN INCHES.  TOLERANCES: 3 PLACE DECIMAL = .005 2 PLACE DECIMAL = .02 1 PLACE DECIMAL = .1  FRACTIONS = ± 1/16 ANGLES = 2 DEGREES	PREPARED BY	DATE	<b>HYBRID CRYSTAL OSCILLATOR +3.3V, CLASS S, DETAIL SPECIFICATION FOR</b>				
	E.Jackson	8/8/08					
	CHECKED BY	DATE	DRAWING NO.		REV.		
	T.Villegas	10/9/08	<b>QT625L</b>		<b>D</b>		
	RELEASED BY	DATE	SCALE:	SIZE	CAGE CODE	SHEET 1 of 5	
	M.Dao	10/15/08	<b>NONE</b>	<b>A</b>	<b>51774</b>		

**1 SCOPE**

- 1.1 Scope. This specification establishes the detail requirements for hybrid, hermetically sealed, crystal oscillators for use in space flight missions.
- 1.2 Part number. The part number shall be as specified in Table I herein.

**2 APPLICABLE DOCUMENTS**

- 2.1 Specifications and standards. Unless otherwise specified, the following documents shall be applicable to this specification to the extent specified herein.

**SPECIFICATIONS**

401-0298-001                      Hybrid Crystal Oscillators, Class S, General Specification For

**3 REQUIREMENTS**

- 3.1 General requirements. The individual item requirements shall be as specified in the General Specification with the exceptions, modifications, and additions specified herein.
- 3.2 Approved manufacturer. Hybrid crystal oscillators shall be supplied from the manufacturer specified in paragraph 7.1 herein.
- 3.3 Design and construction.
  - 3.3.1. Outline dimensions and terminal connections. The outline dimensions and terminal connections shall be as shown in Figure 1 herein.
  - 3.3.2. Package body and lead finish. The package body and lead finish shall be gold in accordance with MIL-PRF-38534.
  - 3.3.3. Active Devices. The microcircuit used in this part shall use CMOS technology and shall be from a wafer proven to be radiation tolerant to 100 kRad (Si) total ionizing dose.
  - 3.3.3.1 CMOS microcircuit usage. For frequencies below 12 MHZ the output microcircuit shall be Intersil Corporation 54ACS family, Silicon on Sapphire CMOS technology, from a wafer proven to be radiation tolerant to 300 kRad (Si). For frequencies greater than or equal to 12 MHZ, the CMOS microcircuit shall be 54AC00, see DSSC SMD 5962-87549. This microcircuit is specified to be *single event latchup free* for LET up to 93 MeV-cm<sup>2</sup>/mg. For output frequencies from 12 MHZ to 70 MHZ, the manufacturer shall be ST Microelectronics Corporation; for output frequencies greater than or equal to 70 MHZ, the manufacturer shall be National Semiconductor Corporation.
- 3.4 Performance requirements.
  - 3.4.1. Maximum ratings. The maximum ratings shall be as specified in Table II herein.
  - 3.4.2. Electrical performance characteristics and limits. The electrical performance requirements and limits shall be in accordance with Table III herein.
  - 3.4.3. Delta limits. Except for frequency aging (refer to Table III), delta limits shall be in accordance with the General Specification.
  - 3.4.4. Total dose radiation limits. Hybrid crystal oscillators supplied in accordance with this specification shall be capable of meeting the performance requirements after being exposed to 100 krad total dose radiation levels.

**4 QUALITY ASSURANCE PROVISIONS**

- 4.1 General. The quality assurance provisions shall be in accordance with the General Specification with the exceptions, modifications, and additions specified herein.
- 4.2 Screening tests. The screening tests shall be in accordance with the General Specification.
- 4.3 Quality Conformance Inspection. Quality Conformance Inspection shall be in accordance with the General Specification and shall be required only when specified by the purchase order.

**5 PACKAGING**

- 5.1 Preservation, packaging and packing. Hybrid crystal oscillators shall be prepared for delivery in accordance with the General specification.

**6 NOTES**

- 6.1 Notes. The notes of the General Specification are applicable to this drawing.
- 6.2 Ordering information. The procuring activity shall advise Q-Tech Corporation at the time of Request for Quotation if quality conformance inspection is to be required.
- 6.3 Part number.

QT625 L B M - 16.000000 MHZ

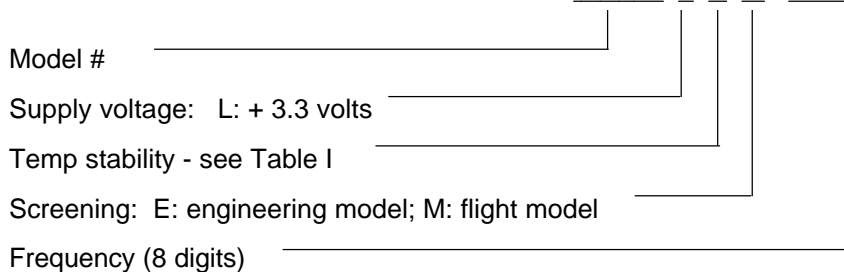

<b>TABLE I. STABILITY / TEMPERATURE OPTIONS *</b>	
<b>OPTION</b>	<b>TEMP STABILITY</b>
<b>A</b>	± 65 PPM, - 55 °C TO + 125 °C
<b>B</b>	± 50 PPM, - 55 °C TO + 125 °C
<b>C</b>	± 50 PPM, - 55 °C TO + 105 °C
<b>D</b>	± 40 PPM, - 55 °C TO + 105 °C
<b>E</b>	± 30 PPM, - 40 °C TO + 85 °C
<b>F</b>	± 50 PPM, - 20 °C TO + 70 °C
<b>G</b>	± 25 PPM, - 20 °C TO + 70 °C
<b>H *</b>	± 5 PPM, 0 °C TO + 55 °C

\* Frequency/Temperature stability (tolerance) shall be referenced to the specified nominal output frequency, except for temp code H, in which case it is with reference to room temperature (T = 25 ± 2 °C). For temp code H, room temperature tolerance shall be ±10 PPM.

**7 SOURCE OF SUPPLY**

- 7.1 Approved manufacturer.  
  
 Q-Tech Corporation  
 10150 W. Jefferson Blvd.  
 Culver City, Ca. 90232 U.S.A.

**TABLE II. MAXIMUM RATINGS**

Parameter	Symbol	Min	Max	Units
Supply voltage	V <sub>CC</sub>	0	7	Volts
Operating temperature	T <sub>C</sub>	-55	125	°C
Storage temperature	T <sub>stg</sub>	-65	150	°C
Lead solder temperature/time			250/10	°C/seconds
Package thermal resistance	θ <sub>jc</sub>		50	°C/W

**TABLE III. ELECTRICAL PERFORMANCE CHARACTERISTICS**

ELECTRICAL PARAMETER	TEST CONDITIONS 2/, 3/	LIMITS				NOTES
		MIN.	NOM.	MAX.	UNITS	
FREQUENCY RANGE		2.5		150	MHz	
FREQUENCY/TEMPERATURE STABILITY		See Table I				1/, 4/
SUPPLY VOLTAGE		3	3.3	3.6	Vdc	
INPUT CURRENT	<b>Output frequency:</b>					
Measured without load at 3.63 Vdc	Less than 12 MHZ			7	mA	
	12 MHZ - 59.99 MHZ			15	mA	
	60 MHZ - 99.99 MHZ			20	mA	
	100 MHZ - 150 MHZ			30	mA	
LOAD			CMOS		-	6/
OUTPUT VOLTAGE - LOGIC "0"				V <sub>CC</sub> x 0.1	Vdc	5/
OUTPUT VOLTAGE - LOGIC "1"		V <sub>CC</sub> x 0.9			Vdc	
OUTPUT WAVEFORM		Squarewave			N/A	
	<b>Output frequency:</b>					
RISE / FALL TIME @ worst case, V <sub>CC</sub> = 3.0, T = 125 °C	Below 70 MHZ			4	nS	6/
	70 MHZ - 125 MHZ			3	nS	6/
	> 125 MHZ			2.5	nS	6/
DUTY CYCLE		60/40 or better			%	
FREQUENCY AGING (AFTER 30 DAYS)	70 °C ± 3 °C			±1.5	ppm	
FREQUENCY AGING (AFTER 1 YEAR)	70 °C ± 3 °C			±10	ppm	
STARTUP TIME				10	ms	

**NOTES**

1. The limit for frequency/temperature stability (tolerance) shall be referenced to the specified nominal output frequency, except for temp code H as noted above.
2. Unless otherwise specified, the limits are over the full operating temperature range and under specified load conditions.
3. Unless otherwise specified, all measurements are in accordance with MIL-PRF-55310.
4. Up to 30 days after shipment.
5. Voltage values are with respect to network ground terminal.
6. A standard CMOS load of 10 kOhm || 15 pF shall be used, except for frequencies greater than 125 MHZ, where the load shall be 5 pF. See MIL-PRF-55310/26 for CMOS waveform measurement definitions.

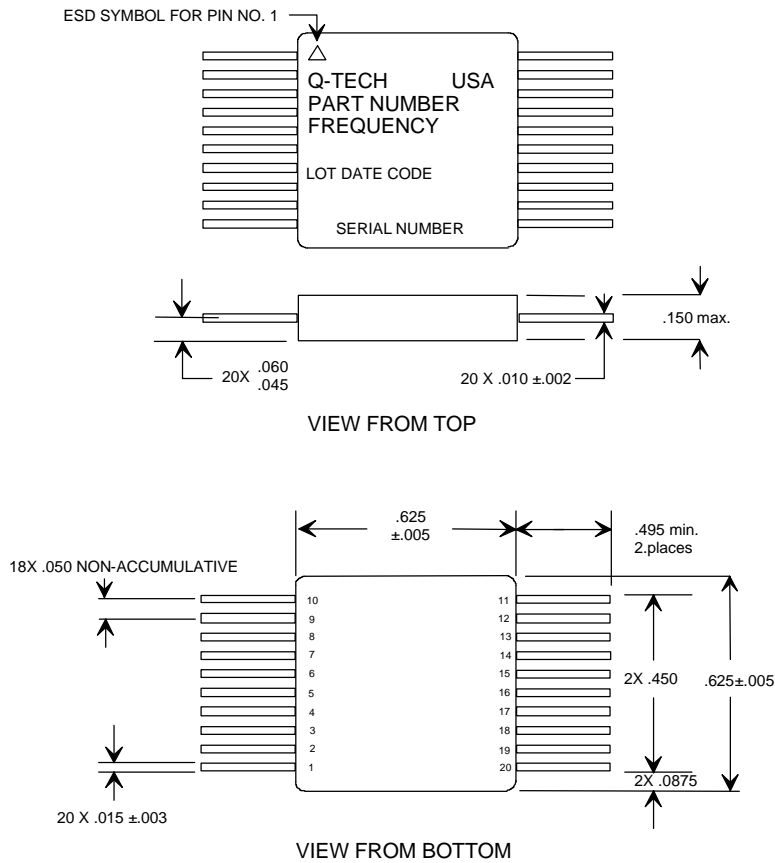

**NOTES:**

1. Dimensions are in inches.
2. Lead numbers are for reference only and are not marked on the unit.
3. All pins with function NC may not be connected as external tie or connections, except they may be tied to Ground.

<b>TERMINAL CONNECTIONS</b>			
<b>TERMINAL NO.</b>	<b>CONNECTION</b>	<b>TERMINAL NO.</b>	<b>CONNECTION</b>
1	N/C	11	OUTPUT
2	N/C	12	GND/CASE *
3	N/C	13	V <sub>CC</sub>
4	N/C	14	N/C
5	N/C	15	GND/CASE *
6	N/C	16	N/C
7	N/C	17	N/C
8	N/C	18	N/C
9	N/C	19	N/C
10	GND/CASE	20	N/C

\* Additional optional Ground connections are included only when microcircuit used is 54AC00 (see paragraph 3.3.3.1), and may be connected to circuit ground plane for minimum overshoot/ringing when driving capacitive loads.

**FIGURE 1. PACKAGE DIMENSIONS AND TERMINAL CONNECTIONS**