

DO NOT SCALE FROM THIS PRINT

QSS-XXX-01-XXX-D-DP-RA-WT-XXX

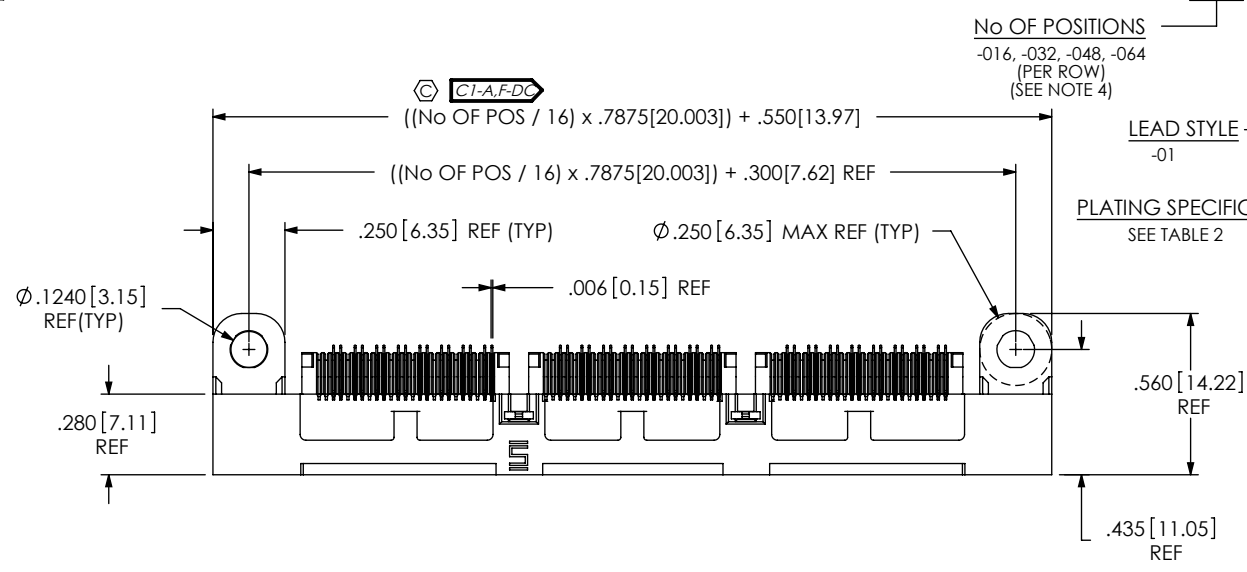

- OPTION**
- LS1: LOCKING SCREW (SEE FIG. 2, SHT 3) (FOR MATING WITH QTS-...-RA-..LS1)
 - SP: SOLDER PIN (NOT AVAILABLE W/ LS1 OPTION) (USE SP-19-T) SEE FIG. 3, SHT 4)
 - K: KAPTON PAD (SEE FIG 4, SHT 4) (USE K-500-300)
 - WT: WELD TAB (SEE NOTE 4) (USE WT-16-XX-T)
 - RA: RIGHT ANGLE
 - DP: DIFFERENTIAL PAIR
- ROW SPECIFICATION**
- D: DOUBLE (USE QSS-25-01-D-XX-RA)

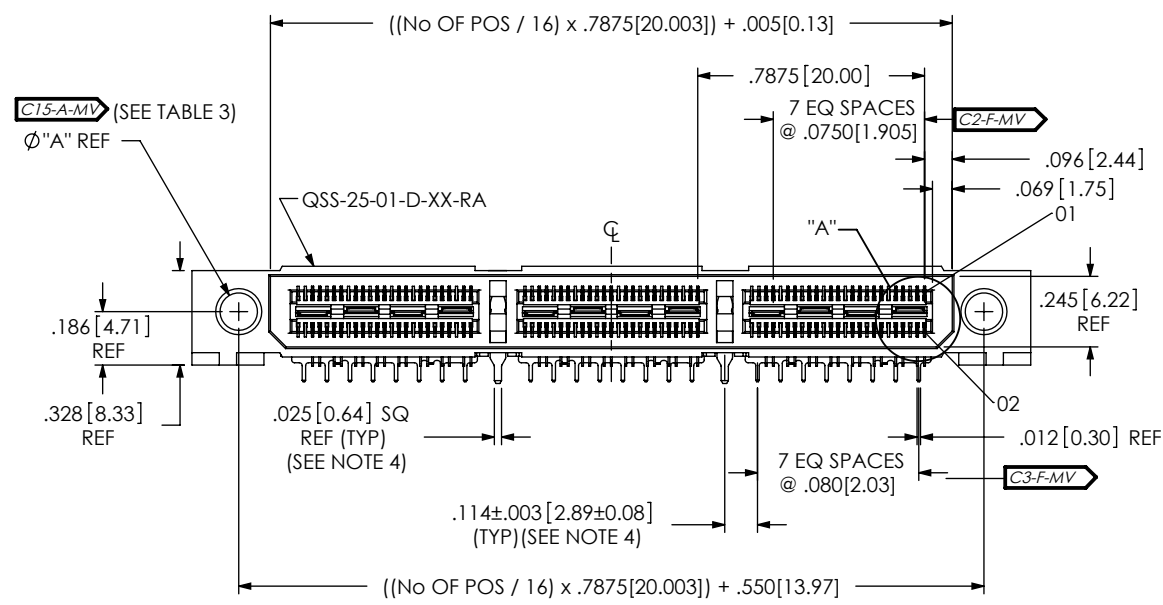
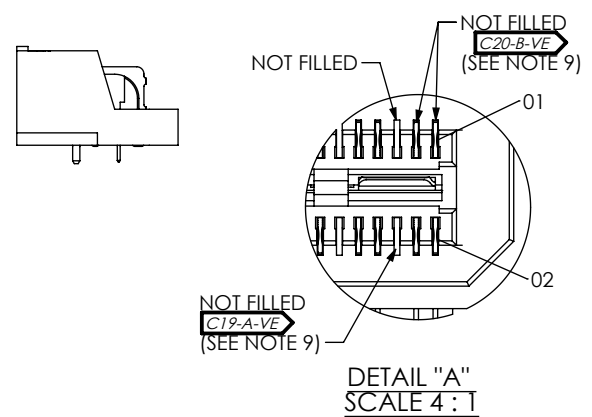
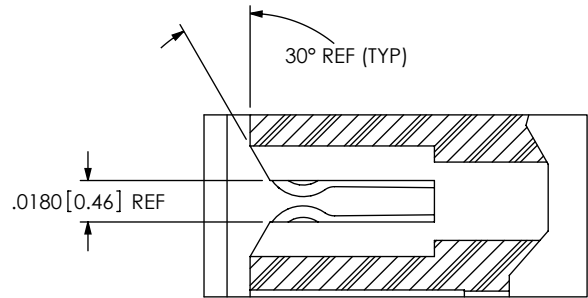
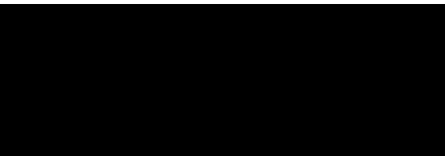
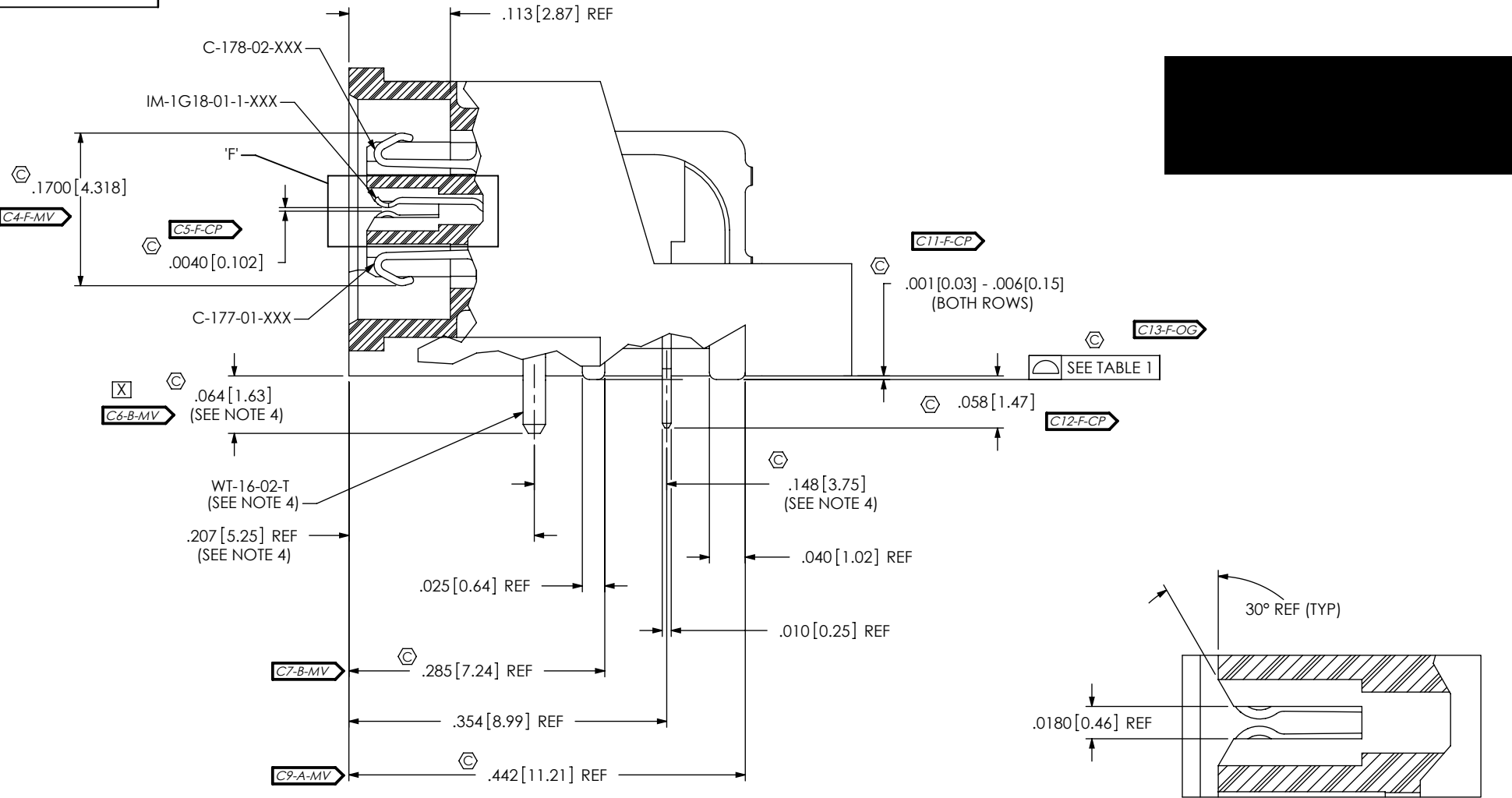

FIG. 1
QSS-048-01-XXX-D-DP-RA SHOWN



- NOTES:
1. Ⓢ REPRESENTS A CRITICAL DIMENSION.
 2. BURR ALLOWANCE: .0010 MAX.
 3. MINIMUM PUSHOUT FORCE: 6 OZ.
 4. WELD TABS (WT-16-02-T) NOT AVAILABLE ON -016 POSITION.
 5. IF NEEDED, -L PLATING CAN BE SUBSTITUTED FOR -F PLATING.
 6. IM-1G18-01-1-XX RETENTION TO BE 1.0 LBS. MINIMUM PRIOR TO SECOND ROW FILL.
 7. DESIGNED FOR USE WITH AT .062 THICK PCB
 8. ASSEMBLIES TO BE PACKAGED IN TRAYS.
 9. CRITICAL REFERS TO FILL / NOT FILLED PATTERN.
 10. DELETE

<p>UNLESS OTHERWISE SPECIFIED, DIMENSIONS ARE IN INCHES. TOLERANCES ARE:</p> <table border="0"> <tr> <td>DECIMALS</td> <td>ANGLES</td> </tr> <tr> <td>.XX: ±.01 [.3]</td> <td>2°</td> </tr> <tr> <td>.XXX: ±.005 [.13]</td> <td></td> </tr> <tr> <td>.XXXX: ±.0020 [.051]</td> <td></td> </tr> </table>	DECIMALS	ANGLES	.XX: ±.01 [.3]	2°	.XXX: ±.005 [.13]		.XXXX: ±.0020 [.051]		<p>PROPRIETARY NOTE THIS DOCUMENT CONTAINS INFORMATION CONFIDENTIAL AND PROPRIETARY TO SAMTEC, INC. AND SHALL NOT BE REPRODUCED OR TRANSFERRED TO OTHER DOCUMENTS OR DISCLOSED TO OTHERS OR USED FOR ANY PURPOSE OTHER THAN THAT WHICH IT WAS OBTAINED WITHOUT THE EXPRESSED WRITTEN CONSENT OF SAMTEC, INC.</p>	<p>520 PARK EAST BLVD, NEW ALBANY, IN 47150 PHONE: 812-944-6733 FAX: 812-948-5047 e-Mail info@SAMTEC.com code 55322</p>
	DECIMALS	ANGLES								
.XX: ±.01 [.3]	2°									
.XXX: ±.005 [.13]										
.XXXX: ±.0020 [.051]										
<p>MATERIAL: DO NOT SCALE DRAWING SHEET SCALE: 1:0.6666666666666667</p> <p>INSULATOR: LCP, COLOR: BLACK</p> <p>TERMINAL, GROUND PLANE & WELD TAB: PHOS BRONZE</p>	<p>DESCRIPTION: .635mm DOUBLE ROW DIFFERENTIAL PAIR RA SOCKET STRIP</p> <p>DWG. NO. QSS-XXX-01-XXX-D-DP-RA-WT-XXX</p> <p>BY: KEVIN B 02/26/04 SHEET 1 OF 4</p>									



DETAIL 'F'
SCALE 12 : 1

F:\DWG\MISC\MKTG\QSS-XXX-01-XXX-D-DP-RA-WT-XXX-MKT.SLDDRW

PROPRIETARY NOTE

THIS DOCUMENT CONTAINS INFORMATION CONFIDENTIAL AND PROPRIETARY TO SAMTEC, INC. AND SHALL NOT BE REPRODUCED OR TRANSFERRED TO OTHER DOCUMENTS OR DISCLOSED TO OTHERS OR USED FOR ANY PURPOSE OTHER THAN THAT WHICH IT WAS OBTAINED WITHOUT THE EXPRESSED WRITTEN CONSENT OF SAMTEC, INC.

DO NOT SCALE DRAWING

SHEET SCALE: 1:0.166667

520 PARK EAST BLVD, NEW ALBANY, IN 47150
PHONE: 812-944-6733 FAX: 812-948-5047
e-Mail info@SAMTEC.com code 55322

DESCRIPTION:
.635mm DOUBLE ROW DIFFERENTIAL PAIR RA SOCKET STRIP

DWG. NO.
QSS-XXX-01-XXX-D-DP-RA-WT-XXX

BY: KEVIN B 02/26/04 SHEET 2 OF 4

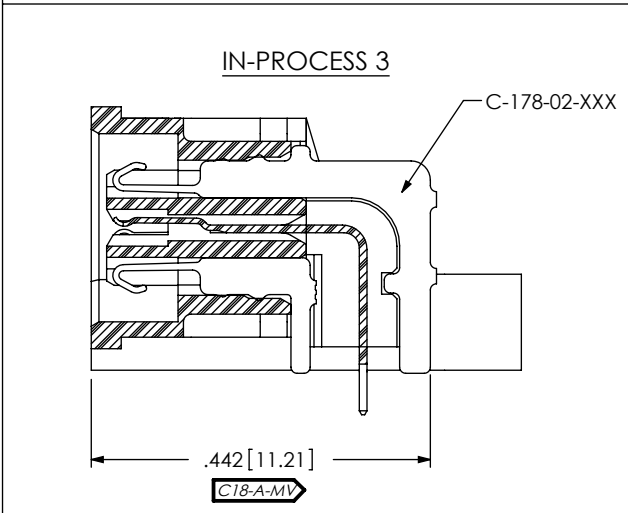
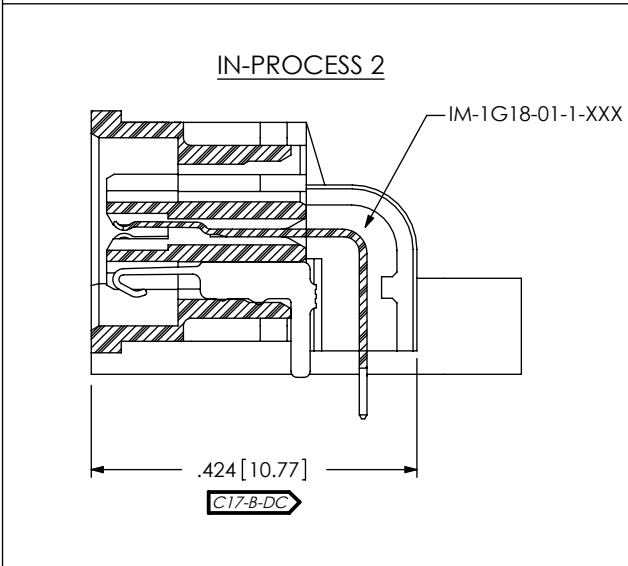
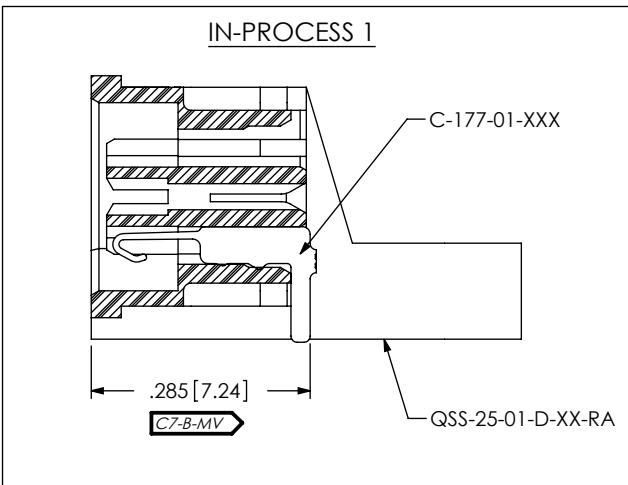
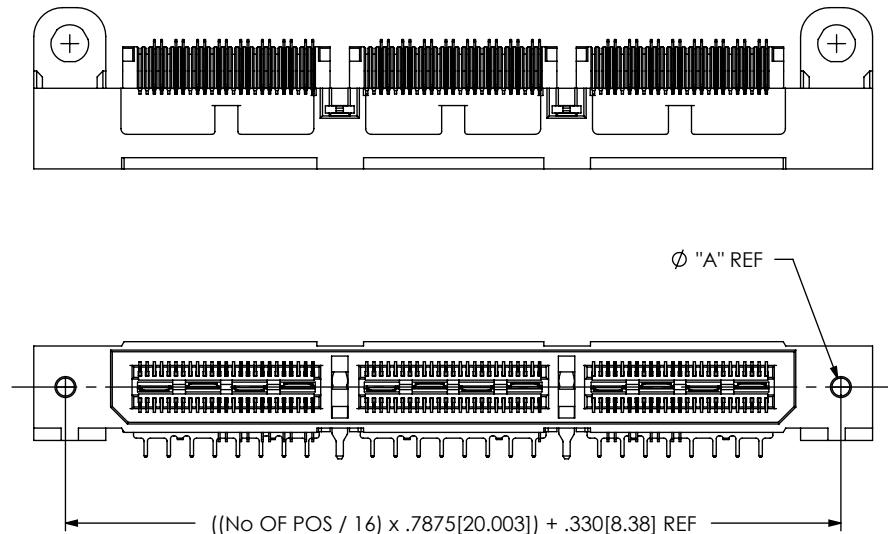

FIG. 2
QSS-048-01-XXX-D-DP-RA-LS1 SHOWN
(SAME AS FIG. 1, EXCEPT AS SHOWN)



CRITICAL DIMENSION INSPECTION INSTRUCTION TABLE		
ASSEMBLY OPERATION	START-UP INSPECTION INSPECT CODE A	IN-PROCESS INSPECTION INSPECT CODE B
FILL C-177-01-X	C1, C15, C19	C7, C20
FILL IM-1G18-XX-1-XX	C1, C7, C19, C20	C17
FILL C-178-02-X	C1, C7, C19, C20	C18
FILL WT-16-XX-T	C1, C7, C18, C19, C20	C6
LS1	C1, C18, C15	C21
SP	C1, C18	C21
K	C1, C18	C16

F:\DWG\MISC\MKTG\QSS-XXX-01-XXX-D-DP-RA-WT-XXX-MKT.SLDDRW

PROPRIETARY NOTE
THIS DOCUMENT CONTAINS INFORMATION CONFIDENTIAL AND PROPRIETARY TO SAMTEC, INC. AND SHALL NOT BE REPRODUCED OR TRANSFERRED TO OTHER DOCUMENTS OR DISCLOSED TO OTHERS OR USED FOR ANY PURPOSE OTHER THAN THAT WHICH IT WAS OBTAINED WITHOUT THE EXPRESSED WRITTEN CONSENT OF SAMTEC, INC.

DO NOT SCALE DRAWING

SHEET SCALE: 1:0.666667

520 PARK EAST BLVD, NEW ALBANY, IN 47150
PHONE: 812-944-6733 FAX: 812-948-5047
e-Mail: info@SAMTEC.com code 55322

DESCRIPTION:
.635mm DOUBLE ROW DIFFERENTIAL PAIR RA SOCKET STRIP

DWG. NO.
QSS-XXX-01-XXX-D-DP-RA-WT-XXX

BY: KEVIN B 02/26/04 SHEET 3 OF 4

FIG. 3

QSS-048-01-XXX-D-DP-RA-WT-SP SHOWN
(SAME AS FIG. 1, EXCEPT AS SHOWN)

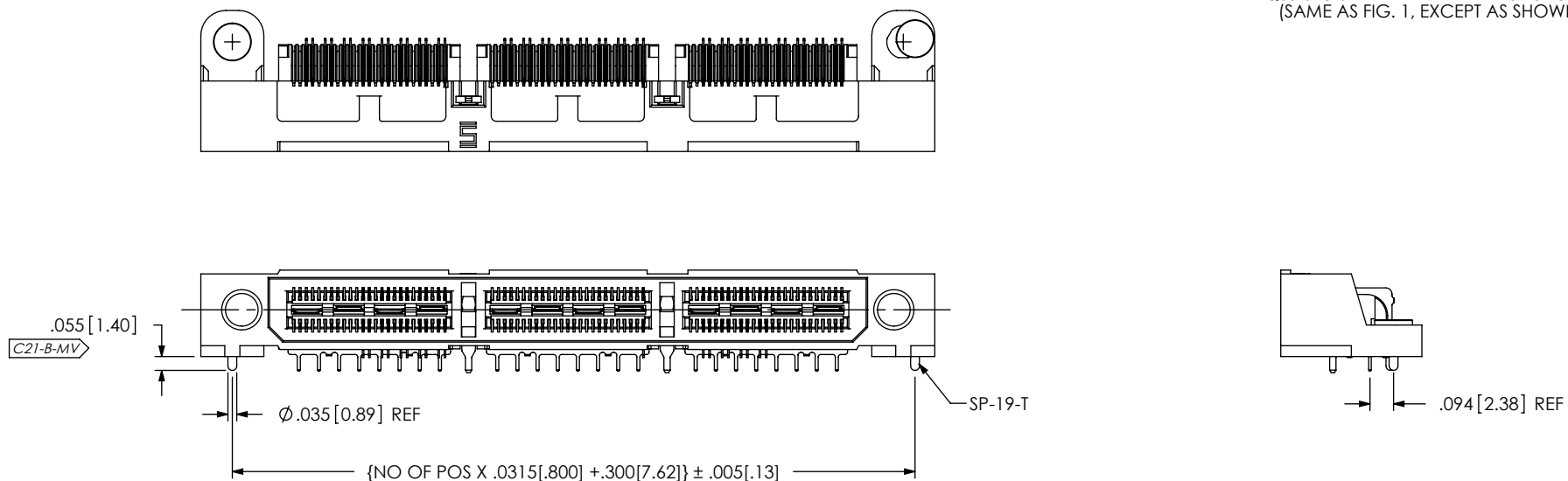
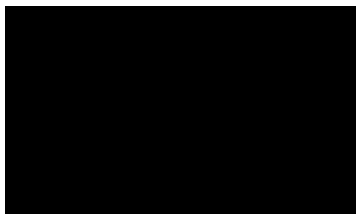
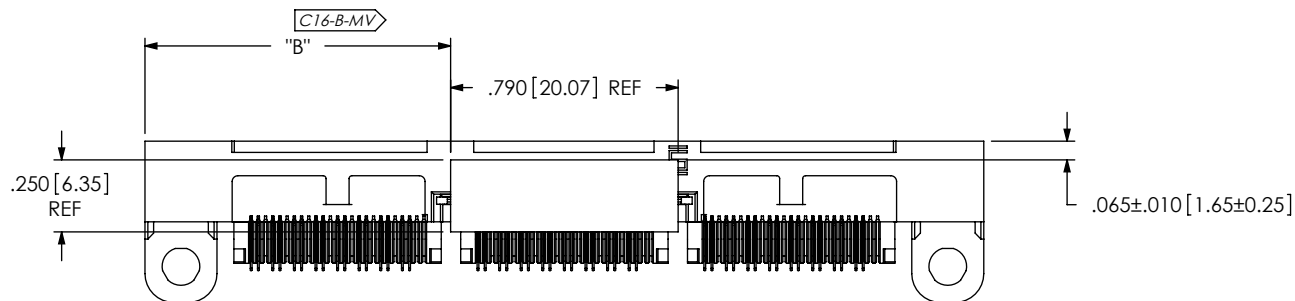

FIG. 4

QSS-048-01-XXX-D-DP-RA-WT-K SHOWN
(SAME AS FIG. 1, EXCEPT AS SHOWN)



PROPRIETARY NOTE

THIS DOCUMENT CONTAINS INFORMATION CONFIDENTIAL AND PROPRIETARY TO SAMTEC, INC. AND SHALL NOT BE REPRODUCED OR TRANSFERRED TO OTHER DOCUMENTS OR DISCLOSED TO OTHERS OR USED FOR ANY PURPOSE OTHER THAN THAT WHICH IT WAS OBTAINED WITHOUT THE EXPRESSED WRITTEN CONSENT OF SAMTEC, INC.

DO NOT SCALE DRAWING SHEET SCALE: 3:2

SHEET SCALE: 1:0.666667



520 PARK EAST BLVD, NEW ALBANY, IN 47150
PHONE: 812-944-6733 FAX: 812-948-5047
e-Mail info@SAMTEC.com code 55322

DESCRIPTION:
.635mm DOUBLE ROW DIFFERENTIAL PAIR RA SOCKET STRIP

DWG. NO.
QSS-XXX-01-XXX-D-DP-RA-WT-XXX

BY: KEVIN B 02/26/04 SHEET 4 OF 4