



M. S. KENNEDY CORP.

INVERTING OPERATIONAL AMPLIFIER 738

4707 Dey Road Liverpool, N.Y. 13088

(315) 701-6751

FEATURES:

- Very Fast Settling Time
- Very Fast Slew Rate
- Wide Bandwidth
- Low Noise
- Very Accurate (Low Offset)
- Contact MSK for MIL-PRF-38534 Qualification Status

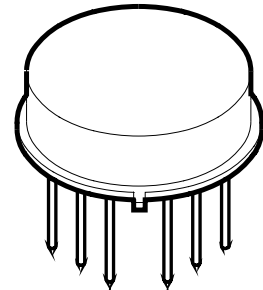

DESCRIPTION:

The MSK 738 is an inverting operational amplifier that exhibits an impressive combination of high speed and precision D.C. characteristics. The Op-amp's very fast slew rate, very fast settling time and wide bandwidth, along with its extremely low input offset voltage, offset drift and low noise, make it an outstanding performer.

EQUIVALENT SCHEMATIC

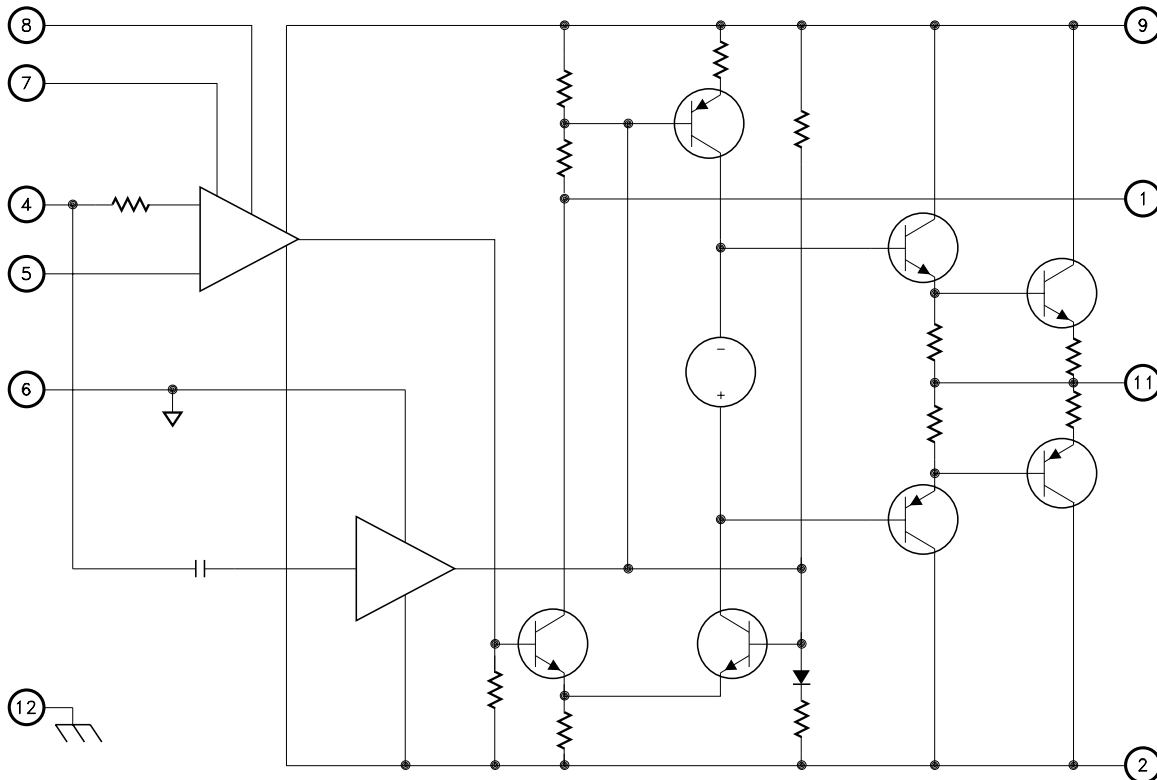

TYPICAL APPLICATIONS

- High Performance Data Acquisition
- Coaxial Line Driver
- Data Conversion Circuits
- High Speed Communications

PIN-OUT INFORMATION

- | | |
|-------------------------|-------------------------|
| 1 Compensation | 7 Balance |
| 2 Negative Power Supply | 8 Balance |
| 3 NC | 9 Positive Power Supply |
| 4 Inverting Input | 10 NC |
| 5 Non-Inverting Input | 11 Output |
| 6 Ground | 12 Case Connection |

ABSOLUTE MAXIMUM RATINGS ^⑧

$\pm V_{CC}$	Supply Voltage	+18V
I_{OUT}	Peak Output Current	$\pm 200\text{mA}$
V_{IN}	Differential Input Voltage	$\pm 12\text{V}$
T_C	Case Operating Temperature Range (MSK 738B/E)	-55°C to $+125^\circ\text{C}$
	(MSK 738)	-40°C to $+85^\circ\text{C}$

T_{ST}	Storage Temperature Range . . .	-65°C to $+150^\circ\text{C}$
T_{LD}	Lead Temperature Range	300°C (10 Seconds Soldering)
P_D	Power Dissipation	See Curve
T_J	Junction Temperature	150°C

ELECTRICAL SPECIFICATIONS

$\pm V_{CC} = \pm 15\text{V}$ Unless Otherwise Specified

Parameter	Test Conditions	Group A Subgroup	MSK 738B/E			MSK 738			Units
			Min.	Typ.	Max.	Min.	Typ.	Max.	
STATIC									
Supply Voltage Range ^②		-	± 12	± 15	± 18	± 12	± 15	± 18	V
Quiescent Current	$V_{IN} = 0\text{V}$	1	-	± 39	± 40	-	± 39	± 42	mA
	$A_v = -1\text{V/V}$	2,3	-	± 40	± 42	-	-	-	mA
Thermal Resistance ^②	Junction to Case Output Devices	-	-	46	-	-	46	-	$^\circ\text{C/W}$
INPUT									
Input Offset Voltage	Bal. Pins = NC $V_{IN} = 0\text{V}$ $A_v = -100\text{V/V}$	1	-	± 25	± 75	-	± 50	± 100	μV
Input Offset Voltage Drift ^②	$V_{IN} = 0\text{V}$	2,3	-	± 0.5	± 1	-	-	-	$\mu\text{V}/^\circ\text{C}$
Input Offset Adjust	$R_{POT} = 10\text{K}\Omega$ $T_o + V_{CC}$ $A_v = -1\text{V/V}$	1	Adjust to zero			Adjust to zero			mV
		2,3	Adjust to zero			-	-	-	mV
Input Bias Current ^⑦	$V_{CM} = 0\text{V}$	1	-	± 10	± 40	-	± 20	± 60	nA
	Either Input	2,3	-	± 20	± 80	-	-	-	nA
Input Offset Current	$V_{CM} = 0\text{V}$	1	-	2	20	-	10	30	nA
		2,3	-	5	40	-	-	-	nA
Input Impedance ^②	F = DC Differential	-	-	5	-	-	5	-	$\text{M}\Omega$
Power Supply Rejection Ratio ^②	$\Delta V_{CC} = \pm 5\text{V}$	-	-	1	10	-	2	20	$\mu\text{V/V}$
Input Noise Voltage ^②	F = 0.1Hz To 10Hz	-	-	0.15	-	-	0.2	-	μV_{p-p}
Input Noise Voltage Density ^②	F = 1KHz	-	-	3.8	-	-	4	-	$\text{nV}/\sqrt{\text{Hz}}$
Input Noise Current Density ^②	F = 1KHz	-	-	0.6	-	-	0.7	-	$\text{pA}/\sqrt{\text{Hz}}$
OUTPUT									
Output Voltage Swing	$R_L = 100\Omega$ $A_v = -3\text{V/V}$ $F \leq 20\text{MHz}$	4	± 10	± 12	-	± 10	± 11.8	-	V
Output Current	$A_v = -3\text{V/V}$ $T_J < 150^\circ\text{C}$	4	± 100	± 120	-	± 100	± 120	-	mA
Settling Time ^{① ②}	0.1% 10V step	4	-	30	40	-	35	45	nS
Full Power Bandwidth	$R_L = 100\Omega$ $V_o = \pm 10\text{V}$	4	20	22	-	15	20	-	MHz
Bandwidth (Small Signal) ^②	$R_L = 100\Omega$	4	175	200	-	165	190	-	MHz
TRANSFER CHARACTERISTICS									
Slew Rate	$V_{OUT} = \pm 10\text{V}$ $R_L = 100\Omega$ $A_v = -1.5\text{V/V}$	4	3200	3500	-	3500	3200	-	$\text{V}/\mu\text{S}$
Open Loop Voltage Gain ^②	$R_L = 1\text{K}\Omega$ F = 1KHz $V_{OUT} = \pm 10\text{V}$	4	100	110	-	95	105	-	dB

NOTES:

- ① $A_v = -1$, measured in false summing junction circuit.
- ② Guaranteed by design but not tested. Typical parameters are representative of actual device performance but are for reference only.
- ③ Industrial grade and "E" suffix devices shall be tested to subgroups 1 and 4 unless otherwise specified.
- ④ Military grade devices ("B" suffix) shall be 100% tested to subgroups 1,2,3 and 4.
- ⑤ Subgroups 5 and 6 testing available upon request.
- ⑥ Subgroup 1,4 $T_A = T_C = +25^\circ\text{C}$
Subgroup 2,5 $T_A = T_C = +125^\circ\text{C}$
Subgroup 3,6 $T_A = T_C = -55^\circ\text{C}$
- ⑦ Measurement taken 0.5 seconds after application of power using automatic test equipment.
- ⑧ Continuous operation at or above absolute maximum ratings may adversely effect the device performance and/or life cycle.

APPLICATION NOTES

HEAT SINKING

To determine if a heat sink is necessary for your application and if so, what type, refer to the thermal model and governing equation below.

Thermal Model:

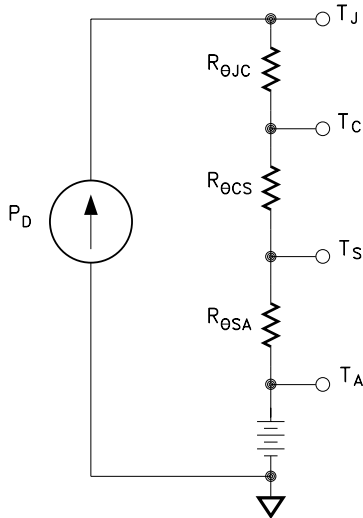

Governing Equation:

$$T_J = P_D \times (R_{\theta JC} + R_{\theta CS} + R_{\theta SA}) + T_A$$

Where

T_J = Junction Temperature

P_D = Total Power Dissipation

$R_{\theta JC}$ = Junction to Case Thermal Resistance

$R_{\theta CS}$ = Case to Heat Sink Thermal Resistance

$R_{\theta SA}$ = Heat Sink to Ambient Thermal Resistance

T_C = Case Temperature

T_A = Ambient Temperature

T_S = Sink Temperature

Example:

This example demonstrates a worst case analysis for the op-amp output stage. This occurs when the output voltage is 1/2 the power supply voltage. Under this condition, maximum power transfer occurs and the output is under maximum stress.

Conditions:

$V_{CC} = \pm 16VDC$

$V_O = \pm 8Vp$ Sine Wave, Freq. = 1KHz

$R_L = 100\Omega$

For a worst case analysis we will treat the +8Vp sine wave as an 8VDC output voltage.

1.) Find Driver Power Dissipation

$$\begin{aligned} P_D &= (V_{CC} - V_O) (V_O / R_L) \\ &= (16V - 8V) (8V / 100\Omega) \\ &= 0.64W \end{aligned}$$

2.) For conservative design, set $T_J = +125^\circ C$

3.) For this example, worst case $T_A = +90^\circ C$

4.) $R_{\theta JC} = 46^\circ C/W$ from MSK 738B Data Sheet

5.) $R_{\theta CS} = 0.15^\circ C/W$ for most thermal greases

6.) Rearrange governing equation to solve for $R_{\theta SA}$

$$\begin{aligned} R_{\theta SA} &= ((T_J - T_A) / P_D) - (R_{\theta JC}) - (R_{\theta CS}) \\ &= ((125^\circ C - 90^\circ C) / 0.64W) - 45^\circ C/W - 0.15^\circ C/W \\ &= 54.7 - 46.15 \\ &= 8.5^\circ C/W \end{aligned}$$

The heat sink in this example must have a thermal resistance of no more than $8.5^\circ C/W$ to maintain a junction temperature of no more than $+125^\circ C$.

OFFSET NULL

Typically, the MSK 738(B) has an input offset voltage of less than $\pm 25\mu V$. If it is desirable to adjust the offset closer to "zero", or to a value other than "zero", the circuit below is recommended. R_P should be a ten-turn $10K\Omega$ potentiometer. Typical offset adjust is $\pm 5mV$.

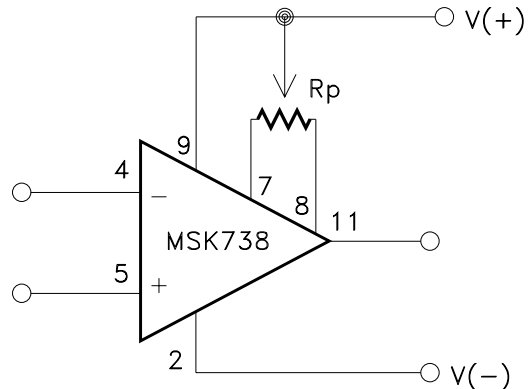

Potentiometer values ranging from $1K\Omega$ to $1M\Omega$ can be used with only a small amount of degradation (typically 0.15 to $0.25\mu V/^\circ C$) of input offset voltage drift. If the input offset voltage is to be trimmed to a value other than "zero", the following formula can be used to approximate the change in input offset voltage drift:

$$\Delta V_{OSD} = V_{OS} (\text{trimmed}) / 250$$

Recommended External Component Selection Guide

APPROXIMATE DESIRED GAIN	$R_i(+)$	$R_i(-)$	$R_f(\text{Ext})$	C_f	C_1
① -1	499Ω	$1K\Omega$	$1K\Omega$	②	$1\mu f$
① -2	330Ω	499Ω	$1K\Omega$	②	$1\mu f$
① -5	169Ω	200Ω	$1K\Omega$	②	$1\mu f$
① -8	100Ω	124Ω	$1K\Omega$	②	$1\mu f$
① -10	90.9Ω	100Ω	$1K\Omega$	②	$1\mu f$
① -20	100Ω	100Ω	$2K\Omega$	②	$1\mu f$

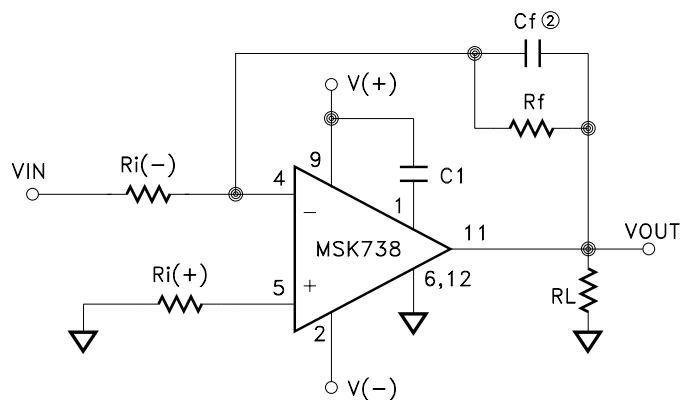

- ① The positive input resistor is selected to minimize any bias current induced offset voltage.
- ② The feedback capacitor will help compensate for stray input capacitance. The value of this capacitor can be dependent on individual applications. A 2 to 9 pf capacitor is usually optimum for most applications.

TYPICAL PERFORMANCE CURVES

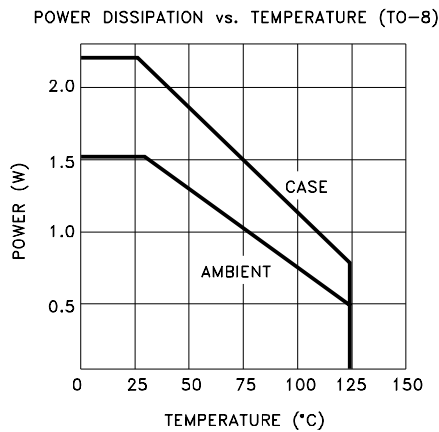
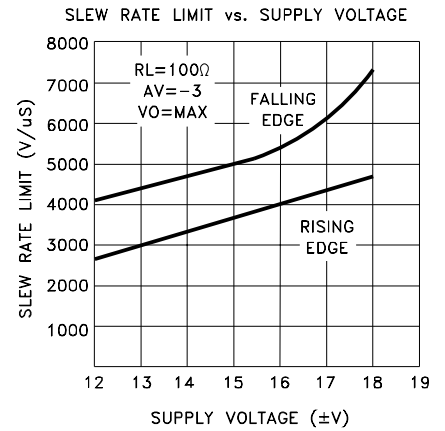
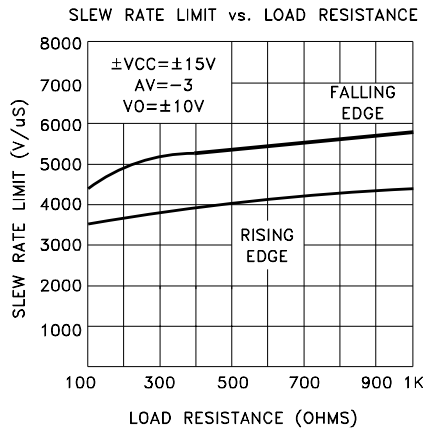
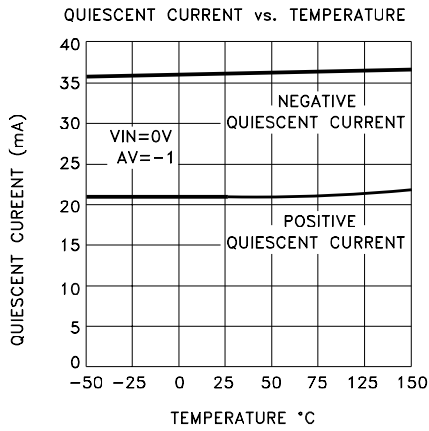
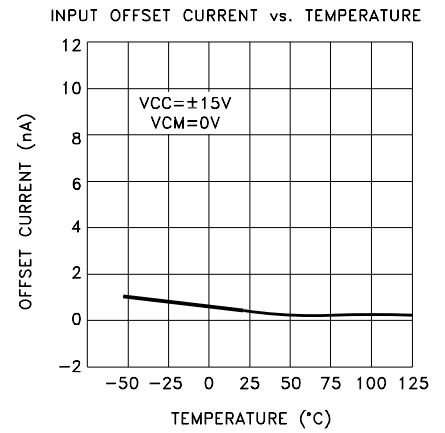
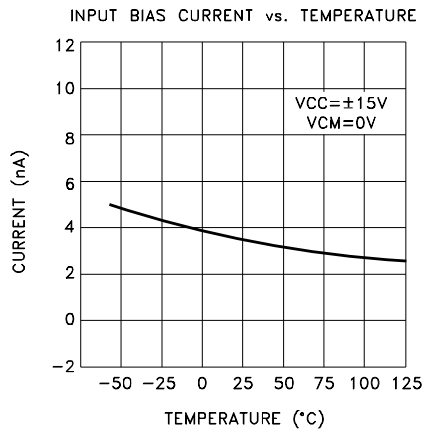
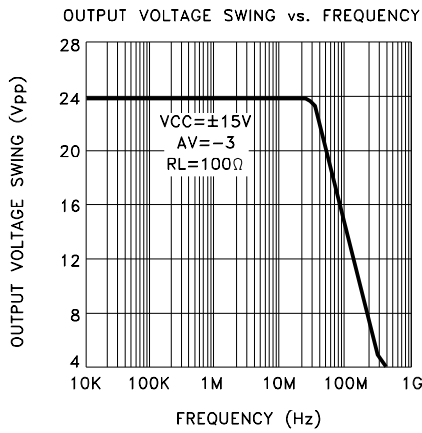
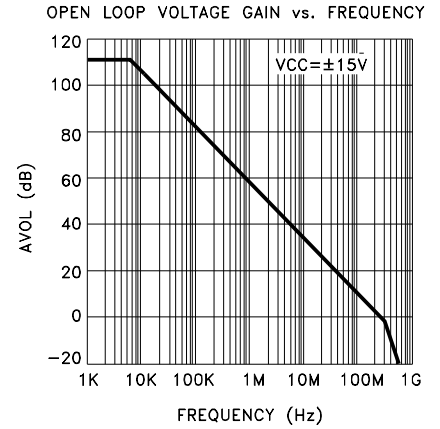
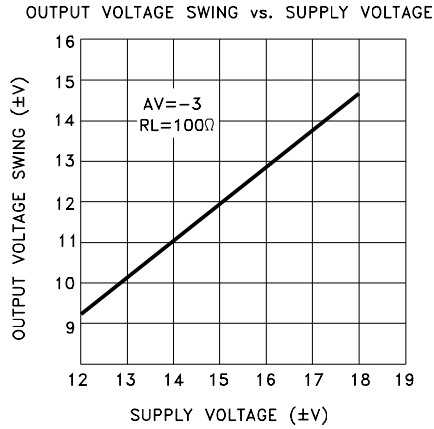
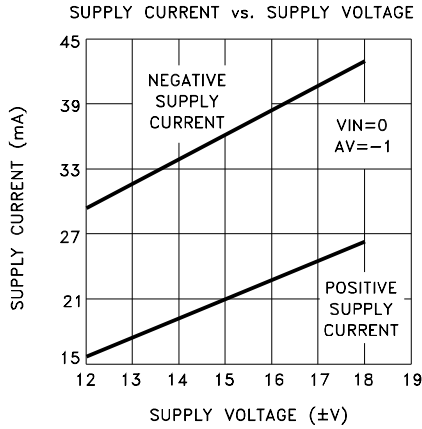

MECHANICAL SPECIFICATIONS

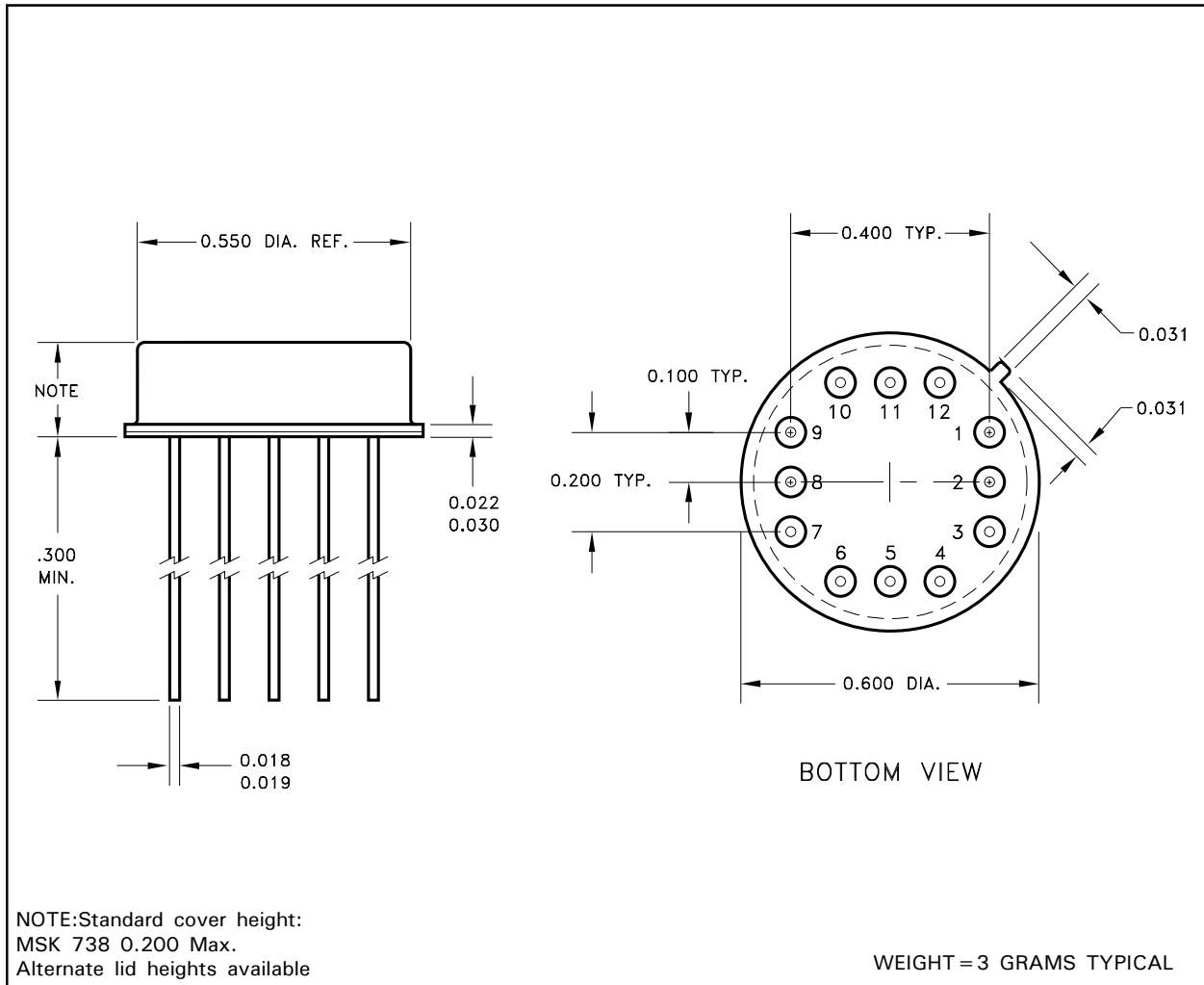

NOTE: ALL DIMENSIONS ARE ± 0.010 INCHES UNLESS OTHERWISE LABELED.

ORDERING INFORMATION

MSK738 B

SCREENING

BLANK = INDUSTRIAL; B = MIL-PRF-38534 CLASS H

E = EXTENDED RELIABILITY

GENERAL PART NUMBER

M.S. Kennedy Corp.
 4707 Dey Road, Liverpool, New York 13088
 Phone (315) 701-6751
 FAX (315) 701-6752
 www.mskennedy.com

The information contained herein is believed to be accurate at the time of printing. MSK reserves the right to make changes to its products or specifications without notice, however, and assumes no liability for the use of its products. Please visit our website for the most recent revision of this datasheet. Contact MSK for MIL-PRF-38534 qualification status.