

Customer Information Sheet

DRAWING No.: M80-960

IF IN DOUBT - ASK

©

NOT TO SCALE

THIRD ANGLE PROJECTION

ALL DIMENSIONS IN mm

CABLE ASSEMBLIES WILL BE ALLOATED CUSTOMER SPECIAL PART NUMBERS

NOTES:

- ALL TOLERANCES ARE ± 0.25 UNLESS OTHERWISE STATED.
- CABLE ASSEMBLY SPECIFICATION:
CONNECTOR = M80-888XX05 (POLYESTER) OR M80-844XX05 (POLYAMIDE 46) (XX = No. OF WAYS)
WIRE = 24 TO 28 AWG PTFE EQUIPMENT WIRE TO BS3G210 TYPE A
SLEEVE = HELLERMANN TYTON 'HELSSYN' SLEEVE, BLACK POLYCHLOROPRENE RUBBER, UL94V-0.
- ARROW INDICATES POLARISATION SIDE.

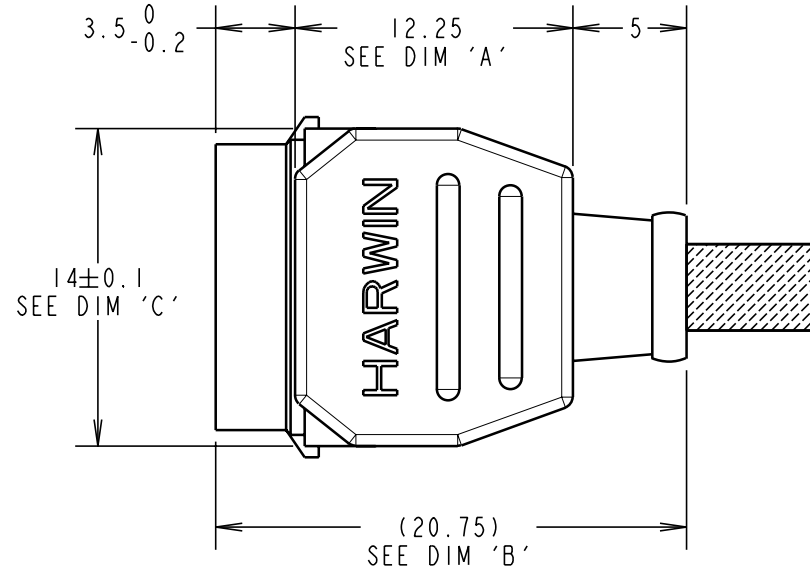
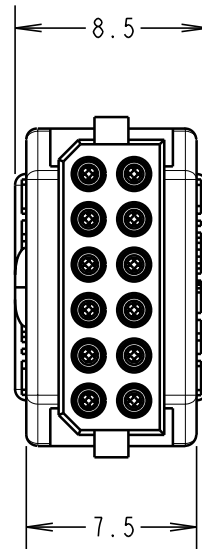

SCALE 2

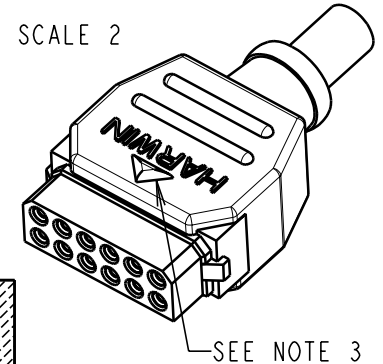

No. OF WAYS	DIM 'A'	DIM 'B'	DIM 'C'
4 (2+2)	12.25	(20.75)	6 \pm 0.1
6 (3+3)	12.25	(20.75)	8 \pm 0.1
8 (4+4)	12.25	(20.75)	10 \pm 0.1
10 (5+5)	12.25	(20.75)	12 \pm 0.1
12 (6+6)	12.25	(20.75)	14 \pm 0.1
14 (7+7)	12.25	(20.75)	16 \pm 0.1
16 (8+8)	15.25	(23.75)	18 \pm 0.1
18 (9+9)	15.25	(23.75)	20 \pm 0.1
20 (10+10)	15.25	(23.75)	22 \pm 0.1
26 (13+13)	17.25	(25.75)	28 \pm 0.1
34 (17+17)	20.25	(28.75)	36 \pm 0.1

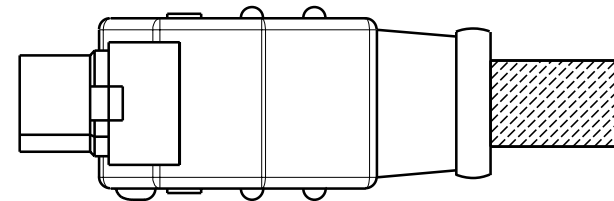

3	24.10.00	5514
ISS.	DATE	C/NOTE
APPROVED:		
CHECKED:		
DRAWN: W. J. BOURNE		
CUSTOMER REF.:		
ASSEMBLY DRG:		

HARWIN

THIS DRAWING AND ANY INFORMATION OR DESCRIPTIVE MATTER SET OUT HEREON ARE CONFIDENTIAL AND COPYRIGHT PROPERTY OF THE HARWIN GROUP AND MUST NOT BE DISCLOSED, LOANED, COPIED OR USED FOR MANUFACTURING, TENDERING OR FOR ANY OTHER PURPOSE WITHOUT THEIR WRITTEN PERMISSION.

TOLERANCES

~~ALL DIMENSIONS~~
 ~~± 0.10 mm~~

ANGLES = $\pm 5^\circ$

UNLESS STATED

MATERIAL:

NYLON 6 UNFILLED
UL94V-0, BLACK

FINISH:

S/AREA:

mm²

TITLE:

DATAMATE DIL CRIMP
SOCKET OVERMouldING

DRAWING NUMBER:

M80-960

SHT
1 OF 1

HARWIN INC
U.S.A.

TEL: (812) 285 0055
FAX: (812) 285 0056

HARWIN PLC
U.K.

TEL: 023 9237 0451
FAX: 023 9231 4590

HARWIN PTE
SINGAPORE

TEL: 65 7794909
FAX: 65 7793868