

8-CHANNEL ANALOG MULTIPLEXER/DEMULTIPLEXER WITH LATCH

FEATURES

- Wide analog input voltage range: $\pm 5\text{ V}$
- Low "ON" resistance:
80 Ω (typ.) at $V_{CC} - V_{EE} = 4.5\text{ V}$
70 Ω (typ.) at $V_{CC} - V_{EE} = 6.0\text{ V}$
60 Ω (typ.) at $V_{CC} - V_{EE} = 9.0\text{ V}$
- Logic level translation:
to enable 5 V logic to communicate with $\pm 5\text{ V}$ analog signals
- Typical "break before make" built in
- Address latches provided
- Output capability: non-standard
- I_{CC} category: MSI

GENERAL DESCRIPTION

The 74HC/HCT4351 are high-speed Si-gate CMOS devices. They are specified in compliance with JEDEC standard no. 7A.

The 74HC/HCT4351 are 8-channel analog multiplexers/demultiplexers with three select inputs (S_0 to S_2), two enable inputs (\bar{E}_1 and E_2), a latch enable input ($\bar{L}\bar{E}$), eight independent inputs/outputs (Y_0 to Y_7) and a common input/output (Z).

With \bar{E}_1 LOW and E_2 is HIGH, one of the eight switches is selected (low impedance ON-state) by S_0 to S_2 . The data at the select inputs may be latched by using the active LOW latch enable input ($\bar{L}\bar{E}$). When $\bar{L}\bar{E}$ is HIGH the latch is transparent. When either of the two enable inputs, \bar{E}_1 (active LOW) and E_2 (active HIGH), is inactive, all 8 analog switches are turned off.

(continued on next page)

SYMBOL	PARAMETER	CONDITIONS	TYPICAL		UNIT
			HC	HCT	
t_{PZH}/t_{PZL}	turn "ON" time \bar{E}_1, E_2 or S_N to V_{OS}	$C_L = 15\text{ pF}$ $R_L = 1\text{ k}\Omega$ $V_{CC} = 5\text{ V}$	27	35	ns
t_{PHZ}/t_{PLZ}	turn "OFF" time \bar{E}_1, E_2 or S_N to V_{OS}		21	23	ns
C_I	input capacitance		3.5	3.5	pF
C_{PD}	power dissipation capacitance per switch	notes 1 and 2	25	25	pF
C_S	max. switch capacitance independent (Y) common (Z)		5	5	pF
			25	25	pF

$V_{EE} = \text{GND} = 0\text{ V}$; $T_{amb} = 25\text{ }^\circ\text{C}$; $t_r = t_f = 6\text{ ns}$

Notes

1. C_{PD} is used to determine the dynamic power dissipation (P_D in μW):

$$P_D = C_{PD} \times V_{CC}^2 \times f_i + \sum \{ (C_L + C_S) \times V_{CC}^2 \times f_o \}$$

f_i = input frequency in MHz
 f_o = output frequency in MHz
 $\sum \{ (C_L + C_S) \times V_{CC}^2 \times f_o \}$ = sum of outputs
 C_L = output load capacitance in pF
 C_S = max. switch capacitance in pF
 V_{CC} = supply voltage in V

2. For HC the condition is $V_I = \text{GND}$ to V_{CC}
For HCT the condition is $V_I = \text{GND}$ to $V_{CC} - 1.5\text{ V}$

PACKAGE OUTLINES

20-lead DIL; plastic (SOT146).
20-lead mini-pack; plastic (SO20; SOT163A).

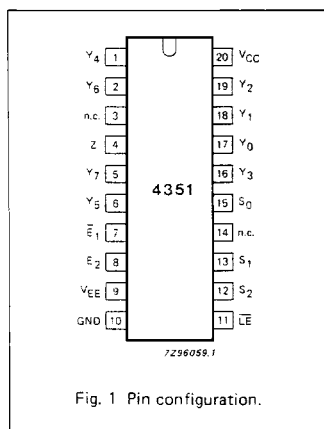

Fig. 1 Pin configuration.

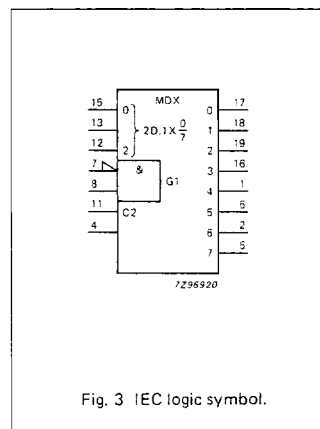
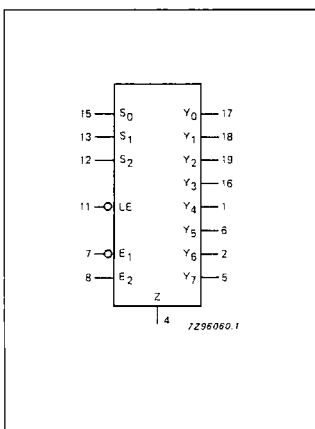

Fig. 3 IEC logic symbol.

PIN DESCRIPTION

PIN NO.	SYMBOL	NAME AND FUNCTION
4	Z	common
3, 14	n.c.	not connected
7	\bar{E}_1	enable input (active LOW)
8	E_2	enable input (active HIGH)
9	V_{EE}	negative supply voltage
10	GND	ground (0 V)
11	\bar{LE}	latch enable input (active LOW)
15, 13, 12	S_0 to S_2	select inputs
17, 18, 19, 16, 1, 6, 2, 5	Y_0 to Y_7	independent inputs/outputs
20	V_{CC}	positive supply voltage

GENERAL DESCRIPTION

V_{CC} and GND are the supply voltage pins for the digital control inputs (S_0 to S_2 , \bar{LE} , E_1 and E_2). The V_{CC} to GND ranges are 2.0 to 10.0 V for HC and 4.5 to 5.5 V for HCT. The analog inputs/outputs (Y_0 to Y_7 , and Z) can swing between V_{CC} as a positive limit and V_{EE} as a negative limit. $V_{CC} - V_{EE}$ may not exceed 10.0 V.

For operation as a digital multiplexer/demultiplexer, V_{EE} is connected to GND (typically ground).

FUNCTION TABLE

INPUTS						CHANNEL ON
\bar{E}_1	E_2	\bar{LE}	S_2	S_1	S_0	
H	X	X	X	X	X	none
X	L	X	X	X	X	none
L	H	H	L	L	L	Y_0
L	H	H	L	L	H	Y_1
L	H	H	L	H	L	Y_2
L	H	H	L	H	H	Y_3
L	H	H	H	L	L	Y_4
L	H	H	H	L	H	Y_5
L	H	H	H	H	L	Y_6
L	H	H	H	H	H	Y_7
L	H	L	X	X	X	*
X	X	↓	X	X	X	**

H = HIGH voltage level

L = LOW voltage level

X = don't care

↓ = HIGH-to-LOW \bar{LE} transition

* Last selected channel "ON".

** Selected channels latched.

APPLICATIONS

- Analog multiplexing and demultiplexing
- Digital multiplexing and demultiplexing
- Signal gating

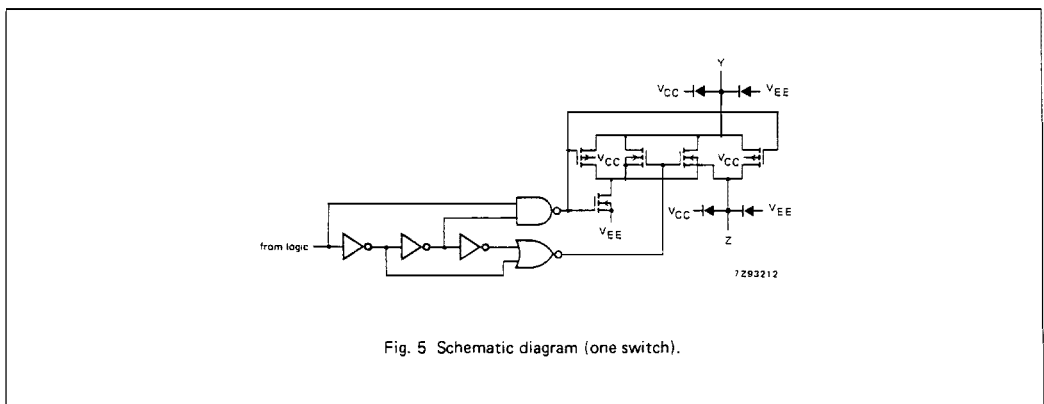
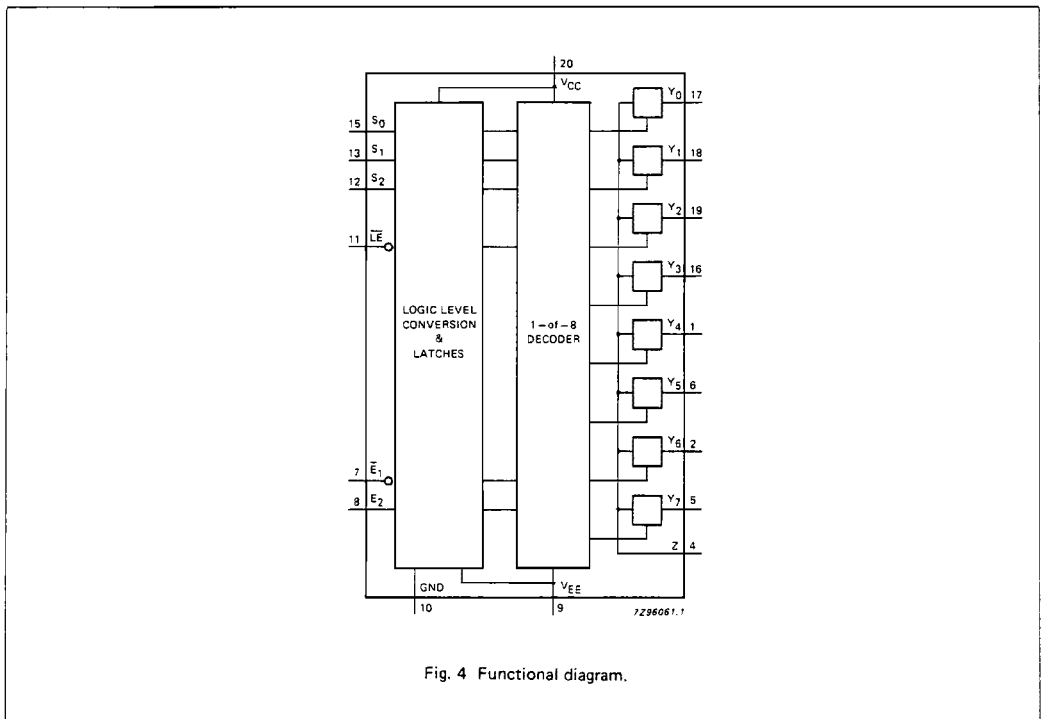

RATINGS

Limiting values in accordance with the Absolute Maximum System (IEC 134)

Voltages are referenced to $V_{EE} = \text{GND}$ (ground = 0 V)

SYMBOL	PARAMETER	MIN.	MAX.	UNIT	CONDITIONS
V_{CC}	DC supply voltage	-0.5	+11.0	V	
$\pm I_{IK}$	DC digital input diode current		20	mA	for $V_I < -0.5 \text{ V}$ or $V_I > V_{CC} + 0.5 \text{ V}$
$\pm I_{SK}$	DC switch diode current		20	mA	for $V_S < -0.5 \text{ V}$ or $V_S > V_{CC} + 0.5 \text{ V}$
$\pm I_S$	DC switch current		25	mA	for $-0.5 \text{ V} < V_S < V_{CC} + 0.5 \text{ V}$
$\pm I_{EE}$	DC V_{EE} current		20	mA	
$\pm I_{CC}$; $\pm I_{GND}$	DC V_{CC} or GND current		50	mA	
T_{stg}	storage temperature range	-65	+150	$^{\circ}\text{C}$	
P_{tot}	power dissipation per package				for temperature range: -40 to +125 $^{\circ}\text{C}$ 74HC/HCT
	plastic DIL		750	mW	above +70 $^{\circ}\text{C}$: derate linearly with 12 mW/K
	plastic mini-pack (SO)		500	mW	above +70 $^{\circ}\text{C}$: derate linearly with 8 mW/K
P_S	power dissipation per switch		100	mW	

Note to ratings

To avoid drawing V_{CC} current out of terminal Z, when switch current flows in terminals Y_n , the voltage drop across the bidirectional switch must not exceed 0.4 V. If the switch current flows into terminal Z, no V_{CC} current will flow out of terminals Y_n . In this case there is no limit for the voltage drop across the switch, but the voltages at Y_n and Z may not exceed V_{CC} or V_{EE} .

RECOMMENDED OPERATING CONDITIONS

SYMBOL	PARAMETER	74HC			74HCT			UNIT	CONDITIONS
		min.	typ.	max.	min.	typ.	max.		
V_{CC}	DC supply voltage $V_{CC}-\text{GND}$	2.0	5.0	10.0	4.5	5.0	5.5	V	see Figs 6 and 7
V_{CC}	DC supply voltage $V_{CC}-V_{EE}$	2.0	5.0	10.0	2.0	5.0	10.0	V	see Figs 6 and 7
V_I	DC input voltage range	GND		V_{CC}	GND		V_{CC}	V	
V_S	DC switch voltage range	V_{EE}		V_{CC}	V_{EE}		V_{CC}	V	
T_{amb}	operating ambient temperature range	-40		+85	-40		+85	$^{\circ}\text{C}$	see DC and AC CHARACTERISTICS
T_{amb}	operating ambient temperature range	-40		+125	-40		+125	$^{\circ}\text{C}$	
t_r, t_f	input rise and fall times		6.0	1000 500 400 250		6.0	500	ns	$V_{CC} = 2.0 \text{ V}$ $V_{CC} = 4.5 \text{ V}$ $V_{CC} = 6.0 \text{ V}$ $V_{CC} = 10.0 \text{ V}$

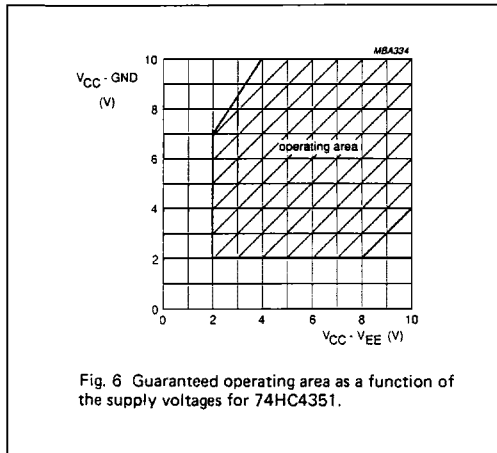

Fig. 6 Guaranteed operating area as a function of the supply voltages for 74HC4351.

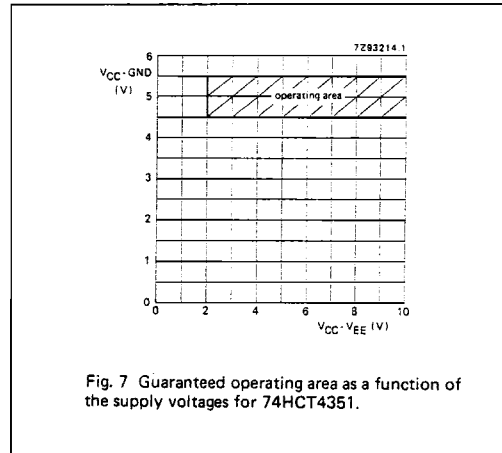

Fig. 7 Guaranteed operating area as a function of the supply voltages for 74HCT4351.

DC CHARACTERISTICS FOR 74HC/HCT

For 74HC: $V_{CC} - GND$ or $V_{CC} - V_{EE} = 2.0, 4.5, 6.0$ and 9.0 V

For 74HCT: $V_{CC} - GND = 4.5$ and 5.5 V; $V_{CC} - V_{EE} = 2.0, 4.5, 6.0$ and 9.0 V

SYMBOL	PARAMETER	T_{amb} (°C)						UNIT	TEST CONDITIONS				
		74HC/HCT							V_{CC} V	V_{EE} V	I_S μA	V_{is}	V_I
		+25		-40 to +85		-40 to +125							
		min.	typ.	max.	min.	max.	min.		max.				
R_{ON}	ON resistance (rail)	—	—	—	—	—	—	Ω	2.0	0	100	V_{CC} to V_{EE}	V_{IH} or V_{IL}
		100	180	225	270	240	195	Ω	4.5	0	1000		
		90	160	200	240	180	150	Ω	6.0	0	1000		
R_{ON}	ON resistance (rail)	70	130	165	195	180	160	Ω	4.5	-4.5	1000	V_{EE}	V_{IH} or V_{IL}
		150	—	—	—	—	—	Ω	2.0	0	100		
		80	140	175	210	180	160	Ω	4.5	0	1000		
R_{ON}	ON resistance (rail)	70	120	150	180	180	160	Ω	6.0	0	1000	V_{CC}	V_{IH} or V_{IL}
		60	105	130	160	160	160	Ω	4.5	-4.5	1000		
		150	—	—	—	—	—	Ω	2.0	0	100		
R_{ON}	ON resistance (rail)	90	160	200	240	210	180	Ω	4.5	0	1000	V_{CC}	V_{IH} or V_{IL}
		80	140	175	210	180	160	Ω	6.0	0	1000		
		65	120	150	180	180	160	Ω	4.5	-4.5	1000		
ΔR_{ON}	maximum ΔR_{ON} resistance between any two channels	—	—	—	—	—	—	Ω	2.0	0	—	V_{CC} to V_{EE}	V_{IH} or V_{IL}
		9	—	—	—	—	—	Ω	4.5	0	—		
		8	—	—	—	—	—	Ω	6.0	0	—		
		6	—	—	—	—	—	Ω	4.5	-4.5	—		

Notes to DC characteristics

- At supply voltages ($V_{CC} - V_{EE}$) approaching 2.0 V the analog switch ON-resistance becomes extremely non-linear. There it is recommended that these devices be used to transmit digital signals only, when using these supply voltages.
- For test circuit measuring R_{ON} see Fig. 8.

DC CHARACTERISTICS FOR 74HC

Voltages are referenced to GND (ground = 0 V)

SYMBOL	PARAMETER	T _{amb} (°C)								UNIT	TEST CONDITIONS			
		74HC									V _{CC} V	V _{EE} V	V _I	OTHER
		+25			-40 to +85		-40 to +125							
		min.	typ.	max.	min.	max.	min.	max.						
V _{IH}	HIGH level input voltage	1.5 3.15 4.2 6.3	1.2 2.4 3.2 4.7		1.5 3.15 4.2 6.3		1.5 3.15 4.2 6.3		V	2.0 4.5 6.0 9.0				
V _{IL}	LOW level input voltage		0.8 2.1 2.8 4.3	0.5 1.35 1.8 2.7		0.5 1.35 1.8 2.7		0.5 1.35 1.8 2.7	V	2.0 4.5 6.0 9.0				
±I _I	input leakage current			0.1 0.2		1.0 2.0		1.0 2.0	μA	6.0 10.0	0 0	V _{CC} or GND		
±I _S	analog switch OFF-state current per channel			0.1		1.0		1.0	μA	10.0	0	V _{IH} or V _{IL}	V _S = V _{CC} - V _{EE} (see Fig. 10)	
±I _S	analog switch OFF-state current all channels			0.4		4.0		4.0	μA	10.0	0	V _{IH} or V _{IL}	V _S = V _{CC} - V _{EE} (see Fig. 10)	
±I _S	analog switch ON-state current			0.4		4.0		4.0	μA	10.0	0	V _{IH} or V _{IL}	V _S = V _{CC} - V _{EE} (see Fig. 11)	
I _{CC}	quiescent supply current			8.0 16.0		80.0 160.0		160.0 320.0	μA	6.0 10.0	0 0	V _{CC} or GND	V _{is} = V _{EE} or V _{CC} ; V _{os} = V _{CC} or V _{EE}	

AC CHARACTERISTICS FOR 74HC

GND = 0 V; $t_r = t_f = 6$ ns; $C_L = 50$ pF

SYMBOL	PARAMETER	T _{amb} (°C)						UNIT	TEST CONDITIONS			
		74HC							V _{CC} V	V _{EE} V	OTHER	
		+25			-40 to +85		-40 to +125					
		min.	typ.	max.	min.	max.	min.		max.			
t _{PHL} / t _{PLH}	propagation delay V _{IS} to V _{OS}		14 5 4 4	60 12 10 8		75 15 13 10		90 18 15 12	ns	2.0 4.5 6.0 4.5	0 0 0 -4.5	R _L = ∞; C _L = 50 pF (see Fig. 17)
t _{PZH} / t _{PZL}	turn "ON" time E ₁ to V _{OS}		85 31 25 28	300 60 51 55		375 75 64 69		450 90 77 83	ns	2.0 4.5 6.0 4.5	0 0 0 -4.5	R _L = 1 kΩ; C _L = 50 pF (see Fig. 18)
t _{PZH} / t _{PZL}	turn "ON" time E ₂ to V _{OS}		85 31 25 25	300 60 51 55		375 75 64 69		450 90 77 83	ns	2.0 4.5 6.0 4.5	0 0 0 -4.5	R _L = 1 kΩ; C _L = 50 pF (see Fig. 18)
t _{PZH} / t _{PZL}	turn "ON" time LE to V _{OS}		91 33 26 27	300 60 51 55		375 75 64 69		450 90 77 83	ns	2.0 4.5 6.0 4.5	0 0 0 -4.5	R _L = 1 kΩ; C _L = 50 pF (see Fig. 18)
t _{PZH} / t _{PZL}	turn "ON" time S _N to V _{OS}		88 32 26 25	300 60 51 50		375 75 64 63		450 90 77 75	ns	2.0 4.5 6.0 4.5	0 0 0 -4.5	R _L = 1 kΩ; C _L = 50 pF (see Fig. 18)
t _{PHZ} / t _{PLZ}	turn "OFF" time E ₁ to V _{OS}		69 25 20 20	250 50 43 40		315 63 54 50		375 75 64 60	ns	2.0 4.5 6.0 4.5	0 0 0 -4.5	R _L = 1 kΩ; C _L = 50 pF (see Fig. 18)
t _{PHZ} / t _{PLZ}	turn "OFF" time E ₂ to V _{OS}		72 26 21 19	250 50 43 40		315 63 54 50		375 75 64 60	ns	2.0 4.5 6.0 4.5	0 0 0 -4.5	R _L = 1 kΩ; C _L = 50 pF (see Fig. 18)
t _{PHZ} / t _{PLZ}	turn "OFF" time LE to V _{OS}		83 30 24 26	275 55 47 45		345 69 59 56		415 83 71 68	ns	2.0 4.5 6.0 4.5	0 0 0 -4.5	R _L = 1 kΩ; C _L = 50 pF (see Fig. 18)
t _{PHZ} / t _{PLZ}	turn "OFF" time S _N to V _{OS}		80 29 23 24	275 55 47 48		345 69 59 60		415 83 71 72	ns	2.0 4.5 6.0 4.5	0 0 0 -4.5	R _L = 1 kΩ; C _L = 50 pF (see Fig. 18)
t _{su}	set-up time S _N to LE	60 12 10 18	17 6 5 9			75 15 13 23		90 18 15 27	ns	2.0 4.5 6.0 4.5	0 0 0 -4.5	R _L = 1 kΩ; C _L = 50 pF (see Fig. 19)
t _h	hold time S _N to LE	5 5 5 5	-8 -3 -2 -4			5 5 5 5		5 5 5 5	ns	2.0 4.5 6.0 4.5	0 0 0 -4.5	R _L = 1 kΩ; C _L = 50 pF (see Fig. 19)
t _w	LE minimum pulse width HIGH	100 20 17 25	11 1 3 7			125 25 21 31		150 30 26 38	ns	2.0 4.5 6.0 4.5	0 0 0 -4.5	R _L = 1 kΩ; C _L = 50 pF (see Fig. 19)

DC CHARACTERISTICS FOR 74HCT

Voltages are referenced to GND (ground = 0)

SYMBOL	PARAMETER	T_{amb} (°C)						UNIT	TEST CONDITIONS				
		74HCT							V_{CC} V	V_{EE} V	V_I	OTHER	
		+25			-40 to +85		-40 to +125						
		min.	typ.	max.	min.	max.	min.		max.				
V_{IH}	HIGH level input voltage	2.0	1.6		2.0		2.0		V	4.5 to 5.5			
V_{IL}	LOW level input voltage		1.2	0.8		0.8		0.8	V	4.5 to 5.5			
$\pm I_I$	input leakage current			0.1		1.0		1.0	μA	5.5	0	V_{CC} or GND	
$\pm I_S$	analog switch OFF-state current per channel			0.1		1.0		1.0	μA	10.0	0	V_{IH} or V_{IL}	$ V_S =$ $V_{CC} - V_{EE}$ (see Fig. 10)
$\pm I_S$	analog switch OFF-state current all channels			0.4		4.0		4.0	μA	10.0	0	V_{IH} or V_{IL}	$ V_S =$ $V_{CC} - V_{EE}$ (see Fig. 10)
$\pm I_S$	analog switch ON-state current			0.4		4.0		4.0	μA	10.0	0	V_{IH} or V_{IL}	$ V_S =$ $V_{CC} - V_{EE}$ (see Fig. 11)
I_{CC}	quiescent supply current			8.0 16.0		80.0 160.0		160.0 320.0	μA	5.5 5.0	0 -5.0	V_{CC} or GND	$V_{is} = V_{EE}$ or V_{CC} ; $V_{os} = V_{CC}$ or V_{EE}
ΔI_{CC}	additional quiescent supply current per input pin for unit load coefficient is 1 (note 1)		100	360		450		490	μA	4.5 to 5.5	0	V_{CC} -2.1V	other inputs at V_{CC} or GND

Note to HCT types

1. The value of additional quiescent supply current (ΔI_{CC}) for a unit load of 1 is given here.To determine ΔI_{CC} per input, multiply this value by the unit load coefficient shown in the table below.

INPUT	UNIT LOAD COEFFICIENT
\bar{E}_1, E_2	0.50
S_n	0.50
LE	1.5

AC CHARACTERISTICS FOR 74HCT

GND = 0 V; $t_r = t_f = 6$ ns; $C_L = 50$ pF

SYMBOL	PARAMETER	T_{amb} (°C)						UNIT	TEST CONDITIONS			
		74HCT							V_{CC} V	V_{EE} V	OTHER	
		+25			-40 to +85		-40 to +125					
		min.	typ.	max.	min.	max.	min.		max.			
$t_{PHL}/$ t_{PLH}	propagation delay V_{is} to V_{os}		6 4	12 8		15 10		18 12	ns	4.5 4.5	0 -4.5	$R_L = \infty$; $C_L = 50$ pF (see Fig. 17)
$t_{PZH}/$ t_{PZL}	turn "ON" time \bar{E}_1 to V_{os}		40 31	75 60		94 75		113 90	ns	4.5 4.5	0 -4.5	$R_L = 1$ k Ω ; $C_L = 50$ pF (see Fig. 18)
$t_{PZH}/$ t_{PZL}	turn "ON" time E_2 to V_{os}		35 26	70 50		88 63		105 75	ns	4.5 4.5	0 -4.5	$R_L = 1$ k Ω ; $C_L = 50$ pF (see Fig. 18)
$t_{PZH}/$ t_{PZL}	turn "ON" time $\bar{L}E$ to V_{os}		42 37	75 60		94 75		113 90	ns	4.5 4.5	0 -4.5	$R_L = 1$ k Ω ; $C_L = 50$ pF (see Fig. 18)
$t_{PZH}/$ t_{PZL}	turn "ON" time S_n to V_{os}		39 30	75 60		94 75		113 90	ns	4.5 4.5	0 -4.5	$R_L = 1$ k Ω ; $C_L = 50$ pF (see Fig. 18)
$t_{PHZ}/$ t_{PLZ}	turn "OFF" time \bar{E}_1 to V_{os}		27 20	55 40		69 50		83 60	ns	4.5 4.5	0 -4.5	$R_L = 1$ k Ω ; $C_L = 50$ pF (see Fig. 18)
$t_{PHZ}/$ t_{PLZ}	turn "OFF" time E_2 to V_{os}		32 26	60 50		75 63		90 75	ns	4.5 4.5	0 -4.5	$R_L = 1$ k Ω ; $C_L = 50$ pF (see Fig. 18)
$t_{PHZ}/$ t_{PLZ}	turn "OFF" time $\bar{L}E$ to V_{os}		33 30	60 55		75 69		90 83	ns	4.5 4.5	0 -4.5	$R_L = 1$ k Ω ; $C_L = 50$ pF (see Fig. 18)
$t_{PHZ}/$ t_{PLZ}	turn "OFF" time S_n to V_{os}		33 29	65 55		81 69		98 83	ns	4.5 4.5	0 -4.5	$R_L = 1$ k Ω ; $C_L = 50$ pF (see Fig. 18)
t_{su}	set-up time S_n to $\bar{L}E$	12 14	6 7			15 18		18 21	ns	4.5 4.5	0 -4.5	$R_L = 1$ k Ω ; $C_L = 50$ pF (see Fig. 19)
t_h	hold time S_n to $\bar{L}E$	5 5	-1 -2			5 5		5 5	ns	4.5 4.5	0 -4.5	$R_L = 1$ k Ω ; $C_L = 50$ pF (see Fig. 19)
t_w	$\bar{L}E$ minimum pulse width HIGH	25 25	13 13			31 31		38 38	ns	4.5 4.5	0 -4.5	$R_L = 1$ k Ω ; $C_L = 50$ pF (see Fig. 19)

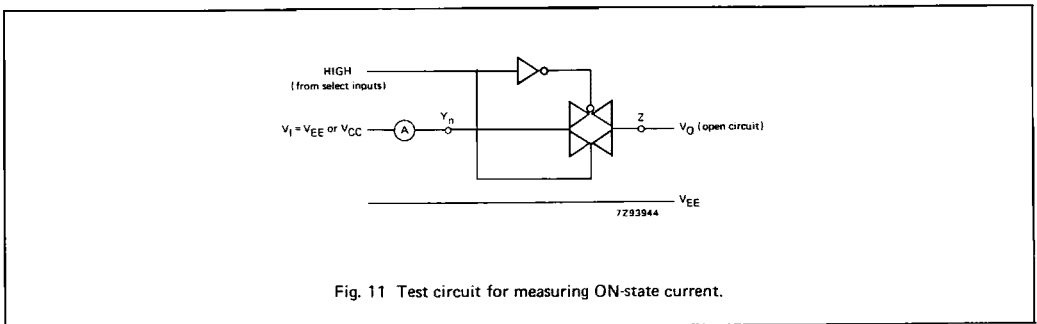
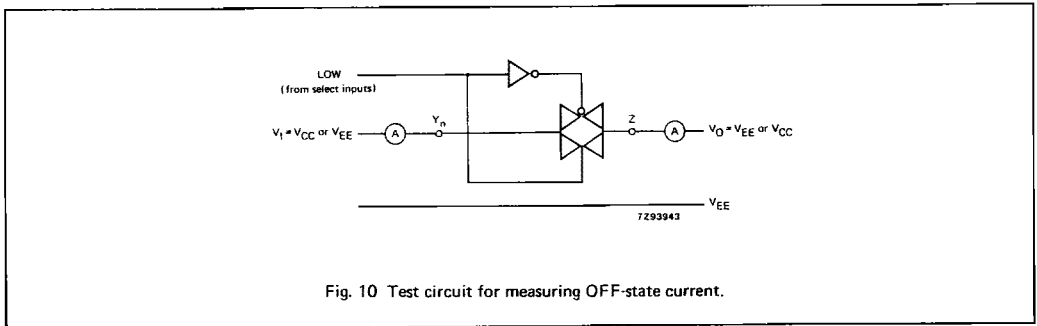
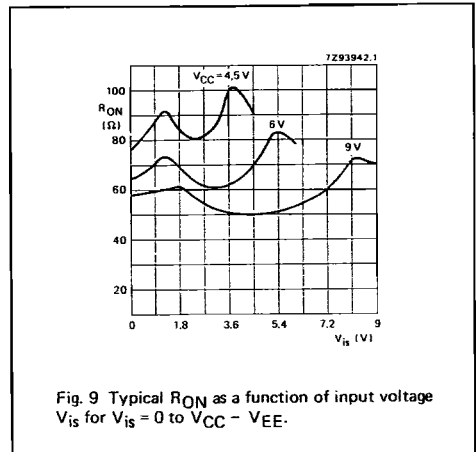
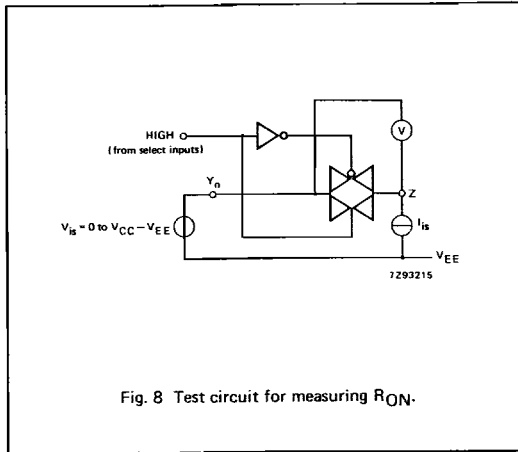

ADDITIONAL AC CHARACTERISTICS FOR 74HC/HCT

Recommended conditions and typical values

GND = 0 V; $T_{amb} = 25\text{ }^{\circ}\text{C}$

SYMBOL	PARAMETER	typ.	UNIT	V _{CC} V	V _{EE} V	V _{is(p-p)} V	CONDITIONS
	sine-wave distortion $f = 1\text{ kHz}$	0.04 0.02	% %	2.25 4.5	-2.25 -4.5	4.0 8.0	$R_L = 10\text{ k}\Omega$; $C_L = 50\text{ pF}$ (see Fig. 14)
	sine-wave distortion $f = 10\text{ kHz}$	0.12 0.06	% %	2.25 4.5	-2.25 -4.5	4.0 8.0	$R_L = 10\text{ k}\Omega$; $C_L = 50\text{ pF}$ (see Fig. 14)
	switch "OFF" signal feed-through	-50 -50	dB dB	2.25 4.5	-2.25 -4.5	note 1	$R_L = 600\text{ }\Omega$; $C_L = 50\text{ pF}$ (see Figs 12 and 15)
$V_{(p-p)}$	crosstalk voltage between control and any switch (peak-to-peak value)	120 220	mV mV	4.5 4.5	0 -4.5		$R_L = 600\text{ }\Omega$; $C_L = 50\text{ pF}$; $f = 1\text{ MHz}$ (E_1 , E_2 or S_n , square-wave between V _{CC} and GND, $t_r = t_f = 6\text{ ns}$) (see Fig. 16)
f_{max}	minimum frequency response (-3dB)	160 170	MHz MHz	2.25 4.5	-2.25 -4.5	note 2	$R_L = 50\text{ }\Omega$; $C_L = 10\text{ pF}$ (see Figs 13 and 14)
C_S	maximum switch capacitance independent (Y) common (Z)	5 25	pF pF				

Notes to AC characteristics

General note

 V_{is} is the input voltage at a Y_n or Z terminal, whichever is assigned as an input. V_{os} is the output voltage at a Y_n or Z terminal, whichever is assigned as an output.

Notes

1. Adjust input voltage V_{is} to 0 dBm level (0 dBm = 1 mW into 600 Ω).
2. Adjust input voltage V_{is} to 0 dBm level at V_{os} for 1 MHz (0 dBm = 1 mW into 50 Ω).

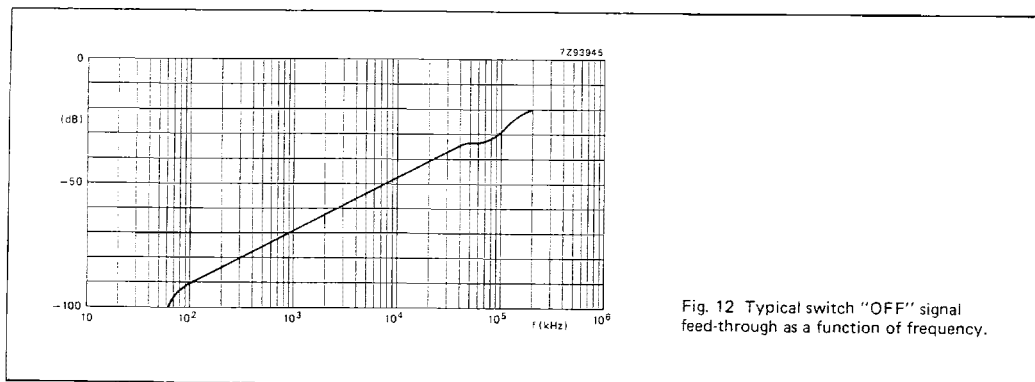
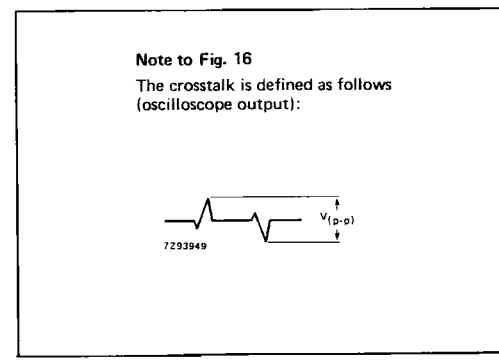
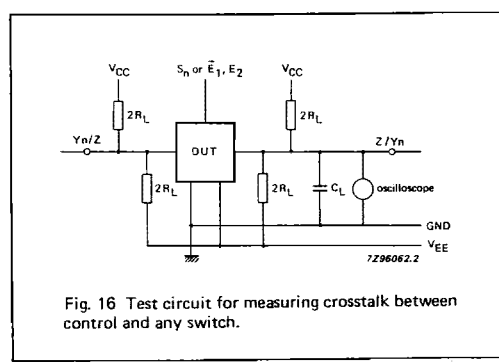
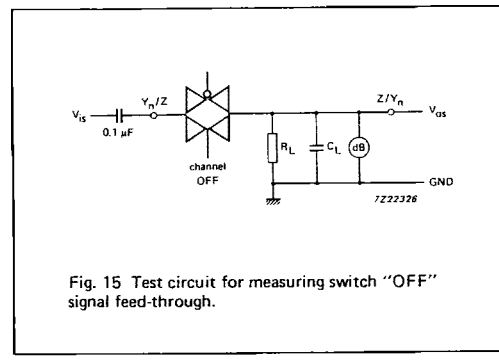
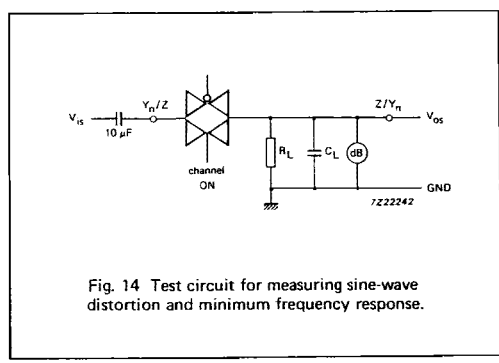
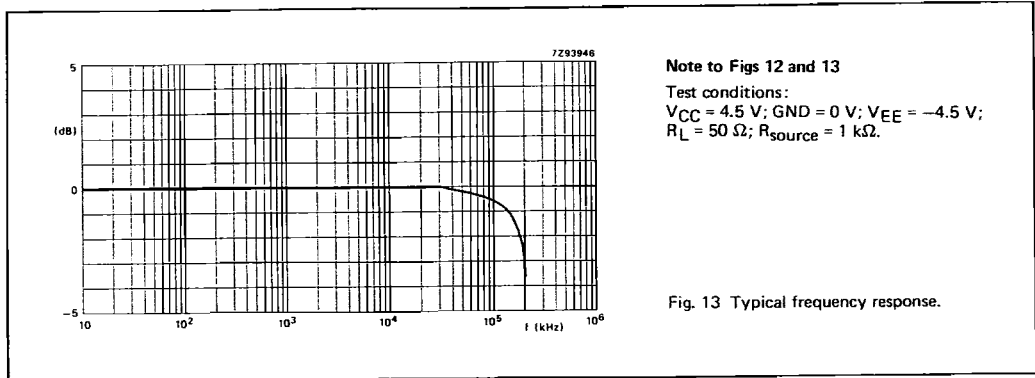
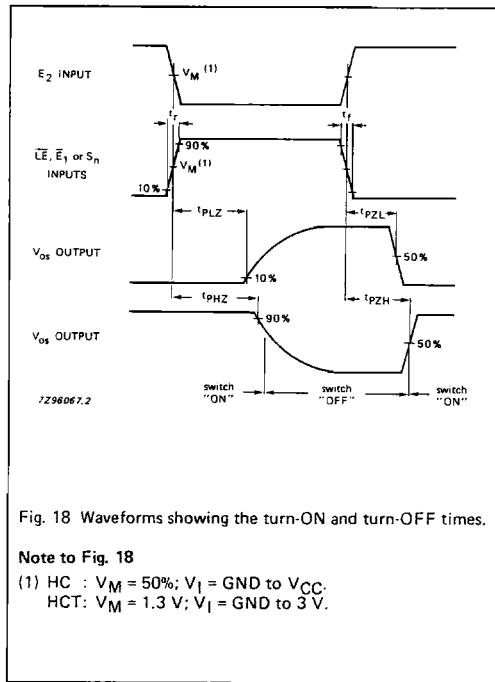
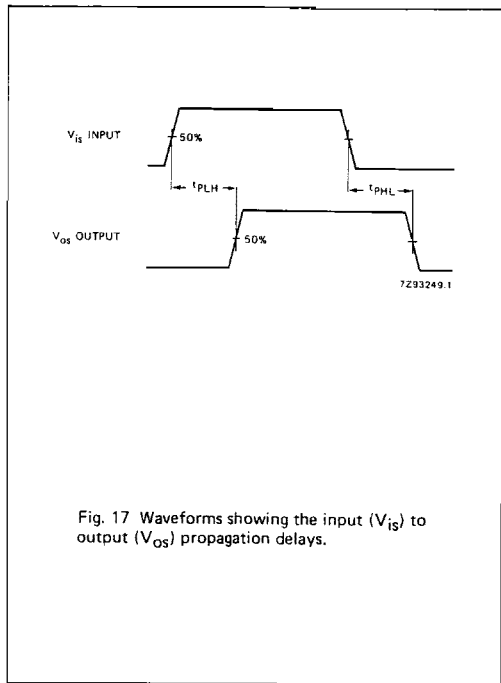

Fig. 12 Typical switch "OFF" signal feed-through as a function of frequency.



AC WAVEFORMS



Note to Fig. 18

- (1) HC : $V_M = 50\%$; $V_I = \text{GND to } V_{CC}$.
- HCT: $V_M = 1.3 \text{ V}$; $V_I = \text{GND to } 3 \text{ V}$.

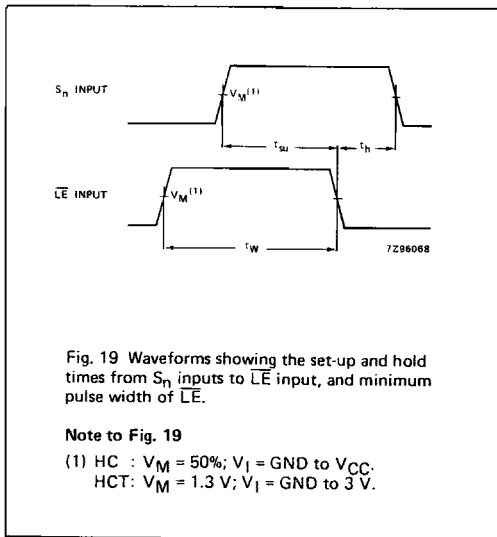

Note to Fig. 19

- (1) HC : $V_M = 50\%$; $V_I = \text{GND to } V_{CC}$.
- HCT: $V_M = 1.3 \text{ V}$; $V_I = \text{GND to } 3 \text{ V}$.

TEST CIRCUIT AND WAVEFORMS

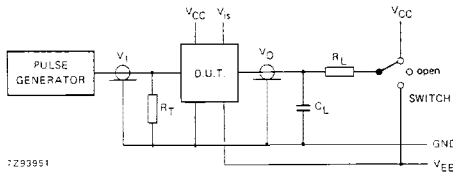

Fig. 20 Test circuit for measuring AC performance.

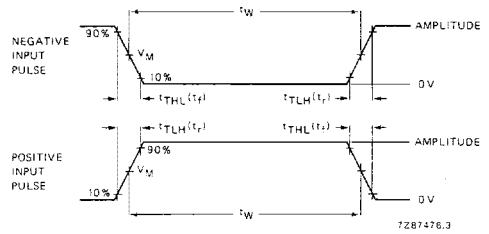

Fig. 21 Input pulse definitions.

Conditions

TEST	SWITCH	V _{is}
t _{PZH}	V _{EE}	V _{CC}
t _{PZL}	V _{CC}	V _{EE}
t _{PHZ}	V _{EE}	V _{CC}
t _{PLZ}	V _{CC}	V _{EE}
others	open	V _{EE} pulse

FAMILY	AMPLITUDE	V _M	t _r , t _f	
			f _{max} ; PULSE WIDTH	OTHER
74HC	V _{CC}	50%	< 2 ns	6 ns
74HCT	3.0 V	1.3 V	< 2 ns	6 ns

Definitions for Figs 20 and 21:

- C_L = load capacitance including jig and probe capacitance (see AC CHARACTERISTICS for values).
- R_T = termination resistance should be equal to the output impedance Z_O of the pulse generator.
- t_r = t_f = 6 ns; when measuring f_{max}, there is no constraint on t_r, t_f with 50% duty factor.