

Features

Excellent image suppression
 Low conversion loss
 Multi-octave RF bandwidths
 Octave IF bandwidths
 Biased versions

Applications

Wideband sweeping receivers
 Spectrum analyzers
 Surveillance receivers
 Wideband test/Instrumentation
 "Starved LO" systems

Description

An image rejection mixer discriminates between the IF signals produced when the LO frequency is above or below the RF signal frequency. Since the IF frequency is the same in both cases, the discrimination cannot be made by filtering, but by means of a phasing technique. Because the magnitude of the two IF signals are equal but one leads or lags the other by 90° depending on which image is present, they can be summed in a quadrature hybrid operating at the IF frequency. One image sums to one hybrid output

port (IF1) and the second sums to the other output port (IF2). Additional image rejection can be obtained by a simple gating scheme (see pages 161-162).

Biased models are available which allow good conversion loss even with reduced LO power. Reduced LO power operation also improves the harmonic intermodulation performance of the mixer.

See pages 161-162 for additional information.

Electrical Specifications

Model No.	RF Input (GHz)	IF Output ⁽¹⁾ (MHz)	Isolation LO/RF Min/Typ (dB)	VSWR Max/Typ		Conversion Loss* Max/Typ (dB)	Image Rejection Min/Typ (dB)	LO Power (dBm)	Bias
				RF	LO				
150015-30	1.0- 2.0	20- 40	15/20	2.0/1.4	2.5/1.5	8.5/7.0	15/20	+ 10	No
150015-60		40- 80	15/20	2.0/1.4	2.5/1.5	8.5/7.0	15/20	+ 10	No
150015-120		80-160	15/20	2.0/1.4	2.5/1.5	8.5/7.0	15/20	+ 10	No
150135-30	1.0- 2.0	20- 40	15/20	2.0/1.4	2.5/1.5	9.0/7.5	15/20	Note (2)	Yes
150135-60		40- 80	15/20	2.0/1.4	2.5/1.5	9.0/7.5	15/20	Note (2)	Yes
150135-120		80-160	15/20	2.0/1.4	2.5/1.5	9.0/7.5	15/20	Note (2)	Yes
150050-30	1.2-12.4	20- 40	9/15	2.0/1.5	2.5/1.6	10/7.5	14/18	+ 13	No
150050-60		40- 80	9/15	2.0/1.5	2.5/1.6	10/7.5	14/18	+ 13	No
150050-120		80-160	9/15	2.0/1.5	2.5/1.6	10/7.5	14/18	+ 13	No

*Approximately .5 dB degradation @+95°C.

(continued)

Electrical Specifications (Continued)

Model No.	RF Input (GHz)	IF Output ⁽¹⁾ (MHz)	Isolation LO/RF Min/Typ (dB)	VSWR Max/Typ		Conversion Loss* Max/Typ (dB)	Image Rejection Min/Typ (dB)	LO Power (dBm)	Bias
				RF	LO				
150016-30	2.0- 4.0	20- 40	15/20	2.0/1.5	2.5/1.6	8.5/7.0	15/20	+ 10	No
150016-60		40- 80	15/20	2.0/1.5	2.5/1.6	8.5/7.0	15/20	+ 10	No
150016-120		80-160	15/20	2.0/1.5	2.5/1.6	8.5/7.0	15/20	+ 10	No
150016-240		160-320	15/20	2.0/1.5	2.5/1.6	8.5/7.0	15/20	+ 10	No
150136-30	2.0- 4.0	20- 40	15/20	2.0/1.5	2.5/1.6	9.0/7.5	15/20	Note (2)	Yes
150136-60		40- 80	15/20	2.0/1.5	2.5/1.6	9.0/7.5	15/20	Note (2)	Yes
150136-120		80-160	15/20	2.0/1.5	2.5/1.6	9.0/7.5	15/20	Note (2)	Yes
150136-240		160-320	15/20	2.0/1.5	2.5/1.6	9.0/7.5	15/20	Note (2)	Yes
150030-30	3.7- 6.4	20- 40	15/20	2.0/1.5	2.5/1.6	9.0/7.5	15/20	+ 10	No
150030-60		40- 80	15/20	2.0/1.5	2.5/1.6	9.0/7.5	15/20	+ 10	No
150030-120		80-160	15/20	2.0/1.5	2.5/1.6	9.0/7.5	15/20	+ 10	No
150030-240		160-320	15/20	2.0/1.5	2.5/1.6	9.0/7.5	15/20	+ 10	No
150017-30	4.0- 8.0	20- 40	15/20	2.0/1.6	2.5/1.7	9.0/7.5	15/20	+ 10	No
150017-60		40- 80	15/20	2.0/1.6	2.5/1.7	9.0/7.5	15/20	+ 10	No
150017-120		80-160	15/20	2.0/1.6	2.5/1.7	9.0/7.5	15/20	+ 10	No
150017-240		160-320	15/20	2.0/1.6	2.5/1.7	9.0/7.5	15/20	+ 10	No
150137-30	4.0- 8.0	20- 40	15/20	2.0/1.6	2.5/1.7	9.5/8.0	15/20	Note (2)	Yes
150137-60		40- 80	15/20	2.0/1.6	2.5/1.7	9.5/8.0	15/20	Note (2)	Yes
150137-120		80-160	15/20	2.0/1.6	2.5/1.7	9.5/8.0	15/20	Note (2)	Yes
150137-240		160-320	15/20	2.0/1.6	2.5/1.7	9.5/8.0	15/20	Note (2)	Yes
15B0230-60	7.0-16.0	40- 80	10/20	2.5/1.7	3.0/1.8	13/10	12/18	Note (2)	Yes
15B0230-120		80- 160	10/20	2.5/1.7	3.0/1.8	13/10	12/18	Note (2)	Yes
15B0230-240		160- 320	10/20	2.5/1.7	3.0/1.8	13/10	12/18	Note (2)	Yes
15B0230-480		320- 640	10/20	2.5/1.7	3.0/1.8	13/10	12/18	Note (2)	Yes
15B0230-750		500-1000	10/20	2.5/1.7	3.0/1.8	13/10	12/18	Note (2)	Yes
150018-30	8.0-12.4	20- 40	15/20	2.0/1.6	2.5/1.7	9.5/8.0	15/20	+ 10	No
150018-60		40- 80	15/20	2.0/1.6	2.5/1.7	9.5/8.0	15/20	+ 10	No
150018-120		80-160	15/20	2.0/1.6	2.5/1.7	9.5/8.0	15/20	+ 10	No
150018-240		160-320	15/20	2.0/1.6	2.5/1.7	9.5/8.0	15/20	+ 10	No
150138-30	8.0-12.4	20- 40	15/20	2.0/1.6	2.5/1.7	10.0/8.5	15/20	Note (2)	Yes
150138-60		40- 80	15/20	2.0/1.6	2.5/1.7	10.0/8.5	15/20	Note (2)	Yes
150138-120		80-160	15/20	2.0/1.6	2.5/1.7	10.0/8.5	15/20	Note (2)	Yes
150138-240		160-320	15/20	2.0/1.6	2.5/1.7	10.0/8.5	15/20	Note (2)	Yes
150019-30	12.4-18.0	20- 40	12/18	2.5/1.7	3.0/1.8	10.0/8.5	15/20	+ 10	No
150019-60		40- 80	12/18	2.5/1.7	3.0/1.8	10.0/8.5	15/20	+ 10	No
150019-120		80-160	12/18	2.5/1.7	3.0/1.8	10.0/8.5	15/20	+ 10	No
150019-240		160-320	12/18	2.5/1.7	3.0/1.8	10.0/8.5	15/20	+ 10	No
150139-30	12.4-18.0	20- 40	12/18	2.5/1.7	3.0/1.8	10.5/9.0	15/20	Note (2)	Yes
150139-60		40- 80	12/18	2.5/1.7	3.0/1.8	10.5/9.0	15/20	Note (2)	Yes
150139-120		80-160	12/18	2.5/1.7	3.0/1.8	10.5/9.0	15/20	Note (2)	Yes
150139-240		160-320	12/18	2.5/1.7	3.0/1.8	10.5/9.0	15/20	Note (2)	Yes

(1) Measurement made at IF band center

(2) Biased mixer specifications are with 0 dBm LO power. Internal resistors (optimum load-line technique) optimize conversion loss for any LO power. + 12V bias required.

*Approximately .5 dB degradation @+95°C.

Mechanical Specifications

Model No.	A		B		C		D		E		F		Figure No.	Weight	
	in	mm	in	mm	in	mm	in	mm	in	mm	in	mm		oz	gm
150015-30	3.00	76	2.50	64	2.75	70	2.00	51	2.00	51	1.95	50	1	7.4	210
150015-60	3.00	76	2.50	64	2.75	70	2.00	51	2.00	51	1.95	50	1	7.4	210
150015-120	3.00	76	2.50	64	2.75	70	2.00	51	2.00	51	1.95	50	1	7.4	210
150016-30	3.00	76	2.50	64	2.75	70	2.00	51	2.00	51	1.95	50	1	7.4	210
150016-60	3.00	76	2.50	64	2.75	70	2.00	51	2.00	51	1.95	50	1	7.4	210
150016-120	3.00	76	2.50	64	2.75	70	2.00	51	2.00	51	1.95	50	1	7.4	210
150016-240	3.00	76	2.50	64	2.75	70	2.00	51	2.00	51	1.95	50	1	7.4	210
150017-30	3.00	76	2.50	64	2.75	70	2.00	51	2.00	51	1.95	50	1	7.4	210
150017-60	3.00	76	2.50	64	2.75	70	2.00	51	2.00	51	1.95	50	1	7.4	210
150017-120	3.00	76	2.50	64	2.75	70	2.00	51	2.00	51	1.95	50	1	7.4	210
150017-240	3.00	76	2.50	64	2.75	70	2.00	51	2.00	51	1.95	50	1	7.4	210
150018-30	3.00	76	2.50	64	2.75	70	2.00	51	2.00	51	1.95	50	1	7.4	210
150018-60	3.00	76	2.50	64	2.75	70	2.00	51	2.00	51	1.95	50	1	7.4	210
150018-120	3.00	76	2.50	64	2.75	70	2.00	51	2.00	51	1.95	50	1	7.4	210
150018-240	3.00	76	2.50	64	2.75	70	2.00	51	2.00	51	1.95	50	1	7.4	210
150019-30	3.00	76	2.50	64	2.75	70	2.00	51	2.00	51	1.95	50	3	7.4	210
150019-60	3.00	76	2.50	64	2.75	70	2.00	51	2.00	51	1.95	50	3	7.4	210
150019-120	3.00	76	2.50	64	2.75	70	2.00	51	2.00	51	1.95	50	3	7.4	210
150019-240	3.00	76	2.50	64	2.75	70	2.00	51	2.00	51	1.95	50	3	7.4	210
150030-30	3.00	76	2.50	64	2.75	70	2.00	51	2.00	51	1.95	50	1	7.4	210
150030-60	3.00	76	2.50	64	2.75	70	2.00	51	2.00	51	1.95	50	1	7.4	210
150030-120	3.00	76	2.50	64	2.75	70	2.00	51	2.00	51	1.95	50	1	7.4	210
150030-240	3.00	76	2.50	64	2.75	70	2.00	51	2.00	51	1.95	50	1	7.4	210
150050-30	4.20	107	2.70	69	3.95	100	3.20	81	1.70	43	2.75	70	4	10.7	305
150050-60	4.20	107	2.70	69	3.95	100	3.20	81	1.70	43	2.75	70	4	10.7	305
150050-120	4.20	107	2.70	69	3.95	100	3.20	81	1.70	43	2.75	70	4	10.7	305
150135-30	3.00	76	2.50	64	2.75	70	2.00	51	2.00	51	1.95	50	2	6.4	181
150135-60	3.00	76	2.50	64	2.75	70	2.00	51	2.00	51	1.95	50	2	6.4	181
150135-120	3.00	76	2.50	64	2.75	70	2.00	51	2.00	51	1.95	50	2	6.4	181
150136-30	3.00	76	2.50	64	2.75	70	2.00	51	2.00	51	1.95	50	2	6.4	181
150136-60	3.00	76	2.50	64	2.75	70	2.00	51	2.00	51	1.95	50	2	6.4	181
150136-120	3.00	76	2.50	64	2.75	70	2.00	51	2.00	51	1.95	50	2	6.4	181
150136-240	3.00	76	2.50	64	2.75	70	2.00	51	2.00	51	1.95	50	2	6.4	181
150137-30	3.00	76	2.50	64	2.75	70	2.00	51	2.00	51	1.95	50	2	6.4	181
150137-60	3.00	76	2.50	64	2.75	70	2.00	51	2.00	51	1.95	50	2	6.4	181
150137-120	3.00	76	2.50	64	2.75	70	2.00	51	2.00	51	1.95	50	2	6.4	181
150137-240	3.00	76	2.50	64	2.75	70	2.00	51	2.00	51	1.95	50	2	6.4	181
150138-30	3.00	76	2.50	64	2.75	70	2.00	51	2.00	51	1.95	50	2	6.4	181
150138-60	3.00	76	2.50	64	2.75	70	2.00	51	2.00	51	1.95	50	2	6.4	181
150138-120	3.00	76	2.50	64	2.75	70	2.00	51	2.00	51	1.95	50	2	6.4	181
150138-240	3.00	76	2.50	64	2.75	70	2.00	51	2.00	51	1.95	50	2	6.4	181
150139-30	3.00	76	2.50	64	2.75	70	2.00	51	2.00	51	1.95	50	2	6.4	181
150139-60	3.00	76	2.50	64	2.75	70	2.00	51	2.00	51	1.95	50	2	6.4	181
150139-120	3.00	76	2.50	64	2.75	70	2.00	51	2.00	51	1.95	50	2	6.4	181
150139-240	3.00	76	2.50	64	2.75	70	2.00	51	2.00	51	1.95	50	2	6.4	181
15B0230-60	3.40	86	2.30	58	3.15	80	2.40	61	1.15	29	1.70	43	5	7.4	210
15B0230-120	3.40	86	2.30	58	3.15	80	2.40	61	1.15	29	1.70	43	5	7.4	210
15B0230-240	3.40	86	2.30	58	3.15	80	2.40	61	1.15	29	1.70	43	5	7.4	210
15B0230-480	3.40	86	2.30	58	3.15	80	2.40	61	1.15	29	1.70	43	5	7.4	210
15B0230-750	3.40	86	2.30	58	3.15	80	2.40	61	1.15	29	1.70	43	5	7.4	210

Figure 1

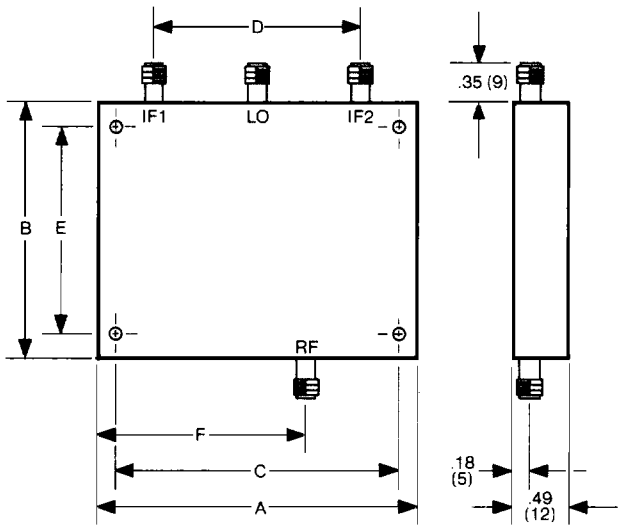

Figure 2

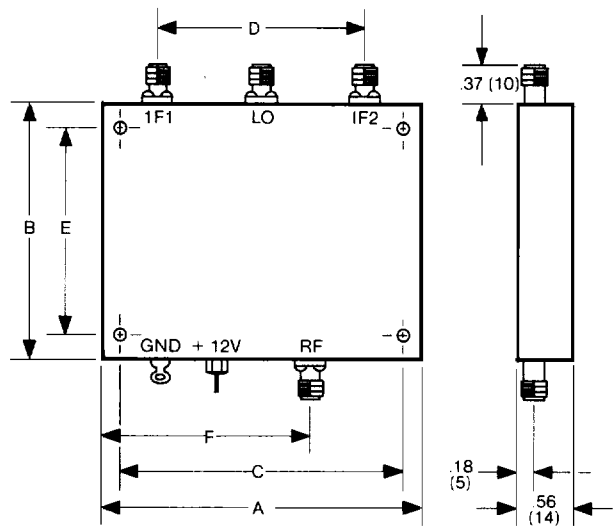

Figure 3

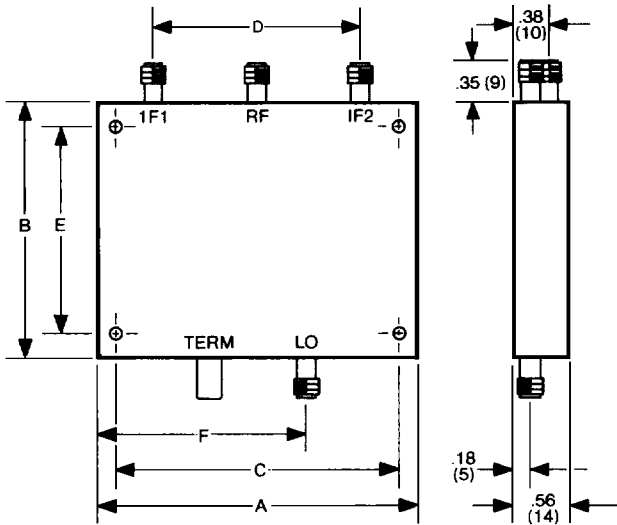

Figure 4

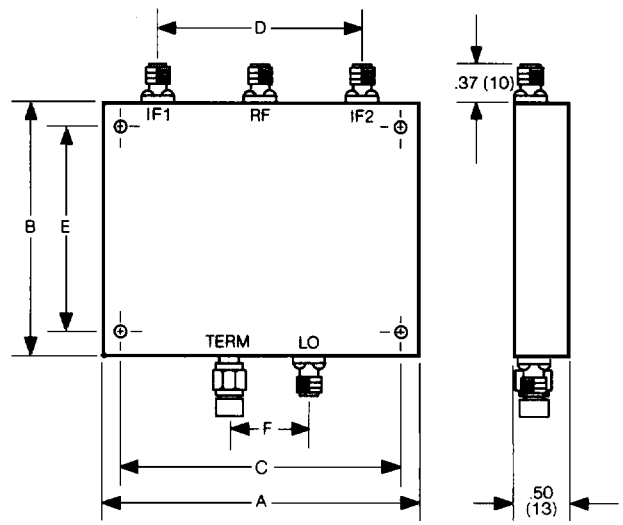
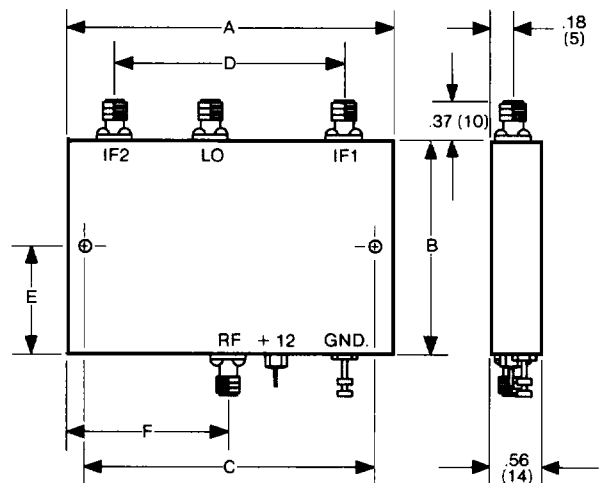

Figure 5



Contact Anaren for latest outline details.

All dimensions in inches & (mm)
 Connectors: SMA, female, Per MIL-C-39012
 Mounting hole dia.: .145 ± .005 (3.7 ± .1)

Specifications subject to change without notice.