

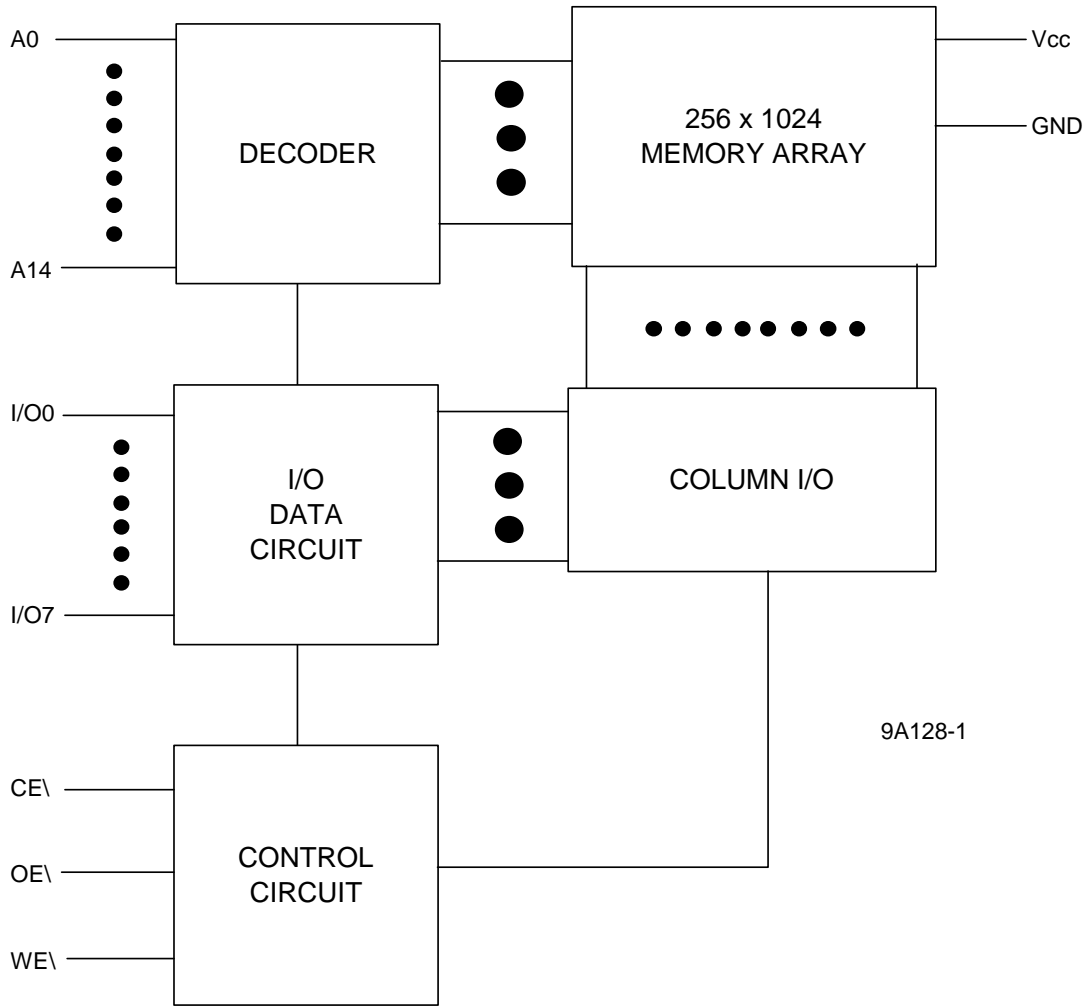



**FUNCTIONAL BLOCK DIAGRAM**



**TRUTHTABLE**

MODE	OE\	CE\	WE\	DQ	POWER
STANDBY	X	H	X	HIGH-Z	STANDBY
READ	L	L	H	Q	ACTIVE
READ	H	L	H	HIGH-Z	ACTIVE
WRITE	X	L	L	D	ACTIVE



**ABSOLUTE MAXIMUM RATINGS\***

Voltage on Any Input or DQ Relative to Vss.....	-0.5V to V <sub>CC</sub> +0.5V
Voltage on V <sub>CC</sub> Supply Relative to Vss.....	-1V to +7V
Storage Temperature.....	-65°C to +150°C
Power Dissipation.....	1W
Short Circuit Output Current.....	50mA
Lead Temperature (soldering 10 seconds).....	+260°C
Max. Junction Temperature.....	+175°C

\*Stresses greater than those listed under "Absolute Maximum Ratings" may cause permanent damage to the device. This is a stress rating only and functional operation of the device at these or any other conditions above those indicated in the operation section of this specification is not implied. Exposure to absolute maximum rating conditions for extended periods may affect reliability.

**ELECTRICAL CHARACTERISTICS AND RECOMMENDED DC OPERATING CONDITIONS**

(-55°C ≤ T<sub>C</sub> ≤ 125°C or -40°C to +85°C; V<sub>CC</sub> = 5.0V ±10%)

DESCRIPTION	CONDITIONS	SYM	MIN	MAX	UNITS	NOTES
Input High (Logic 1) Voltage		V <sub>IH</sub>	2.2	V <sub>CC</sub> +0.5	V	1
Input Low (Logic 0) Voltage		V <sub>IL</sub>	-0.5	0.8	V	1,2
Input Leakage Current	0V ≤ V <sub>IN</sub> ≤ V <sub>CC</sub>	I <sub>LI</sub>	-10	10	μA	
Output Leakage Current	Output(s) disabled 0V ≤ V <sub>OUT</sub> ≤ V <sub>CC</sub>	I <sub>LO</sub>	-10	10	μA	
Output High Voltage	I <sub>OH</sub> = -4.0mA	V <sub>OH</sub>	2.4		V	1
Output Low Voltage	I <sub>OL</sub> = 8.0mA	V <sub>OL</sub>		0.4	V	1

DESCRIPTION	CONDITIONS	SYM	MAX						UNITS	NOTES
			-12	-15	-20	-25	-35	-45		
Power Supply Current: Operating	CE ≤ V <sub>IL</sub> ; V <sub>CC</sub> = MAX f = MAX = 1/τ <sub>RC</sub> (MIN) Output Open	I <sub>CC</sub>	190	180	170	160	150	150	mA	3
Power Supply Current: Standby	TTL CE ≤ V <sub>IH</sub> ; Outputs Open V <sub>CC</sub> = MAX	I <sub>SBT</sub>	60	50	40	35	35	35	mA	
	CMOS CE ≥ V <sub>CC</sub> -0.2V; V <sub>CC</sub> = MAX V <sub>IN</sub> ≤ +0.2V or ≥ V <sub>CC</sub> -0.2V; f = 0 Hz, Outputs Open	I <sub>SBC</sub>	20	20	20	20	20	20	mA	
	"L" Version Only	I <sub>SBC2</sub>	4	4	4	4	4	4	mA	

**CAPACITANCE**

PARAMETER	CONDITIONS	SYM	MAX	UNITS	NOTES
Input Capacitance	T <sub>A</sub> = 25°C, f = 1MHz V <sub>CC</sub> = 5V	C <sub>IN</sub>	11	pF	4
Output Capacitance		C <sub>IO</sub>	11	pF	4



**ELECTRICAL CHARACTERISTICS AND RECOMMENDED AC OPERATING CONDITIONS**

(Note 5) ( $-55^{\circ}\text{C} \leq T_c \leq 125^{\circ}\text{C}$  or  $-40^{\circ}\text{C}$  to  $+85^{\circ}\text{C}$ ;  $V_{cc} = 5.0\text{V} \pm 10\%$ )

DESCRIPTION	SYM	-12		-15		-20		-25		-35		-45		UNITS	NOTES
		MIN	MAX	MIN	MAX	MIN	MAX	MIN	MAX	MIN	MAX	MIN	MAX		
<b>READ CYCLE</b>															
READ cycle time	t <sub>RC</sub>	12		15		20		25		35		45		ns	
Address access time	t <sub>AA</sub>		12		15		20		25		35		45	ns	
Chip enable access time	t <sub>ACE</sub>		12		15		20		25		35		45	ns	
Output hold from address change	t <sub>OH</sub>	2		3		3		3		3		3		ns	
Chip enable to output in Low-Z	t <sub>LZCE</sub>	2		3		3		3		3		3		ns	7
Chip disable to output in High-Z	t <sub>HZCE</sub>		7		10		10		15		35		20	ns	6, 7
Output enable to access time	t <sub>AOE</sub>		6		8		10		15		20		20	ns	
Output enable to output in Low-Z	t <sub>LZOE</sub>	0		0		0		0		2		0		ns	
Output disable to output in High-Z	t <sub>HZOE</sub>		7		10		10		15		35		20	ns	6
<b>WRITE CYCLE</b>															
WRITE cycle time	t <sub>WC</sub>	12		15		20		25		35		45		ns	
Chip enable to end of write	t <sub>CW</sub>	10		12		15		20		30		40		ns	
Address valid to end of write	t <sub>AW</sub>	10		12		15		20		30		40		ns	
Address setup time	t <sub>AS</sub>	0		0		0		0		0		0		ns	
Address hold from end of write	t <sub>AH</sub>	2		0		0		0		0		0		ns	
WRITE pulse width	t <sub>WP</sub>	10		12		15		20		30		40		ns	
Data setup time	t <sub>DS</sub>	8		10		10		15		20		20		ns	
Data hold time	t <sub>DH</sub>	0		0		0		0		0		3		ns	
Write disable to output in Low-Z	t <sub>LZWE</sub>	0		0		0		3		3		3		ns	7
Write enable to output in High-Z	t <sub>HZWE</sub>		7		10		10		15		35		20	ns	6, 7



**ACTEST CONDITIONS**

Input pulse levels.....	V <sub>SS</sub> to 3V
Input rise and fall times.....	5ns
Input timing reference level.....	1.5V
Output reference level.....	1.5V
Output load.....	See figures 1 & 2

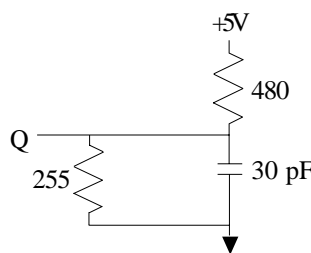

Fig. 1  
OUTPUT LOAD  
EQUIVALENT

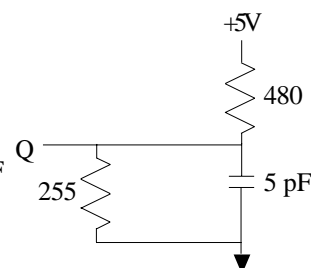

Fig. 2  
OUTPUT LOAD  
EQUIVALENT

**NOTES**

- All voltages referenced to V<sub>SS</sub> (GND).
- 3V for pulse width < 20ns
- I<sub>CC</sub> is dependent on output loading and cycle rates. The specified value applies with the outputs unloaded, and  $f = \frac{1}{RC (MIN)}$  Hz.
- This parameter is guaranteed but not tested.
- Test conditions as specified with the output loading as shown in Fig. 1 unless otherwise noted.
- <sup>H</sup>ZCE, <sup>H</sup>ZOE and <sup>H</sup>ZWE are specified with CL = 5pF as in Fig. 2. Transition is measured ±500mV typical from steady state voltage, allowing for actual tester RC time constant.
- At any given temperature and voltage condition, <sup>H</sup>ZCE is less than <sup>L</sup>ZCE, and <sup>H</sup>ZWE is less than <sup>L</sup>ZWE.
- WE\ is HIGH for READ cycle.
- Device is continuously selected. Chip enables and output enables are held in their active state.
- Address valid prior to, or coincident with, latest occurring chip enable.
- <sup>H</sup>RC = Read Cycle Time.
- Chip enable (CE\ ) and write enable (WE\ ) can initiate and terminate a WRITE cycle.

**DATA RETENTION ELECTRICAL CHARACTERISTICS (L Version Only)**

DESCRIPTION	CONDITIONS	SYM	MIN	MAX	UNITS	NOTES
V <sub>CC</sub> for Retention Data		V <sub>DR</sub>	2		V	
Data Retention Current	CE\ ≥ (V <sub>CC</sub> -0.2V) V <sub>IN</sub> ≥ (V <sub>CC</sub> -0.2V) or ≤ 0.2V	I <sub>CCDR</sub>		1	mA	
Chip Deselect to Data Retention Time		t <sub>CDR</sub>	0	--	ns	4
Operation Recovery Time		t <sub>R</sub>	t <sub>RC</sub>		ns	4, 11

**LOW V<sub>CC</sub> DATA RETENTION WAVEFORM**

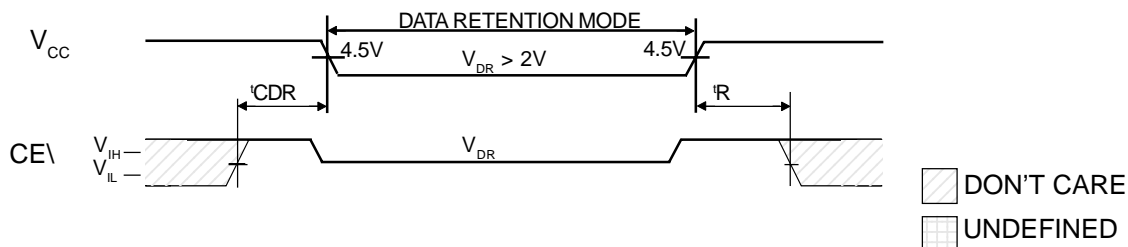



**READ CYCLE NO. 1** 8, 9

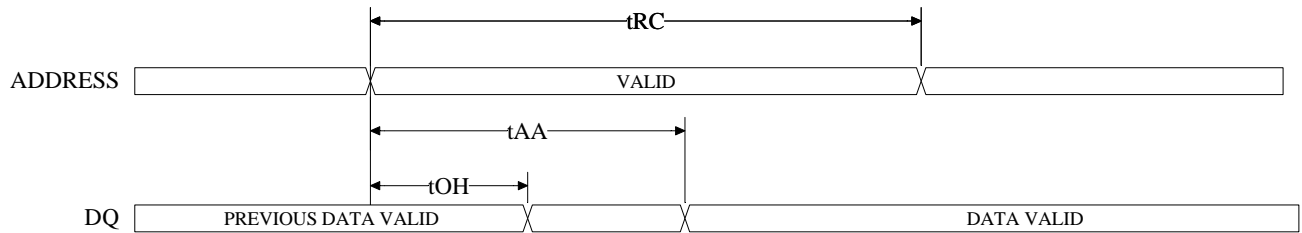

**READ CYCLE NO. 2** 7, 8, 10, 12

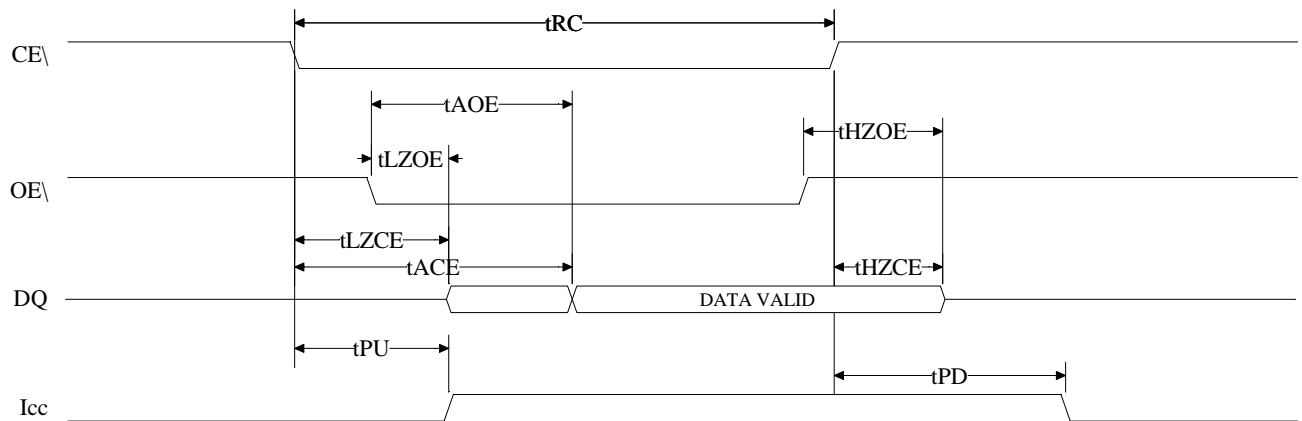



**WRITE CYCLE NO. 1** <sup>12</sup>  
(Chip Enabled Controlled)

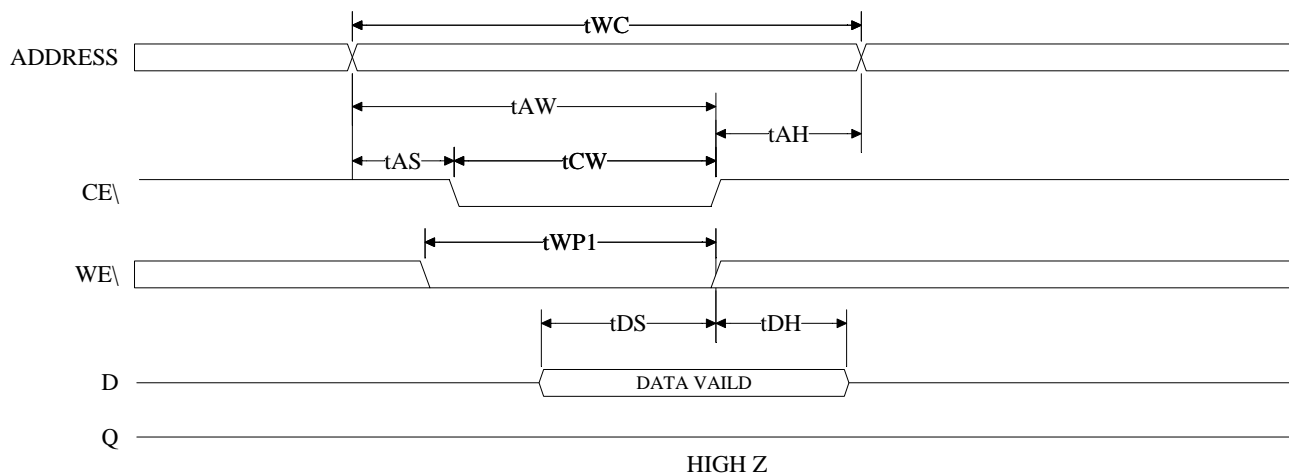

**WRITE CYCLE NO. 2** <sup>7, 12</sup>  
(Write Enabled Controlled)

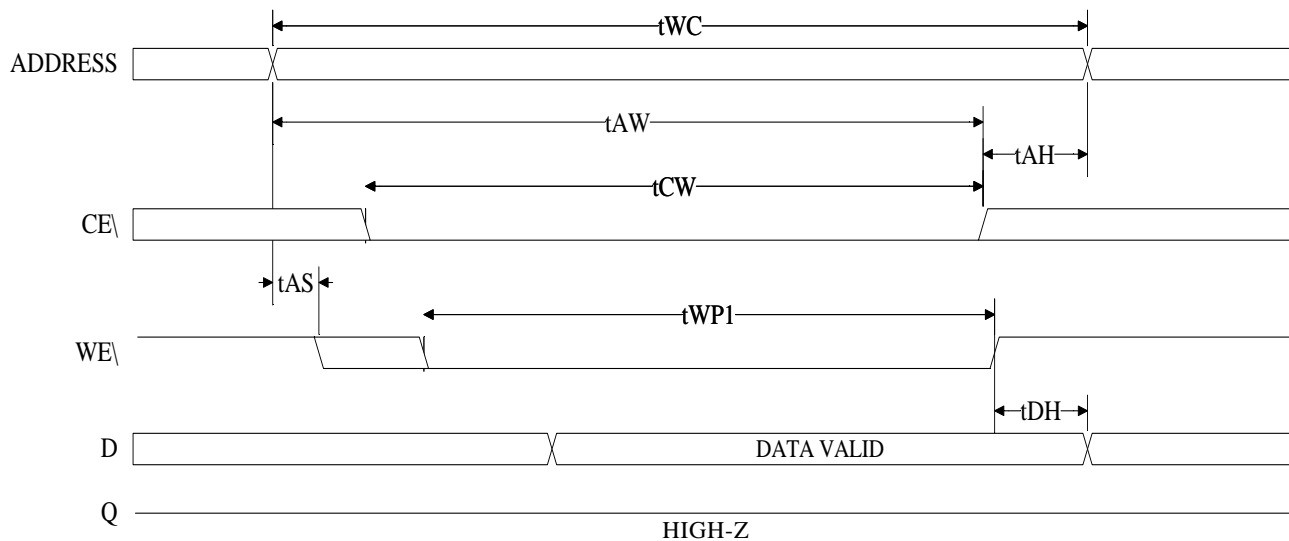

**NOTE:** Output enable (OE) is inactive (HIGH).



**MECHANICAL DEFINITIONS\***

ASI Case #108 (Package Designator C)  
SMD 5962-88662, Case Outline N

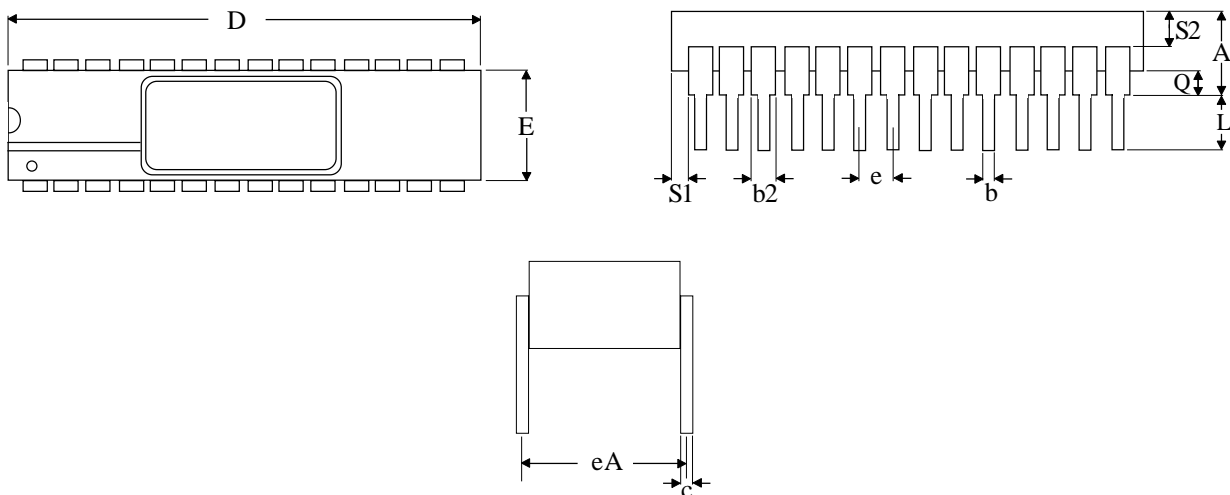

SYMBOL	SMD SPECIFICATIONS	
	MIN	MAX
A	---	0.225
b	0.014	0.026
b2	0.045	0.065
c	0.008	0.018
D	---	1.485
E	0.240	0.310
eA	0.300 BSC	
e	0.100 BSC	
L	0.125	0.200
Q	0.015	0.070
S1	0.005	---
S2	0.005	---

**NOTE:** These dimensions are per the SMD. ASI's package dimensional limits may differ, but they will be within the SMD limits.

\* All measurements are in inches.





**MECHANICAL DEFINITIONS\***

ASI Case #110 (Package Designator CW)  
SMD 5962-88662, Case Outline X

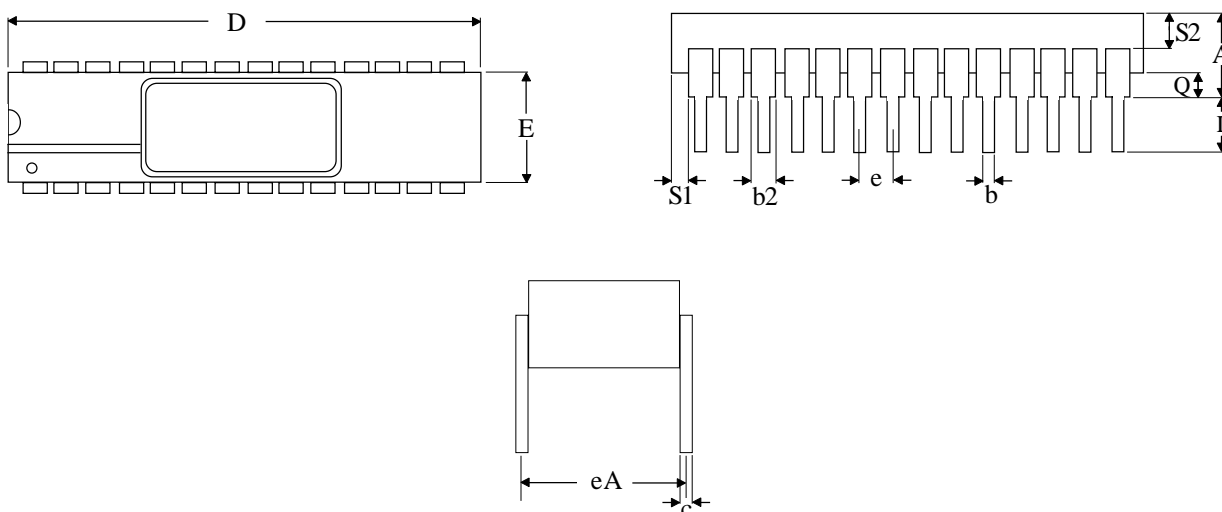

SYMBOL	SMD SPECIFICATIONS	
	MIN	MAX
A	---	0.232
b	0.014	0.026
b2	0.045	0.065
c	0.008	0.018
D	---	1.490
E	0.500	0.610
eA	0.600 BSC	
e	0.100 BSC	
L	0.125	0.200
Q	0.015	0.060
S1	0.005	---
S2	0.005	---

**NOTE:** These dimensions are per the SMD. ASI's package dimensional limits may differ, but they will be within the SMD limits.

\* All measurements are in inches.



**MECHANICAL DEFINITIONS\***

ASI Case #204 (Package Designator EC)  
SMD 5962-88662, Case Outline U

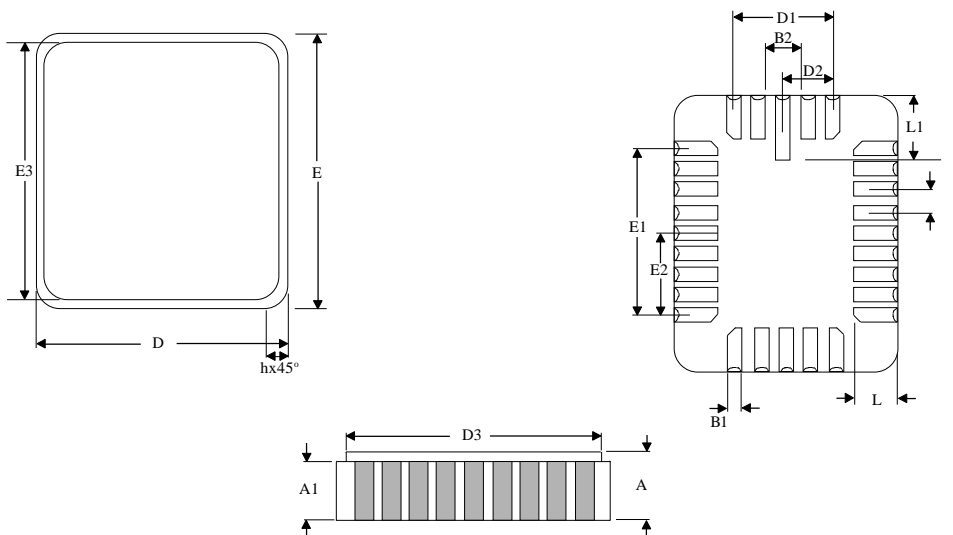

SYMBOL	SMD SPECIFICATIONS	
	MIN	MAX
A	0.060	0.120
A1	0.050	0.088
B1	0.022	0.028
B2	0.072 REF	
D	0.342	0.358
D1	0.200 BSC	
D2	0.100 BSC	
D3	---	0.358
E	0.540	0.560
E1	0.400 BSC	
E2	0.200 BSC	
E3	---	0.558
e	0.050 BSC	
h	0.040 REF	
L	0.045	0.055
L1	0.075	0.095

**NOTE:** These dimensions are per the SMD. ASI's package dimensional limits may differ, but they will be within the SMD limits.

\* All measurements are in inches.



**MECHANICAL DEFINITIONS\***

ASI Case #208 (Package Designator ECW)  
SMD 5962-88662, Case Outline Y

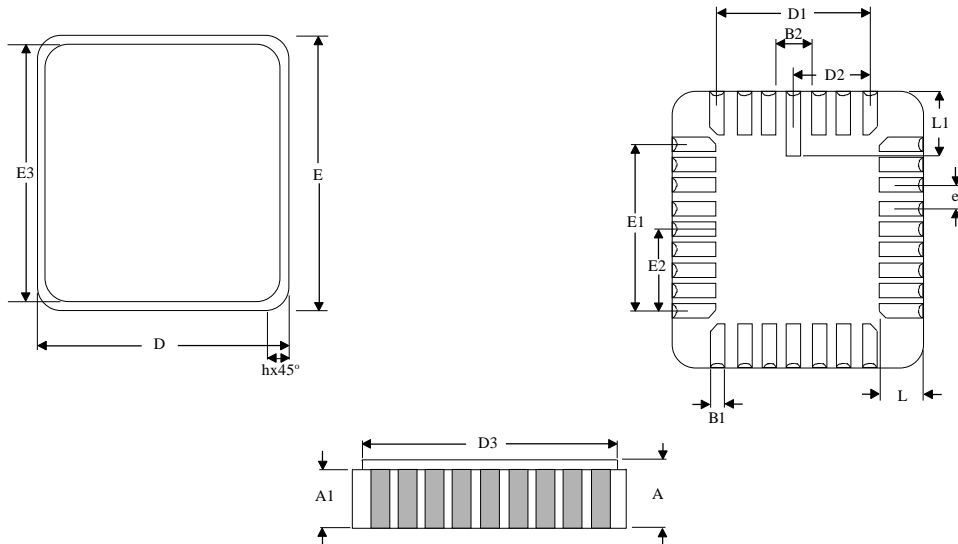

SYMBOL	SMD SPECIFICATIONS	
	MIN	MAX
A	0.060	0.120
A1	0.050	0.088
B1	0.022	0.028
B2	0.072 REF	
D	0.442	0.458
D1	0.300 BSC	
D2	0.150 BSC	
D3	---	0.458
E	0.540	0.560
E1	0.400 BSC	
E2	0.200 BSC	
E3	---	0.558
e	0.050 BSC	
h	0.040 REF	
L	0.045	0.055
L1	0.075	0.095

**NOTE:** These dimensions are per the SMD. ASI's package dimensional limits may differ, but they will be within the SMD limits.

\* All measurements are in inches.



**MECHANICAL DEFINITIONS\***

ASI Case #302 (Package Designator F)  
SMD 5962-88662, Case Outline T

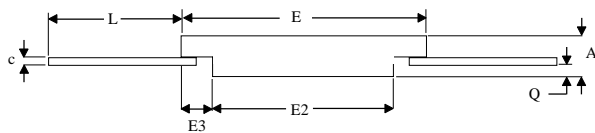
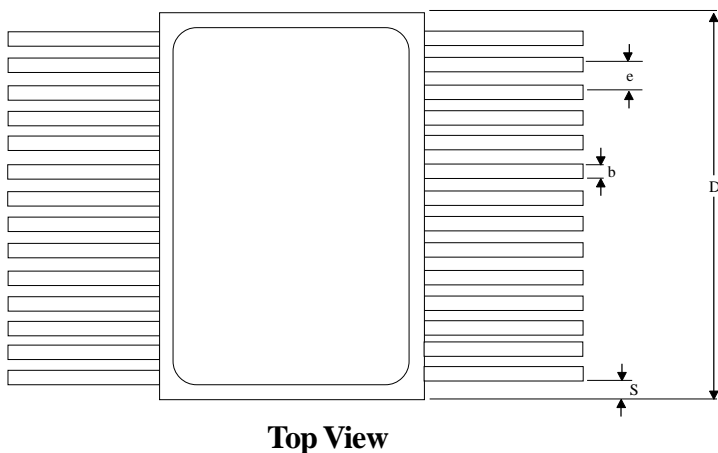

SYMBOL	SMD SPECIFICATIONS	
	MIN	MAX
A	0.090	0.130
b	0.015	0.019
c	0.004	0.009
D	---	0.740
E	0.380	0.420
E2	0.180	---
E3	0.030	---
e	0.050 BSC	
L	0.250	0.370
Q	0.026	0.045
S	0.000	0.045

**NOTE:** These dimensions are per the SMD. ASI's package dimensional limits may differ, but they will be within the SMD limits.

\* All measurements are in inches.



**MECHANICAL DEFINITIONS\***

ASI Case #500 (Package Designator DCJ)

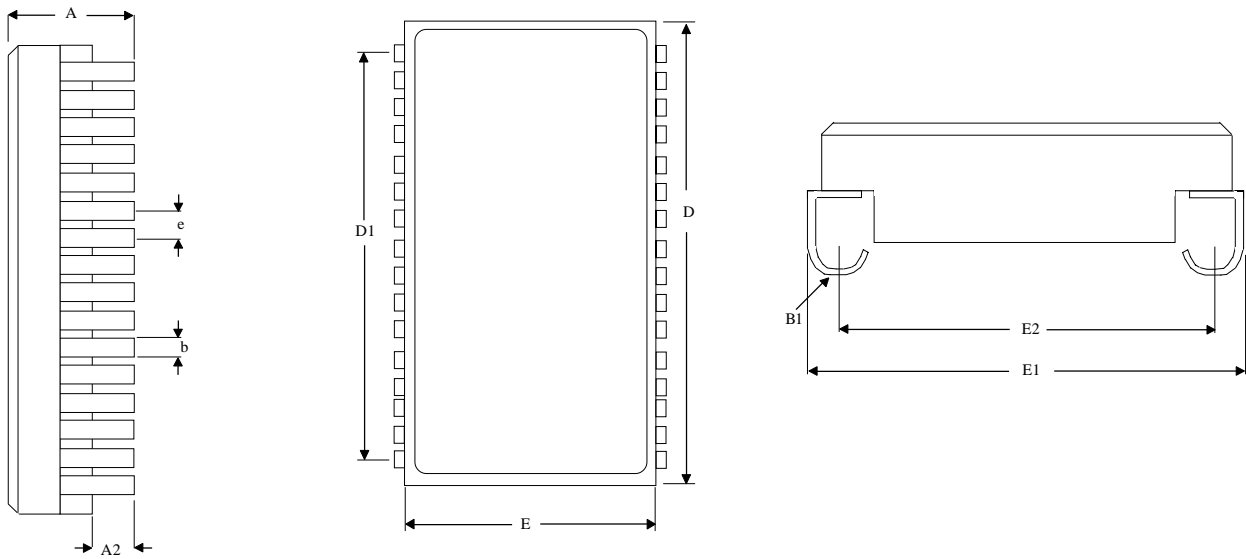

SYMBOL	ASI SPECIFICATIONS	
	MIN	MAX
A	0.132	0.144
A2	0.026	0.036
B1	0.030	0.040
b	0.015	0.019
D	0.712	0.728
D1	0.640	0.660
E	0.405	0.415
E1	0.435	0.445
E2	0.360	0.380
e	0.045	0.055

\* All measurements are in inches.



**ORDERING INFORMATION**

EXAMPLE: MT5C2568CW-25L/XT

EXAMPLE: MT5C2568ECW-15L/IT

Device Number	Package Type	Speed ns	Options**	Process
MT5C2568	C	-12	L	/*
MT5C2568	CW	-12	L	/*
MT5C2568	C	-15	L	/*
MT5C2568	CW	-15	L	/*
MT5C2568	C	-20	L	/*
MT5C2568	CW	-20	L	/*
MT5C2568	C	-25	L	/*
MT5C2568	CW	-25	L	/*
MT5C2568	C	-35	L	/*
MT5C2568	CW	-35	L	/*
MT5C2568	C	-45	L	/*
MT5C2568	CW	-45	L	/*
MT5C2568	C	-55	L	/*
MT5C2568	CW	-55	L	/*
MT5C2568	C	-70	L	/*
MT5C2568	CW	-70	L	/*
MT5C2568	CW	-100	L	/*

Device Number	Package Type	Speed ns	Options**	Process
MT5C2568	EC	-12	L	/*
MT5C2568	ECW	-12	L	/*
MT5C2568	EC	-15	L	/*
MT5C2568	ECW	-15	L	/*
MT5C2568	EC	-20	L	/*
MT5C2568	ECW	-20	L	/*
MT5C2568	EC	-25	L	/*
MT5C2568	ECW	-25	L	/*
MT5C2568	EC	-35	L	/*
MT5C2568	ECW	-35	L	/*
MT5C2568	EC	-45	L	/*
MT5C2568	ECW	-45	L	/*
MT5C2568	EC	-55	L	/*
MT5C2568	ECW	-55	L	/*
MT5C2568	EC	-70	L	/*
MT5C2568	ECW	-70	L	/*
MT5C2568	ECW	-100	L	/*

EXAMPLE: MT5C2568F-55/XT

EXAMPLE: MT5C2568DCJ-70L/IT

Device Number	Package Type	Speed ns	Options**	Process
MT5C2568	F	-12	L	/*
MT5C2568	F	-15	L	/*
MT5C2568	F	-20	L	/*
MT5C2568	F	-25	L	/*
MT5C2568	F	-35	L	/*
MT5C2568	F	-45	L	/*
MT5C2568	F	-55	L	/*
MT5C2568	F	-70	L	/*
MT5C2568	F	-100	L	/*

Device Number	Package Type	Speed ns	Options**	Process
MT5C2568	DCJ	-12	L	/*
MT5C2568	DCJ	-15	L	/*
MT5C2568	DCJ	-20	L	/*
MT5C2568	DCJ	-25	L	/*
MT5C2568	DCJ	-35	L	/*
MT5C2568	DCJ	-45	L	/*
MT5C2568	DCJ	-55	L	/*
MT5C2568	DCJ	-70	L	/*

**\*AVAILABLE PROCESSES**

IT = Industrial Temperature Range  
 XT = Extended Temperature Range  
 883C = Full Military Processing

-40°C to +85°C  
 -55°C to +125°C  
 -55°C to +125°C

*12ns offered in IT only*

**\*\*DEFINITION OF OPTIONS**

2V Data Retention / Low Power

L



**ASI TO DSCC PART NUMBER  
CROSS REFERENCE\***

**ASI Package Designator C & CW**

**ASI Package Designator EC & ECW**

<b>ASI Part #</b>
MT5C2568C-20/883C
MT5C2568C-25/883C
MT5C2568C-35/883C
MT5C2568C-45/883C
MT5C2568C-55/883C
MT5C2568C-70/883C
MT5C2568CW-20/883C
MT5C2568CW-25/883C
MT5C2568CW-35/883C
MT5C2568CW-45/883C
MT5C2568CW-55/883C
MT5C2568CW-70/883C
MT5C2568CW-100/883C

<b>SMD Part #</b>
5962-8866207NX
5962-8866206NX
5962-8866205NX
5962-8866204NX
5962-8866203NX
5962-8866202NX
5962-8866207XX
5962-8866206XX
5962-8866205XX
5962-8866204XX
5962-8866203XX
5962-8866202XX
5962-8866201XX

<b>ASI Part #</b>
MT5C2568EC-20/883C
MT5C2568EC-25/883C
MT5C2568EC-35/883C
MT5C2568EC-45/883C
MT5C2568EC-55/883C
MT5C2568EC-70/883C
MT5C2568ECW-20/883C
MT5C2568ECW-25/883C
MT5C2568ECW-35/883C
MT5C2568ECW-45/883C
MT5C2568ECW-55/883C
MT5C2568ECW-70/883C
MT5C2568ECW-100/883C

<b>SMD Part #</b>
5962-8866207UX
5962-8866206UX
5962-8866205UX
5962-8866204UX
5962-8866203UX
5962-8866202UX
5962-8866207YX
5962-8866206YX
5962-8866205YX
5962-8866204YX
5962-8866203YX
5962-8866202YX
5962-8866201YX

**ASI Package Designator F**

<b>ASI Part #</b>
MT5C2568F-20/883C
MT5C2568F-25/883C
MT5C2568F-35/883C
MT5C2568F-45/883C
MT5C2568F-55/883C
MT5C2568F-70/883C
MT5C2568F-100/883C

<b>SMD Part #</b>
5962-8866207TX
5962-8866206TX
5962-8866205TX
5962-8866204TX
5962-8866203TX
5962-8866202TX
5962-8866201TX

\* ASI part number is for reference only. Orders received referencing the SMD part number will be processed per the SMD.