

| REVISIONS |                             |          |        |
|-----------|-----------------------------|----------|--------|
| REV       | ECN, ERN NO.                | DATE     | APPRD. |
| A         | PRODUCT DRAWING (EAR 12927) | MAR07/06 | K.L.   |

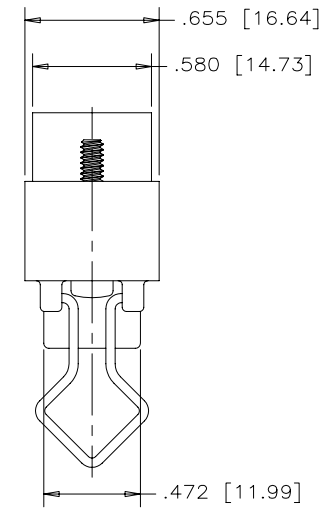
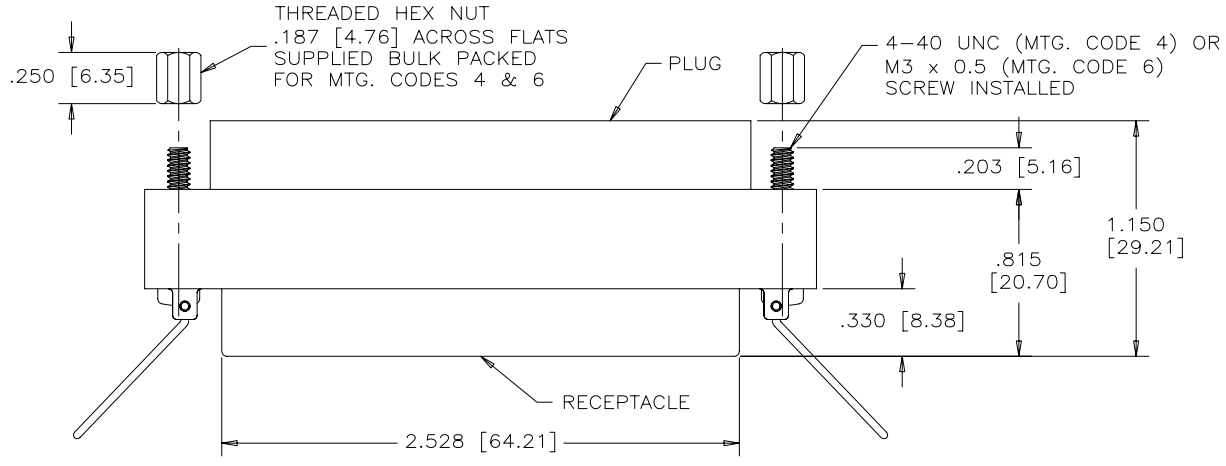
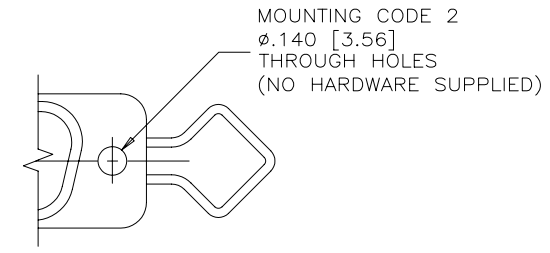
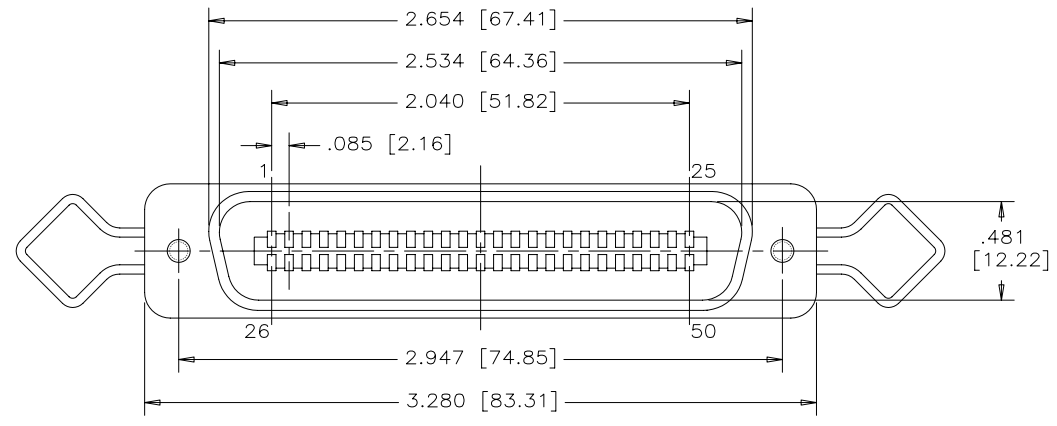

**ORDERING CODE:**

PART NUMBER F C E 5 7 - 0 9 5 0 0 - 4 1 0

SERIES \_\_\_\_\_

STYLE \_\_\_\_\_

09=ADAPTER

NUMBER OF CONTACTS \_\_\_\_\_

MODIFIER \_\_\_\_\_

0=STANDARD

MOUNTING OPTION \_\_\_\_\_

2=.140 [3.56] DIA MTG. HOLE (NO SCREWS OR HEX NUTS)

4=#4-40 UNC THREADED SCREW & HEX NUT

6=M3 x 0.5 THREADED SCREW & HEX NUT

MODIFIER  
0=STANDARD

CAPACITANCE

- D=50 pF
- B=100 pF
- 0=180 pF
- F=330 pF
- 1=470 pF
- 3=820 pF
- 5=1000 pF
- 7=1200 pF
- E=2200 pF
- 9=5600 pF
- 8=47000 pF
- N=NO FILTERS

**ELECTRICAL DATA:**

CSA/UL RATING: 250 VDC, 1A MAX.

REFER TO AMPHENOL CATALOGUE FOR FILTER PERFORMANCE CHARACTERISTICS

**MATERIALS:**

ALL MATERIALS ARE RoHS COMPLIANT

**SHELL:**

ALUMINUM DIECAST, NICKEL PLATED.

**CONTACTS:**

PHOSPHOR BRONZE, 30u" [0.76 MICRONS] MIN GOLD PLATED OVER 50u" [1.27 MICRONS] MIN NICKEL ON CONTACT MATING AREAS.

**INSERT:**

HIGH STRENGTH THERMOPLASTIC POLYESTER FLAMMABILITY RATING UL 94V-0, BLACK.

|                               |           |       |                   |
|-------------------------------|-----------|-------|-------------------|
| DRAWN                         | A.CHENG   | DATE  | MAR07/06          |
| DESIGNED                      |           |       |                   |
| CHECKED                       | K.LAMBIE  | DATE  | MAR07/06          |
| I. E. APPRD.                  |           |       |                   |
| Q. A. APPRD.                  |           |       |                   |
| DWG. APPRD.                   |           |       |                   |
| ENG. REL. NO.                 |           | DWG   | DRAWING NO.       |
| REF.                          | EAR 12927 | C     | P-FCE57-09500-XX0 |
| DIMENSIONS ARE IN INCHES [mm] |           | SCALE | 2/1               |
| CODE ID. NO.                  |           | WT.   |                   |
| 03554                         |           | SURF. |                   |
|                               |           | SHEET | 1 OF 1            |

**Amphenol Canada Corp.**

FCE57 FILTERED MICRO-RIBBON CONNECTOR, PLUG/RECEPTACLE ADAPTER, 50 SIZE, LATCH SPRINGS, RoHS COMPLIANT

THIS DOCUMENT CONTAINS PROPRIETARY INFORMATION AND SUCH INFORMATION MAY NOT BE DISCLOSED TO OTHERS FOR ANY PURPOSE OR USED FOR MANUFACTURING PURPOSES WITHOUT WRITTEN PERMISSION FROM AMPHENOL CANADA CORP.