

**Features**

- Fast Read Access Time - 100 ns
- Low Power CMOS Operation
  - 100  $\mu$ A max. Standby
  - 25 mA max. Active at 5 MHz (AT27C010L)
  - 40 mA max. Active at 5 MHz (AT27C010)
- Wide Selection of JEDEC Standard Packages Including OTP
  - 32-Lead 600-mil Cerdip and OTP Plastic DIP, SOIC or TSOP
  - 32-Pad LCC, 32-Lead JLCC and OTP PLCC
- 5 V  $\pm$  10% Supply
- High Reliability CMOS Technology
  - 2000 V ESD Protection
  - 200 mA Latchup Immunity
- Rapid Programming - 100  $\mu$ s/byte (typical)
- Two-line Control
- CMOS and TTL Compatible Inputs and Outputs
- Integrated Product Identification Code
- Full Military, Commercial and Industrial Temperature Ranges

**1 Megabit  
(128K x 8)  
UV  
Erasable  
CMOS  
EPROM**

4

**Description**

The AT27C010/L chip family is a low-power, high performance 1,048,576 bit Ultraviolet Erasable and Electrically Programmable Read Only Memory (EPROM) organized as 128K x 8 bits. They require only one 5 V power supply in normal read mode operation. Any byte can be accessed in less than 100 ns, eliminating the need for speed reducing WAIT states on high performance microprocessor systems.

Two power versions are offered. In read mode, the AT27C010 typically consumes 25 mA while the AT27C010L takes only 8 mA. Standby mode supply current for both parts is typically less than 10  $\mu$ A.

**Pin Configurations**

Pin Name	Function
A0-A16	Addresses
O0-O7	Outputs
CE	Chip Enable
OE	Output Enable
PGM	Program Strobe
NC	No Connect

CDIP, PDIP, SOIC Top

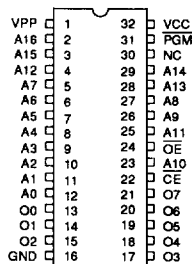

LCC, JLCC, PLCC Top

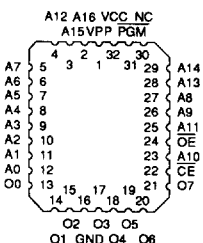

TSOP Top View  
Type 1

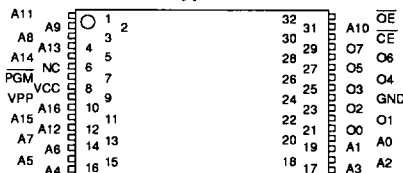

## Description (Continued)

The AT27C010/L comes in a choice of industry standard JEDEC-approved packages including: 32-pin ceramic DIP; 32-pad ceramic leadless chip carrier (LCC); 32-lead ceramic J-leaded chip carrier (JLCC); 32-lead one time programmable (OTP) plastic J-leaded chip carrier (PLCC); 32-pin OTP plastic gull wing small outline IC (SOIC); and 32-pin OTP thin small outline package (TSOP). All devices feature two line control ( $\overline{CE}$ ,  $\overline{OE}$ ) to give designers the flexibility to prevent bus contention.

With high density 128K byte storage capability, the AT27C010/L allow firmware to be stored reliably and to be accessed by the system without the delays of mass storage media.

Atmel's 27C010/L have additional features to ensure high quality and efficient production use. The Rapid Programming Algorithm reduces the time required to program the part and guarantees reliable programming. Programming time is typically only 100  $\mu\text{s}/\text{byte}$ . The Integrated Product Identification Code electronically identifies the device and manufacturer. This feature is used by industry standard programming equipment to select the proper programming algorithms and voltages.

## Erase Characteristics

The entire memory array of the AT27C010/L is erased (all outputs read as  $V_{OH}$ ) after exposure to ultraviolet light at a wavelength of 2537 $\text{\AA}$ . Complete erasure is assured after a minimum of 20 minutes exposure using 12,000  $\mu\text{W}/\text{cm}^2$  intensity lamps spaced one inch away from the chip. Minimum erase time for lamps at other intensity ratings can be calculated from the minimum integrated erasure dose of 15  $\text{W}\cdot\text{sec}/\text{cm}^2$ . To prevent unintentional erasure, an opaque label is recommended to cover the clear window on any UV erasable EPROM which will be subjected to continuous fluorescent indoor lighting or sunlight.

## Block Diagram

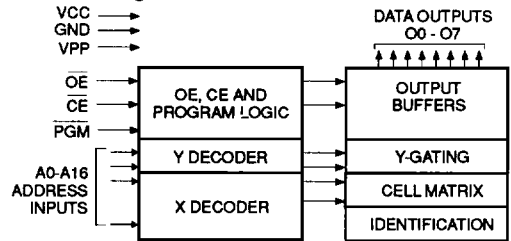

## Absolute Maximum Ratings\*

Temperature Under Bias .....	-55°C to +125°C
Storage Temperature .....	-65°C to +150°C
Voltage on Any Pin with Respect to Ground .....	-2.0 V to +7.0 V <sup>(1)</sup>
Voltage on A9 with Respect to Ground .....	-2.0 V to +14.0 V <sup>(1)</sup>
V <sub>PP</sub> Supply Voltage with Respect to Ground .....	-2.0 V to +14.0 V <sup>(1)</sup>
Integrated UV Erase Dose .....	7258 $\text{W}\cdot\text{sec}/\text{cm}^2$

\*NOTICE: Stresses beyond those listed under "Absolute Maximum Ratings" may cause permanent damage to the device. This is a stress rating only and functional operation of the device at these or any other conditions beyond those indicated in the operational sections of this specification is not implied. Exposure to absolute maximum rating conditions for extended periods may affect device reliability.

### Notes:

1. Minimum voltage is -0.6 V dc which may undershoot to -2.0 V for pulses of less than 20 ns. Maximum output pin voltage is  $V_{CC} + 0.75$  V dc which may overshoot to +7.0 V for pulses of less than 20 ns.

## Operating Modes

Mode \ Pin	$\overline{CE}$	$\overline{OE}$	PGM	Ai	V <sub>PP</sub>	V <sub>CC</sub>	Outputs
Read	V <sub>IL</sub>	V <sub>IL</sub>	X <sup>(1)</sup>	Ai	X	V <sub>CC</sub>	DOUT
Output Disable	X	V <sub>IH</sub>	X	X	X	V <sub>CC</sub>	High Z
Standby	V <sub>IH</sub>	X	X	X	X	V <sub>CC</sub>	High Z
Fast Program <sup>(2)</sup>	V <sub>IL</sub>	V <sub>IH</sub>	V <sub>IL</sub>	Ai	V <sub>PP</sub>	V <sub>CC</sub>	DIN
PGM Verify	V <sub>IL</sub>	V <sub>IL</sub>	V <sub>IH</sub>	Ai	V <sub>PP</sub>	V <sub>CC</sub>	DOUT
PGM Inhibit	V <sub>IH</sub>	X	X	X	V <sub>PP</sub>	V <sub>CC</sub>	High Z
Product Identification <sup>(4)</sup>	V <sub>IL</sub>	V <sub>IL</sub>	X	A9=V <sub>H</sub> <sup>(3)</sup> A0=V <sub>IH</sub> or V <sub>IL</sub> A1-A16=V <sub>IL</sub>	X	V <sub>CC</sub>	Identification Code

- Notes:
1. X can be V<sub>IL</sub> or V<sub>IH</sub>.
  2. Refer to Programming characteristics.
  3. V<sub>H</sub> = 12.0  $\pm$  0.5 V.

4. Two identifier bytes may be selected. All Ai inputs are held low (V<sub>IL</sub>), except A9 which is set to V<sub>H</sub> and A0 which is toggled low (V<sub>IL</sub>) to select the Manufacturer's Identification byte and high (V<sub>IH</sub>) to select the Device Code byte.

## D.C. and A.C. Operating Conditions for Read Operation

AT27C010 / AT27C010L						
		-10	-12	-15	-20	-25
Operating Temperature (Case)	Com.	0°C - 70°C	0°C - 70°C	0°C - 70°C	0°C - 70°C	0°C - 70°C
	Ind.		-40°C - 85°C	-40°C - 85°C	-40°C - 85°C	-40°C - 85°C
	Mil.		-55°C - 125°C	-55°C - 125°C	-55°C - 125°C	-55°C - 125°C
V <sub>CC</sub> Power Supply		5 V ± 5%	5 V ± 10%	5 V ± 10%	5 V ± 10%	5 V ± 10%

## D.C. and Operating Characteristics for Read Operation

4

Symbol	Parameter	Condition	Min	Max	Units	
I <sub>LI</sub>	Input Load Current	V <sub>IN</sub> = -0.1 V to V <sub>CC</sub> +1 V		5	μA	
I <sub>LO</sub>	Output Leakage Current	V <sub>OUT</sub> = -0.1 V to V <sub>CC</sub> +0.1 V		10	μA	
I <sub>PP1</sub> (2)	V <sub>PP</sub> (1) Read/Standby Current	V <sub>PP</sub> = 3.8 to V <sub>CC</sub> +0.3 V		10	μA	
I <sub>SB</sub>	V <sub>CC</sub> (1) Standby Current	I <sub>SB1</sub> (CMOS), CE = V <sub>CC</sub> -0.3 to V <sub>CC</sub> +1.0 V		100	μA	
		I <sub>SB2</sub> (TTL), CE = 2.0 to V <sub>CC</sub> +1.0 V		1	mA	
I <sub>CC</sub>	V <sub>CC</sub> Active Current	f = 5 MHz, I <sub>OUT</sub> = 0 mA, CE = V <sub>IL</sub>	AT27C010L	Com.	25	mA
				Ind.,Mil.	30	mA
		AT27C010	Com.	40	mA	
			Ind.,Mil.	50	mA	
V <sub>IL</sub>	Input Low Voltage		-0.6	0.8	V	
V <sub>IH</sub>	Input High Voltage		2.0	V <sub>CC</sub> +0.75	V	
V <sub>OL</sub>	Output Low Voltage	I <sub>OL</sub> = 2.1 mA		.45	V	
V <sub>OH</sub>	Output High Voltage	I <sub>OH</sub> = -100 μA		V <sub>CC</sub> -0.3	V	
		I <sub>OH</sub> = -2.5 mA		3.5	V	
		I <sub>OH</sub> = -400 μA		2.4	V	

Notes: 1. V<sub>CC</sub> must be applied simultaneously or before V<sub>PP</sub>, and removed simultaneously or after V<sub>PP</sub>.  
 2. V<sub>PP</sub> may be connected directly to V<sub>CC</sub>, except during programming. The supply current would then be the sum of I<sub>CC</sub> and I<sub>PP</sub>.

## A.C. Characteristics for Read Operation

			AT27C010 / AT27C010L										Units
Symbol	Parameter	Condition	-10		-12		-15		-20		-25		
			Min	Max	Min	Max	Min	Max	Min	Max	Min	Max	
t <sub>ACC</sub> (3)	Address to Output Delay	CE = OE = V <sub>IL</sub>	Com.		100	120	150	200	250				ns
			Ind.,Mil.			120	150	200	250				ns
t <sub>CE</sub> (2)	CE to Output Delay	OE = V <sub>IL</sub>	100	120	150	200	250						ns
t <sub>OE</sub> (2,3)	OE to Output Delay	CE = V <sub>IL</sub>	35	40	40	70	100						ns
t <sub>DF</sub> (4,5)	OE High to Output Float	CE = V <sub>IL</sub>	30	35	40	55	60						ns
t <sub>OH</sub>	Output Hold from Address, CE or OE, whichever occurred first	CE = OE = V <sub>IL</sub>	0	0	0	0	0						ns

Notes: 2, 3, 4, 5. - see AC Waveforms for Read Operation.



## A.C. Waveforms for Read Operation <sup>(1)</sup>

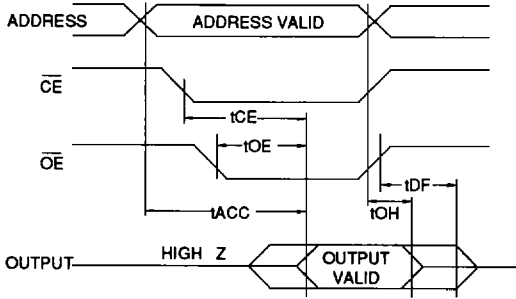

**Notes:**

1. Timing measurement references are 0.8 V and 2.0 V. Input AC driving levels are 0.45 V and 2.4 V, unless otherwise specified.
2.  $\overline{OE}$  may be delayed up to  $t_{CE-tOE}$  after the falling edge of  $\overline{CE}$  without impact on  $t_{CE}$ .
3.  $\overline{OE}$  may be delayed up to  $t_{ACC-tOE}$  after the address is valid without impact on  $t_{ACC}$ .
4. This parameter is only sampled and is not 100% tested.
5. Output float is defined as the point when data is no longer driven.

## Input Test Waveforms and Measurement Levels

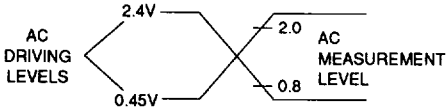

$t_R, t_F < 20$  ns (10% to 90%)

## Output Test Load

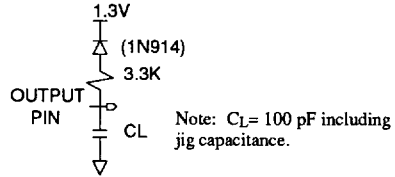

## Pin Capacitance ( $f = 1$ MHz, $T = 25^\circ\text{C}$ ) <sup>(1)</sup>

	Typ	Max	Units	Conditions
$C_{IN}$	4	8	pF	$V_{IN} = 0$ V
$C_{OUT}$	8	12	pF	$V_{OUT} = 0$ V

Notes: 1. Typical values for nominal supply voltage. This parameter is only sampled and is not 100% tested.

## Programming Waveforms <sup>(1)</sup>

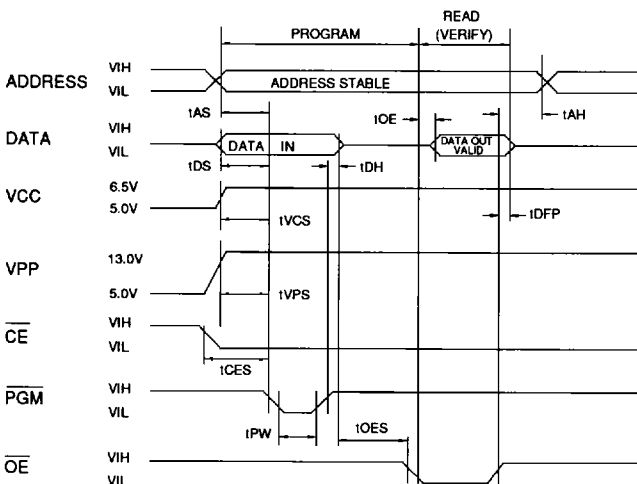

**Notes:**

1. The Input Timing Reference is 0.8 V for  $V_{IL}$  and 2.0 V for  $V_{IH}$ .
2.  $t_{OE}$  and  $t_{DFP}$  are characteristics of the device but must be accommodated by the programmer.
3. When programming the AT27C010/L a 0.1- $\mu\text{F}$  capacitor is required across  $V_{PP}$  and ground to suppress spurious voltage transients.

**D.C. Programming Characteristics**

$T_A = 25 \pm 5^\circ\text{C}$ ,  $V_{CC} = 6.5 \pm 0.25\text{ V}$ ,  $V_{PP} = 13.0 \pm 0.25\text{ V}$

Sym- bol	Parameter	Test Conditions	Limits		Units
			Min	Max	
I <sub>L</sub>	Input Load Current	$V_{IN}=V_{IL}, V_{IH}$		10	$\mu\text{A}$
V <sub>IL</sub>	Input Low Level	(All Inputs)	-0.6	0.8	V
V <sub>IH</sub>	Input High Level		2.0	$V_{CC}+1$	V
V <sub>OL</sub>	Output Low Volt.	$I_{OL}=2.1\text{ mA}$		.45	V
V <sub>OH</sub>	Output High Volt.	$I_{OH}=400\ \mu\text{A}$	2.4		V
I <sub>CC2</sub>	V <sub>CC</sub> Supply Current (Program and Verify)			40	mA
I <sub>PP2</sub>	V <sub>PP</sub> Supply Current	$\overline{CE}=\overline{PGM}=V_{IL}$		20	mA
V <sub>ID</sub>	A9 Product Identification Voltage		11.5	12.5	V

**A.C. Programming Characteristics**

$T_A = 25 \pm 5^\circ\text{C}$ ,  $V_{CC} = 6.5 \pm 0.25\text{ V}$ ,  $V_{PP} = 13.0 \pm 0.25\text{ V}$

Sym- bol	Parameter	Test Conditions* (see Note 1)	Limits		Units
			Min	Max	
t <sub>AS</sub>	Address Setup Time		2		$\mu\text{s}$
t <sub>CES</sub>	$\overline{CE}$ Setup Time		2		$\mu\text{s}$
t <sub>OES</sub>	$\overline{OE}$ Setup Time		2		$\mu\text{s}$
t <sub>DS</sub>	Data Setup Time		2		$\mu\text{s}$
t <sub>AH</sub>	Address Hold Time		0		$\mu\text{s}$
t <sub>DH</sub>	Data Hold Time		2		$\mu\text{s}$
t <sub>DFP</sub>	$\overline{OE}$ High to Out- put Float Delay (Note 2)		0	130	ns
t <sub>VPS</sub>	V <sub>PP</sub> Setup Time		2		$\mu\text{s}$
t <sub>VCS</sub>	V <sub>CC</sub> Setup Time		2		$\mu\text{s}$
t <sub>PW</sub>	PGM Program Pulse Width (Note 3)		95	105	$\mu\text{s}$
t <sub>OE</sub>	Data Valid from $\overline{OE}$			150	ns

\*A.C. Conditions of Test:

- Input Rise and Fall Times (10% to 90%) ..... 20 ns
- Input Pulse Levels ..... 0.45 V to 2.4 V
- Input Timing Reference Level ..... 0.8 V to 2.0 V
- Output Timing Reference Level ..... 0.8 V to 2.0 V

Notes:

1. V<sub>CC</sub> must be applied simultaneously or before V<sub>pp</sub> and removed simultaneously or after V<sub>pp</sub>.
2. This parameter is only sampled and is not 100% tested. Output Float is defined as the point where data is no longer driven — see timing diagram.
3. Program Pulse width tolerance is 100  $\mu\text{s} \pm 5\%$ .

**Atmel's 27C010/L Integrated Product Identification Code**

Codes	Pins									Hex Data
	A0	O7	O6	O5	O4	O3	O2	O1	O0	
Manufacturer	0	0	0	0	1	1	1	1	0	1E
Device Type	1	0	0	0	0	0	1	0	1	O5

**Rapid Programming Algorithm**

A 100  $\mu\text{s}$  PGM pulse width is used to program. The address is set to the first location. V<sub>CC</sub> is raised to 6.5 V and V<sub>PP</sub> is raised to 13.0 V. Each address is first programmed with one 100  $\mu\text{s}$  PGM pulse without verification. Then a verification / reprogramming loop is executed for each address. In the event a byte fails to pass verification, up to 10 successive 100  $\mu\text{s}$  pulses are applied with a verification after each pulse. If the byte fails to verify after 10 pulses have been applied, the part is considered failed. After the byte verifies properly, the next address is selected until all have been checked. V<sub>PP</sub> is then lowered to 5.0 V and V<sub>CC</sub> to 5.0 V. All bytes are read again and compared with the original data to determine if the device passes or fails.

4

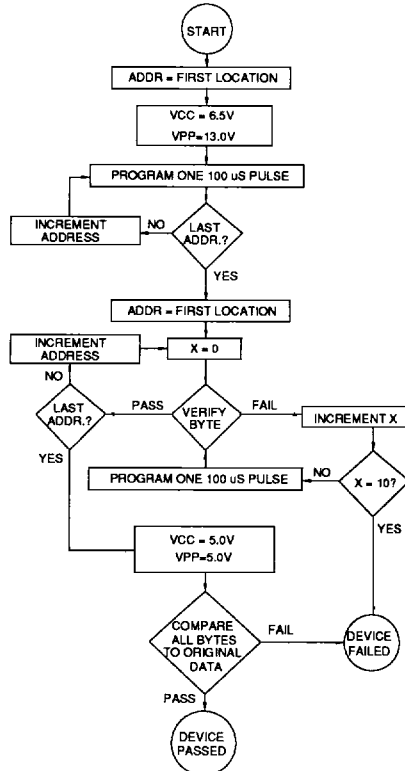



## Ordering Information

tACC (ns)	Icc (mA)		Ordering Code	Package	Operation Range
	Active	Standby			
100	40	0.1	AT27C010-10DC AT27C010-10KC AT27C010-10LC	32DW6 32KW 32LW	Commercial (0°C to 70°C)
120	40	0.1	AT27C010-12DC AT27C010-12JC AT27C010-12KC AT27C010-12LC AT27C010-12PC AT27C010-12RC	32DW6 32J 32KW 32LW 32P6 32R	Commercial (0°C to 70°C)
120	50	0.1	AT27C010-12DI AT27C010-12JI AT27C010-12KI AT27C010-12LI AT27C010-12PI AT27C010-12RI	32DW6 32J 32KW 32LW 32P6 32R	Industrial (-40°C to 85°C)
			AT27C010-12DM AT27C010-12KM AT27C010-12LM	32DW6 32KW 32LW	Military (-55°C to 125°C)
			AT27C010-12DM/883 AT27C010-12KM/883 AT27C010-12LM/883	32DW6 32KW 32LW	Military/883C Class B, Fully Compliant (-55°C to 125°C)
150	40	0.1	AT27C010-15DC AT27C010-15JC AT27C010-15KC AT27C010-15LC AT27C010-15PC AT27C010-15RC	32DW6 32J 32KW 32LW 32P6 32R	Commercial (0°C to 70°C)
150	50	0.1	AT27C010-15DI AT27C010-15JI AT27C010-15KI AT27C010-15LI AT27C010-15PI AT27C010-15RI	32DW6 32J 32KW 32LW 32P6 32R	Industrial (-40°C to 85°C)
			AT27C010-15DM AT27C010-15KM AT27C010-15LM	32DW6 32KW 32LW	Military (-55°C to 125°C)
			AT27C010-15DM/883 AT27C010-15KM/883 AT27C010-15LM/883	32DW6 32KW 32LW	Military/883C Class B, Fully Compliant (-55°C to 125°C)
200	40	0.1	AT27C010-20DC AT27C010-20JC AT27C010-20KC AT27C010-20LC AT27C010-20PC AT27C010-20RC	32DW6 32J 32KW 32LW 32P6 32R	Commercial (0°C to 70°C)

## Ordering Information

tACC (ns)	Icc (mA)		Ordering Code	Package	Operation Range
	Active	Standby			
200	50	0.1	AT27C010-20DI AT27C010-20JI AT27C010-20KI AT27C010-20LI AT27C010-20PI AT27C010-20RI	32DW6 32J 32KW 32LW 32P6 32R	Industrial (-40°C to 85°C)
			AT27C010-20DM AT27C010-20KM AT27C010-20LM	32DW6 32KW 32LW	Military (-55°C to 125°C)
			AT27C010-20DM/883 AT27C010-20KM/883 AT27C010-20LM/883	32DW6 32KW 32LW	Military/883C Class B, Fully Compliant (-55°C to 125°C)
250	40	0.1	AT27C010-25DC AT27C010-25JC AT27C010-25KC AT27C010-25LC AT27C010-25PC	32DW6 32J 32KW 32LW 32P6	Commercial (0°C to 70°C)
250	50	0.1	AT27C010-25DI AT27C010-25JI AT27C010-25KI AT27C010-25LI AT27C010-25PI	32DW6 32J 32KW 32LW 32P6	Industrial (-40°C to 85°C)
			AT27C010-25DM AT27C010-25KM AT27C010-25LM	32DW6 32KW 32LW	Military (-55°C to 125°C)
			AT27C010-25DM/883 AT27C010-25KM/883 AT27C010-25LM/883	32DW6 32KW 32LW	Military/883C Class B, Fully Compliant (-55°C to 125°C)
120	50	0.1	5962-89614 06 M XX 5962-89614 06 M YX	32DW6 32LW	Military/883C Class B, Fully Compliant (-55°C to 125°C)
150	50	0.1	5962-89614 05 M XX 5962-89614 05 M YX	32DW6 32LW	Military/883C Class B, Fully Compliant (-55°C to 125°C)
170	50	0.1	5962-89614 04 M XX 5962-89614 04 M YX	32DW6 32LW	Military/883C Class B, Fully Compliant (-55°C to 125°C)
200	50	0.1	5962-89614 03 M XX 5962-89614 03 M YX	32DW6 32LW	Military/883C Class B, Fully Compliant (-55°C to 125°C)
250	50	0.1	5962-89614 02 M XX 5962-89614 02 M YX	32DW6 32LW	Military/883C Class B, Fully Compliant (-55°C to 125°C)
300	50	0.1	5962-89614 01 M XX 5962-89614 01 M YX	32DW6 32LW	Military/883C Class B, Fully Compliant (-55°C to 125°C)



## Ordering Information

t <sub>ACC</sub> (ns)	I <sub>CC</sub> (mA)		Ordering Code	Package	Operation Range
	Active	Standby			
120	40	0.1	AT27C010-12TC	32T	Commercial (0° to 70°C)
150	40	0.1	AT27C010-15TC	32T	Commercial (0° to 70°C)

Package Type	
<b>32DW6</b>	32 Lead, 0.600" Wide, Windowed, Ceramic Dual Inline Package (Cerdip)
<b>32J</b>	32 Lead, Plastic J-Leaded Chip Carrier OTP (PLCC)
<b>32KW</b>	32 Lead, Windowed, Ceramic J-Leaded Chip Carrier (JLCC)
<b>32LW</b>	32 Pad, Windowed, Ceramic Leadless Chip Carrier (LCC)
<b>32R</b>	32 Lead, 0.450" Wide, Plastic Gull Wing Small Outline OTP (SOIC)
<b>32T</b>	32 Lead, Plastic Thin Small Outline Package OTP (TSOP)



## Ordering Information

tACC (ns)	Icc (mA)		Ordering Code	Package	Operation Range
	Active	Standby			
100	40	0.1	AT27C010L-10DC AT27C010L-10KC AT27C010L-10LC	32DW6 32KW 32LW	Commercial (0°C to 70°C)
120	25	0.1	AT27C010L-12DC AT27C010L-12JC AT27C010L-12KC AT27C010L-12LC AT27C010L-12PC AT27C010L-12RC	32DW6 32J 32KW 32LW 32P6 32R	Commercial (0°C to 70°C)
120	30	0.1	AT27C010L-12DI AT27C010L-12JI AT27C010L-12KI AT27C010L-12LI AT27C010L-12PI AT27C010L-12RI	32DW6 32J 32KW 32LW 32P6 32R	Industrial (-40°C to 85°C)
			AT27C010L-12DM AT27C010L-12KM AT27C010L-12LM	32DW6 32KW 32LW	Military (-55°C to 125°C)
			AT27C010L-12DM/883 AT27C010L-12KM/883 AT27C010L-12LM/883	32DW6 32KW 32LW	Military/883C Class B, Fully Compliant (-55°C to 125°C)
150	25	0.1	AT27C010L-15DC AT27C010L-15JC AT27C010L-15LC AT27C010L-15KC AT27C010L-15PC AT27C010L-15RC	32DW6 32J 32LW 32KW 32P6 32R	Commercial (0°C to 70°C)
150	30	0.1	AT27C010L-15DI AT27C010L-15JI AT27C010L-15KI AT27C010L-15LI AT27C010L-15PI AT27C010L-15RI	32DW6 32J 32KW 32LW 32P6 32R	Industrial (-40°C to 85°C)
			AT27C010L-15DM AT27C010L-15KM AT27C010L-15LM	32DW6 32KW 32LW	Military (-55°C to 125°C)
			AT27C010L-15DM/883 AT27C010L-15KM/883 AT27C010L-15LM/883 AT27C010L-17LI AT27C010L-17PI AT27C010L-17SI	32DW6 32KW 32LW 32LW 32P6 32S	Military/883C Class B, Fully Compliant (-55°C to 125)
200	25	0.1	AT27C010L-20DC AT27C010L-20JC AT27C010L-20KC AT27C010L-20LC AT27C010L-20PC AT27C010L-20RC	32DW6 32J 32KW 32LW 32P6 32R	Commercial (0°C to 70°C)



## Ordering Information

t <sub>acc</sub> (ns)	I <sub>cc</sub> (mA)		Ordering Code	Package	Operation Range
	Active	Standby			
200	30	0.1	AT27C010L-20DI AT27C010L-20JI AT27C010L-20KI AT27C010L-20LI AT27C010L-20PI AT27C010L-20RI	32DW6 32J 32KW 32LW 32P6 32R	Industrial (-40°C to 85°C)
			AT27C010L-20DM AT27C010L-20KM AT27C010L-20LM	32DW6 32KW 32LW	Military (-55°C to 125°C)
			AT27C010L-20DM/883 AT27C010L-20KM/883 AT27C010L-20LM/883	32DW6 32KW 32LW	Military/883C Class B, Fully Compliant (-55°C to 125°C)
250	25	0.1	AT27C010L-25DC AT27C010L-25JC AT27C010L-25KC AT27C010L-25LC AT27C010L-25PC	32DW6 32J 32KW 32LW 32P6	Commercial (0°C to 70°C)
250	30	0.1	AT27C010L-25DI AT27C010L-25JI AT27C010L-25KI AT27C010L-25LI AT27C010L-25PI	32DW6 32J 32KW 32LW 32P6	Industrial (-40°C to 85°C)
			AT27C010L-25DM AT27C010L-25KM AT27C010L-25LM	32DW6 32KW 32LW	Military (-55°C to 125°C)
			AT27C010L-25DM/883 AT27C010L-25KM/883 AT27C010L-25LM/883	32DW6 32KW 32LW	Military/883C Class B, Fully Compliant (-55°C to 125°C)

t <sub>acc</sub> (ns)	I <sub>cc</sub> (mA)		Ordering Code	Package	Operation Range
	Active	Standby			
120	25	0.1	AT27C010L-12TC	32T	Commercial (0° to 70°C)
150	25	0.1	AT27C010L-15TC	32T	Commercial (0° to 70°C)

<b>Package Type</b>	
<b>32DW6</b>	32 Lead, 0.600" Wide, Windowed, Ceramic Dual Inline Package (Cerdip)
<b>32J</b>	32 Lead, Plastic J-Leaded Chip Carrier OTP (PLCC)
<b>32KW</b>	32 Lead, Windowed, Ceramic J-Leaded Chip Carrier (JLCC)
<b>32LW</b>	32 Pad, Windowed, Ceramic Leadless Chip Carrier (LCC)
<b>32P6</b>	32 Lead, 0.600" Wide, Plastic Dual Inline Package OTP (PDIP)
<b>32R</b>	32 Lead, 0.450" Wide, Plastic Gull Wing Small Outline OTP (SOIC)
<b>32T</b>	32 Lead, Plastic Thin Small Outline Package OTP (TSOP)

