



PRELIMINARY

CYM1861V33

2,048K x 32 3.3V Static RAM Module

Features

- High-density 3.3V 64-megabit SRAM module
- 32-bit Standard Footprint supports densities from 16K x 32 through 2M x 32
- High-speed SRAMs
 - Access time of 20 ns
- 72 pins
- Available in SIMM format

Functional Description

The CYM1861V33 is a high-performance 3.3V 64-megabit static RAM module organized as 2,048K words by 32 bits. This module is constructed from sixteen 1,024K x 4 SRAMs in SOJ

packages mounted on an epoxy laminate substrate. Four chip selects are used to independently enable the four bytes. Reading or writing can be executed on individual bytes or any combination of multiple bytes through proper use of selects.

The CYM1861V33 is designed for use with standard 72-pin SIMM sockets. The pinout is downward compatible with the 64-pin JEDEC SIMM module family (CYM1821, CYM1831, CYM1836, and CYM1841). Thus, a single motherboard design can be used to accommodate memory depth ranging from 16K words (CYM1821) to 2,048K words (CYM1861V33). The CYM1861V33 is offered in vertical SIMM configuration and is available with tin-lead edge contacts.

Presence detect pins (PD₀-PD₃) are used to identify module memory density in applications where modules with alternate word depths can be interchanged.

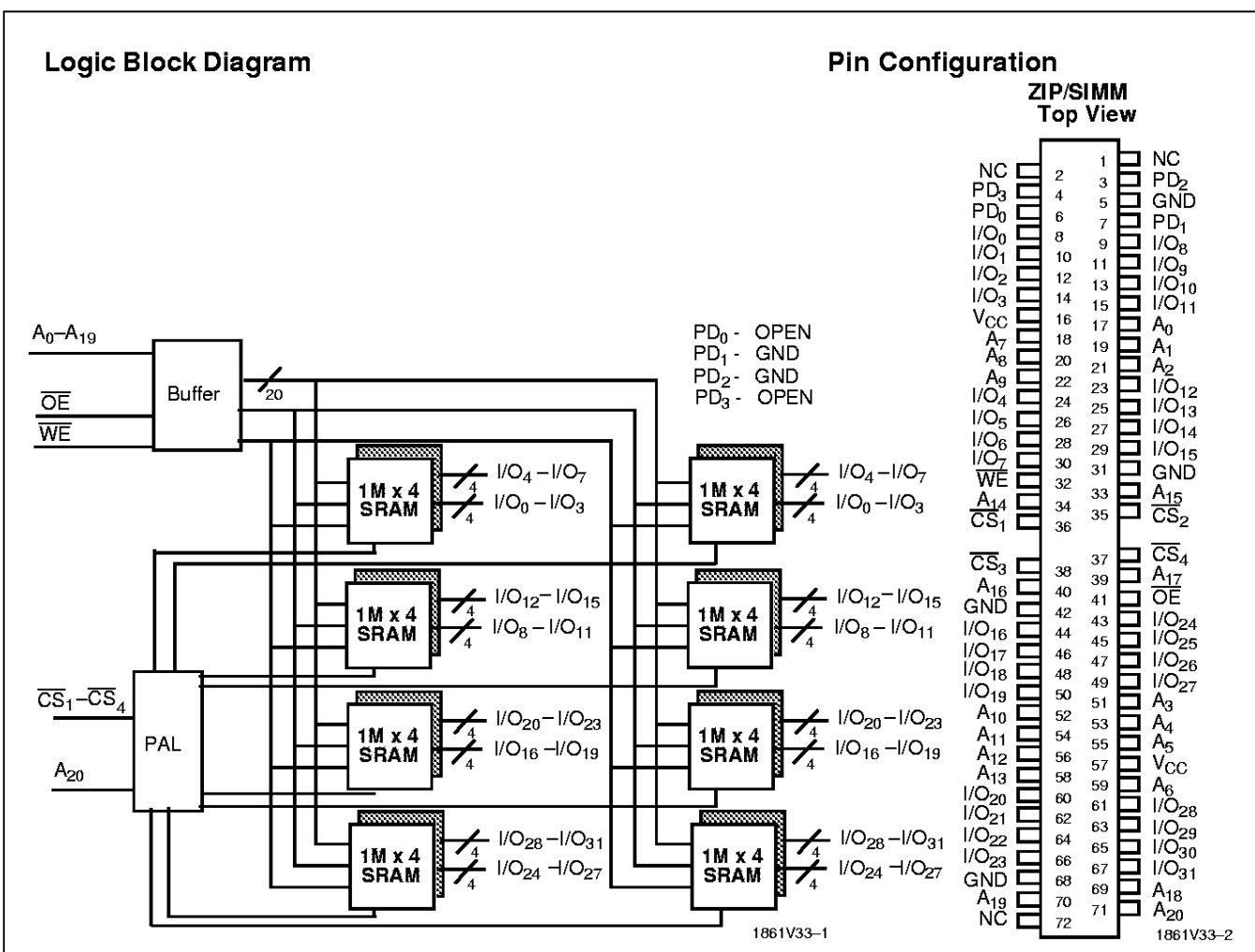

Selection Guide

	1861V33-20	1861V33-25
Maximum Access Time (ns)	25	35
Maximum Operating Current (mA)	2400	2400
Maximum Standby Current (mA)	1050	1050

Maximum Ratings

(Above which the useful life may be impaired. For user guidelines, not tested.)

Storage Temperature -55°C to +125°C

Ambient Temperature with Power Applied -10°C to +85°C

Supply Voltage to Ground Potential -0.5V to +4.6V

DC Voltage Applied to Outputs in High Z State -0.5V to +V_{CC}

DC Input Voltage -0.5V to +4.6V

Operating Range

Range	Ambient Temperature	V _{CC}
Commercial	0°C to +70°C	3.3 V + 10% -5%

Electrical Characteristics Over the Operating Range

Parameter	Description	Test Conditions	Min.	Max.	Unit
V _{OH}	Output HIGH Voltage	V _{CC} = Min., I _{OH} = -4.0 mA	2.4		V
V _{OL}	Output LOW Voltage	V _{CC} = Min., I _{OL} = 4.0 mA		0.4	V
V _{IH}	Input HIGH Voltage		2.2	V _{CC} + 0.3	V
V _{IL}	Input LOW Voltage		-0.3V	0.8	V
I _{Ix}	Input Load Current	GND ≤ V _I ≤ V _{CC}	-10	+10	μA
I _{OZ}	Output Leakage Current	GND ≤ V _O ≤ V _{CC} , Output Disabled	-20	+20	μA
I _{CC}	V _{CC} Operating Supply Current	V _{CC} = Max., I _{OUT} = 0 mA, $\overline{CS}_N \leq V_{IL}$		2400	mA
I _{SB1}	Automatic \overline{CS} Power-Down Current ^[1]	Max. V _{CC} , $\overline{CS} \geq V_{IH}$, Min. Duty Cycle = 100%		1050	mA
I _{SB2}	Automatic \overline{CS} Power-Down Current ^[1]	Max. V _{CC} , $\overline{CS} \geq V_{CC} - 0.2V$, V _{IN} ≥ V _{CC} - 0.2V, or V _{IN} ≤ 0.2V		500	mA

Capacitance^[2]

Parameter	Description	Test Conditions	Max.	Unit
C _{IN}	Input Capacitance	T _A = 25°C, f = 1 MHz, V _{CC} = 3.3V	7	pF
C _{OUT}	Output Capacitance		14	pF

Notes:

1. A pull-up resistor to V_{CC} on the \overline{CS} input is required to keep the device deselected during V_{CC} power-up, otherwise I_{SB} will exceed values given.
2. Tested on a sample basis.

AC Test Loads and Waveforms

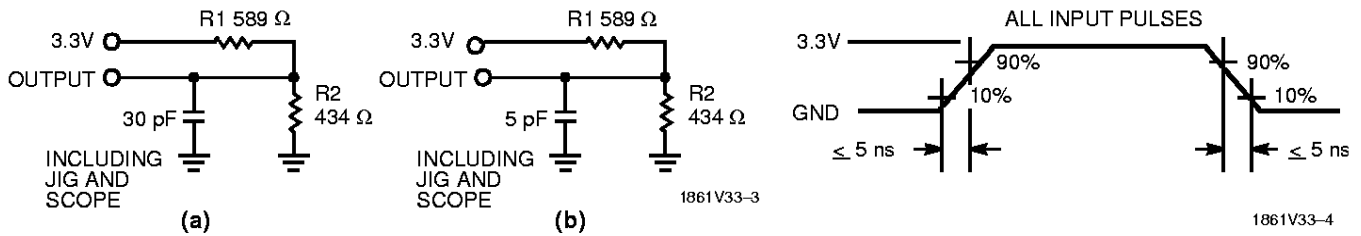

Equivalent to: THÉVENIN EQUIVALENT

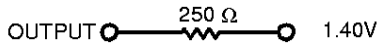

Switching Characteristics Over the Operating Range^[3]

Parameter	Description	1861V33-20		1861V33-25		Unit
		Min.	Max.	Min.	Max.	
READ CYCLE						
t _{RC}	Read Cycle Time	20		25		ns
t _{AA}	Address to Data Valid		20		25	ns
t _{OHA}	Data Hold from Address Change	3		3		ns
t _{ACS}	\overline{CS} LOW to Data Valid		20		25	ns
t _{DOE}	\overline{OE} LOW to Data Valid		12		15	ns
t _{LZOE}	\overline{OE} LOW to Low Z	0		4		ns
t _{HZOE}	\overline{OE} HIGH to High Z		10		12	ns
t _{LZCS}	\overline{CS} LOW to Low Z ^[4]	3		7		ns
t _{HZCS}	\overline{CS} HIGH to High Z ^[4, 5]		10		12	ns
t _{PD}	\overline{CS} HIGH to Power-Down		20		25	ns
WRITE CYCLE^[6]						
t _{WC}	Write Cycle Time	20		25		ns
t _{SCS}	\overline{CS} LOW to Write End	17		20		ns
t _{AW}	Address Set-Up to Write End	17		20		ns
t _{HA}	Address Hold from Write End	3		3		ns
t _{SA}	Address Set-Up to Write Start	2		2		ns
t _{PWE}	\overline{WE} Pulse Width	15		20		ns
t _{SD}	Data Set-Up to Write End	12		15		ns
t _{HD}	Data Hold from Write End	2		2		ns
t _{LZWE}	\overline{WE} HIGH to Low Z	3		3		ns
t _{HZWE}	\overline{WE} LOW to High Z ^[5]	0	12	0	12	ns

Notes:

- Test conditions assume signal transition times of 5 ns or less, timing reference levels of 1.5V, input pulse levels of 0 to 3.0V, and output loading of the specified I_{OL}/I_{OH} and 30-pF load capacitance.
- At any given temperature and voltage condition, t_{HZCS} is less than t_{LZCS} for any given device. These parameters are guaranteed and not 100% tested.
- t_{HZCS} and t_{HZWE} are specified with C_L = 5 pF as in part (b) of AC Test Loads and Waveforms. Transition is measured ±500 mV from steady-state voltage.
- The internal write time of the memory is defined by the overlap of CS LOW and WE LOW. Both signals must be LOW to initiate a write and either signal can terminate a write by going HIGH. The data input set-up and hold timing should be referenced to the rising edge of the signal that terminates the write.

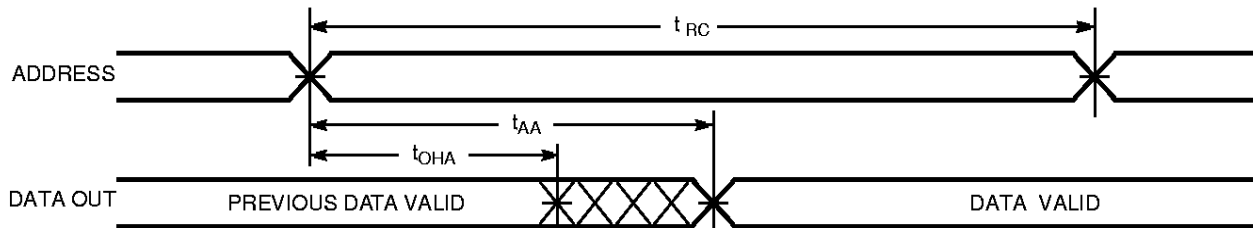
Switching Waveforms
Read Cycle No. 1 [7,8]

1861V33-5

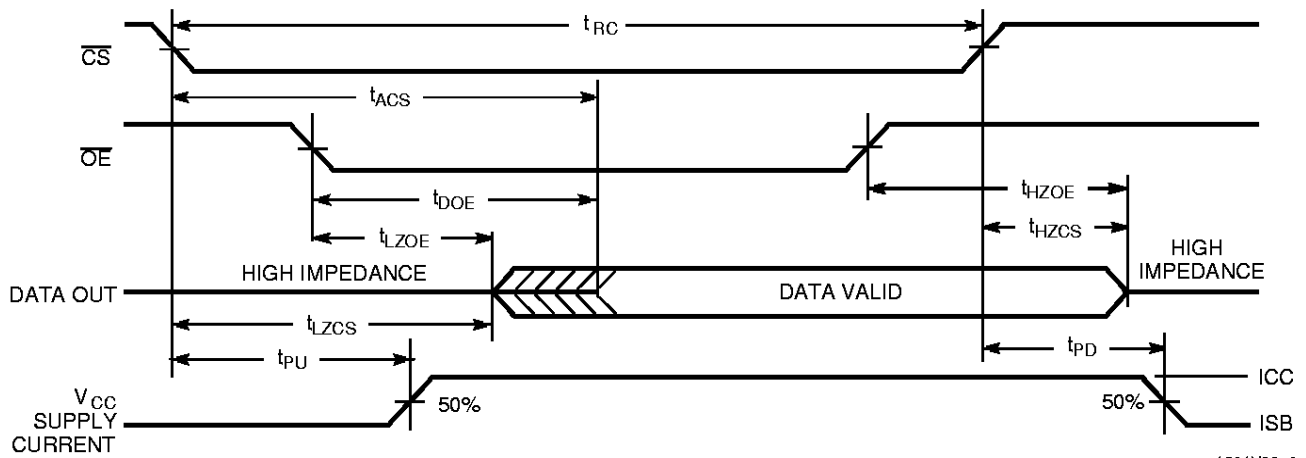
Read Cycle No. 2 [7,9]

1861V33-6

Notes:

7. \overline{WE} is HIGH for read cycle.
8. Device is continuously selected, $\overline{CS} = V_{IL}$, and $\overline{OE} = V_{IL}$.
9. Address valid prior to or coincident with \overline{CS} transition LOW.

Switching Waveforms (continued)

Write Cycle No. 1 (\overline{WE} Controlled) ^[6]

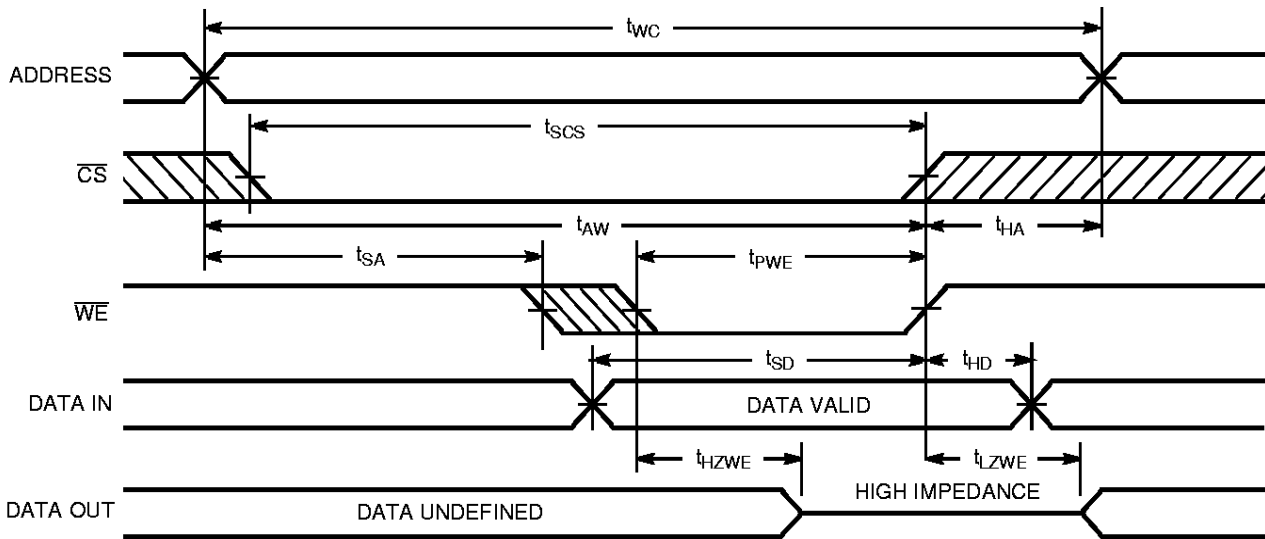

1861V33-7

Write Cycle No. 2 (\overline{CS} Controlled) ^[6,10]

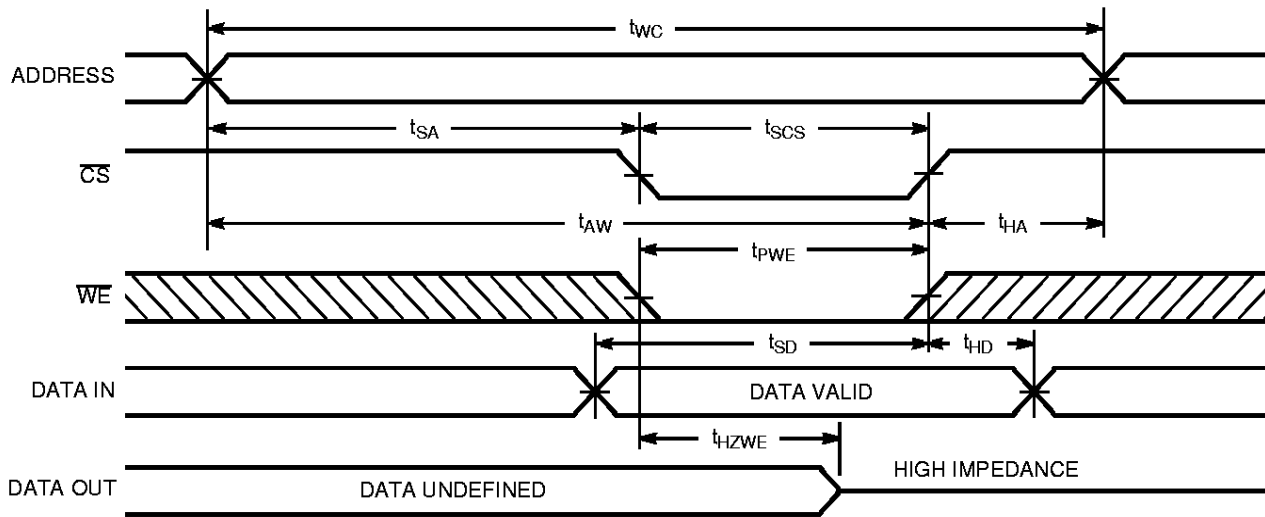

1861V33-8

Note:

10. If \overline{CS} goes HIGH simultaneously with \overline{WE} HIGH, the output remains in a high-impedance state.

Truth Table

\overline{CS}	\overline{WE}	\overline{OE}	Inputs/Output	Mode
H	X	X	High Z	Deselect/Power-Down
L	H	L	Data Out	Read
L	L	X	Data In	Write
L	H	H	High Z	Deselect

Ordering Information

Speed (ns)	Ordering Code	Package Type	Package Type	Operating Range
25	CYM1861V33PM-20C	PM48	72-Pin Plastic SIMM Module	Commercial
35	CYM1861V33PM-25C	PM48	72-Pin Plastic SIMM Module	Commercial

Document #: 38-M-00091

Package Diagram

72-Pin SIMM Module PM48

