

# Printed Circuit Dip Solder Connector

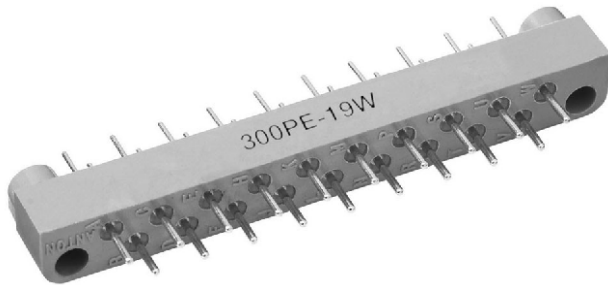

## FEATURES

- Right angle or straight through dip solder terminals
- Threaded mounting studs
- Male contacts molded in
- Mating connector has solder cup or dip solder terminals
- Female contacts float to aid in alignment and resist vibration
- Permanent mounting provides greater reliability
- Polarization provided by contact arrangement and guide pin location
- Meets applicable paragraphs of MIL-C-55302

## MATERIAL SPECIFICATIONS

**Contact Pin:** Phosphor bronze

**Contact Socket:** Phosphor bronze

**Contact Plating:** Gold plated

**Guide Pins:** Stainless steel, passivated

**Standard Body:** Glass-filled diallyl phthalate per MIL-M-14, type SDG-F green. Other body material supplied upon request

## APPLICATIONS

Where permanent mounting of male connector to printed circuit board is required with mating female connector available.

## ELECTRICAL SPECIFICATIONS

**Current Rating:** 7.5 A

**Breakdown Voltage:**

At sea level: 3600 V<sub>RMS</sub>

At 70 000 feet: 975 V<sub>RMS</sub>

## PHYSICAL SPECIFICATIONS

**Number of Contacts:** 7, 15, 19 and 25

**Contact Spacing:** 0.250", staggered rows provide a 0.125" grid

**Contact Gauge:** #20 AWG

**Minimum Creepage Path between Contacts:** 0.16"

**Minimum Air Space between Contacts:** 0.11"

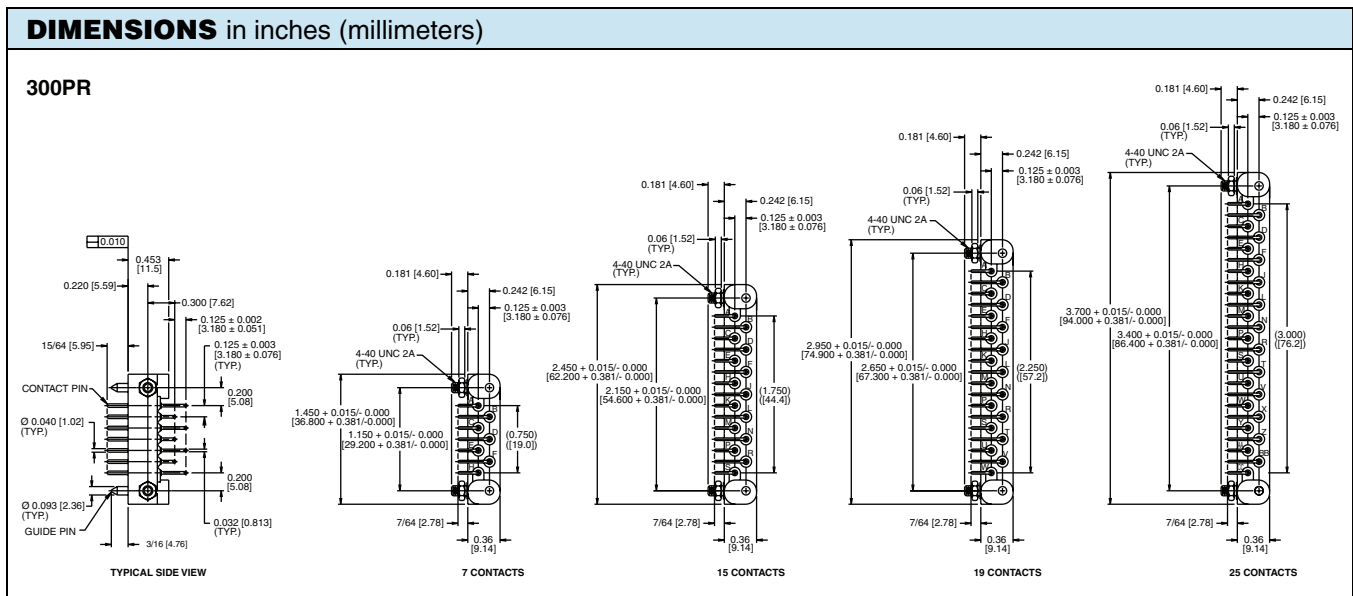

**DIMENSIONS** in inches (millimeters)

**300S**

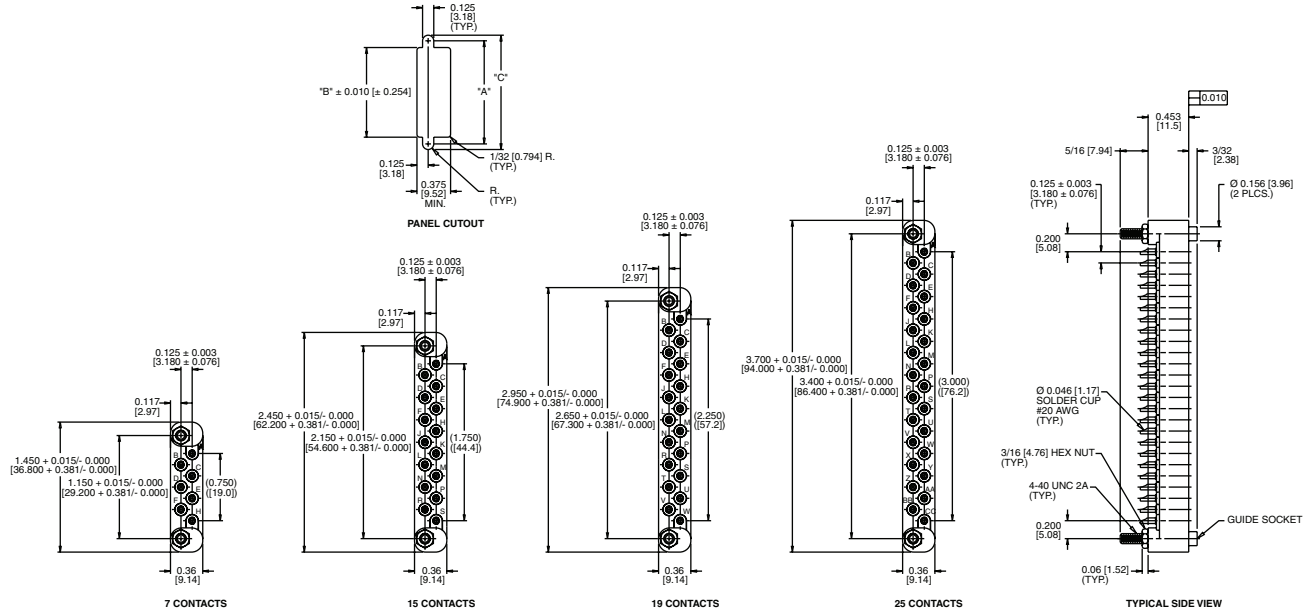

**300SE**

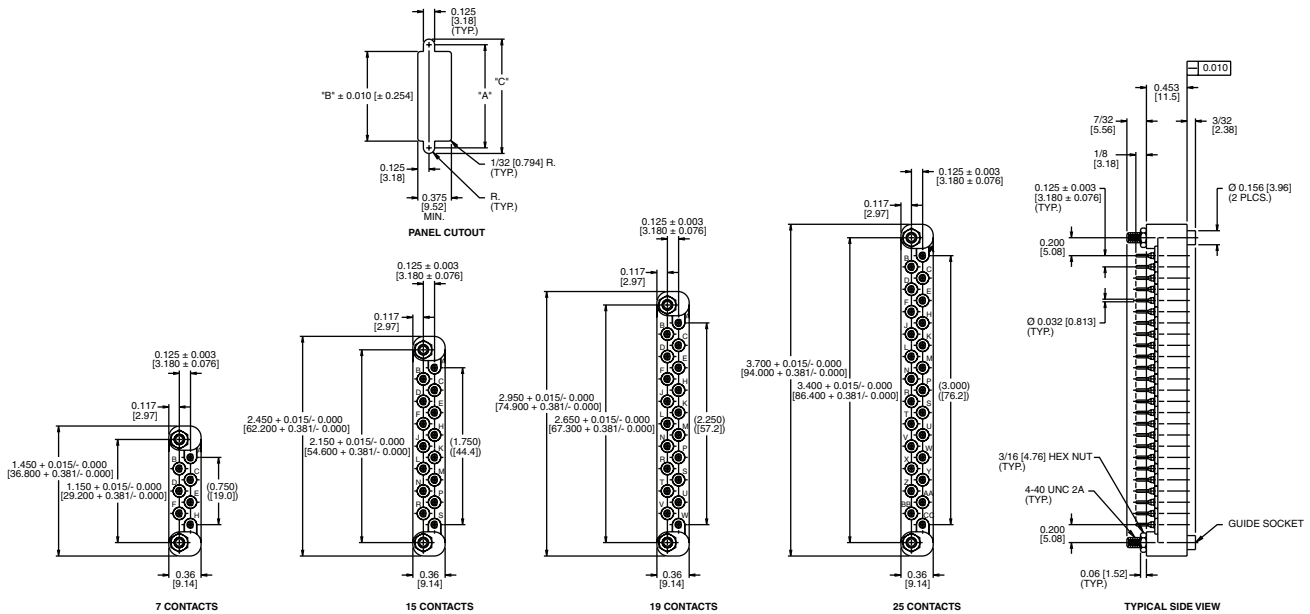

**DIMENSIONS** in inches (millimeters)

**300PE**

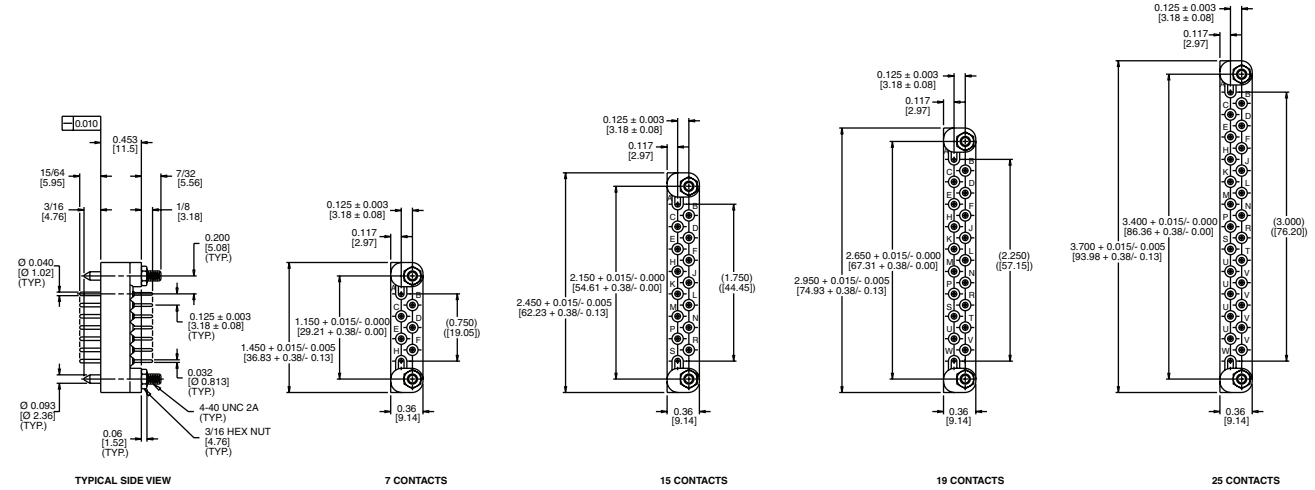

**ORDERING INFORMATION**

**300**  
MODEL

**PR**  
CONTACTS

**-7**  
NUMBER OF CONTACTS

**W**  
WITHOUT GUIDES  
(optional on S, PE, and SE models only)

S = Socket with solder cup  
 PE = Pin with dip solder terminals  
 SE = Socket with dip solder terminals  
 PR = Pin with right angle dip solder terminals



## Disclaimer

All product specifications and data are subject to change without notice.

Vishay Intertechnology, Inc., its affiliates, agents, and employees, and all persons acting on its or their behalf (collectively, "Vishay"), disclaim any and all liability for any errors, inaccuracies or incompleteness contained herein or in any other disclosure relating to any product.

Vishay disclaims any and all liability arising out of the use or application of any product described herein or of any information provided herein to the maximum extent permitted by law. The product specifications do not expand or otherwise modify Vishay's terms and conditions of purchase, including but not limited to the warranty expressed therein, which apply to these products.

No license, express or implied, by estoppel or otherwise, to any intellectual property rights is granted by this document or by any conduct of Vishay.

The products shown herein are not designed for use in medical, life-saving, or life-sustaining applications unless otherwise expressly indicated. Customers using or selling Vishay products not expressly indicated for use in such applications do so entirely at their own risk and agree to fully indemnify Vishay for any damages arising or resulting from such use or sale. Please contact authorized Vishay personnel to obtain written terms and conditions regarding products designed for such applications.

Product names and markings noted herein may be trademarks of their respective owners.