

DSP56F802

Preliminary Technical Data

DSP56F802 16-bit Digital Signal Processor

- Up to 40 MIPS operation at 80 MHz core frequency
- DSP and MCU functionality in a unified, C-efficient architecture
- MCU-friendly instruction set supports both DSP and controller functions: MAC, bit manipulation unit, 14 addressing modes
- 8K × 16-bit words Program Flash
- 1K × 16-bit words Program RAM
- 2K × 16-bit words Data Flash
- 1K × 16-bit words Data RAM
- 2K × 16-bit words Boot Flash
- Hardware DO and REP loops
- 6-channel PWM Module with fault input
- Two 12-bit ADCs (1 x 2 channel, 1 x 3 channel)
- Serial Communications Interface (SCI)
- Two General Purpose Quad Timers with 2 external outputs
- JTAG/OnCE™ port for debugging
- 4 shared GPIO
- On-chip relaxation oscillator
- 32-pin LQFP Package

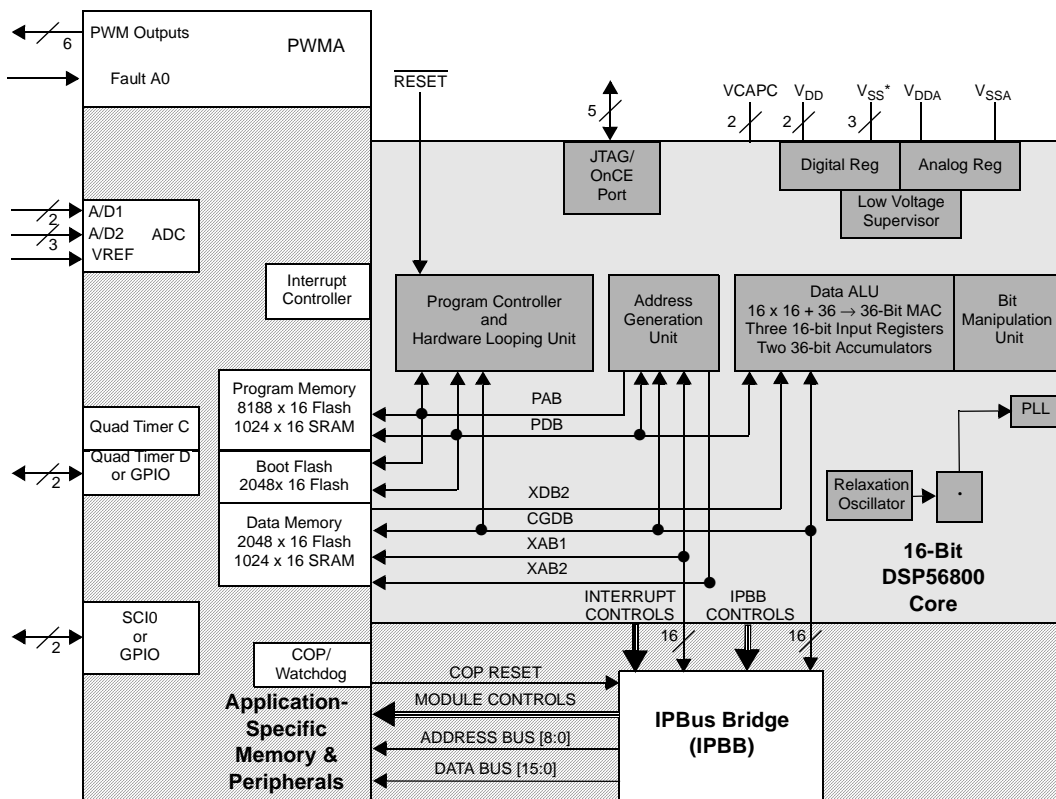

*includes TCS pin which is reserved for factory use and is tied to VSS

Figure 1. DSP56F802 Block Diagram

Part 1 Overview

1.1 DSP56F802 Features

1.1.1 Digital Signal Processing Core

- Efficient 16-bit DSP56800 family DSP engine with dual Harvard architecture
- As many as 40 Million Instructions Per Second (MIPS) at 80 MHz core frequency
- Single-cycle 16×16 -bit parallel Multiplier-Accumulator (MAC)
- Two 36-bit accumulators including extension bits
- 16-bit bidirectional barrel shifter
- Parallel instruction set with unique DSP addressing modes
- Hardware DO and REP loops
- Three internal address buses and one external address bus
- Four internal data buses and one external data bus
- Instruction set supports both DSP and controller functions
- Controller style addressing modes and instructions for compact code
- Efficient C compiler and local variable support
- Software subroutine and interrupt stack with depth limited only by memory
- JTAG/OnCE debug programming interface

1.1.2 Memory

- Harvard architecture permits as many as three simultaneous accesses to program and data memory
- On-chip memory including a low-cost, high-volume flash solution
 - $8K \times 16$ bit words of Program Flash
 - $1K \times 16$ -bit words of Program RAM
 - $2K \times 16$ -bit words of Data Flash
 - $1K \times 16$ -bit words of Data RAM
 - $2K \times 16$ -bit words of Boot Flash
- Programmable Boot Flash supports customized boot code and field upgrades of stored code through a variety of interfaces (JTAG)

1.1.3 Peripheral Circuits for DSP56F802

- Pulse Width Modulator (PWM) with six PWM outputs with deadtime insertion and fault protection; supports both center- and edge-aligned modes
- Two 12-bit, Analog-to-Digital Converters (ADCs), 1 x 2 channel and 1 x 3 channel, which support two simultaneous conversions; ADC and PWM modules can be synchronized
- Two General Purpose Quad Timers with two external pins (or two GPIO)
- Serial Communication Interface (SCI) with two pins (or two GPIO)
- Four multiplexed General Purpose I/O (GPIO) pins

- Computer-Operating Properly (COP) watchdog timer
- External interrupts via GPIO
- Trimmable on-chip relaxation oscillator
- External reset pin for hardware reset
- JTAG/On-Chip Emulation (OnCE™) for unobtrusive, processor speed-independent debugging
- Software-programmable, Phase Lock Loop-based frequency synthesizer for the DSP core clock

1.1.4 Energy Information

- Fabricated in high-density CMOS with 5V tolerant, TTL-compatible digital inputs
- Uses a single 3.3V power supply
- On-chip regulators for digital and analog circuitry to lower cost and reduce noise
- Wait and Stop modes available
- Integrated power supervisor

1.2 DSP56F802 Description

The DSP56F802 is a member of the DSP56800 core-based family of Digital Signal Processors (DSPs). It combines, on a single chip, the processing power of a DSP and the functionality of a microcontroller with a flexible set of peripherals to create an extremely cost-effective solution. Because of its low cost, configuration flexibility, and compact program code, the DSP56F802 is well-suited for many applications. The DSP56F802 includes many peripherals that are especially useful for applications such as motion control, home appliances, encoders, tachometers, limit switches, power supply and control, engine management, and industrial control for power, lighting, automation and HVAC.

The DSP56800 core is based on a Harvard-style architecture consisting of three execution units operating in parallel, allowing as many as six operations per instruction cycle. The microprocessor-style programming model and optimized instruction set allow straightforward generation of efficient, compact code for both DSP and MCU applications. The instruction set is also highly efficient for C compilers to enable rapid development of optimized control applications.

The DSP56F802 supports program execution from either internal or external memories. Two data operands can be accessed from the on-chip data RAM per instruction cycle. The DSP56F802 also provides and up to 4 General Purpose Input/Output (GPIO) lines, depending on peripheral configuration.

The DSP56F802 DSP controller includes 8K words (16-bit) of program Flash and 2K words of Data Flash (each programmable through the JTAG port) with 1K words of both program and data RAM. A total of 2K words of Boot Flash is incorporated for easy customer-inclusion of field-programmable software routines that can be used to program the main program and data flash memory areas. Both program and data flash memories can be independently bulk erased or erased in page sizes of 256 words. The Boot Flash memory can also be either bulk or page erased.

A key application-specific feature of the DSP56F802 is the inclusion of a Pulse Width Modulator (PWM) module. This module incorporates six complementary, individually programmable PWM signal outputs to enhance motor control functionality. Complementary operation permits programmable dead-time insertion, and separate top and bottom output polarity control. The up-counter value is programmable to support a continuously variable PWM frequency. Both edge and center aligned synchronous pulse width control (0% to 100% modulation) are supported. The device is capable of controlling most motor types: ACIM (AC

Induction Motors), both BDC and BLDC (Brush and Brushless DC motors), SRM and VRM (Switched and Variable Reluctance Motors), and stepper motors. The PWMs incorporate fault protection with sufficient output drive capability to directly drive standard opto-isolators. A “smoke-inhibit”, write-once protection feature for key parameters is also included. The PWM is double-buffered and includes interrupt control to permit integral reload rates to be programmable from 1 to 16. The PWM modules provide a reference output to synchronize the Analog-to-Digital Converters.

The DSP56F802 incorporates two 12-bit Analog-to-Digital Converters (ADCs) with a total of five channels. A full set of standard programmable peripherals is provided that include a Serial Communications Interface (SCI), and two Quad Timers. Any of these interfaces can be used as General-Purpose Input/Outputs (GPIO) if that function is not required. An on-chip relaxation oscillator eliminates the need for an external crystal.

1.3 “Best in Class” Development Environment

The SDK (Software Development Kit) provides fully debugged peripheral drivers, libraries and interfaces that allow programmers to create their unique C application code independent of component architecture. The CodeWarrior Integrated Development Environment is a sophisticated tool for code navigation, compiling, and debugging. A complete set of evaluation modules (EVMs) and development system cards support concurrent engineering. Together, the SDK, CodeWarrior, and EVMs create a complete, scalable tools solution for easy, fast, and efficient development.

1.4 Product Documentation

The four documents listed in [Table 1](#) are required for a complete description and proper design with the DSP56F802. Documentation is available from local Motorola distributors, Motorola semiconductor sales offices, Motorola Literature Distribution Centers, or online at www.motorola.com/semiconductors/dsp.

Table 1. DSP56F802 Chip Documentation

Topic	Description	Order Number
DSP56800 Family Manual	Detailed description of the DSP56800 family architecture, and 16-bit DSP core processor and the instruction set	DSP56800FM/D
DSP56F801/803/805/807 User's Manual	Detailed description of memory, peripherals, and interfaces of the DSP56F801, DSP56F802, DSP56F803, DSP56F805, and DSP56F807	DSP56F801-7UM/D
DSP56F802 Technical Data Sheet	Electrical and timing specifications, pin descriptions, and package descriptions (this document)	DSP56F802/D
DSP56F802 Product Brief	Summary description and block diagram of the DSP56F802 core, memory, peripherals and interfaces	DSP56F802PB/D

1.5 Data Sheet Conventions

This data sheet uses the following conventions:

$\overline{\text{OVERBAR}}$ This is used to indicate a signal that is active when pulled low. For example, the $\overline{\text{RESET}}$ pin is active when low.

“asserted” A high true (active high) signal is high or a low true (active low) signal is low.

“deasserted” A high true (active high) signal is low or a low true (active low) signal is high.

Examples:	Signal/Symbol	Logic State	Signal State	Voltage ¹
	$\overline{\text{PIN}}$	True	Asserted	$V_{\text{IL}}/V_{\text{OL}}$
	$\overline{\text{PIN}}$	False	Deasserted	$V_{\text{IH}}/V_{\text{OH}}$
	PIN	True	Asserted	$V_{\text{IH}}/V_{\text{OH}}$
	PIN	False	Deasserted	$V_{\text{IL}}/V_{\text{OL}}$

1. Values for V_{IL} , V_{OL} , V_{IH} , and V_{OH} are defined by individual product specifications.

Part 2 Signal/Connection Descriptions

2.1 Introduction

The input and output signals of the DSP56F802 are organized into functional groups, as shown in [Table 2](#) and as illustrated in [Figure 2](#). In [Table 3](#) through [Table 11](#), each table row describes the signal or signals present on a pin.

Table 2. Functional Group Pin Allocations

Functional Group	Number of Pins	Detailed Description
Power (V_{DD} or V_{DDA})	3	Table 3
Ground (V_{SS} , V_{SSA} , TCS)	4	Table 4
Supply Capacitors	2	Table 5
Program Control	1	Table 6
Pulse Width Modulator (PWM) Port and Fault Input	7	Table 7
Serial Communications Interface (SCI) Port ¹	2	Table 8
Analog-to-Digital Converter (ADC) Port (including V_{REF})	6	Table 9
Quad Timer Module Port	2	Table 10
JTAG/On-Chip Emulation (OnCE)	5	Table 11

1. Alternately, GPIO pins

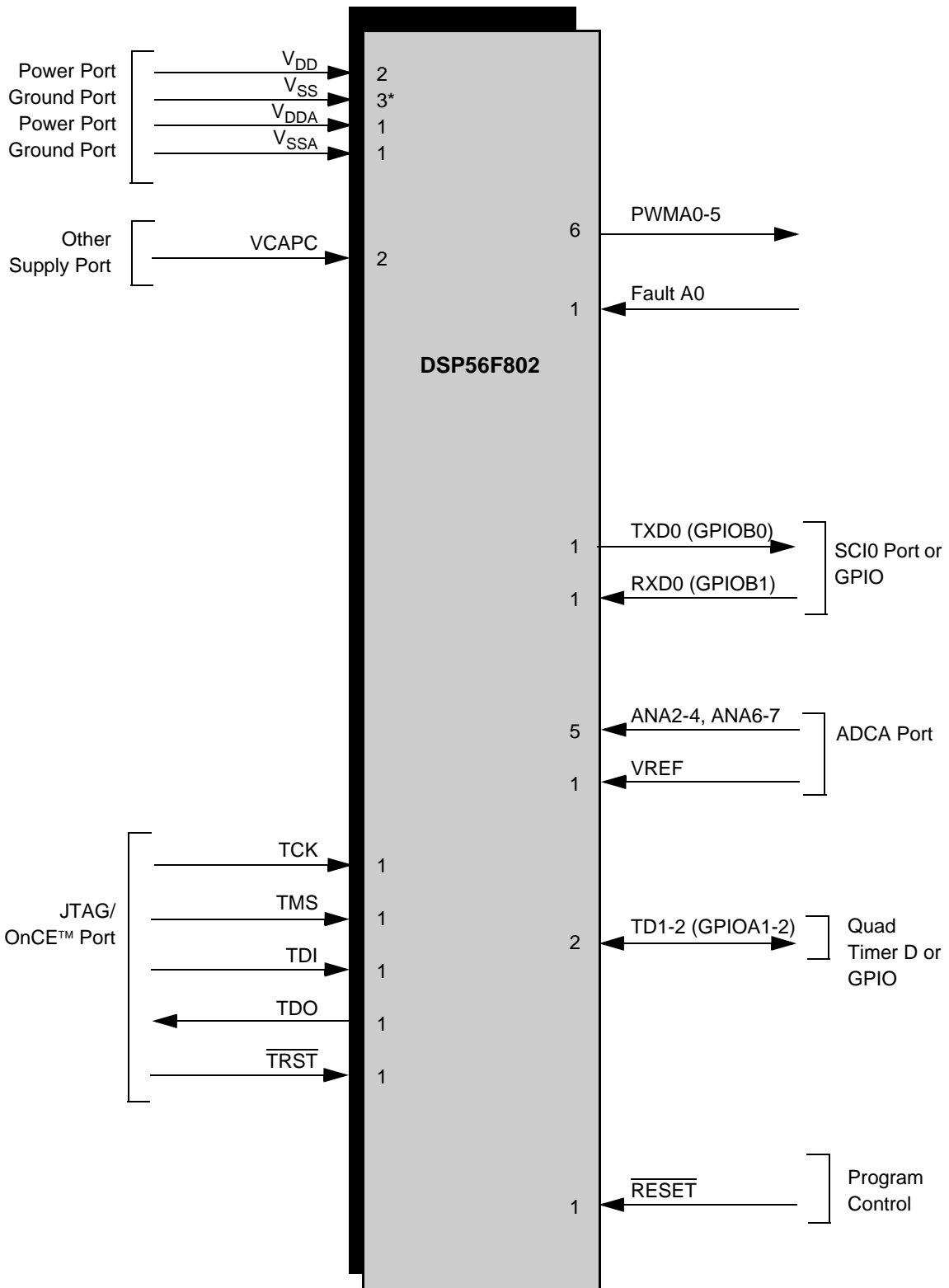

Figure 2. DSP56F802 Signals Identified by Functional Group¹

1. Alternate pin functionality is shown in parenthesis.

*includes TCS pin which is reserved for factory use and is tied to VSS

2.2 Power and Ground Signals

Table 3. Power Inputs

No. of Pins	Signal Name	Signal Description
2	V _{DD}	Power —These pins provide power to the internal structures of the chip, and should all be attached to V _{DD} .
1	V _{DDA}	Analog Power —This pin supplies an analog power source.

Table 4. Grounds

No. of Pins	Signal Name	Signal Description
2	V _{SS}	GND —These pins provide grounding for the internal structures of the chip, and should all be attached to V _{SS} .
1	V _{SSA}	Analog Ground —This pin supplies an analog ground.
1	TCS	TCS —This pin is reserved for factory use and must be tied to V _{SS} for normal use. In block diagrams, this pin is considered an additional V _{SS} .

Table 5. Supply Capacitors and VPP

No. of Pins	Signal Name	Signal Type	State During Reset	Signal Description
2	VCAPC	Supply	Supply	VCAPC - Connect each pin to a 2.2 μF bypass capacitor in order to bypass the core logic voltage regulator (required for proper chip operation). For more information, refer to Section 5.2

2.3 Interrupt and Program Control Signals

Table 6. Program Control Signals

No. of Pins	Signal Name	Signal Type	State During Reset	Signal Description
1	RESET	Input	Input	<p>Reset—This input is a direct hardware reset on the processor. When $\overline{\text{RESET}}$ is asserted low, the DSP is initialized and placed in the Reset state. A Schmitt trigger input is used for noise immunity. When the $\overline{\text{RESET}}$ pin is deasserted, the initial chip operating mode is latched from the EXTBOOT pin. The internal reset signal will be deasserted synchronous with the internal clocks, after a fixed number of internal clocks.</p> <p>To ensure complete hardware reset, $\overline{\text{RESET}}$ and $\overline{\text{TRST}}$ should be asserted together. The only exception occurs in a debugging environment when a hardware DSP reset is required and it is necessary not to reset the OnCE/JTAG module. In this case, assert $\overline{\text{RESET}}$, but do not assert $\overline{\text{TRST}}$.</p>

2.4 Pulse Width Modulator (PWM) Signals

Table 7. Pulse Width Modulator (PWMA) Signals

No. of Pins	Signal Name	Signal Type	State During Reset	Signal Description
6	PWMA0-5	Output	Tri-stated	PWMA0-5 — These are six PWMA output pins.
1	FAULTA0	Input	Input	FAULTA0 —This fault input is used for disabling selected PWMA outputs in cases where fault conditions originate off chip.

2.5 Serial Communications Interface (SCI) Signals

Table 8. Serial Communications Interface (SCI0) Signals

No. of Pins	Signal Name	Signal Type	State During Reset	Signal Description
1	TXD0	Output	Input	Transmit Data (TXD0) —transmit data output
	GPIOB0	Input/Output	Input	Port B GPIO —This pin is a General Purpose I/O (GPIO) pin that can individually be programmed as input or output pin. After reset, the default state is SCI output.
1	RXD0	Input	Input	Receive Data (RXD0) —receive data input
	GPIOB1	Input/Output	Input	Port B GPIO —This pin is a General Purpose I/O (GPIO) pin that can individually be programmed as input or output pin. After reset, the default state is SCI input.

2.6 Analog-to-Digital Converter (ADC) Signals

Table 9. Analog to Digital Converter Signals

No. of Pins	Signal Name	Signal Type	State During Reset	Signal Description
3	ANA2-4	Input	Input	ANA2-4 —Analog inputs to ADC channel 1
2	ANA6-7	Input	Input	ANA6-7 —Analog inputs to ADC channel 2
1	VREF	Input	Input	VREF —Analog reference voltage. Must be set to $V_{DDA} - 0.3V = 3.0V$ for optimal performance.

2.7 Quad Timer Module Signals

Table 10. Quad Timer Module Signals

No. of Pins	Signal Name	Signal Type	State During Reset	Signal Description
2	TD1-2	Input/Output	Input	TD1-2 —Timer D Channel 1-2
	GPIOA1-2	Input/Output	Input	Port A GPIO —These pins are General Purpose I/O (GPIO) pins that can individually be programmed as input or output pins. After reset, the default state is the quad timer input.

2.8 JTAG/OnCE

Table 11. JTAG/On-Chip Emulation (OnCE) Signals

No. of Pins	Signal Name	Signal Type	State During Reset	Signal Description
1	TCK	Input	Input, pulled low internally	Test Clock Input —This input pin provides a gated clock to synchronize the test logic and shift serial data to the JTAG/OnCE port. The pin is connected internally to a pull-down resistor.
1	TMS	Input	Input, pulled high internally	Test Mode Select Input —This input pin is used to sequence the JTAG TAP controller's state machine. It is sampled on the rising edge of TCK and has an on-chip pull-up resistor.
1	TDI	Input	Input, pulled high internally	Test Data Input —This input pin provides a serial input data stream to the JTAG/OnCE port. It is sampled on the rising edge of TCK and has an on-chip pull-up resistor.
1	TDO	Output	Tri-stated	Test Data Output —This tri-statable output pin provides a serial output data stream from the JTAG/OnCE port. It is driven in the Shift-IR and Shift-DR controller states, and changes on the falling edge of TCK.
1	TRST	Input	Input, pulled high internally	Test Reset —As an input, a low signal on this pin provides a reset signal to the JTAG TAP controller. To ensure complete hardware reset, $\overline{\text{TRST}}$ should be asserted whenever $\overline{\text{RESET}}$ is asserted. The only exception occurs in a debugging environment, since the OnCE/JTAG module is under the control of the debugger. In this case it is not necessary to assert $\overline{\text{TRST}}$ when asserting $\overline{\text{RESET}}$. Outside of a debugging environment $\overline{\text{RESET}}$ should be permanently asserted by grounding the signal, thus disabling the OnCE/JTAG module on the DSP.

Part 3 Specifications

3.1 General Characteristics

The DSP56F802 is fabricated in high-density CMOS with 5-volt tolerant TTL-compatible digital inputs. The term “5-volt tolerant” refers to the capability of an I/O pin, built on a 3.3V compatible process technology, to withstand a voltage up to 5.5V without damaging the device. Many systems have a mixture of devices designed for 3.3V and 5V power supplies. In such systems, a bus may carry both 3.3V and 5V-compatible I/O voltage levels (a standard 3.3V I/O is designed to receive a maximum voltage of $3.3V \pm 10\%$ during normal operation without causing damage). This 5V tolerant capability therefore offers the power savings of 3.3V I/O levels while being able to receive 5V levels without being damaged.

Absolute maximum ratings given in [Table 12](#) are stress ratings only, and functional operation at the maximum is not guaranteed. Stress beyond these ratings may affect device reliability or cause permanent damage to the device.

The DSP56F802 DC and AC electrical specifications are preliminary and are from design simulations. These specifications may not be fully tested or guaranteed at this early stage of the product life cycle. Finalized specifications will be published after complete characterization and device qualifications have been completed.

CAUTION

This device contains protective circuitry to guard against damage due to high static voltage or electrical fields. However, normal precautions are advised to avoid application of any voltages higher than maximum rated voltages to this high-impedance circuit. Reliability of operation is enhanced if unused inputs are tied to an appropriate voltage level.

Table 12. Absolute Maximum Ratings

Characteristic	Symbol	Min	Max	Unit
Supply voltage	V_{DD}	$V_{SS} - 0.3$	$V_{SS} + 4.0$	V
All other input voltages, excluding Analog inputs	V_{IN}	$V_{SS} - 0.3$	$V_{SS} + 5.5V$	V
Analog Inputs ANAx, V_{REF}	V_{IN}	$V_{SS} - 0.3$	$V_{DDA} + 0.3V$	V
Current drain per pin excluding V_{DD} , V_{SS} , & PWM outputs	I	—	10	mA
Current drain per pin for PWM outputs	I	—	20	mA
Junction temperature	T_J	—	150	°C
Storage temperature range	T_{STG}	-55	150	°C

Table 13. Recommended Operating Conditions

Characteristic	Symbol	Min	Max	Unit
Supply voltage	V_{DD}	3.0	3.6	V
Ambient operating temperature	T_A	-40	85	°C

Table 14. Thermal Characteristics ¹

Characteristic	32-pin LQFP		
	Symbol	Value	Unit
Junction-to-ambient (estimated)	$R_{\theta JA}$	53.2	°C/W
I/O pin power dissipation	$P_{I/O}$	User Determined	W
Power dissipation	P_D	$P_D = (I_{DD} \times V_{DD}) + P_{I/O}$	W
Maximum allowed P_D	P_{DMAX}	$(T_J - T_A) / \theta_{JA}$	°C

1. See [Section 5.1](#) for more detail.

3.2 DC Electrical Characteristics

Table 15. DC Electrical Characteristics

Operating Conditions: $V_{SS} = V_{SSA} = 0$ V, $V_{DD} = V_{DDA} = 3.0$ – 3.6 V, $T_A = -40^\circ$ to $+85^\circ$ C, $C_L \leq 50$ pF, $f_{op} = 80$ MHz

Characteristic	Symbol	Min	Typ	Max	Unit
Input high voltage	V_{IH}	2.0	—	5.5	V
Input low voltage	V_{IL}	-0.3	—	0.8	V
Input current low (pullups/pulldowns disabled)	I_{IL}	-1	—	1	μA
Input current high (pullups/pulldowns disabled)	I_{IH}	-1	—	1	μA
Typical pullup or pulldown resistance	R_{PU}, R_{PD}	—	30	—	KΩ
Input/output tri-state current low	I_{OZL}	-10	—	10	μA
Input/output tri-state current low	I_{OZH}	-10	—	10	μA
Output High Voltage (at IOH)	V_{OH}	$V_{DD} - 0.7$	—	—	V
Output Low Voltage (at IOL)	V_{OL}	—	—	0.4	V
Output High Current	I_{OH}	—	—	-4	mA
Output Low Current	I_{OL}	—	—	4	mA
Input capacitance	C_{IN}	—	8	—	pF
Output capacitance	C_{OUT}	—	12	—	pF

Table 15. DC Electrical CharacteristicsOperating Conditions: $V_{SS} = V_{SSA} = 0\text{ V}$, $V_{DD} = V_{DDA} = 3.0\text{--}3.6\text{ V}$, $T_A = -40^\circ\text{ to }+85^\circ\text{C}$, $C_L \leq 50\text{ pF}$, $f_{op} = 80\text{ MHz}$

Characteristic	Symbol	Min	Typ	Max	Unit
PWM pin output source current ¹	I_{OHP}	—	—	-10	mA
PWM pin output sink current ²	I_{OLP}	—	—	16	mA
V_{DD} supply current	I_{DDT} ³				
Run ⁴		—	103	138	mA
Wait ⁵		—	72	98	mA
Stop		—	60	84	mA
Low Voltage Interrupt ⁶ Core Voltage Interrupt	V_{EI}	2.4 —	2.7 2.2	2.9 —	V
Power on Reset ⁷	POR	—	1.7	2.0	V

- PWM pin output source current measured with 50% duty cycle.
- PWM pin output sink current measured with 50% duty cycle.
- $I_{DDT} = I_{DD} + I_{DDA}$ (Total supply current for $V_{DD} + V_{DDA}$)
- Run (operating) I_{DD} measured using 8MHz clock source. All inputs 0.2V from rail; outputs unloaded. All ports configured as inputs; measured with all modules enabled.
- Wait I_{DD} measured using internal relaxation oscillator set to 8 MHz; all inputs 0.2V from rail; no DC loads; less than 50 pF on all outputs. $C_L = 20\text{ pF}$ on EXTAL; all ports configured as inputs; measured with PLL enabled.
- Low voltage interrupt monitors the V_{DD} supply. When V_{DD} drops below V_{EI} value, an interrupt is generated. Functionality of the device is guaranteed under transient conditions when $V_{DDA} \geq V_{EI}$.
- Power on reset occurs whenever the internally regulated 2.5V digital supply drops below V_{POR} . While power is ramping up, this signal remains active for as long as the internal 2.5V supply is below 1.5V no matter how long the ramp up rate is. The internally regulated voltage is typically 100 mV less than V_{DD} during ramp up until 2.5V is reached, at which time it self regulates.

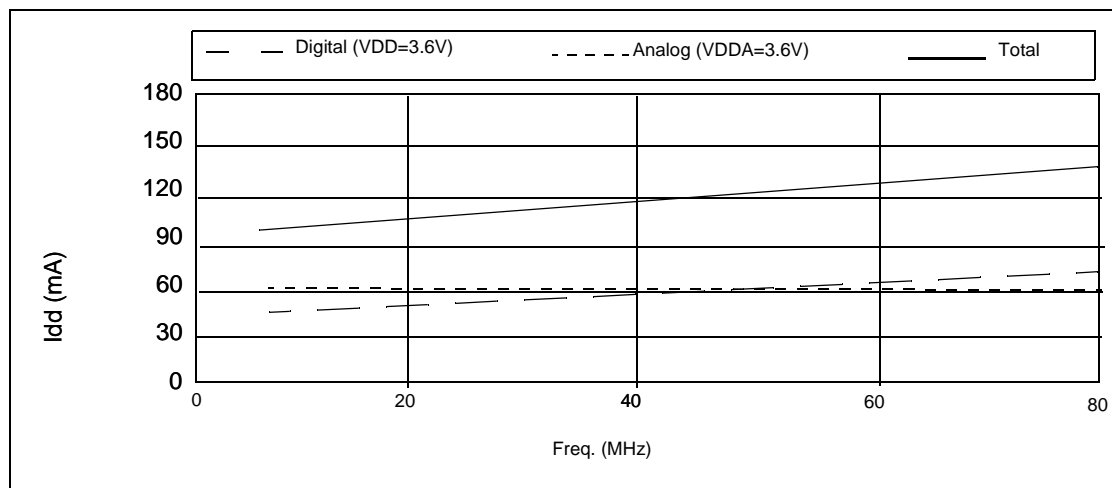
**Figure 3. Maximum Run Idd vs. Frequency (see Note 4 above)**

3.3 AC Electrical Characteristics

Timing waveforms in [Section 3.3](#) are tested with a V_{IL} maximum of 0.8 V and a V_{IH} minimum of 2.0 V for all pins except XTAL, which is tested using the input levels in [Section 3.2](#). In [Figure 4](#) the levels of V_{IH} and V_{IL} for an input signal are shown.

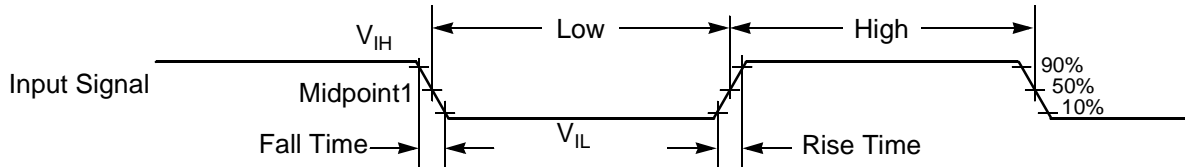

Note: The midpoint is $V_{IL} + (V_{IH} - V_{IL})/2$.

Figure 4. Input Signal Measurement References

[Figure 5](#) shows the definitions of the following signal states:

- Active state, when a bus or signal is driven, and enters a low impedance state.
- Tri-stated, when a bus or signal is placed in a high impedance state.
- Data Valid state, when a signal level has reached V_{OL} or V_{OH} .
- Data Invalid state, when a signal level is in transition between V_{OL} and V_{OH} .

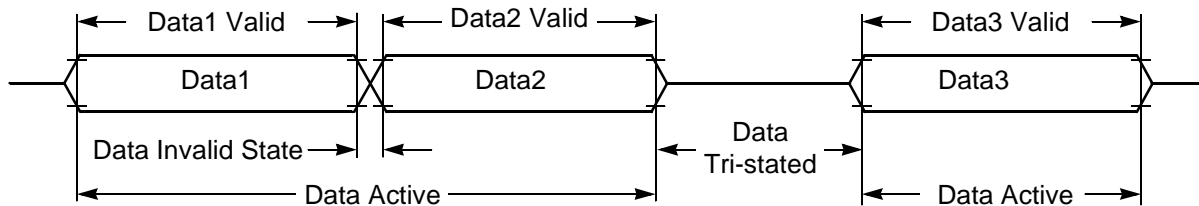

Figure 5. Signal States

3.4 Flash Memory Characteristics

Table 16. Flash Memory Truth Table

Mode	XE ¹	YE ²	SE ³	OE ⁴	PROG ⁵	ERASE ⁶	MAS1 ⁷	NVSTR ⁸
Standby	L	L	L	L	L	L	L	L
Read	H	H	H	H	L	L	L	L
Word Program	H	H	L	L	H	L	L	H
Page Erase	H	L	L	L	L	H	L	H
Mass Erase	H	L	L	L	L	H	H	H

1. X address enable, all rows are disabled when XE = 0
2. Y address enable, YMUX is disabled when YE = 0
3. Sense amplifier enable
4. Output enable, tri-state flash data out bus when OE = 0
5. Defines program cycle
6. Defines erase cycle
7. Defines mass erase cycle, erase whole block
8. Defines non-volatile store cycle

Table 17. IFREN Truth Table

Mode	IFREN = 1	IFREN = 0
Read	Read information block	Read main memory block
Word program	Program information block	Program main memory block
Page erase	Erase information block	Erase main memory block
Mass erase	Erase both blocks	Erase main memory block

Table 18. Timing Symbols

Characteristic	Symbol	See Figure(s)
PROG/ERASE to NVSTR set up time	T _{nvs}	Figure 6, Figure 7, Figure 8
NVSTR hold time	T _{nvh}	Figure 6, Figure 7
NVSTR hold time(mass erase)	T _{nvh1}	Figure 8
NVSTR to program set up time	T _{pgs}	Figure 6
Program hold time	T _{pgh}	Figure 6
Address/data set up time	T _{ads}	Figure 6
Address/data hold time	T _{adh}	Figure 6
Recovery time	T _{rcv}	Figure 6, Figure 7, Figure 8
Cumulative program HV period	T _{hv}	Figure 6
Program time	T _{prog}	Figure 6
Erase time	T _{erase}	Figure 7
Mass erase time	T _{me}	Figure 8

Table 19. Flash Timing Parameters

Operating Conditions: V_{SS} = V_{SSA} = 0 V, V_{DD} = V_{DDA} = 3.0–3.6 V, T_A = –40° to +85°C, C_L ≤ 50 pF

Characteristic	Symbol	Min	Typ	Max	Unit
Program time	T _{prog}	20	—	—	us
Erase time	T _{erase}	20	—	—	ms
Mass erase time	T _{me}	100	—	—	ms
Endurance ¹	E _{CYC}	10,000	20,000	—	cycles
Data Retention @ 5,000 Cycles ¹	D _{RET}	10	30	—	years

The following parameters should only be used in the Manual Word Programming mode.

PROG/ERASE to NVSTR set up time	T _{nvs}	—	5	—	us
NVSTR hold time	T _{nvh}	—	5	—	us
NVSTR hold time(mass erase)	T _{nvh1}	—	100	—	us
NVSTR to program set up time	T _{pgs}	—	10	—	us
Recovery time	T _{rcv}	—	1	—	us

1. One cycle is equal to an erase, program, and read.

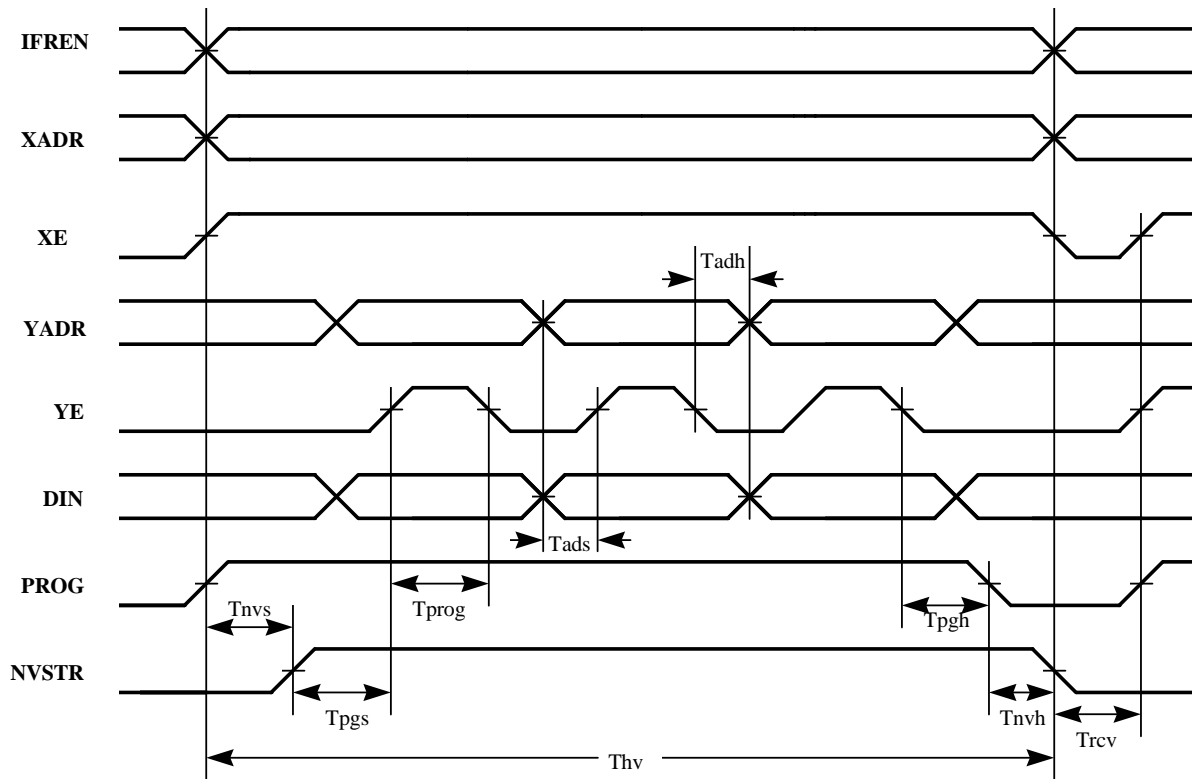

Figure 6. Flash Program Cycle

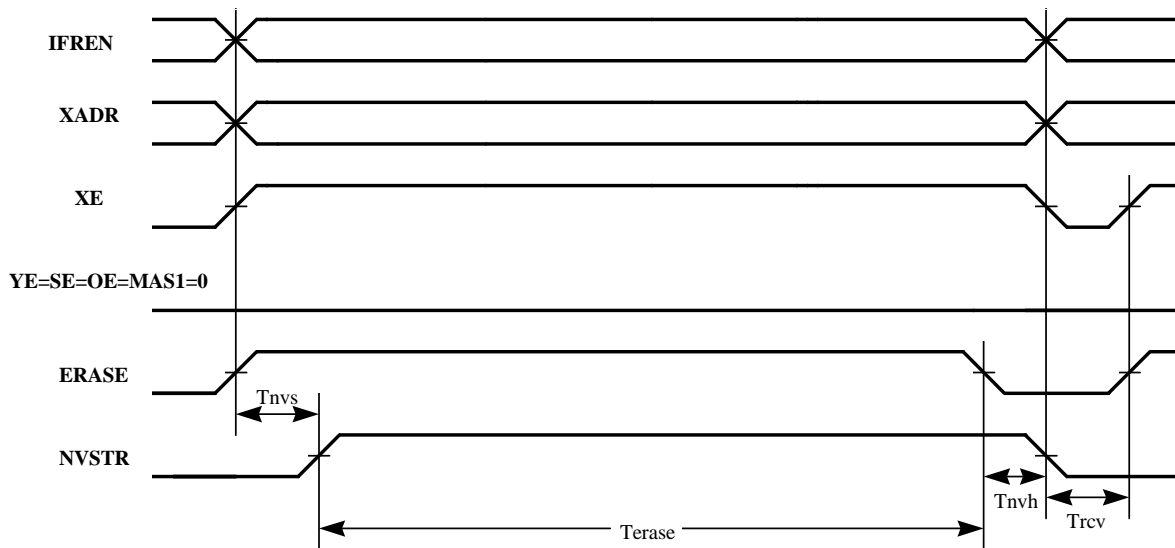

Figure 7. Flash Erase Cycle

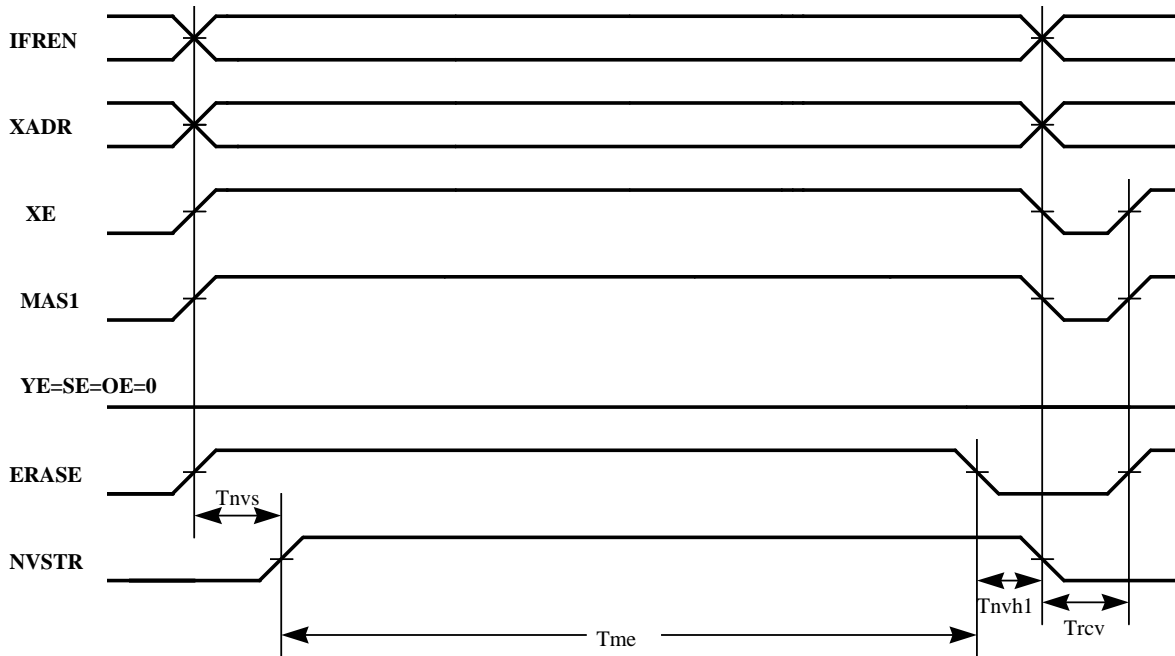

Figure 8. Flash Mass Erase Cycle

3.5 Clock Operation

The DSP56F802 device clock is derived from an on-chip relaxation oscillator. The internal PLL generates a master reference frequency that determines the speed at which chip operations occur.

The PRECS bit in the PLLCR (phase-locked loop control register) word (bit 2) must be set to 0 for internal oscillator use.

3.5.1 Use of On-Chip Relaxation Oscillator

The DSP56F802 internal relaxation oscillator provides the chip clock without the need for an external crystal or ceramic resonator. The frequency output of this internal oscillator can be corrected by adjusting the 8-bit IOSCTL (internal oscillator control) register. Each bit added or deleted changes the output frequency of the oscillator allowing incremental adjustment until the desired frequency is achieved. Figures 9 and 10 show the typical characteristics of the DSP56F802 relaxation oscillator with respect to temperature and trim value.

During factory production test, an oscillator calibration procedure is executed which determines an optimum trim value for a given device (8 MHz at 25 °C). This optimum trim value is then stored at address \$103F in the Data Flash Information Block and recalled during a trim routine in the boot sequence (executed after power-up and RESET). This trim routine automatically sets the oscillator frequency by programming the IOSCTL register with the optimum trim value.

Due to the inherent frequency tolerances required for SCI communication, changing the factory-trimmed oscillator frequency is not recommended. If modification of the Boot Flash contents are required, code must be included which retrieves the optimum trim value (from address \$103F in the Data Flash Information Block) and writes it to the IOSCTL register. Note that the IFREN bit in the Data Flash control register must be set in order to read the Data Flash Information Block.

Table 20. Relaxation Oscillator CharacteristicsOperating Conditions: $V_{SS} = V_{SSA} = 0\text{ V}$, $V_{DD} = V_{DDA} = 3.0\text{--}3.6\text{ V}$, $T_A = -40^\circ\text{ to }+85^\circ\text{C}$

Characteristic	Symbol	Min	Typ	Max	Unit
Frequency Accuracy ¹	Δf	—	± 2	± 5	%
Frequency Drift over Temp	$\Delta f/\Delta t$	—	± 0.1	—	%/ $^\circ\text{C}$
Frequency Drift over Supply	$\Delta f/\Delta V$	—	0.1	—	%/V

1. Over full temperature range.

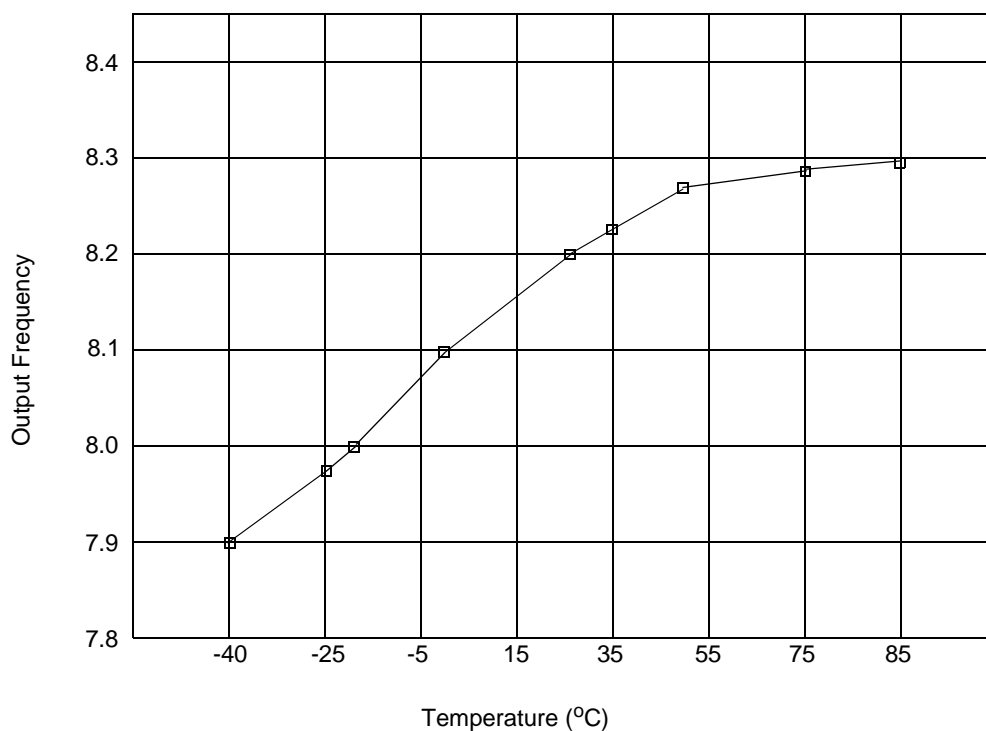
**Figure 9. Typical Relaxation Oscillator Frequency vs. Temperature (Trimmed to 8 MHz @ 25°C)**

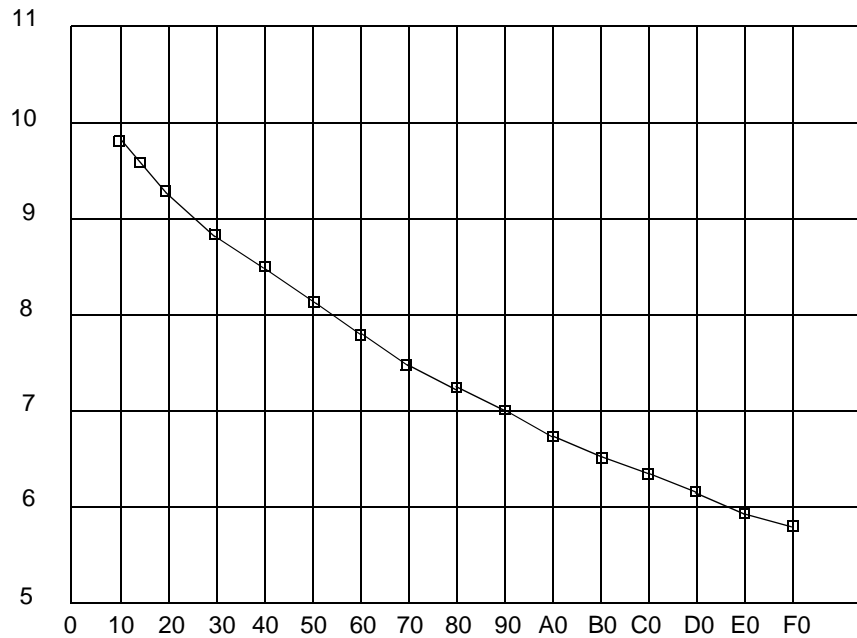

Figure 10. Typical Relaxation Oscillator Frequency vs. Trim Value @ 25°C

3.6 Reset, Stop, Wait, Mode Select, and Interrupt Timing

Table 21. Reset, Stop, Wait, Mode Select, and Interrupt Timing^{1, 5}

Operating Conditions: $V_{SS} = V_{SSA} = 0\text{ V}$, $V_{DD} = V_{DDA} = 3.0\text{--}3.6\text{ V}$, $T_A = -40^\circ\text{ to }+85^\circ\text{C}$, $C_L \leq 50\text{ pF}$

Characteristic	Symbol	Typical Min	Typical Max	Unit
$\overline{\text{RESET}}$ Assertion to Address, Data and Control Signals High Impedance	t_{RAZ}	—	21	ns
Minimum $\overline{\text{RESET}}$ Assertion Duration ² OMR Bit 6 = 0 OMR Bit 6 = 1	t_{RA}	275,000T 128T	— —	ns ns
$\overline{\text{RESET}}$ De-assertion to First External Address Output	t_{RDA}	33T	34T	ns
Edge-sensitive Interrupt Request Width	t_{IRW}	1.5T	—	ns

- In the formulas, T = clock cycle. For an operating frequency of 80 MHz, T = 12.5 ns.
- Circuit stabilization delay is required during reset when using an external clock or crystal oscillator in two cases:
 - After power-on reset
 - When recovering from Stop state

Figure 11. External Level-Sensitive Interrupt Timing

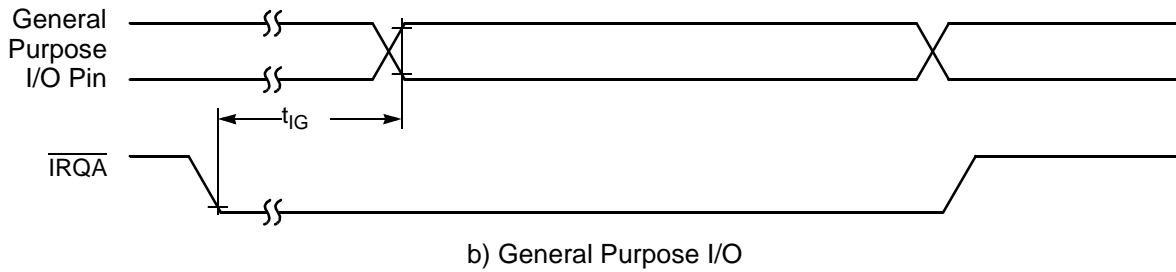

3.7 Quad Timer Timing

Table 22. Timer Timing^{1, 2}

Operating Conditions: $V_{SS} = V_{SSA} = 0\text{ V}$, $V_{DD} = V_{DDA} = 3.0\text{--}3.6\text{ V}$, $T_A = -40^\circ\text{ to }+85^\circ\text{C}$, $C_L \leq 50\text{ pF}$, $f_{OP} = 80\text{ MHz}$

Characteristic	Symbol	Typical Min	Typical Max	Unit
Timer input period	P_{IN}	$4T+6$	—	ns
Timer input high/low period	P_{INHL}	$2T+3$	—	ns
Timer output period	P_{OUT}	$2T$	—	ns
Timer output high/low period	P_{OUTHL}	$1T$	—	ns

1. In the formulas listed, T = clock cycle. For 80 MHz operation, $T = 12.5\text{ ns}$.
2. Parameters listed are guaranteed by design.

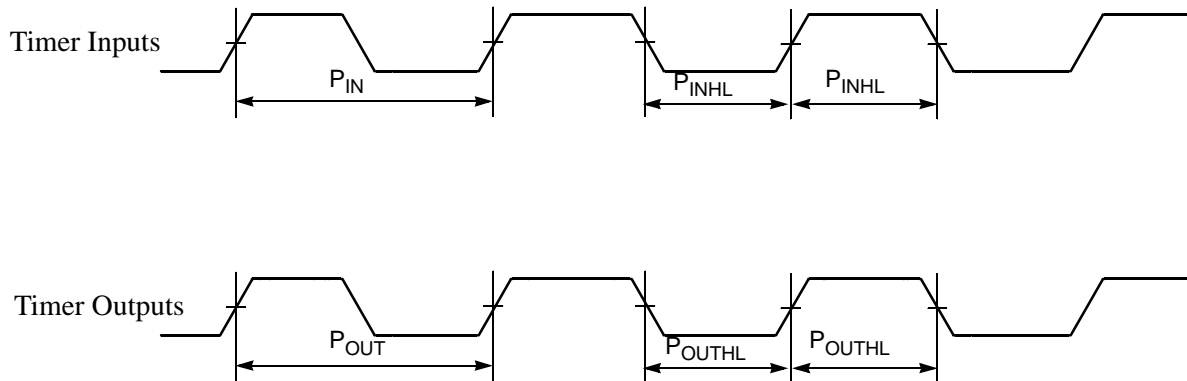

Figure 12. Timer Timing

3.8 Serial Communication Interface (SCI) Timing

Table 23. SCI Timing

Operating Conditions: $V_{SS} = V_{SSA} = 0\text{ V}$, $V_{DD} = V_{DDA} = 3.0\text{--}3.6\text{ V}$, $T_A = -40^\circ\text{ to }+85^\circ\text{C}$, $C_L \leq 50\text{ pF}$, $f_{OP} = 80\text{ MHz}$

Characteristic	Symbol	Min	Max	Unit
Baud Rate ¹	BR	—	$(f_{MAX} * 2.5) / (80)$	Mbps
RXD ² Pulse Width	RXD _{PW}	0.965/BR	1.04/BR	ns
TXD ³ Pulse Width	TXD _{PW}	0.965/BR	1.04/BR	ns

1. f_{MAX} is the frequency of operation of the system clock in MHz.
2. The RXD pin in SCI0 is named RXD0 and the RXD pin in SCI1 is named RXD1.
3. The TXD pin in SCI0 is named TXD0 and the TXD pin in SCI1 is named TXD1.
4. Parameters listed are guaranteed by design.

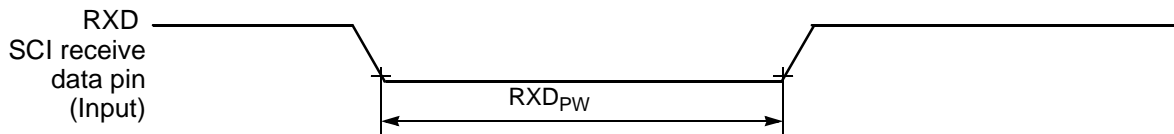

Figure 13. RXD Pulse Width

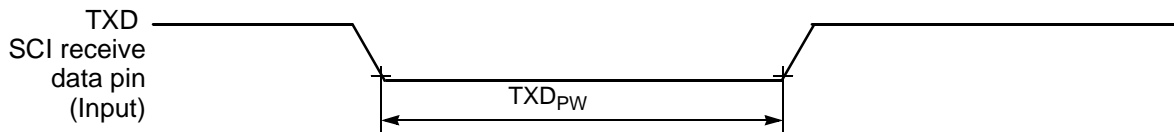

Figure 14. TXD Pulse Width

3.9 Analog-to-Digital Converter (ADC) Characteristics

Table 24. ADC Characteristics

Operating Conditions: $V_{SS} = V_{SSA} = 0\text{ V}$, $V_{DD} = V_{DDA} = 3.0\text{--}3.6\text{ V}$, $V_{REF} = V_{DD} - 0.3\text{V}$, ADCDIV = 4, 9, or 14, ADC clock = 4MHz, 3.0–3.6 V, $T_A = -40^\circ\text{ to }+85^\circ\text{C}$, $C_L \leq 50\text{ pF}$, $f_{OP} = 80\text{ MHz}$

Characteristic	Symbol	Min	Typ	Max	Unit
Input voltages	V_{ADIN}	0	—	V_{DDA}^1	V
Resolution	R_{ES}	12	—	12	Bits
Integral Non-Linearity ²	INL	—	+/- 4	+/- 5	LSB ³
Differential Non-Linearity	DNL	—	+/- 0.9	+/- 1	LSB ³
Monotonicity	GUARANTEED				
ADC internal clock	f_{ADIC}	0.5	—	5	MHz
Conversion range	R_{AD}	V_{SSA}	—	V_{DDA}	V

Table 24. ADC Characteristics (Continued)

Operating Conditions: $V_{SS} = V_{SSA} = 0\text{ V}$, $V_{DD} = V_{DDA} = 3.0\text{--}3.6\text{ V}$, $V_{REF} = V_{DD} - 0.3\text{ V}$, $ADCDIV = 4, 9, \text{ or } 14$,
 ADC clock = 4MHz, 3.0–3.6 V, $T_A = -40^\circ\text{ to } +85^\circ\text{C}$, $C_L \leq 50\text{ pF}$, $f_{OP} = 80\text{ MHz}$

Characteristic	Symbol	Min	Typ	Max	Unit
Power-up time	t_{ADPU}	—	2.5	—	msec
Conversion time	t_{ADC}	—	6	—	$t_{AIC}\text{ cycles}^4$
Sample time	t_{ADS}	—	1	—	$t_{AIC}\text{ cycles}^4$
Input capacitance	C_{ADI}	—	5	—	pF^4
Gain Error (transfer gain)	E_{GAIN}	1.00	1.10	1.15	—
Offset Voltage	V_{OFFSET}	+10	+230	+325	mV
Total Harmonic Distortion	THD	55	60	—	dB
Signal-to-Noise plus Distortion	SINAD	54	56	—	—
Effective Number of Bits	ENOB	8.5	9.5	—	bit
Spurious Free Dynamic Range	SFDR	60	65	—	dB
Spurious Free Dynamic Range	SFDR	65	70	—	dB
ADC Quiescent Current (both ADCs)	I_{ADC}	—	39.3	—	mA
V_{REF} Quiescent Current (both ADCs)	I_{VREF}	—	11.85	14.5	mA

1. V_{DDA} should be tied to the same potential as V_{DD} via separate traces. V_{REF} must be equal to or less than V_{DD} and must be greater than or equal to 2.7V.
2. Measured in 10-90% range.
3. LSB = Least Significant Bit.
4. $t_{AIC} = 1/f_{ADIC}$

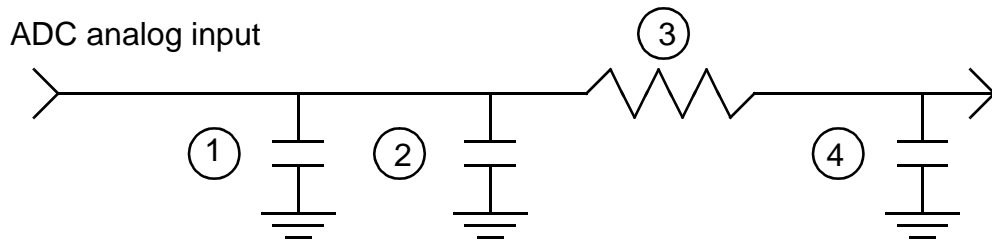

Figure 15. Equivalent Analog Input Circuit

1. Parasitic capacitance due to package, pin to pin, and pin to package base coupling. 1.8pf
2. Parasitic capacitance due to the chip bond pad, ESD protection devices and signal routing. 2.04pf
3. Equivalent resistance for the ESD isolation resistor and the channel select mux. 500 ohms

Sampling capacitor at the sample and hold circuit. Capacitor 4 is normally disconnected from the input and is only connected to it at sampling time. 1pf

3.10 JTAG Timing

Table 25. JTAG Timing^{1, 3}

Operating Conditions: $V_{SS} = V_{SSA} = 0$ V, $V_{DD} = V_{DDA} = 3.0\text{--}3.6$ V, $T_A = -40^\circ$ to $+85^\circ$ C, $C_L \leq 50$ pF, $f_{OP} = 80$ MHz

Characteristic	Symbol	Min	Max	Unit
TCK frequency of operation ²	f_{OP}	DC	10	MHz
TCK cycle time	t_{CY}	100	—	ns
TCK clock pulse width	t_{PW}	50	—	ns
TMS, TDI data setup time	t_{DS}	0.4	—	ns
TMS, TDI data hold time	t_{DH}	1.2	—	ns
TCK low to TDO data valid	t_{DV}	—	26.6	ns
TCK low to TDO tri-state	t_{TS}	—	23.5	ns
\overline{TRST} assertion time	t_{TRST}	50	—	ns

1. Timing is both wait state and frequency dependent. For the values listed, T = clock cycle. For 80 MHz operation, T = 12.5 ns.
2. TCK frequency of operation must be less than 1/8 the processor rate.
3. Parameters listed are guaranteed by design.

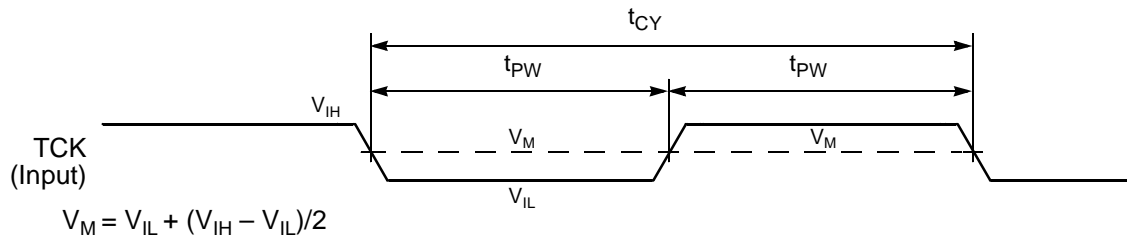

Figure 16. Test Clock Input Timing Diagram

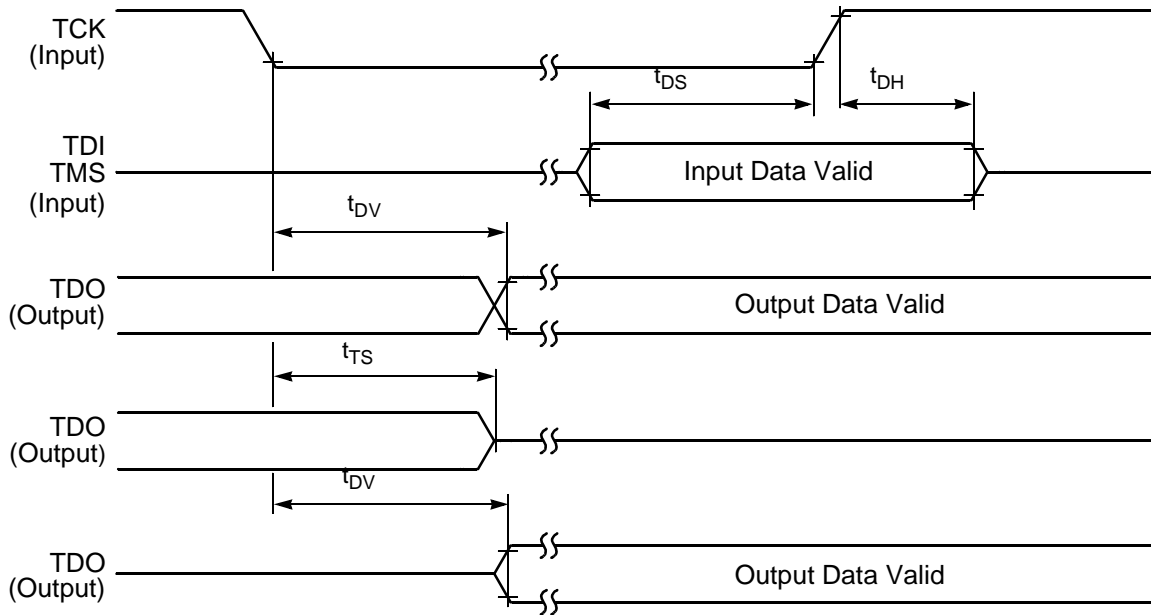

Figure 17. Test Access Port Timing Diagram



Figure 18. $\overline{\text{TRST}}$ Timing Diagram

Part 4 Packaging

4.1 Package and Pin-Out Information DSP56F802

This section contains package and pin-out information for the 32-pin LQFP configuration of the DSP56F802.

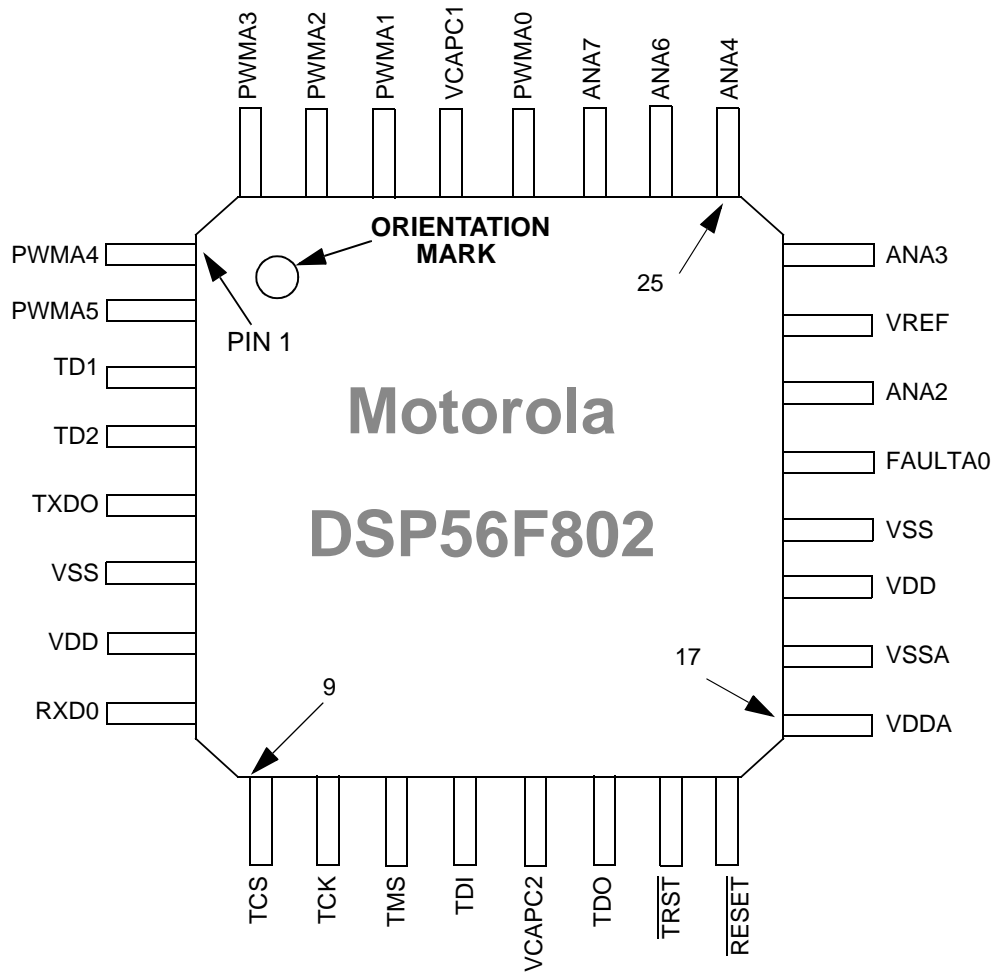

Figure 19. Top View, DSP56F802 32-pin LQFP Package

Table 26. DSP56F802 Pin Identification by Pin Number

Pin No.	Signal Name	Pin No.	Signal Name	Pin No.	Signal Name	Pin No.	Signal Name
1	PWMA4	9	TCS	17	V _{DDA}	25	ANA4
2	PWMA5	10	TCK	18	V _{SSA}	26	ANA6
3	TD1	11	TMS	19	V _{DD}	27	ANA7
4	TD2	12	TDI	20	V _{SS}	28	PWMA0
5	TXD0	13	VCAPC2	21	FAULTA0	29	VCAPC1
6	V _{SS}	14	TDO	22	ANA2	30	PWMA1
7	V _{DD}	15	$\overline{\text{TRST}}$	23	VREF	31	PWMA2
8	RXD0	16	$\overline{\text{RESET}}$	24	ANA3	32	PWMA3

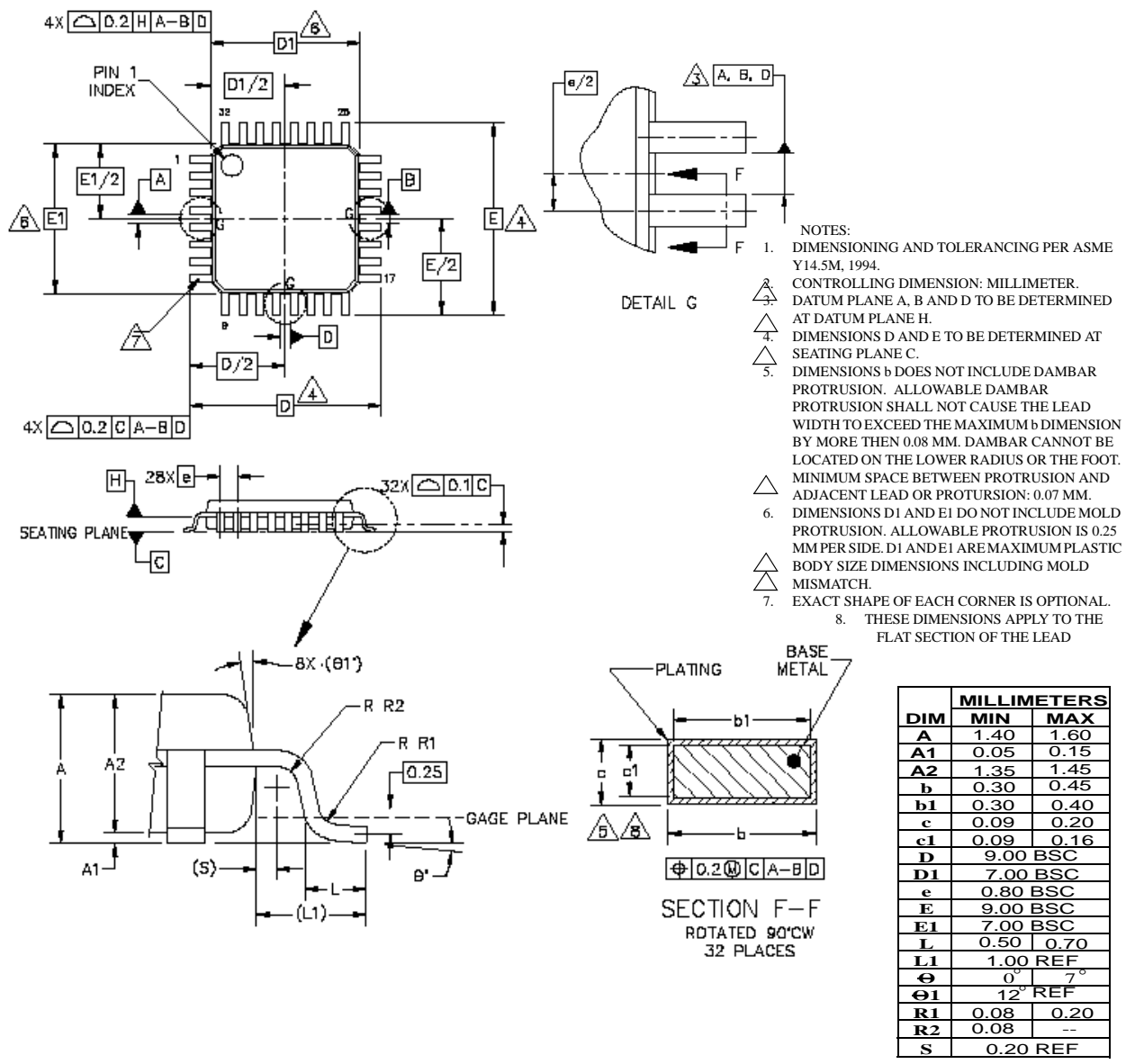

Figure 20. 32-pin LQFP Mechanical Information (Case 873A)

Part 5 Design Considerations

5.1 Thermal Design Considerations

An estimation of the chip junction temperature, T_J , in °C can be obtained from the equation:

$$\text{Equation 1: } T_J = T_A + (P_D \times R_{\theta JA})$$

Where:

T_A = ambient temperature °C

$R_{\theta JA}$ = package junction-to-ambient thermal resistance °C/W

P_D = power dissipation in package

Historically, thermal resistance has been expressed as the sum of a junction-to-case thermal resistance and a case-to-ambient thermal resistance:

$$\text{Equation 2: } R_{\theta JA} = R_{\theta JC} + R_{\theta CA}$$

Where:

$R_{\theta JA}$ = package junction-to-ambient thermal resistance °C/W

$R_{\theta JC}$ = package junction-to-case thermal resistance °C/W

$R_{\theta CA}$ = package case-to-ambient thermal resistance °C/W

$R_{\theta JC}$ is device-related and cannot be influenced by the user. The user controls the thermal environment to change the case-to-ambient thermal resistance, $R_{\theta CA}$. For example, the user can change the air flow around the device, add a heat sink, change the mounting arrangement on the Printed Circuit Board (PCB), or otherwise change the thermal dissipation capability of the area surrounding the device on the PCB. This model is most useful for ceramic packages with heat sinks; some 90% of the heat flow is dissipated through the case to the heat sink and out to the ambient environment. For ceramic packages, in situations where the heat flow is split between a path to the case and an alternate path through the PCB, analysis of the device thermal performance may need the additional modeling capability of a system level thermal simulation tool.

The thermal performance of plastic packages is more dependent on the temperature of the PCB to which the package is mounted. Again, if the estimations obtained from $R_{\theta JA}$ do not satisfactorily answer whether the thermal performance is adequate, a system level model may be appropriate.

Definitions:

A complicating factor is the existence of three common definitions for determining the junction-to-case thermal resistance in plastic packages:

- Measure the thermal resistance from the junction to the outside surface of the package (case) closest to the chip mounting area when that surface has a proper heat sink. This is done to minimize temperature variation across the surface.
- Measure the thermal resistance from the junction to where the leads are attached to the case. This definition is approximately equal to a junction to board thermal resistance.
- Use the value obtained by the equation $(T_J - T_T)/P_D$ where T_T is the temperature of the package case determined by a thermocouple.

The junction-to-case thermal resistances quoted in this data sheet are determined using the first definition on page 45. From a practical standpoint, that value is also suitable for determining the junction temperature from a case thermocouple reading in forced convection environments. In natural convection, using the junction-to-case thermal resistance to estimate junction temperature from a thermocouple reading on the case of the package will estimate a junction temperature slightly hotter than actual. Hence, the new thermal metric, Thermal Characterization Parameter, or Ψ_{JT} , has been defined to be $(T_J - T_T)/P_D$. This value gives a better estimate of the junction temperature in natural convection when using the surface temperature of the package. Remember that surface temperature readings of packages are subject to significant errors caused by inadequate attachment of the sensor to the surface and to errors caused by heat loss to the sensor. The recommended technique is to attach a 40-gauge thermocouple wire and bead to the top center of the package with thermally conductive epoxy.

5.2 Electrical Design Considerations

CAUTION

This device contains protective circuitry to guard against damage due to high static voltage or electrical fields. However, normal precautions are advised to avoid application of any voltages higher than maximum rated voltages to this high-impedance circuit. Reliability of operation is enhanced if unused inputs are tied to an appropriate voltage level.

Use the following list of considerations to assure correct DSP operation:

- Provide a low-impedance path from the board power supply to each V_{DD} pin on the DSP, and from the board ground to each V_{SS} (GND) pin.
- The minimum bypass requirement is to place six 0.01–0.1 μF capacitors positioned as close as possible to the package supply pins. The recommended bypass configuration is to place one bypass capacitor on each of the ten V_{DD}/V_{SS} pairs, including V_{DDA}/V_{SSA} . The VCAP capacitors must be 150 milliohm or less ESR capacitors.
- Ensure that capacitor leads and associated printed circuit traces that connect to the chip V_{DD} and V_{SS} (GND) pins are less than 0.5 inch per capacitor lead.
- Use at least a four-layer Printed Circuit Board (PCB) with two inner layers for V_{DD} and V_{SS} .
- Bypass the V_{DD} and V_{SS} layers of the PCB with approximately 100 μF , preferably with a high-grade capacitor such as a tantalum capacitor.
- Because the DSP output signals have fast rise and fall times, PCB trace lengths should be minimal.
- Consider all device loads as well as parasitic capacitance due to PCB traces when calculating capacitance. This is especially critical in systems with higher capacitive loads that could create higher transient currents in the V_{DD} and GND circuits.
- Take special care to minimize noise levels on the V_{REF} , V_{DDA} and V_{SSA} pins.

- Designs that utilize the $\overline{\text{TRST}}$ pin for JTAG port or OnCE module functionality (such as development or debugging systems) should allow a means to assert $\overline{\text{TRST}}$ whenever $\overline{\text{RESET}}$ is asserted, as well as a means to assert $\overline{\text{TRST}}$ independently of $\overline{\text{RESET}}$. Designs that do not require debugging functionality, such as consumer products, should tie these pins together. $\overline{\text{TRST}}$ must be asserted at power up for proper operation.
- Because the Flash memory is programmed through the JTAG/OnCE port, designers should provide an interface to this port to allow in-circuit Flash programming.

Part 6 Ordering Information

Table 27 lists the pertinent information needed to place an order. Consult a Motorola Semiconductor sales office or authorized distributor to determine availability and to order parts.

Table 27. DSP56F802 Ordering Information

Part	Supply Voltage	Package Type	Pin Count	Frequency (MHz)	Order Number
DSP56F802	3.0–3.6 V	Low Profile Plastic Quad Flat Pack (LQFP)	32	80	DSP56F802TA80

Motorola reserves the right to make changes without further notice to any products herein. Motorola makes no warranty, representation or guarantee regarding the suitability of its products for any particular purpose, nor does Motorola assume any liability arising out of the application or use of any product or circuit, and specifically disclaims any and all liability, including without limitation consequential or incidental damages. "Typical" parameters which may be provided in Motorola data sheets and/or specifications can and do vary in different applications and actual performance may vary over time. All operating parameters, including "Typicals" must be validated for each customer application by customer's technical experts. Motorola does not convey any license under its patent rights nor the rights of others. Motorola products are not designed, intended, or authorized for use as components in systems intended for surgical implant into the body, or other applications intended to support or sustain life, or for any other application in which the failure of the Motorola product could create a situation where personal injury or death may occur. Should Buyer purchase or use Motorola products for any such unintended or unauthorized application, Buyer shall indemnify and hold Motorola and its officers, employees, subsidiaries, affiliates, and distributors harmless against all claims, costs, damages, and expenses, and reasonable attorney fees arising out of, directly or indirectly, any claim of personal injury or death associated with such unintended or unauthorized use, even if such claim alleges that Motorola was negligent regarding the design or manufacture of the part. Motorola and the Stylized M Logo are registered trademarks of Motorola, Inc. Motorola, Inc. is an Equal Opportunity/Affirmative Action Employer.

MOTOROLA and the Stylized M Logo are registered in the US Patent & Trademark Office. All other product or service names are the property of their respective owners. © Motorola, Inc. 2002.

How to reach us:

USA/EUROPE/Locations Not Listed: Motorola Literature Distribution; P.O. Box 5405, Denver, Colorado 80217. 1-303-675-2140 or 1-800-441-2447

JAPAN: Motorola Japan Ltd.; SPS, Technical Information Center, 3-20-1, Minami-Azabu, Minato-ku, Tokyo 106-8573 Japan. 81-3-3440-3569

ASIA/PACIFIC: Motorola Semiconductors H.K. Ltd.; Silicon Harbour Centre, 2 Dai King Street, Tai Po Industrial Estate, Tai Po, N.T., Hong Kong. 852-26668334

Technical Information Center: 1-800-521-6274

HOME PAGE: <http://www.motorola.com/semiconductors/>



MOTOROLA

DSP56F802/D