

Series 75 Tapered Pipe Thread Adapters

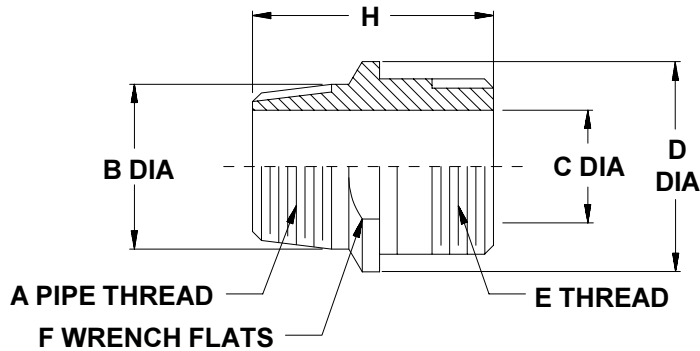

710-114/115/405

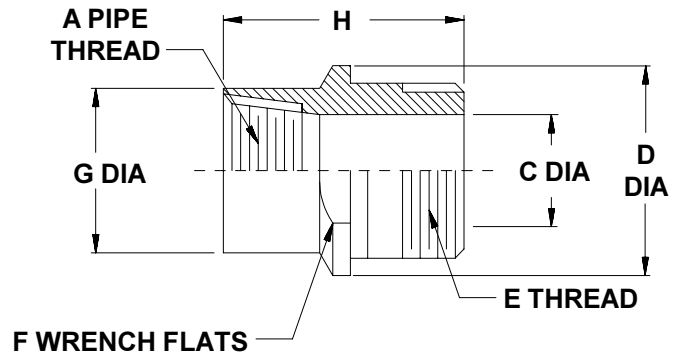

710-116/117/406

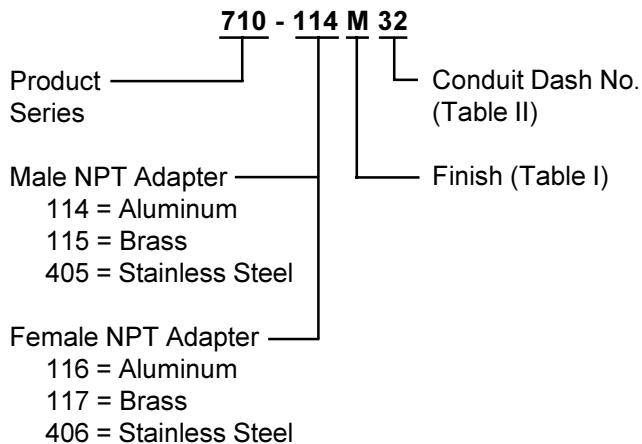

TABLE I

SYMBOL	FINISH
B	Olive Drab over Cadmium Plate
J	Gold Iridite over Cadmium Plate over Nickel
M	Electroless Nickel
N	Olive Drab over Cadmium Plate over Nickel
NC	Zinc-Cobalt, Olive Drab
NF	Olive Drab over Cadmium Plate over Electroless Nickel (500 Hour Salt Spray)
T	Bright Dip Cadmium Plate over Nickel
Z1	Passivate

TABLE II

CONDUIT DASH NO.	A PIPE THREAD	B DIA	C DIA	D DIA MAX	E THREAD CLASS 2A	F DIM	G DIA MAX	H MAX
08	1/4	.540 (13.7)	.250 (6.4)	.72 (18.3)	1/2 - 20 UNF	.625 (15.9)	.625 (15.9)	1.31 (33.3)
12	3/8	.675 (17.1)	.375 (9.5)	1.01 (25.7)	5/8 - 24 UNEF	.875 (22.2)	.875 (22.2)	1.31 (33.3)
16	1/2	.840 (21.3)	.500 (12.7)	1.15 (29.2)	3/4 - 20 UNEF	1.000 (25.4)	1.000 (25.4)	1.25 (31.8)
24	3/4	1.050 (26.7)	.750 (19.1)	1.44 (36.6)	1 - 20 UNEF	1.250 (31.8)	1.250 (31.8)	1.52 (38.6)
32	1	1.315 (33.4)	1.000 (25.4)	1.73 (43.9)	1 5/16 - 18 UNEF	1.500 (38.1)	1.500 (38.1)	1.83 (46.5)
40	1 1/4	1.660 (42.2)	1.250 (31.8)	2.02 (51.3)	1 1/2 - 18 UNEF	1.750 (44.5)	1.750 (44.5)	1.85 (47.0)
48	1 1/2	1.900 (48.3)	1.500 (38.1)	2.60 (66.0)	1 3/4 - 18 UNS	2.250 (57.2)	2.125 (54.0)	1.85 (47.0)
64	2	2.375 (60.3)	2.000 (50.8)	2.89 (73.4)	2 1/4 - 16 UN	2.500 (63.5)	2.500 (63.5)	1.85 (47.0)

Metric dimensions (mm) are in parentheses.