

1802/3802/4030/8866

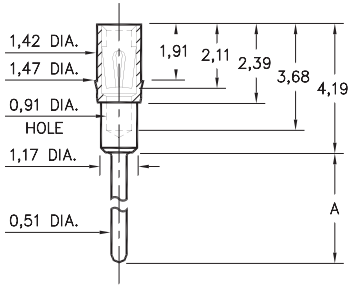

Basic Part Number	Length A
1802-0	3,18
3802-0	4,19
8866-0	19,69
4030-0	20,70

XXXX-0-15-XX-XX-XX-04-0
Press-fit in 1,45 mounting hole

1803/1805/1808/3805

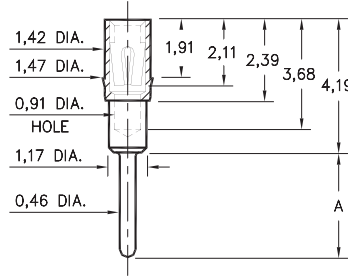

Basic Part Number	Length A
1808-0	2,54
1803-0	3,68
1805-0	5,41
3805-0	9,98

XXXX-0-15-XX-43-XX-04-0
Press-fit in 1,45 mounting hole

1804/1806

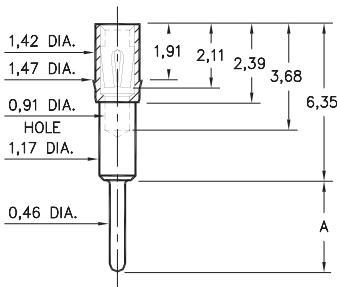

Basic Part Number	Length A
1804-0	2,03
1806-0	2,92

180X-0-15-XX-43-XX-04-0
Press-fit in 1,45 mounting hole

1807

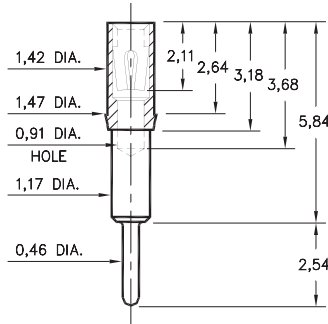

1807-0-15-XX-43-XX-04-0
Press-fit in 1,45 mounting hole

8830

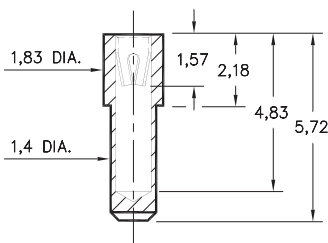

8830-0-15-XX-22-XX-10-0
Solder mount in 1,45 min. mounting hole

8363

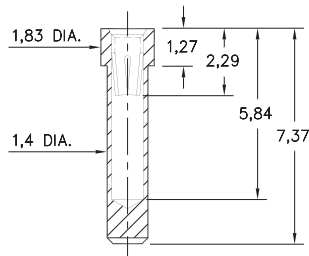

8363-0-15-XX-35-XX-10-0
Solder mount in 1,45 min. mounting hole

4622

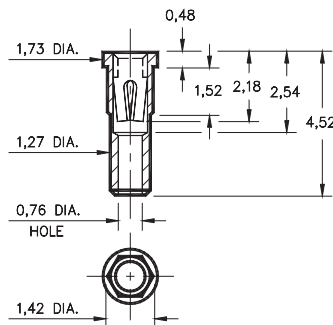

4622-0-15-XX-30-XX-10-0
Hex press-fit in 1,35 plated thru hole

6252

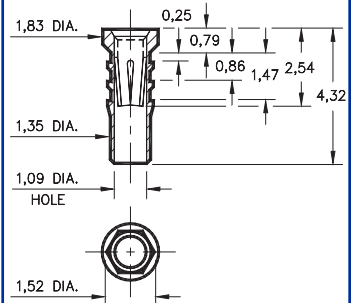

6252-0-15-XX-32-XX-10-0
Hex press-fit in 1,45 plated thru hole

SPECIFICATIONS

SHELL MATERIAL:
Brass Alloy 360, 1/2 Hard

CONTACT MATERIAL:
Beryllium Copper Alloy 172, HT

DIMENSION IN INCHES TOLERANCES ON:
LENGTHS: ±0,13
DIAMETERS: ±0,05
ANGLES: ± 2°

ORDER CODE: XXXX - X - 15 - XX - XX - XX - XX - 0

BASIC PART #

SPECIFY SHELL FINISH:
01 5,08µm TIN/LEAD OVER NICKEL
◇ 80 5,08µm TIN OVER NICKEL (RoHS)
◇ 15 0,25µm GOLD OVER NICKEL (RoHS)

SPECIFY CONTACT FINISH:
02 2,54µm TIN/LEAD OVER NICKEL
◇ 84 2,54µm TIN OVER NICKEL (RoHS)
◇ 27 0,76µm GOLD OVER NICKEL (RoHS)



SELECT CONTACT

#22, #30, #32 or #43 CONTACT (DATA ON PAGES 218, 219 & 220)