



# STA335BWQS

## 2.1-channel high-efficiency digital audio system with QSound QHD®

### Features

- Wide supply voltage range (4.5 V to 24 V)
  - 3 power output configurations
    - 2 channels of ternary PWM (stereo mode) (2 x 20 W into 8 Ω at 18 V), (2 x 37 W into 8 Ω at 24 V)
    - 3 channels - left, right using binary and LFE using ternary PWM (2.1 mode) (2 x 9 W + 1 x 20 W into 2 x 4 Ω, 1 x 8 Ω at 18 V)
    - 2 channels of ternary PWM (2 x 20 W) + stereo line-out ternary
  - 2.1 channels of 24-bit DDX®
  - 100-dB SNR and dynamic range
  - Selectable 32 kHz to 192 kHz input sample rates
  - I<sup>2</sup>C control with selectable device address
  - Digital gain/attenuation +48 dB to -80 dB in 0.5-dB steps
  - Soft volume update
  - Individual channel and master gain/attenuation
  - Dual independent limiters/compressors
  - Dynamic range compression or anti-clipping modes
  - AutoModes™ settings for:
    - 15 preset crossover filters
    - 2 preset anti-clipping modes
    - Preset night-time listening mode
  - Individual channel and master soft and hard mute
  - Independent channel volume and DSP bypass
  - Automatic zero-detect mute
- PowerSSO-36 slug down
- Automatic invalid input detect mute
  - 2-channel I<sup>2</sup>S input data interface
  - Input and output channel mapping
  - 4 x 28-bit user programmable biquads (EQ) per channel
  - Bass/treble tone control
  - DC blocking selectable high-pass filter
  - Selectable de-emphasis
  - Sub-channel mix into left and right channels
  - Advanced AM interference frequency switching and noise-suppression modes
  - Selectable high or low-bandwidth noise-shaping topologies
  - Variable max power correction for lower full-power THD
  - Selectable clock input ratio
  - 96 kHz internal processing sample rate, 24 to 28-bit precision
  - Thermal overload and short-circuit protection
  - Video application supports 576 x f<sub>s</sub> input mode
  - QSound QHD®
    - Field proven stereo soundfield enhancement technology
    - Provides improved audio image width, separation and depth for stereo signals
    - Synthesizes a 3-D stereo soundfield
  - PowerSSO-36 slug down package.

Table 1. Device summary

Order code	Package	Packaging
STA335BWQS	PowerSSO-36 slug down	Tube
STA335BWQS13TR	PowerSSO-36 slug down	Tape and reel

# Contents

<b>1</b>	<b>Description</b> .....	<b>10</b>
1.1	QSound® QHD® .....	10
1.2	Block diagram .....	11
<b>2</b>	<b>Pinout and thermal information</b> .....	<b>12</b>
2.1	Connection diagram .....	12
2.2	Pin description .....	12
2.3	Thermal data .....	14
<b>3</b>	<b>Electrical specifications</b> .....	<b>15</b>
3.1	Absolute maximum ratings .....	15
3.2	Recommended operating condition .....	15
3.3	Electrical specifications - digital section .....	16
3.4	Electrical specifications - power section .....	16
3.5	Power-on/off sequence .....	18
3.6	Testing .....	19
<b>4</b>	<b>Processing data paths</b> .....	<b>20</b>
<b>5</b>	<b>Functional description</b> .....	<b>21</b>
5.1	Functional pin status .....	21
5.1.1	Power-down function .....	21
5.1.2	Reset function .....	21
5.2	Serial audio interface description .....	22
5.2.1	Serial audio interface protocols .....	22
<b>6</b>	<b>I<sup>2</sup>C bus specification</b> .....	<b>23</b>
6.1	Communication protocol .....	23
6.1.1	Data transition or change .....	23
6.1.2	Start condition .....	23
6.1.3	Stop condition .....	23
6.1.4	Data input .....	23
6.2	Device addressing .....	23

6.3	Write operation . . . . .	24
6.3.1	Byte write . . . . .	24
6.3.2	Multi-byte write . . . . .	24
6.4	Read operation . . . . .	24
6.4.1	Current address byte read . . . . .	24
6.4.2	Current address multi-byte read . . . . .	24
6.4.3	Random address byte read . . . . .	24
6.4.4	Random address multi-byte read . . . . .	24
6.4.5	Write mode sequence . . . . .	25
6.4.6	Read mode sequence . . . . .	25
<b>7</b>	<b>Register description . . . . .</b>	<b>26</b>
7.1	Configuration register A (addr 0x00) . . . . .	27
7.1.1	Master clock select . . . . .	27
7.1.2	Interpolation ratio select . . . . .	28
7.1.3	Thermal warning recovery bypass . . . . .	29
7.1.4	Thermal warning adjustment bypass . . . . .	29
7.1.5	Fault detect recovery bypass . . . . .	29
7.2	Configuration register B (addr 0x01) . . . . .	30
7.2.1	Serial audio input interface format . . . . .	30
7.2.2	Serial data interface . . . . .	30
7.2.3	Serial data first bit . . . . .	30
7.2.4	Delay serial clock enable . . . . .	32
7.2.5	Channel input mapping . . . . .	32
7.3	Configuration register C (addr 0x02) . . . . .	33
7.3.1	DDX <sup>®</sup> power output mode . . . . .	33
7.3.2	DDX <sup>®</sup> compensating pulse size register . . . . .	33
7.3.3	Over-current warning detect adjustment bypass . . . . .	34
7.4	Configuration register D (addr 0x03) . . . . .	34
7.4.1	High-pass filter bypass . . . . .	34
7.4.2	De-emphasis . . . . .	34
7.4.3	DSP bypass . . . . .	34
7.4.4	Post-scale link . . . . .	35
7.4.5	Biquad coefficient link . . . . .	35
7.4.6	Dynamic range compression/anti-clipping bit . . . . .	35
7.4.7	Zero-detect mute enable . . . . .	35

7.4.8	MiamiMode enable	36
7.5	Configuration register E (addr 0x04)	36
7.5.1	Max power correction variable	36
7.5.2	Max power correction	36
7.5.3	Noise-shaper bandwidth selection	36
7.5.4	AM mode enable	37
7.5.5	PWM speed mode	37
7.5.6	Distortion compensation variable enable	37
7.5.7	Zero-crossing volume enable	37
7.5.8	Soft volume update enable	37
7.6	Configuration register F (addr 0x05)	38
7.6.1	Output configuration	38
7.6.2	Invalid input detect mute enable	42
7.6.3	Binary output mode clock loss detection	43
7.6.4	LRCK double trigger protection	43
7.6.5	Auto EAPD on clock loss	43
7.6.6	IC power down	43
7.6.7	External amplifier power down	43
7.7	Volume control registers (addr 0x06 to 0x0A)	44
7.7.1	Mute/line output configuration register	44
7.7.2	Master volume register	44
7.7.3	Channel 1 volume	44
7.7.4	Channel 2 volume	44
7.7.5	Channel 3 / line output volume	45
7.8	Auto mode registers (addr 0x0B and 0x0C)	46
7.8.1	AutoModes™ register 1 (0x0B)	46
7.8.2	AutoModes™ register 2 (0x0C)	46
7.8.3	AM interference frequency switching	47
7.8.4	Bass management crossover	47
7.9	Channel configuration registers (addr 0x0E to 0x10)	48
7.9.1	Tone control bypass	48
7.9.2	EQ bypass	48
7.9.3	Volume bypass	48
7.9.4	Binary output enable registers	49
7.9.5	Limiter select	49
7.9.6	Output mapping	49

7.10	Tone control register (addr 0x11) . . . . .	50
7.10.1	Tone control . . . . .	50
7.11	Dynamics control registers (addr 0x12 to 0x15) . . . . .	50
7.11.1	Limiter 1 attack/release rate . . . . .	50
7.11.2	Limiter 1 attack/release threshold . . . . .	50
7.11.3	Limiter 2 attack/release rate . . . . .	50
7.11.4	Limiter 2 attack/release threshold . . . . .	51
7.12	User-defined coefficient control registers (addr 0x16 to 0x26) . . . . .	55
7.12.1	Coefficient address register . . . . .	55
7.12.2	Coefficient b1 data register bits 23:16 . . . . .	55
7.12.3	Coefficient b1 data register bits 15:8 . . . . .	55
7.12.4	Coefficient b1 data register bits 7:0 . . . . .	55
7.12.5	Coefficient b2 data register bits 23:16 . . . . .	55
7.12.6	Coefficient b2 data register bits 15:8 . . . . .	56
7.12.7	Coefficient b2 data register bits 7:0 . . . . .	56
7.12.8	Coefficient a1 data register bits 23:16 . . . . .	56
7.12.9	Coefficient a1 data register bits 15:8 . . . . .	56
7.12.10	Coefficient a1 data register bits 7:0 . . . . .	56
7.12.11	Coefficient a2 data register bits 23:16 . . . . .	56
7.12.12	Coefficient a2 data register bits 15:8 . . . . .	56
7.12.13	Coefficient a2 data register bits 7:0 . . . . .	57
7.12.14	Coefficient b0 data register bits 23:16 . . . . .	57
7.12.15	Coefficient b0 data register bits 15:8 . . . . .	57
7.12.16	Coefficient b0 data register bits 7:0 . . . . .	57
7.12.17	Coefficient write/read control register . . . . .	57
7.12.18	User-defined EQ . . . . .	59
7.12.19	Pre-scale . . . . .	60
7.12.20	Post-scale . . . . .	60
7.12.21	Over-current post-scale . . . . .	60
7.13	Variable max power correction registers (addr 0x27 to 0x28) . . . . .	62
7.14	Variable distortion compensation registers (addr 0x29 to 0x2A) . . . . .	62
7.15	Fault detect recovery constant registers (addr 0x2B to 0x2C) . . . . .	62
7.16	Device status register (addr 0x2D) . . . . .	63
<b>8</b>	<b>Application . . . . .</b>	<b>64</b>
8.1	Application and power supplies . . . . .	64

---

8.2	PLL filter .....	64
8.3	Typical output configuration .....	65
<b>9</b>	<b>Package thermal characteristics .....</b>	<b>66</b>
<b>10</b>	<b>Package information .....</b>	<b>67</b>
<b>11</b>	<b>License information .....</b>	<b>69</b>
<b>12</b>	<b>Trademarks and other acknowledgements .....</b>	<b>70</b>
<b>13</b>	<b>Revision history .....</b>	<b>71</b>

# List of tables

Table 1.	Device summary . . . . .	1
Table 2.	Pin description . . . . .	12
Table 3.	Thermal data. . . . .	14
Table 4.	Absolute maximum ratings . . . . .	15
Table 5.	Recommended operating condition . . . . .	15
Table 6.	Electrical specifications - digital section . . . . .	16
Table 7.	Electrical specifications - power section . . . . .	16
Table 8.	Functional pin status. . . . .	21
Table 9.	Register summary. . . . .	26
Table 10.	MCS . . . . .	27
Table 11.	Input sampling rates . . . . .	28
Table 12.	IR . . . . .	28
Table 13.	IR bit settings as a function of input sample rate . . . . .	28
Table 14.	TWRB . . . . .	29
Table 15.	TWAB . . . . .	29
Table 16.	FDRB . . . . .	29
Table 17.	SAIn . . . . .	30
Table 18.	SAIFB . . . . .	30
Table 19.	Support serial audio input formats for MSB-first (SAIFB = 0) . . . . .	31
Table 20.	Supported serial audio input formats for LSB-first (SAIFB = 1) . . . . .	31
Table 21.	DSCKE . . . . .	32
Table 22.	CnIM . . . . .	32
Table 23.	OM . . . . .	33
Table 24.	Output modes . . . . .	33
Table 25.	CSZ. . . . .	33
Table 26.	Compensating pulse size . . . . .	33
Table 27.	OCRB . . . . .	34
Table 28.	HPB . . . . .	34
Table 29.	DEMP . . . . .	34
Table 30.	DSPB . . . . .	34
Table 31.	PSL . . . . .	35
Table 32.	BQL . . . . .	35
Table 33.	DRC . . . . .	35
Table 34.	ZDE. . . . .	35
Table 35.	MME . . . . .	36
Table 36.	MPCV . . . . .	36
Table 37.	MPC . . . . .	36
Table 38.	NSBW. . . . .	36
Table 39.	AME . . . . .	37
Table 40.	PWMS. . . . .	37
Table 41.	DCCV . . . . .	37
Table 42.	ZCE. . . . .	37
Table 43.	SVE. . . . .	37
Table 44.	OCFG . . . . .	38
Table 45.	Output configuration engine selection . . . . .	38
Table 46.	IDE . . . . .	42
Table 47.	BCLE . . . . .	43
Table 48.	LDTE. . . . .	43

Table 49.	ECLE .....	43
Table 50.	PWDN .....	43
Table 51.	EAPD .....	43
Table 52.	LOC description .....	44
Table 53.	Master volume offset as a function of MV[7:0] .....	45
Table 54.	Channel volume as a function of CnV[7:0] .....	45
Table 55.	AutoModes™ gain compression/limiters selection .....	46
Table 56.	AM enable .....	47
Table 57.	AutoModes™ AM switching frequency selection .....	47
Table 58.	Bass management crossover frequency .....	47
Table 59.	Channel limiter mapping as a function of CnLS bits .....	49
Table 60.	Channel output mapping as a function of CnOM bits .....	49
Table 61.	Tone control boost/cut as a function of BTC and TTC bits .....	50
Table 62.	Attack rate .....	52
Table 63.	Release rate .....	52
Table 64.	LnAT bits, anti-clipping .....	53
Table 65.	LnRT bits, anti-clipping .....	53
Table 66.	LnAT bits, dynamic range compression .....	54
Table 67.	LnRT bits, dynamic range compression .....	54
Table 68.	RAM block for biquads, mixing, scaling and bass setup .....	60
Table 69.	PowerSSO-36 slug down dimensions .....	68
Table 70.	Document revision history .....	71



# List of figures

Figure 1. Block diagram ..... 11

Figure 2. Pin connection PowerSSO-36 (top view) ..... 12

Figure 3. Power-on sequence ..... 18

Figure 4. Power-off sequence ..... 18

Figure 5. Test circuit 1 ..... 19

Figure 6. Test circuit 2 ..... 19

Figure 7. STA335BWQS processing data flow ..... 20

Figure 8. I<sup>2</sup>S ..... 22

Figure 9. Left justified ..... 22

Figure 10. Write mode sequence ..... 25

Figure 11. Read mode sequence ..... 25

Figure 12. OCFG = 00 (default value) ..... 39

Figure 13. OCFG = 01 ..... 39

Figure 14. OCFG = 10 ..... 39

Figure 15. OCFG = 11 ..... 39

Figure 16. Output mapping scheme ..... 39

Figure 17. 2.0 channels (OCFG = 00) PWM slots ..... 40

Figure 18. 2.1 channels (OCFG = 01) PWM slots ..... 41

Figure 19. 2.1 channels (OCFG = 10) PWM slots ..... 42

Figure 20. Basic limiter and volume flow diagram ..... 51

Figure 21. Application schematic ..... 64

Figure 22. PLL application schematic ..... 64

Figure 23. Output configuration for stereo BTL mode ..... 65

Figure 24. Double-layer PCB with copper ground area and 16 vias ..... 66

Figure 25. PowerSSO-36 power derating curves ..... 66

Figure 26. PowerSSO-36 slug down outline drawing ..... 67

# 1 Description

The STA335BWQS is an integration of digital audio processing, digital amplifier control, DDX<sup>®</sup> power-output stage and QSound QHD<sup>®</sup> technology to create a high-power single-chip DDX solution comprising high-quality, high-efficiency and all digital amplification.

The STA335BWQS is part of the Sound Terminal<sup>™</sup> family that provides full digital audio streaming to the speaker offering cost effectiveness, low energy dissipation and sound enrichment.

The STA335BWQS power section consists of four independent half-bridges. These can be configured via digital control to operate in different modes. 2.1 channels can be provided by two half-bridges and a single full-bridge, providing up to 2 x 9 W + 1 x 20 W of power output. Two channels can be provided by two full-bridges, providing up to 2 x 37 W of power. The IC can also be configured as 2.1 channels with 2 x 30 W provided by the device and external power for DDX<sup>®</sup> power drive.

Also provided in the STA335BWQS are a full assortment of digital processing features. This includes up to four programmable 28-bit biquads (EQ) per channel, and bass/treble tone control. AutoModes<sup>™</sup> enables a time-to-market advantage by substantially reducing the amount of software development needed for certain functions. This includes auto volume loudness, preset volume curves and preset EQ settings. There are also new advanced AM radio-interference reduction modes. The serial audio data input interface accepts all possible formats, including the popular I<sup>2</sup>S format. Three channels of DDX<sup>®</sup> processing are provided. This high-quality conversion from PCM audio to the DDX-patented 3-state PWM switching waveform provides over 100 dB SNR and dynamic range.

## 1.1 QSound<sup>®</sup> QHD<sup>®</sup>

Normally, reduced audio clarity is experienced due to the digital compression of music (and video-sound) combined with various audio processing techniques used in broadcast transmission. This is most apparent in products such as digital televisions and audio players. These devices are faced with a multitude of audio challenges, primarily associated with the small speakers, that are limited in location and cabinet housing, plus economized speaker drivers and components. As such, digital televisions and audio players are ideal candidates to benefit from stereo soundfield enhancement in order to deliver a full surround-like experience.

QSound QHD<sup>®</sup> and its industry recognized QXpander<sup>®</sup> technology is a field-proven stereo soundfield enhancement technology that provides a broader stereo image width with greater separation and depth for stereo signals and synthesizes a 3-D stereo soundfield. QHD<sup>®</sup> removes the small centralized audio sweet spot by creating a very wide stereo image with full surrounding audio. QHD<sup>®</sup> and its QXpander<sup>®</sup> technology have been incorporated into hundreds of QSound and third party hardware and software products, with total shipments in the millions.

## 1.2 Block diagram

Figure 1. Block diagram

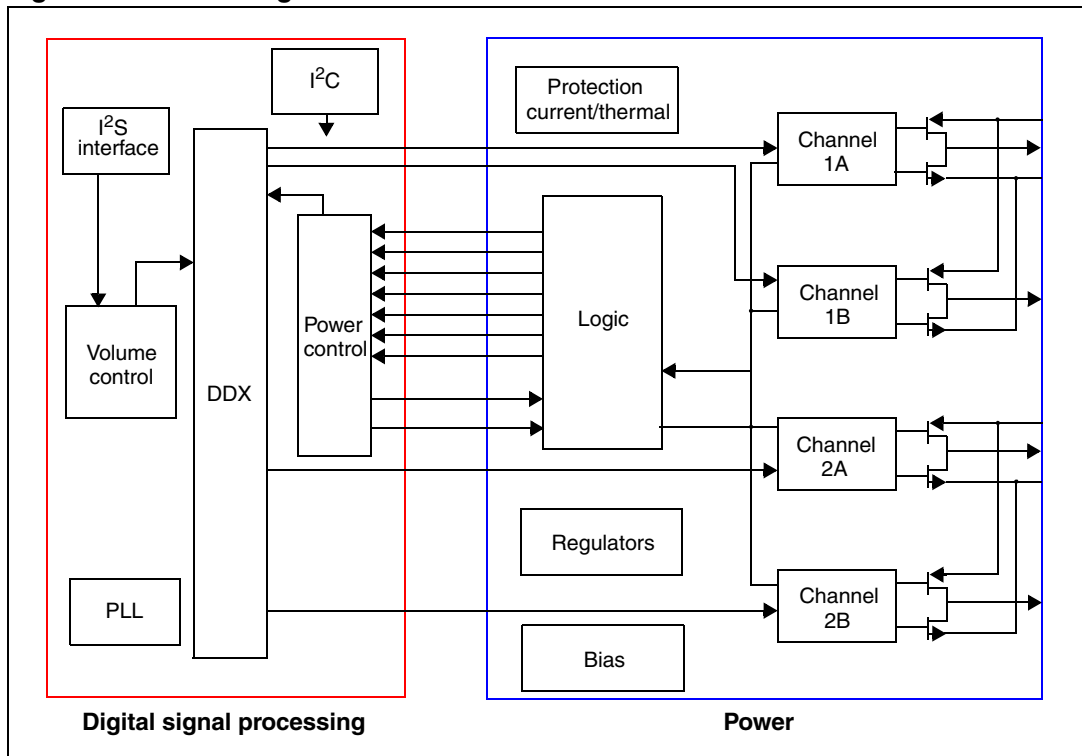

## 2 Pinout and thermal information

### 2.1 Connection diagram

Figure 2. Pin connection PowerSSO-36 (top view)

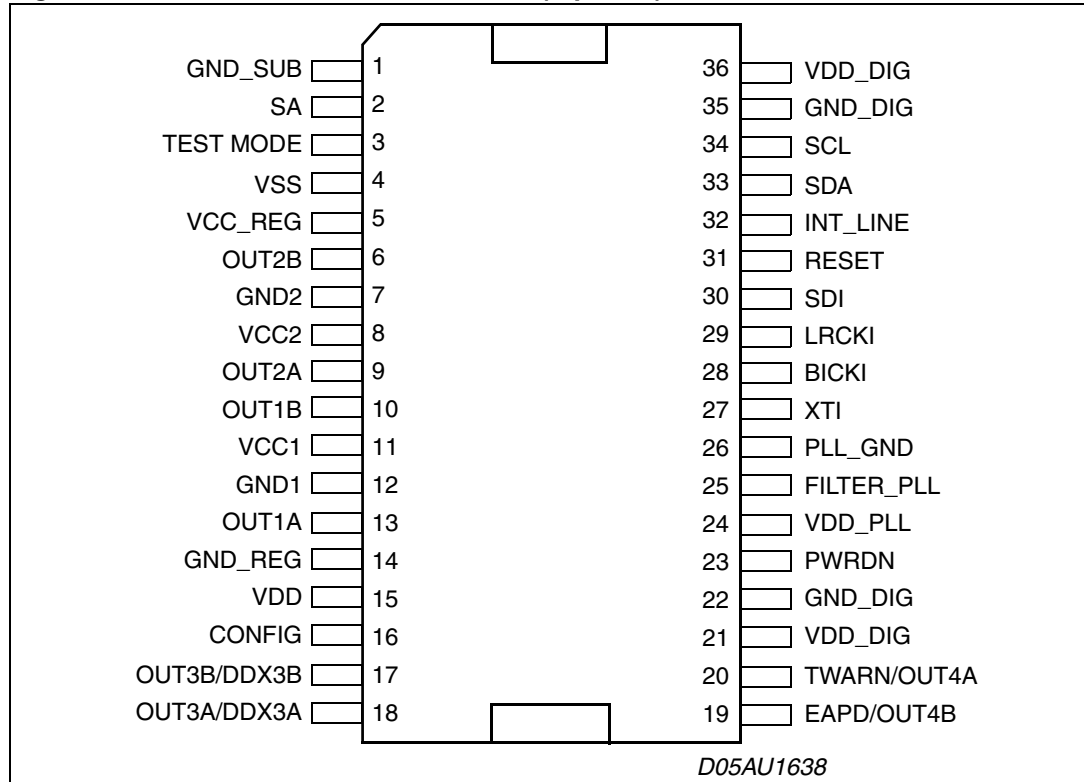

### 2.2 Pin description

Table 2. Pin description

Pin	Type	Name	Description
1	GND	GND_SUB	Substrate ground
2	I	SA	I <sup>2</sup> C select address
3	I	TEST_MODE	This pin must be connected to ground
4	I/O	VSS	Internal reference at Vcc - 3.3 V
5	I/O	VCC_REG	Internal Vcc reference
6	O	OUT2B	Output half bridge 2B
7	GND	GND2	Power negative supply
8	Power	VCC2	Power positive supply
9	O	OUT2A	Output half bridge 2A
10	O	OUT1B	Output half bridge 1B

Table 2. Pin description (continued)

Pin	Type	Name	Description
11	Power	VCC1	Power positive supply
12	GND	GND1	Power negative supply
13	I/O	OUT1A	Output half bridge 1A
14	GND	GND_REG	Internal ground reference
15	Power	VDD	Internal 3.3-V reference voltage
16	I	CONFIG	Paralleled mode command
17	O	OUT3B/DDX3B	PWM out CH3B - external bridge
18	O	OUT3A/DDX3A	PWM out CH3A - external bridge
19	O	EAPD/OUT4B	Power down for external bridge
20	I	TWARN/OUT4A	Thermal warning from external bridge
21	Power	VDD_DIG	Digital supply voltage
22	GND	GND_DIG	Digital ground
23	I	PWRDN	Power down
24	Power	VDD_PLL	Positive supply for PLL
25	I	FILTER_PLL	Connection to PLL filter
26	GND	GND_PLL	Negative supply for PLL
27	I	XTI	PLL input clock
28	I	BICKI	I <sup>2</sup> S serial clock
29	I	LRCKI	I <sup>2</sup> S left/right clock
30	I	SDI	I <sup>2</sup> C serial data channels 1 and 2
31	I	RESET	Reset
32	O	INT_LINE	Fault interrupt (0 = fault detected in the power bridge, 1 = normal operation)
33	I/O	SDA	I <sup>2</sup> C serial data
34	I	SCL	I <sup>2</sup> C serial clock
35	GND	GND_DIG	Digital ground
36	Power	VDD_DIG	Digital supply voltage

## 2.3 Thermal data

**Table 3. Thermal data**

	Parameter	Min	Typ	Max	Unit
$R_{th\ j-case}$	Thermal resistance junction-case (thermal pad)			1.5	°C/W
$T_{th-sdj}$	Thermal shut-down junction temperature	140	150	160	°C
$T_{th-w}$	Thermal warning temperature		130		°C
$T_{th-sdh}$	Thermal shut-down hysteresis	18	20	22	°C
$R_{th\ j-amb}$	Thermal resistance junction-ambient <sup>(1)</sup>				

1. See [Section 9: Package thermal characteristics on page 66](#) for details.

### 3 Electrical specifications

#### 3.1 Absolute maximum ratings

Table 4. Absolute maximum ratings

Symbol	Parameter	Min	Typ	Max	Unit
V <sub>cc</sub>	Power supply voltage (VCC1, VCC2)	-0.3		30	V
VDD_DIG	Digital supply voltage	-0.3		4	V
VDD_PLL	PLL supply voltage	-0.3		4	V
T <sub>op</sub>	Operating junction temperature	0		150	°C
T <sub>stg</sub>	Storage temperature	-40		150	°C

*Note:* Stresses beyond those listed under “Absolute maximum ratings” make cause permanent damage to the device. These are stress ratings only, and functional operation of the device at these or any other conditions beyond those indicated under “Recommended operating condition” are not implied. Exposure to absolute-maximum-rated conditions for extended periods may affect device reliability. In the real application, power supply with nominal value rated inside recommended operating conditions, may experience some rising beyond the maximum operating condition for short time when no or very low current is sinked (amplifier in mute state). In this case the reliability of the device is guaranteed, provided that the absolute maximum rating is not exceeded.

#### 3.2 Recommended operating condition

Table 5. Recommended operating condition

Symbol	Parameter	Min	Typ	Max	Unit
V <sub>cc</sub>	Power supply voltage (VCC1, VCC2)	4.5		24.0	V
VDD_DIG	Digital supply voltage	2.7	3.3	3.6	V
VDD_PLL	PLL supply voltage	2.7	3.3	3.6	V
T <sub>amb</sub>	Ambient temperature	0		70	°C

### 3.3 Electrical specifications - digital section

**Table 6. Electrical specifications - digital section**

Symbol	Parameter	Conditions	Min	Typ	Max	Unit
$I_{il}$	Low level input current without pull device	$V_i = 0\text{ V}$	-10		10	$\mu\text{A}$
$I_{ih}$	High level input current without pull device	$V_i = V_{DD\_DIG} = 3.6\text{ V}$	-10		10	$\mu\text{A}$
$V_{il}$	Low level input voltage				$0.2 \cdot V_{DD\_DIG}$	V
$V_{ih}$	High level input voltage		$0.8 \cdot V_{DD\_DIG}$			V
$V_{ol}$	Low level output voltage	$I_{ol} = 2\text{ mA}$			$0.4 \cdot V_{DD\_DIG}$	V
$V_{oh}$	High level output voltage	$I_{oh} = 2\text{ mA}$	$0.8 \cdot V_{DD\_DIG}$			V
$I_{pu}$	Pull current		-25	66	125	$\mu\text{A}$
$R_{pu}$	Equivalent pull resistance			50		$\text{k}\Omega$

### 3.4 Electrical specifications - power section

The specifications given in this section are with the operating conditions  $V_{CC} = 18\text{ V}$ ,  $f = 1\text{ kHz}$ ,  $f_{sw} = 384\text{ kHz}$ ,  $T_{amb} = 25^\circ\text{ C}$ ,  $R_L = 8\ \Omega$  unless otherwise specified

**Table 7. Electrical specifications - power section**

Symbol	Parameter	Conditions	Min	Typ	Max	Unit	
$P_o$	Output power BTL	THD = 1%		16		W	
		THD = 10%		20			
	Output power BTL	$V_{CC} = 24\text{ V}$	THD = 1%		29		W
			THD = 10%		37		
	Output power SE	$V_{CC} = 24\text{ V}$	THD = 1%		6.6		W
			THD = 10%		8.5		
Output power SE	$R_1 = 4\ \Omega$	THD = 1%		7		W	
		THD = 10%		9			
$R_{dsON}$	Power Pchannel/Nchannel MOSFET (total bridge)	$I_d = 1.5\text{ A}$		200	280	$\text{m}\Omega$	
$g_P$	Power Pchannel RdsON matching	$I_d = 1.5\text{ A}$	95			%	
$g_N$	Power Nchannel RdsON matching	$I_d = 1.5\text{ A}$	95			%	
$I_{dss}$	Power Pchannel/Nchannel leakage $I_{dss}$	$V_{CC} = 24\text{ V}$			10	$\mu\text{A}$	
$g_P$	Power Pchannel RdsON Matching	$I_d = 1.5\text{ A}$	95			%	
$g_N$	Power Nchannel RdsON Matching	$I_d = 1.5\text{ A}$	95			%	



**Table 7. Electrical specifications - power section (continued)**

Symbol	Parameter	Conditions	Min	Typ	Max	Unit
I <sub>DSS</sub>	Power Pchannel/Nchannel leakage	V <sub>CC</sub> = 24 V			10	μA
I <sub>LDT</sub>	Low current dead time (static)	Resistive load <sup>(1)</sup>		8	15	ns
I <sub>HDT</sub>	High current dead time (dynamic)	I <sub>load</sub> = 1.5 A <sup>(1)</sup>		15	30	ns
t <sub>r</sub>	Rise time	Resistive load <sup>(1)</sup>		10	18	ns
t <sub>f</sub>	Fall time	Resistive load <sup>(1)</sup>		10	18	ns
V <sub>CC</sub>	Supply voltage operating voltage		4.5		24	V
I <sub>CC</sub>	Supply current from Vcc in power down	PWRDN = 0		0.1	1	mA
	Supply current from Vcc in operation	PCM Input signal = -60 dBFS Switching frequency = 384 kHz No LC filters		30		mA
	Supply current DDX processing (reference only)	Internal clock = 49.152 MHz		80		mA
I <sub>lim</sub>	Over-current limit	<sup>(2)</sup>	3.0	3.8		A
I <sub>sc</sub>	Short circuit protection	Hi-Z output	3.8	4.8		A
UVL	Under voltage protection			3.5	4.3	V
t <sub>min</sub>	Output minimum pulse width	No load	20	30	60	ns
DR	Dynamic range			100		dB
SNR	Signal to noise ratio, ternary mode	A-Weighted		100		dB
	Signal to noise ratio binary mode			90		dB
PSSR	Power supply rejection ratio	DDX stereo mode, <5 kHz V <sub>RIPPLE</sub> = 1 V RMS Audio input = dither only		80		dB
THD+N	Total harmonic distortion + noise	DDX stereo mode, P <sub>o</sub> = 1 W f = 1 kHz		0.2		%
X <sub>TALK</sub>	Crosstalk	DDX stereo mode, <5 kHz One channel driven @ 1 W Other channel measured		80		dB
η	Peak efficiency, DDX mode	P <sub>o</sub> = 2 x 20 W into 8 Ω		90		%
	Peak efficiency, binary modes	P <sub>o</sub> = 2 x 9 W into 4 Ω, 1 x 20 W into 8 Ω		87		

1. Refer to [Figure 5: Test circuit 1](#).
2. Limit current if the register (OCRB par 6.1.3.3) over-current warning detect adjustment bypass is enabled. When disabled refer to the I<sub>sc</sub>.

### 3.5 Power-on/off sequence

Figure 3. Power-on sequence

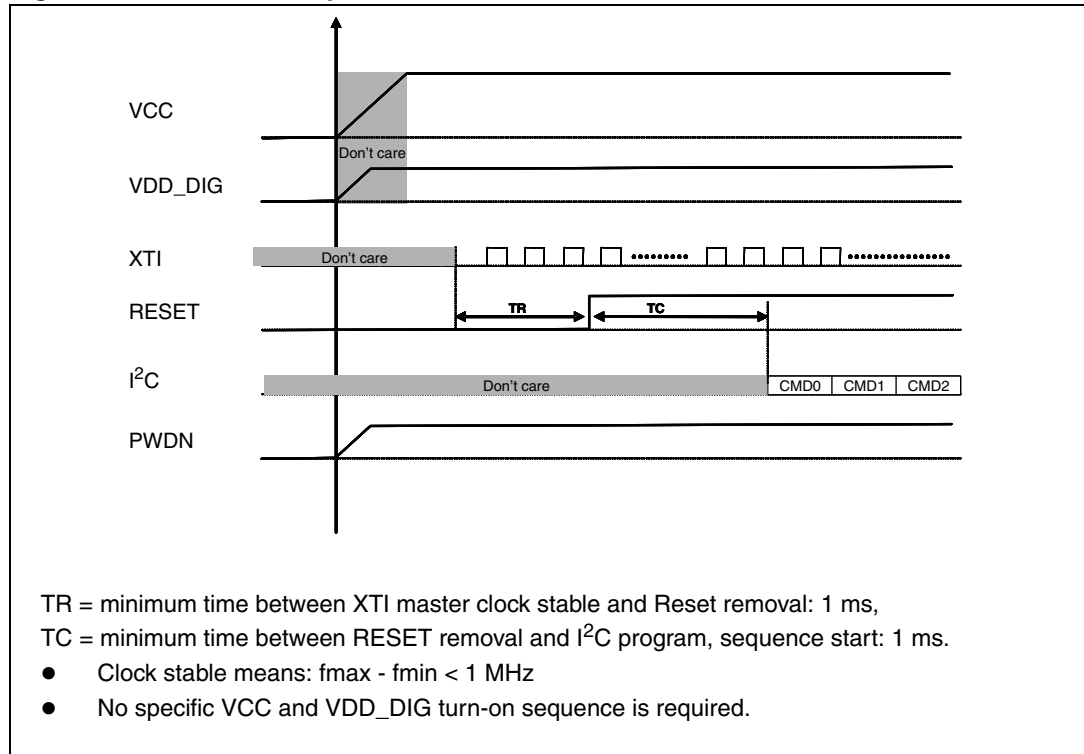
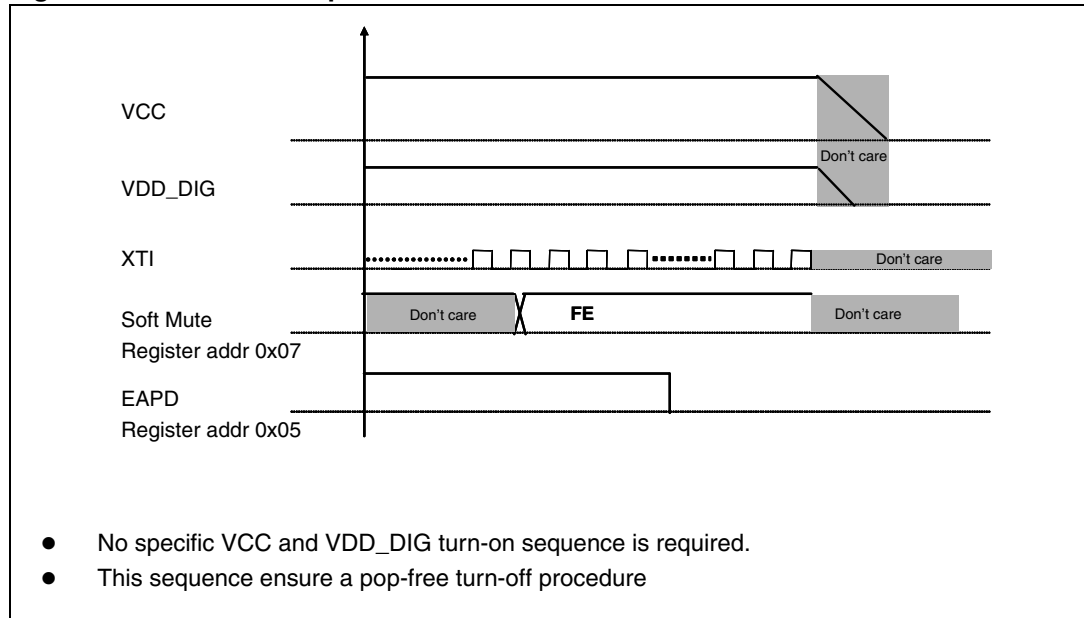

Figure 4. Power-off sequence



### 3.6 Testing

Figure 5. Test circuit 1

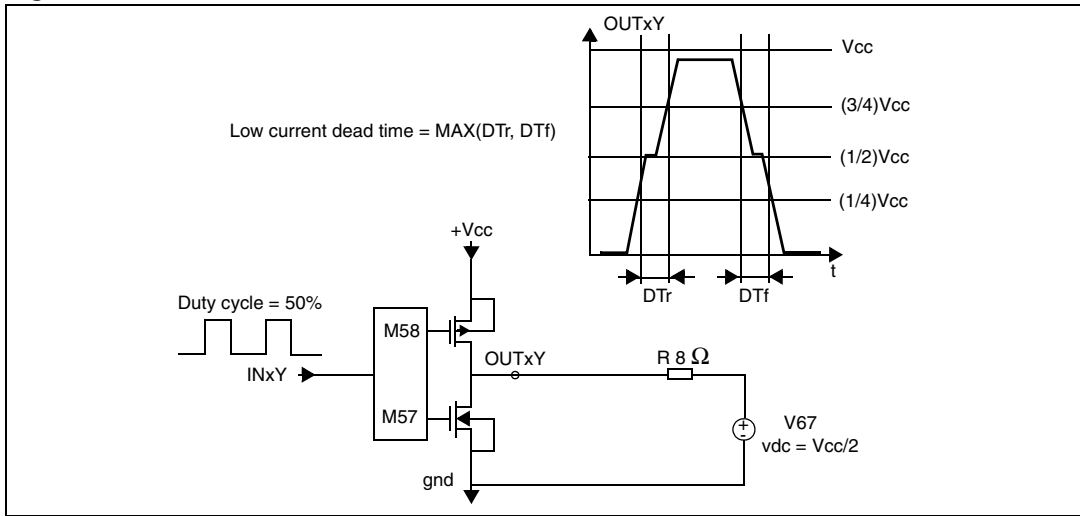
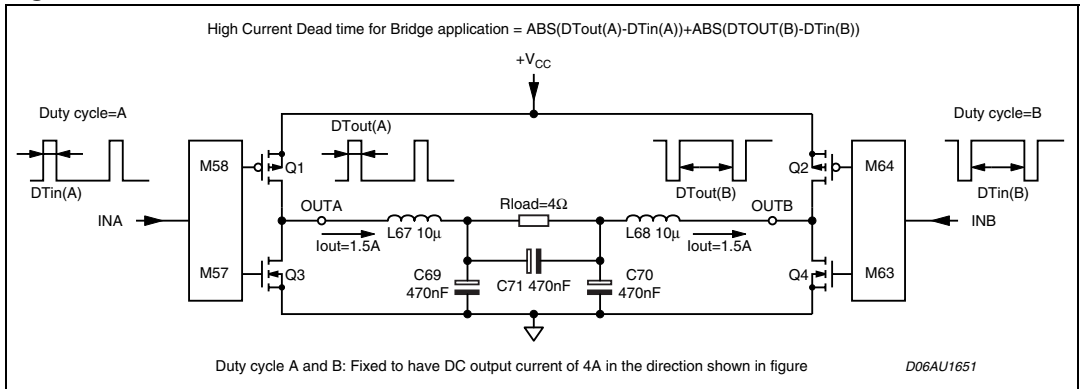

Figure 6. Test circuit 2



# 4 Processing data paths

Here are some diagrams that represent the data processing paths inside STA335BWQS. A 2-times oversampling FIR filter allows a  $2x f_s$  audio processing. Then a selectable high-pass filter removes the DC level. Four biquad filters allow a full equalization system. A final crossover filter is present. This filter can eventually be used as a fifth biquad stage, see the I<sup>2</sup>C registers settings for this specific usage. A prescaler and a final post scaler allow a full control over the signal dynamic respectively before and after the filtering stages. A mixer function is also available.

Figure 7. STA335BWQS processing data flow

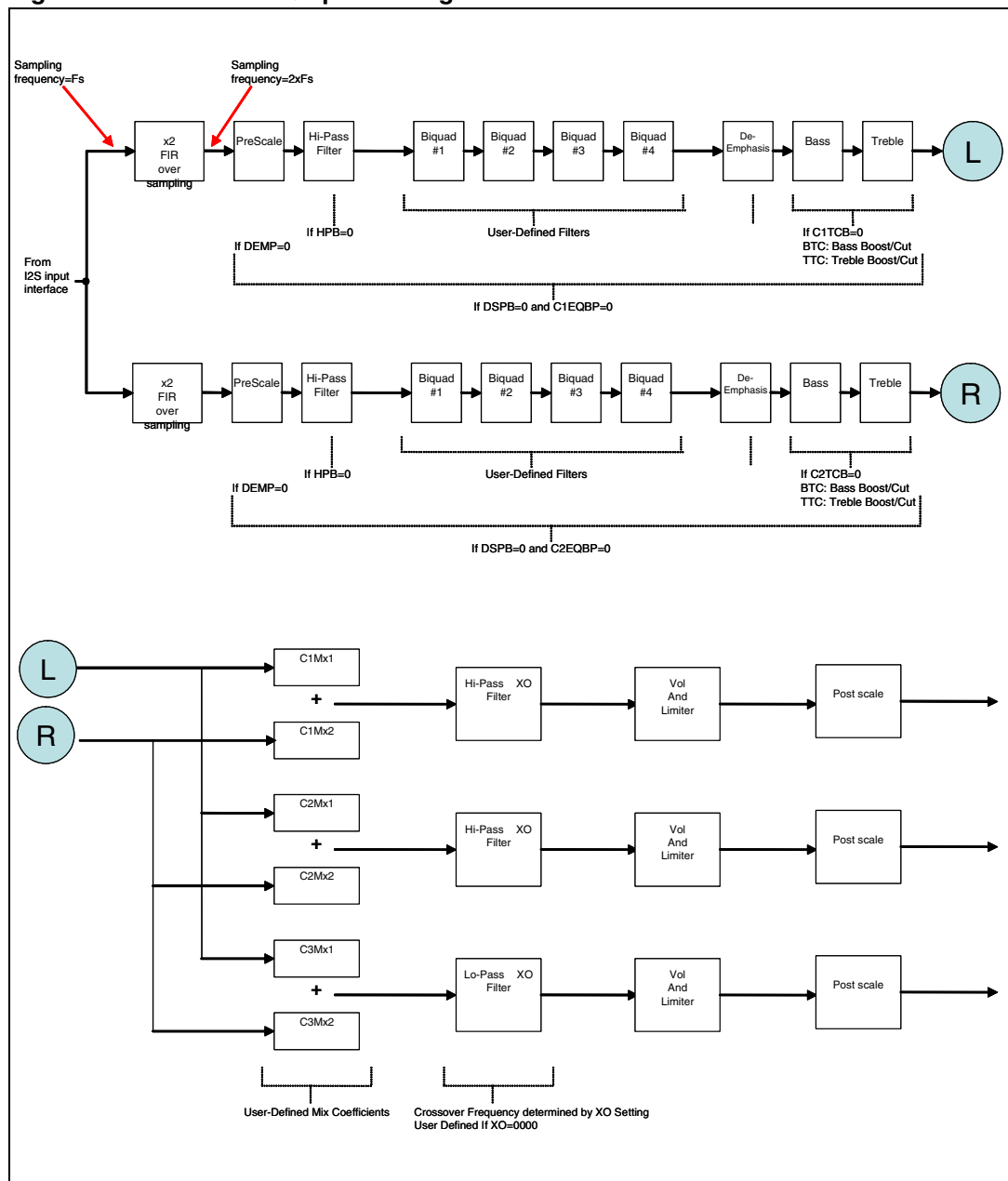

## 5 Functional description

### 5.1 Functional pin status

**Table 8. Functional pin status**

Pin name	Pin #	Logic value	IC status
RESET	31	0	Reset state: Power stage is switched off All the registers are set to default value
RESET	31	1	Normal operation
PWRDN	23	0	Low power mode: Power stage is switched off then the PLL is switched off (this operation take 13 million clock cycles)
PWRDN	23	1	Normal operation
TWARN	20	0	Temperature warning indication from external power stage
TWARN	20	1	Normal operation
EAPD	19	0	Low power mode for power stage: All internal regulators are switched off
EAPD	19	1	Normal operation

#### 5.1.1 Power-down function

Pin PWRDN (23) is used to power down the STA335BWQS.

PWRDN = 0 (GND) → Power down

PWRDN = 1 (VDD) → Normal operation

During the power-down sequence the output begins a gradual (soft) mute. After the mute condition is reached the power stage is switched off (Hi-Z) then the master clock to all internal hardware blocks is gated. The PLL is also switched off. The power-down sequence takes 13 million cycles.

#### 5.1.2 Reset function

Pin RESET (31) is used to reset the STA335BWQS.

RESET = 0 (GND) → Reset state

RESET = 1 (VDD) → Normal operation

When pin RESET is forced to 0 the power stage is switched off (Hi-Z) and the master clock to all internal hardware blocks is gated.

*Note: RESET condition takes priority over PWRDN condition.*

## 5.2 Serial audio interface description

### 5.2.1 Serial audio interface protocols

The STA335BWQS serial audio input interfaces with standard digital audio components and accepts serial data formats. The STA335BWQS always acts as a slave when receiving audio input from standard digital audio components. Serial data for two channels is provided using 3 input pins: left/right clock LRCKI (pin 29), serial clock BICKI (pin 28) and serial data SDI (pin 30).

Available formats are shown in [Figure 8](#) and [Figure 9](#). The format is set through Configuration register B (address 0x01).

**Figure 8. I<sup>2</sup>S**

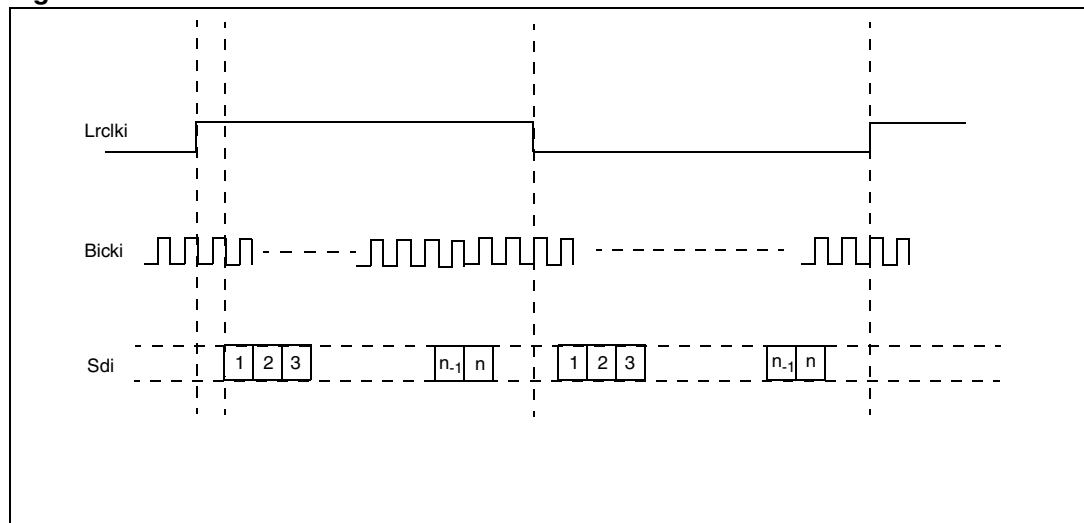

**Figure 9. Left justified**

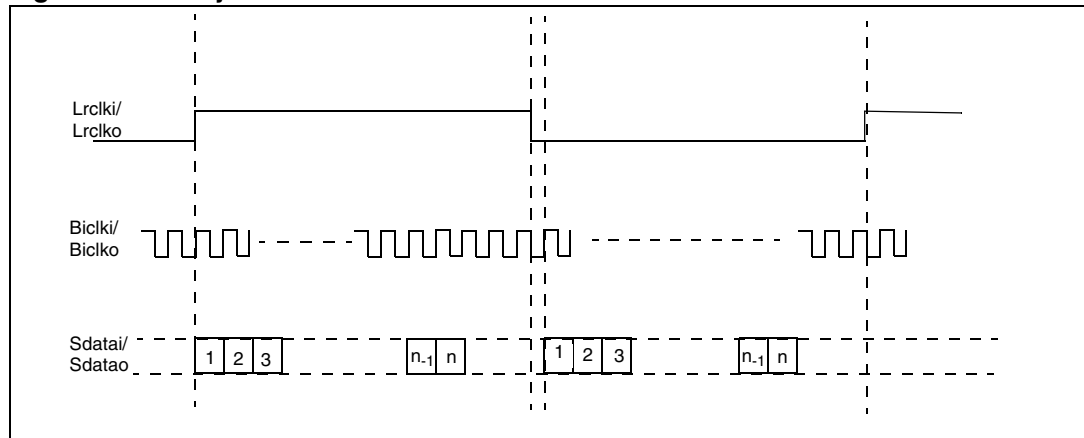

## 6 I<sup>2</sup>C bus specification

The STA335BWQS supports the I<sup>2</sup>C protocol via the input ports SCL and SDA\_IN (master to slave) and the output port SDA\_OUT (slave to master). This protocol defines any device that sends data on to the bus as a transmitter and any device that reads the data as a receiver. The device that controls the data transfer is known as the master and the other as the slave. The master always starts the transfer and provides the serial clock for synchronization. STA335BWQS is always a slave device in all of its communications. It supports up to 400 kb/s (fast-mode bit rate). STA335BWQS I<sup>2</sup>C is a slave only interface.

### 6.1 Communication protocol

#### 6.1.1 Data transition or change

Data changes on the SDA line must only occur when the SCL clock is low. SDA transition while the clock is high is used to identify a START or STOP condition.

#### 6.1.2 Start condition

START is identified by a high to low transition of the data bus SDA signal while the clock signal SCL is stable in the high state. A START condition must precede any command for data transfer.

#### 6.1.3 Stop condition

STOP is identified by low to high transition of the data bus SDA signal while the clock signal SCL is stable in the high state. A STOP condition terminates communication between STA335BWQS and the bus master.

#### 6.1.4 Data input

During the data input the STA335BWQS samples the SDA signal on the rising edge of clock SCL. For correct device operation the SDA signal must be stable during the rising edge of the clock and the data can change only when the SCL line is low.

### 6.2 Device addressing

To start communication between the master and the STA335BWQS, the master must initiate with a start condition. Following this, the master sends onto the SDA line 8-bits (MSB first) corresponding to the device select address and read or write mode.

The seven most significant bits are the device address identifiers, corresponding to the I<sup>2</sup>C bus definition. In the STA335BWQS the I<sup>2</sup>C interface has two device addresses depending on the SA port configuration, 0x38 when SA = 0, and 0x3A when SA = 1.

The eighth bit (LSB) identifies read or write operation RW, this bit is set to 1 in read mode and 0 for write mode. After a START condition the STA335BWQS identifies on the bus the device address and if a match is found, it acknowledges the identification on SDA bus during the 9th bit time. The byte following the device identification byte is the internal space address.

## 6.3 Write operation

Following the START condition the master sends a device select code with the RW bit set to 0. The STA335BWQS acknowledges this and the writes for the byte of internal address. After receiving the internal byte address the STA335BWQS again responds with an acknowledgement.

### 6.3.1 Byte write

In the byte write mode the master sends one data byte, this is acknowledged by the STA335BWQS. The master then terminates the transfer by generating a STOP condition.

### 6.3.2 Multi-byte write

The multi-byte write modes can start from any internal address. The master generating a STOP condition terminates the transfer.

## 6.4 Read operation

### 6.4.1 Current address byte read

Following the START condition the master sends a device select code with the RW bit set to 1. The STA335BWQS acknowledges this and then responds by sending one byte of data. The master then terminates the transfer by generating a STOP condition.

### 6.4.2 Current address multi-byte read

The multi-byte read modes can start from any internal address. Sequential data bytes are read from sequential addresses within the STA335BWQS. The master acknowledges each data byte read and then generates a STOP condition terminating the transfer.

### 6.4.3 Random address byte read

Following the START condition the master sends a device select code with the RW bit set to 0. The STA335BWQS acknowledges this and then the master writes the internal address byte. After receiving, the internal byte address the STA335BWQS again responds with an acknowledgement. The master then initiates another START condition and sends the device select code with the RW bit set to 1. The STA335BWQS acknowledges this and then responds by sending one byte of data. The master then terminates the transfer by generating a STOP condition.

### 6.4.4 Random address multi-byte read

The multi-byte read modes could start from any internal address. Sequential data bytes are read from sequential addresses within the STA335BWQS. The master acknowledges each data byte read and then generates a STOP condition terminating the transfer.



### 6.4.5 Write mode sequence

Figure 10. Write mode sequence

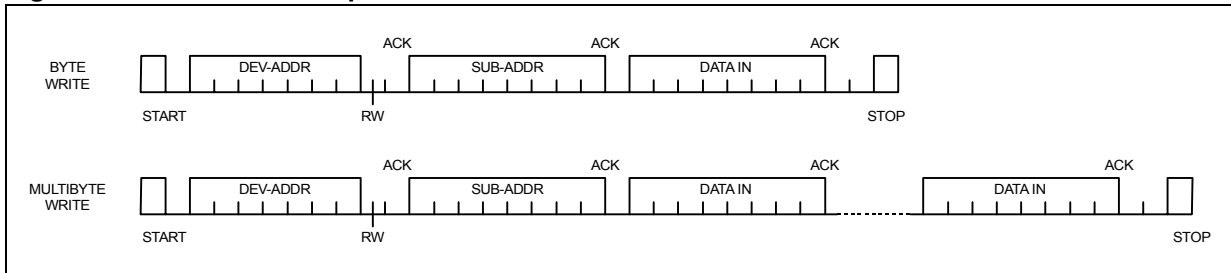

### 6.4.6 Read mode sequence

Figure 11. Read mode sequence

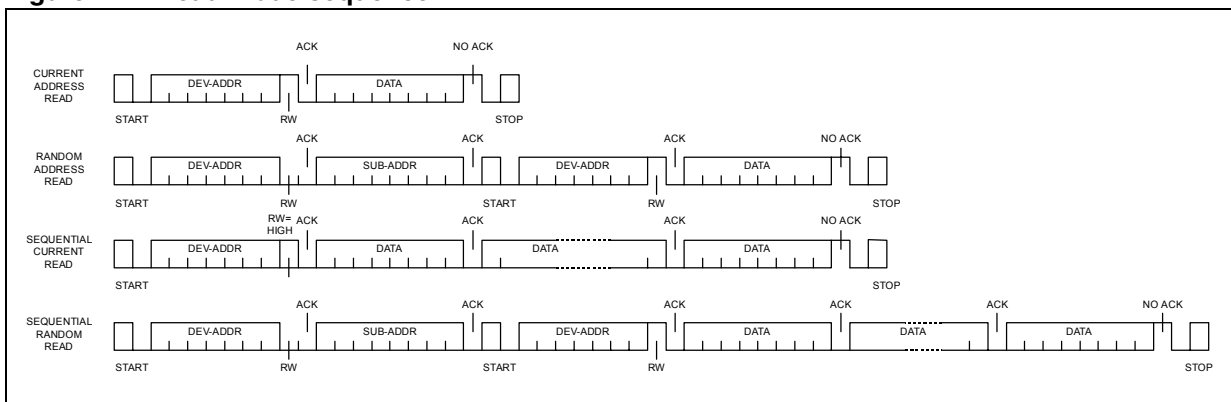

## 7 Register description

You must not reprogram the register bits marked “Reserved”. It is important that these bits keep their default reset values.

**Table 9. Register summary**

Addr	Name	D7	D6	D5	D4	D3	D2	D1	D0
0x00	ConfA	FDRB	TWAB	TWRB	IR1	IR0	MCS2	MCS1	MCS0
0x01	ConfB	C2IM	C1IM	DSCKE	SAIFB	SAI3	SAI2	SAI1	SAI0
0x02	ConfC	OCRB	Reserved	CSZ3	CSZ2	CSZ1	CSZ0	OM1	OM0
0x03	ConfD	MME	ZDE	DRC	BQL	PSL	DSPB	DEMP	HPB
0x04	ConfE	SVE	ZCE	DCCV	PWMS	AME	NSBW	MPC	MPCV
0x05	ConfF	EAPD	PWDN	ECLC	LDTE	BCLE	IDE	OCFG1	OCFG0
0x06	Mute/LOC	LOC1	LOC0	Reserved	Reserved	C3M	C2M	C1M	MMute
0x07	Mvol	MV7	MV6	MV5	MV4	MV3	MV2	MV1	MV0
0x08	C1Vol	C1V7	C1V6	C1V5	C1V4	C1V3	C1V2	C1V1	C1V0
0x09	C2Vol	C2V7	C2V6	C2V5	C2V4	C2V3	C2V2	C2V1	C2V0
0x0A	C3Vol	C3V7	C3V6	C3V5	C3V4	C3V3	C3V2	C3V1	C3V0
0x0B	Auto1	Reserved	Reserved	AMGC1	AMGC0	Reserved	Reserved	Reserved	Reserved
0x0C	Auto2	XO3	XO2	XO1	XO0	AMAM2	AMAM1	AMAM0	AMAME
0x0D	Auto3	Reserved	Reserved	Reserved	Reserved	Reserved	Reserved	Reserved	Reserved
0x0E	C1Cfg	C1OM1	C1OM0	C1LS1	C1LS0	C1BO	C1VBP	C1EQBP	C1TCB
0x0F	C2Cfg	C2OM1	C2OM0	C2LS1	C2LS0	C2BO	C2VBP	C2EQBP	C2TCB
0x10	C3Cfg	C3OM1	C3OM0	C3LS1	C3LS0	C3BO	C3VBP	Reserved	Reserved
0x11	Tone	TTC3	TTC2	TTC1	TTC0	BTC3	BTC2	BTC1	BTC0
0x12	L1ar	L1A3	L1A2	L1A1	L1A0	L1R3	L1R2	L1R1	L1R0
0x13	L1atrt	L1AT3	L1AT2	L1AT1	L1AT0	L1RT3	L1RT2	L1RT1	L1RT0
0x14	L2ar	L2A3	L2A2	L2A1	L2A0	L2R3	L2R2	L2R1	L2R0
0x15	L2atrt	L2AT3	L2AT2	L2AT1	L2AT0	L2RT3	L2RT2	L2RT1	L2RT0
0x16	Cfaddr	Reserved	Reserved	CFA5	CFA4	CFA3	CFA2	CFA1	CFA0
0x17	B1cf1	C1B23	C1B22	C1B21	C1B20	C1B19	C1B18	C1B17	C1B16
0x18	B1cf2	C1B15	C1B14	C1B13	C1B12	C1B11	C1B10	C1B9	C1B8
0x19	B1cf3	C1B7	C1B6	C1B5	C1B4	C1B3	C1B2	C1B1	C1B0
0x1A	B2cf1	C2B23	C2B22	C2B21	C2B20	C2B19	C2B18	C2B17	C2B16
0x1B	B2cf2	C2B15	C2B14	C2B13	C2B12	C2B11	C2B10	C2B9	C2B8
0x1C	B2cf3	C2B7	C2B6	C2B5	C2B4	C2B3	C2B2	C2B1	C2B0
0x1D	A1cf1	C3B23	C3B22	C3B21	C3B20	C3B19	C3B18	C3B17	C3B16

**Table 9. Register summary (continued)**

Addr	Name	D7	D6	D5	D4	D3	D2	D1	D0
0x1E	A1cf2	C3B15	C3B14	C3B13	C3B12	C3B11	C3B10	C3B9	C3B8
0x1F	A1cf3	C3B7	C3B6	C3B5	C3B4	C3B3	C3B2	C3B1	C3B0
0x20	A2cf1	C4B23	C4B22	C4B21	C4B20	C4B19	C4B18	C4B17	C4B16
0x21	A2cf2	C4B15	C4B14	C4B13	C4B12	C4B11	C4B10	C4B9	C4B8
0x22	A2cf3	C4B7	C4B6	C4B5	C4B4	C4B3	C4B2	C4B1	C4B0
0x23	B0cf1	C5B23	C5B22	C5B21	C5B20	C5B19	C5B18	C5B17	C5B16
0x24	B0cf2	C5B15	C5B14	C5B13	C5B12	C5B11	C5B10	C5B9	C5B8
0x25	B0cf3	C5B7	C5B6	C5B5	C5B4	C5B3	C5B2	C5B1	C5B0
0x26	Cfud	Reserved	Reserved	Reserved	Reserved	RA	R1	WA	W1
0x27	MPCC1	MPCC15	MPCC14	MPCC13	MPCC12	MPCC11	MPCC10	MPCC9	MPCC8
0x28	MPCC2	MPCC7	MPCC6	MPCC5	MPCC4	MPCC3	MPCC2	MPCC1	MPCC0
0x29	DCC1	DCC15	DCC14	DCC13	DCC12	DCC11	DCC10	DCC9	DCC8
0x2A	DCC2	DCC7	DCC6	DCC5	DCC4	DCC3	DCC2	DCC1	DCC0
0x2B	FDRC1	FDRC15	FDRC14	FDRC13	FDRC12	FDRC11	FDRC10	FDRC9	FDRC8
0x2C	FDRC2	FDRC7	FDRC6	FDRC5	FDRC4	FDRC3	FDRC2	FDRC1	FDRC0
0x2D	Status	PLLUL	FAULT	UVFAULT	OVFAULT	OCFAULT	OCWARN	TFAULT	TWARN
0x2E	Reserved	Reserved	Reserved	RO1BACT	R5BACT	R4BACT	R3BACT	R2BACT	R1BACT
0x2F	Reserved	Reserved	Reserved	R01BEND	R5BEND	R4BEND	R3BEND	R2BEND	R1BEND
0x30	Reserved	Reserved	Reserved	Reserved	R5BBAD	R4BBAD	R3BBAD	R2BBAD	R1BBAD

## 7.1 Configuration register A (addr 0x00)

D7	D6	D5	D4	D3	D2	D1	D0
FDRB	TWAB	TWRB	IR1	IR0	MCS2	MCS1	MCS0
0	1	1	0	0	0	1	1

### 7.1.1 Master clock select

**Table 10. MCS**

Bit	R/W	RST	Name	Description
0	RW	1	MCS0	Selects the ratio between the input I <sup>2</sup> S sample frequency and the input clock.
1	RW	1	MCS1	
2	RW	0	MCS2	

The STA335BWQS supports sample rates of 32 kHz, 44.1 kHz, 48 kHz, 88.2 kHz, 96 kHz, 176.4 kHz, and 192 kHz. Therefore the internal clock is:

- 32.768 MHz for 32 kHz
- 45.1584 MHz for 44.1 kHz, 88.2 kHz, and 176.4 kHz
- 49.152 MHz for 48 kHz, 96 kHz, and 192 kHz

The external clock frequency provided to the XTI pin must be a multiple of the input sample frequency ( $f_s$ ).

The relationship between the input clock and the input sample rate is determined by both the MCSx and the IR (input rate) register bits. The MCSx bits determine the PLL factor generating the internal clock and the IR bit determines the oversampling ratio used internally

**Table 11. Input sampling rates**

Input sample rate $f_s$ (kHz)	IR	MCS[2:0]					
		101	100	011	010	001	000
32, 44.1, 48	00	576 x $f_s$	128 x $f_s$	256 x $f_s$	384 x $f_s$	512 x $f_s$	768 x $f_s$
88.2, 96	01	NA	64 x $f_s$	128 x $f_s$	192 x $f_s$	256 x $f_s$	384 x $f_s$
176.4, 192	1X	NA	32 x $f_s$	64 x $f_s$	96 x $f_s$	128 x $f_s$	192 x $f_s$

## 7.1.2 Interpolation ratio select

**Table 12. IR**

Bit	R/W	RST	Name	Description
4:3	RW	00	IR [1:0]	Selects internal interpolation ratio based on input I <sup>2</sup> S sample frequency

The STA335BWQS has variable interpolation (oversampling) settings such that internal processing and DDX<sup>®</sup> output rates remain consistent. The first processing block interpolates by either 2 times or 1 time (pass-through) or provides a 2-times downsample. The oversampling ratio of this interpolation is determined by the IR bits.

**Table 13. IR bit settings as a function of input sample rate**

Input sample rate $f_s$ (kHz)	IR	1st stage interpolation ratio
32	00	2 times oversampling
44.1	00	2 times oversampling
48	00	2 times oversampling
88.2	01	Pass-through
96	01	Pass-through
176.4	10	2 times downsampling
192	10	2 times downsampling

### 7.1.3 Thermal warning recovery bypass

Table 14. TWRB

Bit	R/W	RST	Name	Description
5	RW	1	TWRB	0: Thermal warning recovery enabled 1: Thermal warning recovery disabled

If the thermal warning adjustment is enabled (TWAB = 0), then the thermal warning recovery determines if the -3 dB output limit is removed when thermal warning is negative.

If TWRB = 0 and TWAB = 0 then, when a thermal warning disappears, the -3 dB output limit is removed and the gain is added back to the system. If TWRB = 1 and TWAB = 0, then when a thermal warning disappears the -3 dB output limit remains until TWRB is changed to zero or the device is reset.

### 7.1.4 Thermal warning adjustment bypass

Table 15. TWAB

Bit	R/W	RST	Name	Description
6	RW	1	TWAB	0: Thermal warning adjustment enabled 1: Thermal warning adjustment disabled

The on-chip STA335BWQS power output block provides feedback to the digital controller using inputs to the power control block. The TWARN input is used to indicate a thermal warning condition. When TWARN is asserted (set to 0) for a period of time greater than 400 ms, the power control block forces a -3 dB output limit (determined by TWOCL in coefficients RAM) to the modulation limit in an attempt to eliminate the thermal warning condition. Once the thermal warning output limit adjustment is applied, it remains in this state until reset, unless FDRB = 0.

### 7.1.5 Fault detect recovery bypass

Table 16. FDRB

Bit	R/W	RST	Name	Description
7	RW	0	FDRB	0: fault detect recovery enabled 1: fault detect recovery disabled

The on-chip STA335BWQS power output block provides feedback to the digital controller using inputs to the power control block. The FAULT input is used to indicate a fault condition (either over-current or thermal). When FAULT is asserted (set to 0), the power control block attempts a recovery from the fault by asserting the 3-state output (setting it to 0 which directs the power output block to begin recovery), holds it at 0 for period of time in the range of 0.1 ms to 1 s as defined by the fault-detect recovery constant register (FDRB registers 0x29, 0x2A), then toggles it back to 1. This sequence is repeated as long as the fault indication exists. This feature is enabled by default but can be bypassed by setting the FDRB control bit to 1.

## 7.2 Configuration register B (addr 0x01)

D7	D6	D5	D4	D3	D2	D1	D0
C2IM	C1IM	DSCKE	SAIFB	SAI3	SAI2	SAI1	SAI0
1	0	0	0	0	0	0	0

### 7.2.1 Serial audio input interface format

Table 17. SAI<sub>n</sub>

Bit	R/W	RST	Name	Description
0	RW	0	SAI0	Determines the interface format of the input serial digital audio interface.
1	RW	0	SAI1	
2	RW	0	SAI2	
3	RW	0	SAI3	

### 7.2.2 Serial data interface

The STA335BWQS audio serial input was designed to interface with standard digital audio components and to accept a number of serial data formats. STA335BWQS always acts a slave when receiving audio input from standard digital audio components. Serial data for two channels is provided using three inputs: left/right clock LRCKI, serial clock BICKI, and serial data 1 and 2 SDI12.

The SAI register (configuration register B (0x01), bits D3 to D0) and the SAIFB register (configuration register B (0x01), bit D4) are used to specify the serial data format. The default serial data format is I<sup>2</sup>S, MSB first. Available formats are shown in the tables and figure that follow.

### 7.2.3 Serial data first bit

Table 18. SAIFB

SAIFB	Format
0	MSB first
1	LSB first

**Table 19. Support serial audio input formats for MSB-first (SAIFB = 0)**

BICKI	SAI [3:0]	SAIFB	Interface format
32fs	0000	0	I <sup>2</sup> S 15-bit data
	0001	0	Left/right-justified 16-bit data
48fs	0000	0	I <sup>2</sup> S 16 to 23-bit data
	0001	0	Left-justified 16 to 24-bit data
	0010	0	Right-justified 24-bit data
	0110	0	Right-justified 20-bit data
	1010	0	Right-justified 18-bit data
	1110	0	Right-justified 16-bit data
64fs	0000	0	I <sup>2</sup> S 16 to 24-bit data
	0001	0	Left-justified 16 to 24-bit data
	0010	0	Right-justified 24-bit data
	0110	0	Right-justified 20-bit data
	1010	0	Right-justified 18-bit data
	1110	0	Right-justified 16-bit data

**Table 20. Supported serial audio input formats for LSB-first (SAIFB = 1)**

BICKI	SAI [3:0]	SAIFB	Interface Format
32fs	1100	1	I <sup>2</sup> S 15-bit data
	1110	1	Left/right-justified 16-bit data
48fs	0100	1	I <sup>2</sup> S 23-bit data
	0100	1	I <sup>2</sup> S 20-bit data
	1000	1	I <sup>2</sup> S 18-bit data
	1100	1	LSB first I <sup>2</sup> S 16-bit data
	0001	1	Left-justified 24-bit data
	0101	1	Left-justified 20-bit data
	1001	1	Left-justified 18-bit data
	1101	1	Left-justified 16-bit data
	0010	1	Right-justified 24-bit data
	0110	1	Right-justified 20-bit data
	1010	1	Right-justified 18-bit data
	1110	1	Right-justified 16-bit data

Table 20. Supported serial audio input formats for LSB-first (SAIFB = 1) (continued)

BICKI	SAI [3:0]	SAIFB	Interface Format
64fs	0000	1	I <sup>2</sup> S 24-bit data
	0100	1	I <sup>2</sup> S 20-bit data
	1000	1	I <sup>2</sup> S 18-bit data
	1100	1	LSB first I <sup>2</sup> S 16-bit data
	0001	1	Left-justified 24-bit data
	0101	1	Left-justified 20-bit data
	1001	1	Left-justified 18-bit data
	1101	1	Left-justified 16-bit data
	0010	1	Right-justified 24-bit data
	0110	1	Right-justified 20-bit data
	1010	1	Right-justified 18-bit data
	1110	1	Right-justified 16-bit data

## 7.2.4 Delay serial clock enable

Table 21. DSCKE

Bit	R/W	RST	Name	Description
5	RW	0	DSCKE	0: No serial clock delay 1: Serial clock delay by 1 core clock cycle to tolerate anomalies in some I <sup>2</sup> S master devices

## 7.2.5 Channel input mapping

Table 22. CnIM

Bit	R/W	RST	Name	Description
6	RW	0	C1IM	0: Processing channel 1 receives Left I <sup>2</sup> S Input 1: Processing channel 1 receives Right I <sup>2</sup> S Input
7	RW	1	C2IM	0: Processing channel 2 receives Left I <sup>2</sup> S Input 1: Processing channel 2 receives Right I <sup>2</sup> S Input

Each channel received via I<sup>2</sup>S can be mapped to any internal processing channel via the channel input mapping registers. This allows for flexibility in processing. The default settings of these registers map each I<sup>2</sup>S input channel to its corresponding processing channel.



### 7.3 Configuration register C (addr 0x02)

D7	D6	D5	D4	D3	D2	D1	D0
OCRB	Reserved	CSZ3	CSZ2	CSZ1	CSZ0	OM1	OM0
1	0	0	1	0	1	1	1

#### 7.3.1 DDX<sup>®</sup> power output mode

Table 23. OM

Bit	R/W	RST	Name	Description
0	RW	1	OM0	Selects configuration of DDX output.
1	RW	1	OM1	

The DDX power output mode selects how the DDX output timing is configured. Different power devices use different output modes.

Table 24. Output modes

OM[1,0]	Output stage - mode
00	Drop compensation
01	Discrete output stage - tapered compensation
10	Full power mode
11	Variable drop compensation (CSZx bits)

#### 7.3.2 DDX<sup>®</sup> compensating pulse size register

Table 25. CSZ

Bit	R/W	RST	Name	Description
2	RW	1	CSZ0	When OM[1,0] = 11, this register determines the size of the DDX compensating pulse from 0 clock ticks to 15 clock periods.
3	RW	0	CSZ1	
4	RW	1	CSZ2	
5	RW	0	CSZ3	

Table 26. Compensating pulse size

CSZ[3:0]	Compensating Pulse Size
0000	0 ns (0 ticks) compensating pulse size
0001	20 ns (1 tick) clock period compensating pulse size
...	...
1111	300 ns (15 ticks) clock period compensating pulse size

### 7.3.3 Over-current warning detect adjustment bypass

**Table 27. OCRB**

Bit	R/W	RST	Name	Description
7	RW	1	OCRB	0: Over-current warning adjustment enabled 1: Over-current warning adjustment disabled

The OCWARN input is used to indicate an over-current warning condition. When OCWARN is asserted (set to 0), the power control block forces an adjustment to the modulation limit (default is -3 dB) in an attempt to eliminate the over-current warning condition. Once the over-current warning volume adjustment is applied, it remains in this state until reset is applied. The level of adjustment can be changed via the TWOCL (thermal warning/over current limit) setting which is address 0x37 of the user defined coefficient RAM.

## 7.4 Configuration register D (addr 0x03)

D7	D6	D5	D4	D3	D2	D1	D0
MME	ZDE	DRC	BQL	PSL	DSPB	DEMP	HPB
0	1	0	0	0	0	0	0

### 7.4.1 High-pass filter bypass

**Table 28. HPB**

Bit	R/W	RST	Name	Description
0	RW	0	HPB	Setting of one bypasses internal AC coupling digital high-pass filter

The STA335BWQS features an internal digital high-pass filter for the purpose of AC coupling. The purpose of this filter is to prevent DC signals from passing through a DDX amplifier. DC signals can cause speaker damage. When HPB = 0, this filter is enabled.

### 7.4.2 De-emphasis

**Table 29. DEMP**

Bit	R/W	RST	Name	Description
1	RW	0	DEMP	0: No de-emphasis 1: De-emphasis

Setting the DEMP bit enables de-emphasis on all channels

### 7.4.3 DSP bypass

**Table 30. DSPB**

Bit	R/W	RST	Name	Description
2	RW	0	DSPB	0: Normal operation 1: Bypass of biquad and bass/treble function

Setting the DSPB bit bypasses the EQ function of the STA335BWQS.

### 7.4.4 Post-scale link

Table 31. PSL

Bit	R/W	RST	Name	Description
3	RW	0	PSL	0: Each channel uses individual post-scale value 1: Each channel uses channel 1 post-scale value

Post-scale functionality can be used for power-supply error correction. For multi-channel applications running off the same power-supply, the post-scale values can be linked to the value of channel 1 for ease of use and update the values faster.

### 7.4.5 Biquad coefficient link

Table 32. BQL

Bit	R/W	RST	Name	Description
4	RW	0	BQL	0: Each channel uses coefficient values 1: Each channel uses channel 1 coefficient values

For ease of use, all channels can use the biquad coefficients loaded into the channel 1 coefficient RAM space by setting bit BQL to 1. Therefore, any EQ updates only have to be performed once.

### 7.4.6 Dynamic range compression/anti-clipping bit

Table 33. DRC

Bit	R/W	RST	Name	Description
5	RW	0	DRC	0: Limiters act in anti-clipping mode 1: Limiters act in dynamic range compression mode

Both limiters can be used in one of two ways, anti-clipping or dynamic range compression. When used in anti-clipping mode the limiter threshold values are constant and dependent on the limiter settings. In dynamic range compression mode the limiter threshold values vary with the volume settings allowing a nighttime listening mode that provides a reduction in the dynamic range regardless of the volume level.

### 7.4.7 Zero-detect mute enable

Table 34. ZDE

Bit	R/W	RST	Name	Description
6	RW	1	ZDE	Setting of 1 enables the automatic zero-detect mute

Setting the ZDE bit enables the zero-detect automatic mute. The zero-detect circuit looks at the data for each processing channel at the output of the crossover (bass management) filter. If any channel receives 2048 consecutive zero value samples (regardless of fs) then that individual channel is muted if this function is enabled.

### 7.4.8 MiamiMode enable

Table 35. MME

Bit	R/W	RST	Name	Description
7	RW	0	MME	0: Sub mix into left/right disabled 1: Sub mix into left/right enabled

## 7.5 Configuration register E (addr 0x04)

D7	D6	D5	D4	D3	D2	D1	D0
SVE	ZCE	DCCV	PWMS	AME	NSBW	MPC	MPCV
1	1	0	0	0	0	1	0

### 7.5.1 Max power correction variable

Table 36. MPCV

Bit	R/W	RST	Name	Description
0	RW	0	MPCV	0: Use standard MPC coefficient 1: Use MPCC bits for MPC coefficient

### 7.5.2 Max power correction

Table 37. MPC

Bit	R/W	RST	Name	Description
1	RW	1	MPC	Setting of 1 enables Power Bridge correction for THD reduction near maximum power output.

Setting the MPC bit turns on special processing that corrects the STA335BW power device at high power. This mode should lower the THD+N of a full DDX system at maximum power output and slightly below. If enabled, MPC is operational in all output modes except tapered (OM[1,0] = 01) and binary. When OCFG = 00, MPC will not effect channels 3 and 4, the line-out channels.

### 7.5.3 Noise-shaper bandwidth selection

Table 38. NSBW

Bit	R/W	RST	Name	Description
2	RW	0	NSBW	1: Third-order NS 0: Fourth-order NS

### 7.5.4 AM mode enable

Table 39. AME

Bit	R/W	RST	Name	Description
3	RW	0	AME	0: Normal DDX operation. 1: AM reduction mode DDX operation

STA335BWQS features a DDX processing mode that minimizes the amount of noise generated in frequency range of AM radio. This mode is intended for use when DDX is operating in a device with an AM tuner active. The SNR of the DDX processing is reduced to ~83 dB in this mode, which is still greater than the SNR of AM radio.

### 7.5.5 PWM speed mode

Table 40. PWMS

Bit	R/W	RST	Name	Description
4	RW	0	PWMS	0: Normal speed (384 kHz) all channels 1: Odd speed (341.3 kHz) all channels

### 7.5.6 Distortion compensation variable enable

Table 41. DCCV

Bit	R/W	RST	Name	Description
5	RW	0	DCCV	0: Uses preset DC coefficient 1: Uses DCC coefficient

### 7.5.7 Zero-crossing volume enable

Table 42. ZCE

Bit	R/W	RST	Name	Description
6	RW	1	ZCE	1: Volume adjustments only occur at digital zero-crossings 0: Volume adjustments occur immediately

The ZCE bit enables zero-crossing volume adjustments. When volume is adjusted on digital zero-crossings no clicks are audible.

### 7.5.8 Soft volume update enable

Table 43. SVE

Bit	R/W	RST	Name	Description
7	RW	1	SVE	1: Volume adjustments ramp according to SVR settings 0: Volume adjustments occur immediately

## 7.6 Configuration register F (addr 0x05)

D7	D6	D5	D4	D3	D2	D1	D0
EAPD	PWDN	ECLE	LDTE	BCLE	IDE	OCFG1	OCFG0
0	1	0	1	1	1	0	0

### 7.6.1 Output configuration

**Table 44. OCFG**

Bit	R/W	RST	Name	Description
0	RW	0	OCFG0	Selects the output configuration
1	RW	0	OCFG1	

**Table 45. Output configuration engine selection**

OCFG[1:0]	Output configuration	Config pin
00	2-channel (full-bridge) power, 2-channel data-out: 1A/1B → 1A/1B 2A/2B → 2A/2B LineOut1 → 3A/3B LineOut2 → 4A/4B Line out configuration determined by LOC register	0
01	2 (half-bridge), 1 (full-bridge) on-board power: 1A → 1A      Binary 0° 2A → 1B      Binary 90° 3A/3B → 2A/2B    Binary 45° 1A/B → 3A/B      Binary 0° 2A/B → 4A/B      Binary 90°	0
10	2-channel (full-bridge) power, 1-channel DDX: 1A/1B → 1A/1B 2A/2B → 2A/2B 3A/3B → 3A/3B EAPDEXT and TWARDNEXT Active	0
11	1-channel mono-parallel: 3A → 1A/1B    w/ C3BO 45° 3B → 2A/2B    w/ C3BO 45° 1A/1B → 3A/3B 2A/2B → 4A/4B	1

*Note:* To the left of the arrow is the processing channel. When using channel output mapping, any of the three processing channel outputs can be used for any of the three inputs.

Figure 12. OCFG = 00 (default value)

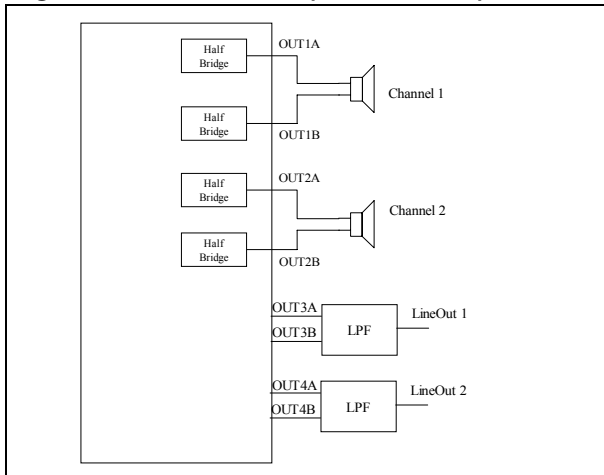

Figure 13. OCFG = 01

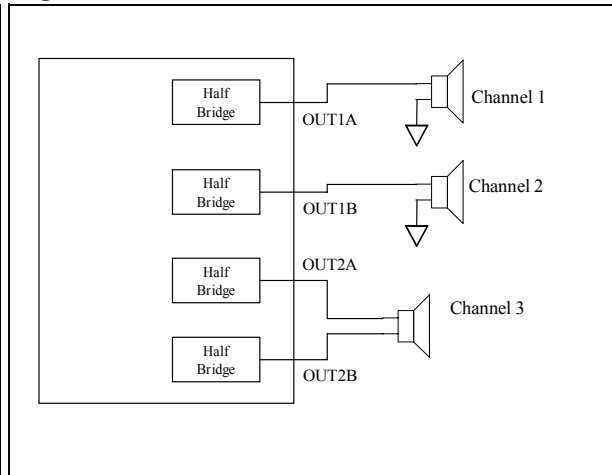

Figure 14. OCFG = 10

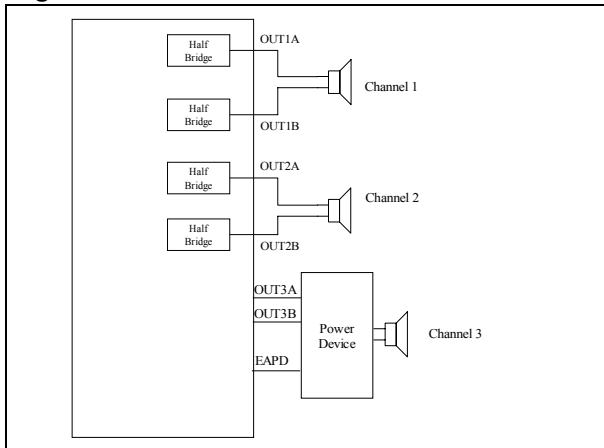
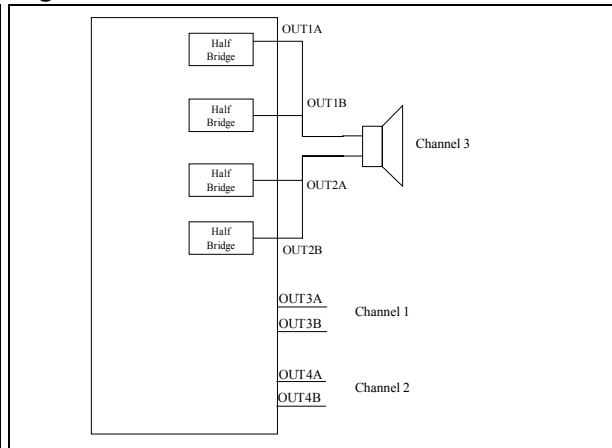
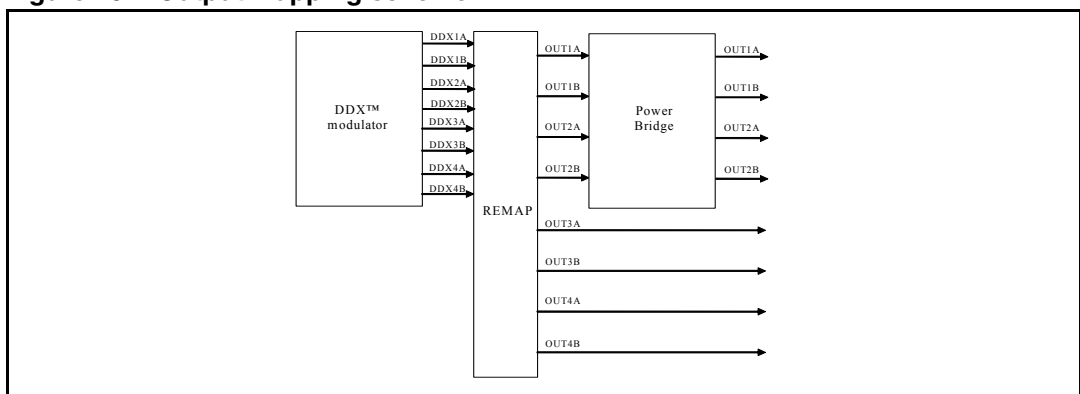

Figure 15. OCFG = 11



STA335BWQS can be configured to support different output configurations. For each PWM output channel a PWM slot is defined. The PWM slot always has a time duration of  $1 / (8 * f_s)$  seconds and defines the maximum extension for PWM rising and falling edges, that is, rising edge as far as the falling edge cannot range outside PWM slot boundaries.

Figure 16. Output mapping scheme.



For each configuration the PWM from the digital driver is mapped in a different way to the power stage:

**2.0 channels, two full bridges (OCFG = 00)**

- DDX1A : OUT1A
- DDX1B : OUT1B
- DDX2A : OUT2A
- DDX2B : OUT2B
- DDX3A : OUT3A
- DDX3B : OUT3B
- DDX4A : OUT4A
- DDX4B : OUT4B
- DDX1A/1B configured as ternary
- DDX2A/2B configured as ternary
- DDX3A/3B configured as line-out ternary
- DDX4A/4B configured as line-out ternary.

On channel 3 line out (LOC bits = 00) the same data as channel 1 processing are sent. On channel 4 line out (LOC bits = 00) the same data as channel 2 processing are sent. In this configuration, no volume control or EQ have effect on channel 3 and 4.

*Figure 17* shows the PWM slot phases for this configuration.

**Figure 17. 2.0 channels (OCFG = 00) PWM slots.**

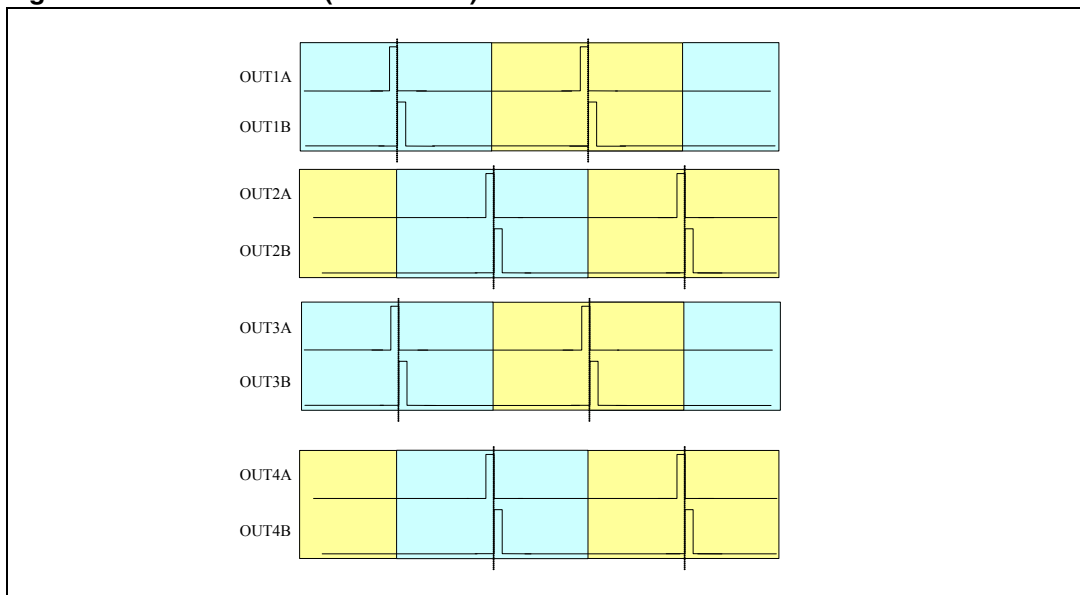



**2.1 channels, two half bridges + one full bridge (OCFG = 01)**

- DDX1A : OUT1A
- DDX2A : OUT1B
- DDX3A : OUT2A
- DDX3B : OUT2B
- DDX1A : OUT3A
- DDX1B : OUT3B
- DDX2A : OUT4A
- DDX2B : OUT4B
- DDX1A/1B configured as binary
- DDX2A/2B configured as binary
- DDX3A/3B configured as binary
- DDX4A/4B not used.

In this configuration, channel 3 has full control (for example, on volume, EQ). On OUT3/OUT4 channels the channel 1 and channel 2 PWM are replicated.

*Figure 18* shows the PWM slot phases for this configuration.

**Figure 18. 2.1 channels (OCFG = 01) PWM slots.**

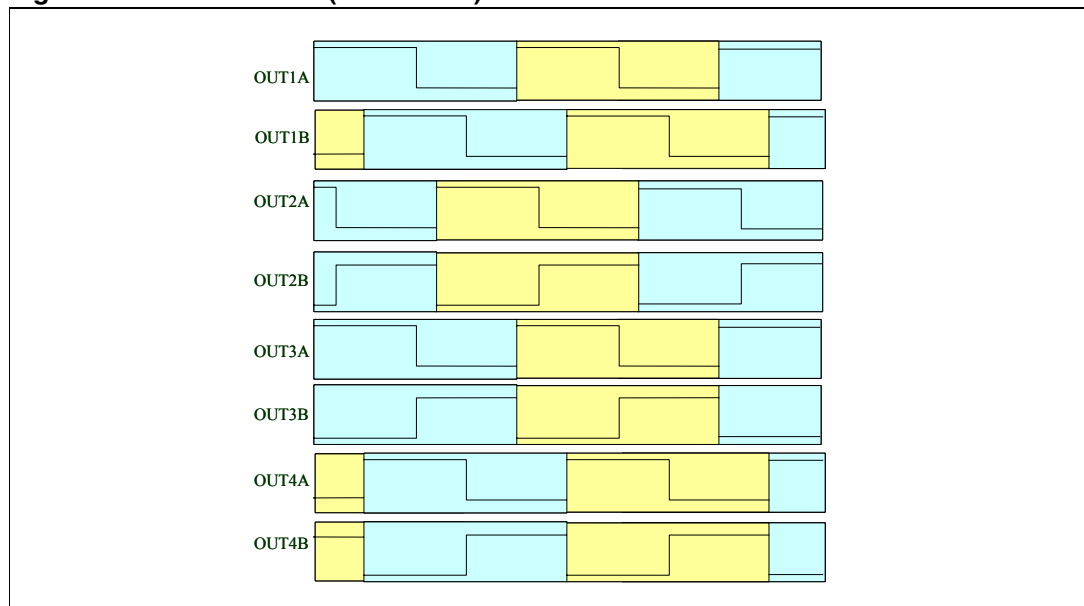

**2.1 channels, two full bridge + one external full bridge (OCFG = 10)**

- DDX1A : OUT1A
- DDX1B : OUT1B
- DDX2A : OUT2A
- DDX2B : OUT2B
- DDX3A : OUT3A
- DDX3B : OUT3B
- EAPD : OUT4A
- TWARN : OUT4B
- DDX1A/1B configured as ternary
- DDX2A/2B configured as ternary
- DDX3A/3B configured as ternary
- DDX4A/4B not used.

In this configuration, channel 3 has full control (for example, on volume, EQ). On OUT4 channel the external bridge control signals are muxed.

Figure 19 shows the PWM slot phases for this configuration.

**Figure 19. 2.1 channels (OCFG = 10) PWM slots.**

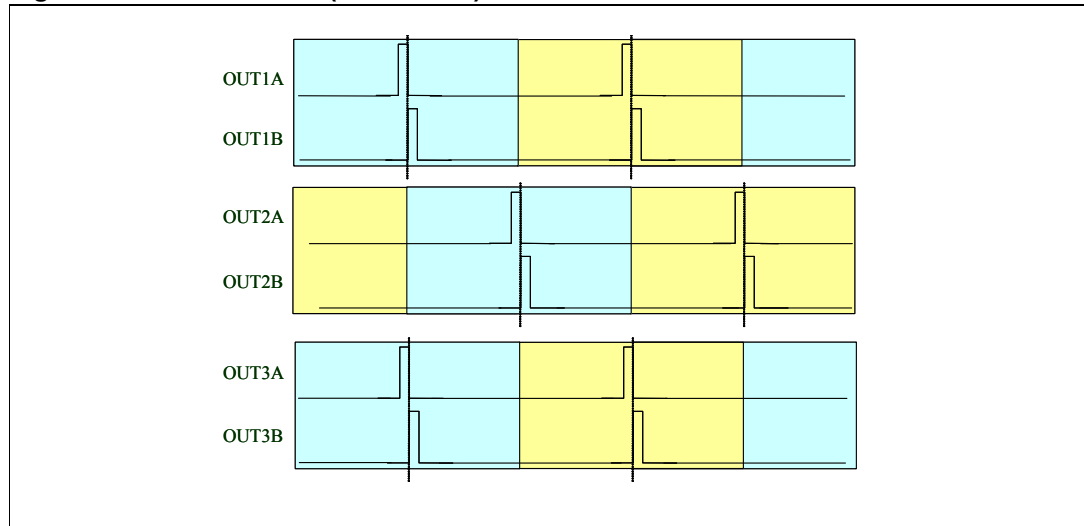

**7.6.2 Invalid input detect mute enable**

**Table 46. IDE**

Bit	R/W	RST	Name	Description
2	RW	1	IDE	Setting of 1 enables the automatic invalid input detect mute

Setting the IDE bit enables this function, which looks at the input I<sup>2</sup>S data and will automatically mute if the signals are perceived as invalid.

### 7.6.3 Binary output mode clock loss detection

Table 47. BCLE

Bit	R/W	RST	Name	Description
3	RW	1	BCLE	Binary output mode clock loss detection enable

Detects loss of input MCLK in binary mode and will output 50% duty cycle.

### 7.6.4 LRCK double trigger protection

Table 48. LDTE

Bit	R/W	RST	Name	Description
4	RW	1	LDTE	LRCLK double trigger protection enable

Actively prevents double trigger of LRCLK.

### 7.6.5 Auto EAPD on clock loss

Table 49. ECLE

Bit	R/W	RST	Name	Description
5	RW	0	ECLE	Auto EAPD on clock loss

When active, issues a power device power down signal (EAPD) on clock loss detection.

### 7.6.6 IC power down

Table 50. PWDN

Bit	R/W	RST	Name	Description
7	RW	1	PWDN	0: IC power down low-power condition 1: IC normal operation

The PWDN register is used to place the IC in a low-power state. When PWDN is written as 0, the output begins a soft-mute. After the mute condition is reached, EAPD is asserted to power down the power-stage, then the master clock to all internal hardware except the I<sup>2</sup>C block is gated. This places the IC in a very low power consumption state.

### 7.6.7 External amplifier power down

Table 51. EAPD

Bit	R/W	RST	Name	Description
7	RW	0	EAPD	0: External power stage power down active 1: Normal operation

The EAPD register directly disables/enables the internal power circuitry.

When EAPD = 0, the internal power section is placed on a low-power state (disabled). This register also controls the DDX4B/EAPD output pin when OCFG = 10.

## 7.7 Volume control registers (addr 0x06 to 0x0A)

### 7.7.1 Mute/line output configuration register

D7	D6	D5	D4	D3	D2	D1	D0
LOC1	LOC0	Reserved	Reserved	C3M	C2M	C1M	MMUTE
0	0	0	0	0	0	0	0

**Table 52. LOC description**

LOC[1:0]	Line output configuration
00	Line output fixed - no volume, no EQ
01	Line output variable - CH3 volume effects line output, no EQ
10	Line output variable with EQ - CH3 volume effects line output

Line output is only active when OCFG = 00. In this case LOC determines the line output configuration. The source of the line output is always the channel 1 and 2 inputs.

### 7.7.2 Master volume register

D7	D6	D5	D4	D3	D2	D1	D0
MV7	MV6	MV5	MV4	MV3	MV2	MV1	MV0
1	1	1	1	1	1	1	1

### 7.7.3 Channel 1 volume

D7	D6	D5	D4	D3	D2	D1	D0
C1V7	C1V6	C1V5	C1V4	C1V3	C1V2	C1V1	C1V0
0	1	1	0	0	0	0	0

### 7.7.4 Channel 2 volume

D7	D6	D5	D4	D3	D2	D1	D0
C2V7	C2V6	C2V5	C2V4	C2V3	C2V2	C2V1	C2V0
0	1	1	0	0	0	0	0

### 7.7.5 Channel 3 / line output volume

D7	D6	D5	D4	D3	D2	D1	D0
C3V7	C3V6	C3V5	C3V4	C3V3	C3V2	C3V1	C3V0
0	1	1	0	0	0	0	0

The volume structure of the STA335BWQS consists of separate volume registers for each channel and a master volume register to provide an offset to each channel volume setting. The individual channel volumes are adjustable in 0.5 dB steps from +48 dB to -80 dB.

As an example if C3V = 0x00 (+48 dB) and MV = 0x18 (-12 dB) then the total gain for channel 3 = +36 dB.

The master mute, when set to 1, mutes all channels at once, whereas the individual channel mutes (CnM) mutes only that channel. Both the master mute and the channel mutes provide a “soft mute” with the volume ramping down to mute in 4096 samples from the maximum volume setting at the internal processing rate (~96 kHz).

A “hard mute” can be obtained by programming a value of 0xFF (255) to any channel volume register or the master volume register. When volume offsets are provided via the master volume register any channel that whose total volume is less than -80 dB is muted.

All changes in volume take place at zero-crossings when ZCE = 1 ([Configuration register F \(addr 0x05\)](#)) on a per channel basis as this creates the smoothest possible volume transitions. When ZCE=0, volume updates occur immediately.

**Table 53. Master volume offset as a function of MV[7:0]**

MV[7:0]	Volume offset from channel value
00000000 (0x00)	0 dB
00000001 (0x01)	-0.5 dB
00000010 (0x02)	-1 dB
...	...
01001100 (0x4C)	-38 dB
...	...
11111110 (0xFE)	-127.5 dB
11111111 (0xFF)	Hard master mute

**Table 54. Channel volume as a function of CnV[7:0]**

CnV[7:0]	Volume
00000000 (0x00)	+48 dB
00000001 (0x01)	+47.5 dB
00000010 (0x02)	+47 dB
...	...
01011111 (0x5F)	+0.5 dB
01100000 (0x60)	0 dB
01100001 (0x61)	-0.5 dB

**Table 54. Channel volume as a function of CnV[7:0] (continued)**

CnV[7:0]	Volume
...	...
11010111 (0xD7)	-59.5 dB
11011000 (0xD8)	-60 dB
11011001 (0xD9)	-61 dB
11011010 (0xDA)	-62 dB
...	...
11101100 (0xEC)	-80 dB
11101101 (0xED)	Hard channel mute
...	...
11111111 (0xFF)	Hard channel mute

## 7.8 Auto mode registers (addr 0x0B and 0x0C)

### 7.8.1 AutoModes™ register 1 (0x0B)

D7	D6	D5	D4	D3	D2	D1	D0
Reserved	Reserved	AMGC1	AMGC2	Reserved	Reserved	Reserved	Reserved
0	0	0	0	0	0	0	0

**Table 55. AutoModes™ gain compression/limiters selection**

AMGC[1:0]	Mode
00	User programmable GC
01	AC no clipping 2.1
10	AC limited clipping (10%) 2.1
11	DRC nighttime listening mode 2.1

### 7.8.2 AutoModes™ register 2 (0x0C)

D7	D6	D5	D4	D3	D2	D1	D0
XO3	XO2	XO1	XO0	AMAM2	AMAM1	AMAM0	AMAME
0	0	0	0	0	0	0	0

### 7.8.3 AM interference frequency switching

**Table 56. AM enable**

Bit	R/W	RST	Name	Description
0	RW	0	AMAME	AutoModes™ AM enable 0: switching frequency determined by PWMS setting 1: switching frequency determined by AMAM settings

**Table 57. AutoModes™ AM switching frequency selection**

AMAM[2:0]	48 kHz/96 kHz input fs	44.1 kHz/88.2 kHz input fs
000	0.535 MHz - 0.720 MHz	0.535 MHz - 0.670 MHz
001	0.721 MHz - 0.900 MHz	0.671 MHz - 0.800 MHz
010	0.901 MHz - 1.100 MHz	0.801 MHz - 1.000 MHz
011	1.101 MHz - 1.300 MHz	1.001 MHz - 1.180 MHz
100	1.301 MHz - 1.480 MHz	1.181 MHz - 1.340 MHz
101	1.481 MHz - 1.600 MHz	1.341 MHz - 1.500 MHz
110	1.601 MHz - 1.700 MHz	1.501 MHz - 1.700 MHz

### 7.8.4 Bass management crossover

Bit	R/W	RST	Name	Description
4	RW	0	XO0	Selects the bass-management crossover frequency. A 1st-order high-pass filtering (channels 1 and 2) or a 2nd-order low-pass filtering (channel 3) at the selected frequency is performed.
5	RW	0	XO1	
6	RW	0	XO2	
7	RW	0	XO3	

**Table 58. Bass management crossover frequency**

XO[3:0]	Crossover frequency
0000	User-Defined
0001	80 Hz
0010	100 Hz
0011	120 Hz
0100	140 Hz
0101	160 Hz
0110	180 Hz
0111	200 Hz
1000	220 Hz
1001	240 Hz
1010	260 Hz

**Table 58. Bass management crossover frequency (continued)**

XO[3:0]	Crossover frequency
1011	280 Hz
1100	300 Hz
1101	320 Hz
1110	340 Hz
1111	360 Hz

## 7.9 Channel configuration registers (addr 0x0E to 0x10)

D7	D6	D5	D4	D3	D2	D1	D0
C1OM1	C1OM0	C1LS1	C1LS0	C1BO	C1VPB	C1EQBP	C1TCB
0	0	0	0	0	0	0	0

D7	D6	D5	D4	D3	D2	D1	D0
C2OM1	C2OM0	C2LS1	C2LS0	C2BO	C2VPB	C2EQBP	C2TCB
0	1	0	0	0	0	0	0

D7	D6	D5	D4	D3	D2	D1	D0
C3OM1	C3OM0	C3LS1	C3LS0	C3BO	C3VPB	Reserved	Reserved
1	0	0	0	0	0	0	0

### 7.9.1 Tone control bypass

Tone control (bass/treble) can be bypassed on a per channel basis for channels 1 and 2.

CnTCB:

0: Perform tone control on channel n - normal operation

1: Bypass tone control on channel n

### 7.9.2 EQ bypass

EQ control can be bypassed on a per channel basis for channels 1 and 2. If EQ control is bypassed on a given channel the prescale and all filters (high-pass, biquads, de-emphasis, bass, treble in any combination) are bypassed for that channel.

CnEQBP:

0: Perform EQ on channel n - normal operation

1: Bypass EQ on channel n

### 7.9.3 Volume bypass

Each channel contains an individual channel volume bypass. If a particular channel has volume bypassed via the CnVBP = 1 register then only the channel volume setting for that particular channel affects the volume setting, the master volume setting will not affect that channel.



### 7.9.4 Binary output enable registers

Each individual channel output can be set to output a binary PWM stream. In this mode output A of a channel is considered the positive output and output B is negative inverse.

CnBO:

0: DDX 3-state output - normal operation

1: Binary output

### 7.9.5 Limiter select

Limiter selection can be made on a per-channel basis according to the channel limiter select bits.

**Table 59. Channel limiter mapping as a function of CnLS bits**

CnLS[1,0]	Channel limiter mapping
00	Channel has limiting disabled
01	Channel is mapped to limiter #1
10	Channel is mapped to limiter #2

### 7.9.6 Output mapping

Output mapping can be performed on a per channel basis according to the CnOM channel output mapping bits. Each input into the output configuration engine can receive data from any of the three processing channel outputs.

**Table 60. Channel output mapping as a function of CnOM bits**

CnOM[1,0]	Channel n output source from
00	Channel 1
01	Channel 2
10	Channel 3

## 7.10 Tone control register (addr 0x11)

### 7.10.1 Tone control

D7	D6	D5	D4	D3	D2	D1	D0
TTC3	TTC2	TTC1	TTC0	BTC3	BTC2	BTC1	BTC0
0	1	1	1	0	1	1	1

**Table 61. Tone control boost/cut as a function of BTC and TTC bits**

BTC[3:0] / TTC[3:0]	Boost / Cut
0000	-12 dB
0001	-12 dB
...	...
0111	-4 dB
0110	-2 dB
0111	0 dB
1000	+2 dB
1001	+4 dB
...	...
1101	+12 dB
1110	+12 dB
1111	+12 dB

## 7.11 Dynamics control registers (addr 0x12 to 0x15)

### 7.11.1 Limiter 1 attack/release rate

D7	D6	D5	D4	D3	D2	D1	D0
L1A3	L1A2	L1A1	L1A0	L1R3	L1R2	L1R1	L1R0
0	1	1	0	1	0	1	0

### 7.11.2 Limiter 1 attack/release threshold

D7	D6	D5	D4	D3	D2	D1	D0
L1AT3	L1AT2	L1AT1	L1AT0	L1RT3	L1RT2	L1RT1	L1RT0
0	1	1	0	1	0	0	1

### 7.11.3 Limiter 2 attack/release rate

D7	D6	D5	D4	D3	D2	D1	D0
L2A3	L2A2	L2A1	L2A0	L2R3	L2R2	L2R1	L2R0
0	1	1	0	1	0	1	0

### 7.11.4 Limiter 2 attack/release threshold

D7	D6	D5	D4	D3	D2	D1	D0
L2AT3	L2AT2	L2AT1	L2AT0	L2RT3	L2RT2	L2RT1	L2RT0
0	1	1	0	1	0	0	1

The STA335BWQS includes two independent limiter blocks. The purpose of the limiters is to automatically reduce the dynamic range of a recording to prevent the outputs from clipping in anti-clipping mode or to actively reduce the dynamic range for a better listening environment such as a night-time listening mode which is often needed for DVDs. The two modes are selected via the DRC bit in *Configuration register F (addr 0x05)*, bit 0. Each channel can be mapped to either limiter or not mapped, meaning that channel will clip when 0 dBFS is exceeded. Each limiter looks at the present value of each channel that is mapped to it, selects the maximum absolute value of all these channels, performs the limiting algorithm on that value, and then if needed adjusts the gain of the mapped channels in unison.

The limiter attack thresholds are determined by the LnAT registers. It is recommended in anti-clipping mode to set this to 0 dBFS, which corresponds to the maximum unclipped output power of a DDX amplifier. Since gain can be added digitally within STA335BWQS it is possible to exceed 0 dBFS or any other LnAT setting, when this occurs, the limiter, when active, automatically starts reducing the gain. The rate at which the gain is reduced when the attack threshold is exceeded is dependent upon the attack rate register setting for that limiter. The gain reduction occurs on a peak-detect algorithm.

The release of limiter, when the gain is again increased, is dependent on a RMS-detect algorithm. The output of the volume/limiter block is passed through a RMS filter. The output of this filter is compared to the release threshold, determined by the Release Threshold register. When the RMS filter output falls below the release threshold, the gain is again increased at a rate dependent upon the Release Rate register. The gain can never be increased past it's set value and therefore the release only occurs if the limiter has already reduced the gain. The release threshold value can be used to set what is effectively a minimum dynamic range, this is helpful as over-limiting can reduce the dynamic range to virtually zero and cause program material to sound "lifeless".

In AC mode, the attack and release thresholds are set relative to full-scale. In DRC mode, the attack threshold is set relative to the maximum volume setting of the channels mapped to that limiter and the release threshold is set relative to the maximum volume setting plus the attack threshold.

**Figure 20. Basic limiter and volume flow diagram**

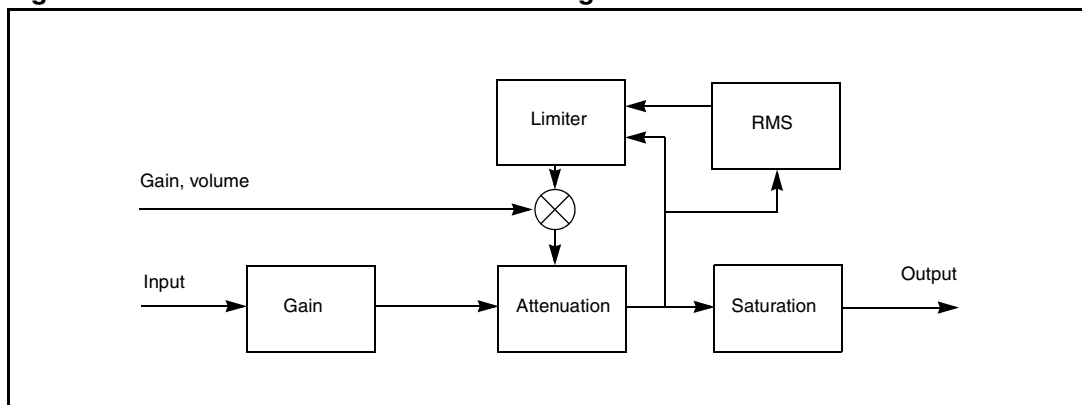

**Table 62. Attack rate**

<b>LnA[3:0]</b>	<b>Attack rate (dB/ms)</b>
0000	3.1584 (fast)
0001	2.7072
0010	2.2560
0011	1.8048
0100	1.3536
0101	0.9024
0110	0.4512
0111	0.2256
1000	0.1504
1001	0.1123
1010	0.0902
1011	0.0752
1100	0.0645
1101	0.0564
1110	0.0501
1111	0.0451 (slow)

**Table 63. Release rate**

<b>LnR[3:0]</b>	<b>Release rate (dB/s)</b>
0000	3.904 (fast)
0001	3.859
0010	3.859
0011	3.849
0100	3.793
0101	3.750
0110	3.682
0111	3.549
1000	3.483
1001	3.448
1010	3.357
1011	3.284
1100	3.082
1101	2.957
1110	2.864
1111	2.864 (slow)

**Table 64. LnAT bits, anti-clipping**

LnAT[3:0]	Anti-clipping (AC) (dB relative to FS)
0000	-12
0001	-10
0010	-8
0011	-6
0100	-4
0101	-2
0110	0
0111	+2
1000	+3
1001	+4
1010	+5
1011	+6
1100	+7
1101	+8
1110	+9
1111	+10

**Table 65. LnRT bits, anti-clipping**

LnRT[3:0]	Anti-clipping (AC) (dB relative to FS)
0000	$-\infty$
0001	-29 dB
0010	-20 dB
0011	-16 dB
0100	-14 dB
0101	-12 dB
0110	-10 dB
0111	-8 dB
1000	-7 dB
1001	-6 dB
1010	-5 dB
1011	-4 dB
1100	-3 dB
1101	-2 dB

**Table 65. LnRT bits, anti-clipping (continued)**

LnRT[3:0]	Anti-clipping (AC) (dB relative to FS)
1110	-1 dB
1111	-0 dB

**Table 66. LnAT bits, dynamic range compression**

LnAT[3:0]	Dynamic range compression (DRC) (dB relative to volume)
0000	-31
0001	-29
0010	-27
0011	-25
0100	-23
0101	-21
0110	-19
0111	-17
1000	-16
1001	-15
1010	-14
1011	-13
1100	-12
1101	-10
1110	-7
1111	-4

**Table 67. LnRT bits, dynamic range compression**

LnRT[3:0]	Dynamic range compression (DRC) (dB relative to volume + LnAT)
0000	$-\infty$
0001	-38 dB
0010	-36 dB
0011	-33 dB
0100	-31 dB
0101	-30 dB
0110	-28 dB
0111	-26 dB
1000	-24 dB
1001	-22 dB

**Table 67. LnRT bits, dynamic range compression (continued)**

LnRT[3:0]	Dynamic range compression (DRC) (dB relative to volume + LnAT)
1010	-20 dB
1011	-18 dB
1100	-15 dB
1101	-12 dB
1110	-9 dB
1111	-6 dB

## 7.12 User-defined coefficient control registers (addr 0x16 to 0x26)

### 7.12.1 Coefficient address register

D7	D6	D5	D4	D3	D2	D1	D0
Reserved	Reserved	CFA5	CFA4	CFA3	CFA2	CFA1	CFA0
0	0	0	0	0	0	0	0

### 7.12.2 Coefficient b1 data register bits 23:16

D7	D6	D5	D4	D3	D2	D1	D0
C1B23	C1B22	C1B21	C1B20	C1B19	C1B18	C1B17	C1B16
0	0	0	0	0	0	0	0

### 7.12.3 Coefficient b1 data register bits 15:8

D7	D6	D5	D4	D3	D2	D1	D0
C1B15	C1B14	C1B13	C1B12	C1B11	C1B10	C1B9	C1B8
0	0	0	0	0	0	0	0

### 7.12.4 Coefficient b1 data register bits 7:0

D7	D6	D5	D4	D3	D2	D1	D0
C1B7	C1B6	C1B5	C1B4	C1B3	C1B2	C1B1	C1B0
0	0	0	0	0	0	0	0

### 7.12.5 Coefficient b2 data register bits 23:16

D7	D6	D5	D4	D3	D2	D1	D0
C2B23	C2B22	C2B21	C2B20	C2B19	C2B18	C2B17	C2B16
0	0	0	0	0	0	0	0

**7.12.6 Coefficient b2 data register bits 15:8**

D7	D6	D5	D4	D3	D2	D1	D0
C2B15	C2B14	C2B13	C2B12	C2B11	C2B10	C2B9	C2B8
0	0	0	0	0	0	0	0

**7.12.7 Coefficient b2 data register bits 7:0**

D7	D6	D5	D4	D3	D2	D1	D0
C2B7	C2B6	C2B5	C2B4	C2B3	C2B2	C2B1	C2B0
0	0	0	0	0	0	0	0

**7.12.8 Coefficient a1 data register bits 23:16**

D7	D6	D5	D4	D3	D2	D1	D0
C3B23	C3B22	C3B21	C3B20	C3B19	C3B18	C3B17	C3B16
0	0	0	0	0	0	0	0

**7.12.9 Coefficient a1 data register bits 15:8**

D7	D6	D5	D4	D3	D2	D1	D0
C3B15	C3B14	C3B13	C3B12	C3B11	C3B10	C3B9	C3B8
0	0	0	0	0	0	0	0

**7.12.10 Coefficient a1 data register bits 7:0**

D7	D6	D5	D4	D3	D2	D1	D0
C3B7	C3B6	C3B5	C3B4	C3B3	C3B2	C3B1	C3B0
0	0	0	0	0	0	0	0

**7.12.11 Coefficient a2 data register bits 23:16**

D7	D6	D5	D4	D3	D2	D1	D0
C4B23	C4B22	C4B21	C4B20	C4B19	C4B18	C4B17	C4B16
0	0	0	0	0	0	0	0

**7.12.12 Coefficient a2 data register bits 15:8**

D7	D6	D5	D4	D3	D2	D1	D0
C4B15	C4B14	C4B13	C4B12	C4B11	C4B10	C4B9	C4B8
0	0	0	0	0	0	0	0



**7.12.13 Coefficient a2 data register bits 7:0**

D7	D6	D5	D4	D3	D2	D1	D0
C4B7	C4B6	C4B5	C4B4	C4B3	C4B2	C4B1	C4B0
0	0	0	0	0	0	0	0

**7.12.14 Coefficient b0 data register bits 23:16**

D7	D6	D5	D4	D3	D2	D1	D0
C5B23	C5B22	C5B21	C5B20	C5B19	C5B18	C5B17	C5B16
0	0	0	0	0	0	0	0

**7.12.15 Coefficient b0 data register bits 15:8**

D7	D6	D5	D4	D3	D2	D1	D0
C5B15	C5B14	C5B13	C5B12	C5B11	C5B10	C5B9	C5B8
0	0	0	0	0	0	0	0

**7.12.16 Coefficient b0 data register bits 7:0**

D7	D6	D5	D4	D3	D2	D1	D0
C5B7	C5B6	C5B5	C5B4	C5B3	C5B2	C5B1	C5B0
0	0	0	0	0	0	0	0

**7.12.17 Coefficient write/read control register**

D7	D6	D5	D4	D3	D2	D1	D0
Reserved	Reserved	Reserved	Reserved	RA	R1	WA	W1
0	0	0	0	0	0	0	0

Coefficients for user-defined EQ, Mixing, Scaling, and Bass Management are handled internally in the STA335BWQS via RAM. Access to this RAM is available to the user via an I<sup>2</sup>C register interface. A collection of I<sup>2</sup>C registers are dedicated to this function. One contains a coefficient base address, five sets of three store the values of the 24-bit coefficients to be written or that were read, and one contains bits used to control the write/read of the coefficient(s) to/from RAM.

*Note: The read and write operation on RAM coefficients works only if LRCKI (pin 29) is switching.*

**Reading a coefficient from RAM**

1. Write 6-bits of address to I<sup>2</sup>C register 0x16.
2. Write 1 to R1 bit in I<sup>2</sup>C address 0x26.
3. Read top 8-bits of coefficient in I<sup>2</sup>C address 0x17.
4. Read middle 8-bits of coefficient in I<sup>2</sup>C address 0x18.
5. Read bottom 8-bits of coefficient in I<sup>2</sup>C address 0x19.

**Reading a set of coefficients from RAM**

1. Write 6-bits of address to I<sup>2</sup>C register 0x16.
2. Write 1 to RA bit in I<sup>2</sup>C address 0x26.
3. Read top 8-bits of coefficient in I<sup>2</sup>C address 0x17.
4. Read middle 8-bits of coefficient in I<sup>2</sup>C address 0x18.
5. Read bottom 8-bits of coefficient in I<sup>2</sup>C address 0x19.
6. Read top 8-bits of coefficient b2 in I<sup>2</sup>C address 0x1A.
7. Read middle 8-bits of coefficient b2 in I<sup>2</sup>C address 0x1B.
8. Read bottom 8-bits of coefficient b2 in I<sup>2</sup>C address 0x1C.
9. Read top 8-bits of coefficient a1 in I<sup>2</sup>C address 0x1D.
10. Read middle 8-bits of coefficient a1 in I<sup>2</sup>C address 0x1E.
11. Read bottom 8-bits of coefficient a1 in I<sup>2</sup>C address 0x1F.
12. Read top 8-bits of coefficient a2 in I<sup>2</sup>C address 0x20.
13. Read middle 8-bits of coefficient a2 in I<sup>2</sup>C address 0x21.
14. Read bottom 8-bits of coefficient a2 in I<sup>2</sup>C address 0x22.
15. Read top 8-bits of coefficient b0 in I<sup>2</sup>C address 0x23.
16. Read middle 8-bits of coefficient b0 in I<sup>2</sup>C address 0x24.
17. Read bottom 8-bits of coefficient b0 in I<sup>2</sup>C address 0x25.

**Writing a single coefficient to RAM**

1. Write 6-bits of address to I<sup>2</sup>C register 0x16.
2. Write top 8-bits of coefficient in I<sup>2</sup>C address 0x17.
3. Write middle 8-bits of coefficient in I<sup>2</sup>C address 0x18.
4. Write bottom 8-bits of coefficient in I<sup>2</sup>C address 0x19.
5. Write 1 to W1 bit in I<sup>2</sup>C address 0x26.

### Writing a set of coefficients to RAM

1. Write 6-bits of starting address to I<sup>2</sup>C register 0x16.
2. Write top 8-bits of coefficient b1 in I<sup>2</sup>C address 0x17.
3. Write middle 8-bits of coefficient b1 in I<sup>2</sup>C address 0x18.
4. Write bottom 8-bits of coefficient b1 in I<sup>2</sup>C address 0x19.
5. Write top 8-bits of coefficient b2 in I<sup>2</sup>C address 0x1A.
6. Write middle 8-bits of coefficient b2 in I<sup>2</sup>C address 0x1B.
7. Write bottom 8-bits of coefficient b2 in I<sup>2</sup>C address 0x1C.
8. Write top 8-bits of coefficient a1 in I<sup>2</sup>C address 0x1D.
9. Write middle 8-bits of coefficient a1 in I<sup>2</sup>C address 0x1E.
10. Write bottom 8-bits of coefficient a1 in I<sup>2</sup>C address 0x1F.
11. Write top 8-bits of coefficient a2 in I<sup>2</sup>C address 0x20.
12. Write middle 8-bits of coefficient a2 in I<sup>2</sup>C address 0x21.
13. Write bottom 8-bits of coefficient a2 in I<sup>2</sup>C address 0x22.
14. Write top 8-bits of coefficient b0 in I<sup>2</sup>C address 0x23.
15. Write middle 8-bits of coefficient b0 in I<sup>2</sup>C address 0x24.
16. Write bottom 8-bits of coefficient b0 in I<sup>2</sup>C address 0x25.
17. Write 1 to WA bit in I<sup>2</sup>C address 0x26.

The mechanism for writing a set of coefficients to RAM provides a method of updating the five coefficients corresponding to a given biquad (filter) simultaneously to avoid possible unpleasant acoustic side-effects. When using this technique, the 6-bit address specifies the address of the biquad b1 coefficient (for example, 0, 5, 10, 20, 35 decimal), and the STA335BWQS generates the RAM addresses as offsets from this base value to write the complete set of coefficient data.

### 7.12.18 User-defined EQ

The STA335BWQS provides the ability to specify four EQ filters (biquads) per each of the two input channels. The biquads use the following equation:

$$Y[n] = 2(b_0/2)X[n] + 2(b_1/2)X[n-1] + b_2X[n-2] - 2(a_1/2)Y[n-1] - a_2Y[n-2]$$

$$= b_0X[n] + b_1X[n-1] + b_2X[n-2] - a_1Y[n-1] - a_2Y[n-2]$$

where Y[n] represents the output and X[n] represents the input. Multipliers are 24-bit signed fractional multipliers, with coefficient values in the range of 0x800000 (-1) to 0x7FFFFFFF (0.9999998808).

Coefficients stored in the user defined coefficient RAM are referenced in the following manner:

$$CnHm0 = b_1/2$$

$$CnHm1 = b_2$$

$$CnHm2 = -a_1/2$$

$$CnHm3 = -a_2$$

$$CnHm4 = b_0/2$$

where n represents the channel and the m the biquad number. For example C2H41 is the b<sub>2</sub> coefficient in the fourth biquad for channel 2.

Additionally, the STA335BWQS allows specification of a high-pass filter (processing channels 1 and 2) and a low-pass filter (processing channel 3) to be used for bass-management crossover when the XO setting is 000 (user-defined). Both of these filters, when defined by the user (rather than using the preset crossover filters), are second-order filters that use the biquad equation given above. They are loaded into the C12H0-4 and C3Hm0-4 areas of RAM noted in [Table 68](#).

By default, all user-defined filters are pass-through where all coefficients are set to 0, except the  $b_0/2$  coefficient which is set to 0x400000 (representing 0.5)

### 7.12.19 Pre-scale

The STA335BWQS provides a multiplication for each input channel for the purpose of scaling the input prior to EQ. This pre-EQ scaling is accomplished by using a 24-bit signed fractional multiplier, with 0x800000 = -1 and 0x7FFFFFFF = 0.9999998808. The scale factor for this multiply is loaded into RAM using the same I<sup>2</sup>C registers as the biquad coefficients and the bass-management. All channels can use the channel 1 pre-scale factor by setting the Biquad link bit. By default, all pre-scale factors are set to 0x7FFFFFFF.

### 7.12.20 Post-scale

The STA335BWQS provides one additional multiplication after the last interpolation stage and the distortion compensation on each channel. This post-scaling is accomplished by using a 24-bit signed fractional multiplier, with 0x800000 = -1 and 0x7FFFFFFF = 0.9999998808. The scale factor for this multiply is loaded into RAM using the same I<sup>2</sup>C registers as the biquad coefficients and the bass-management. This post-scale factor can be used in conjunction with an ADC equipped micro-controller to perform power-supply error correction. All channels can use the channel 1 post-scale factor by setting the post-scale link bit. By default, all post-scale factors are set to 0x7FFFFFFF. When Line output is being utilized, channel 3 post-scale will affect both channels 3 and 4.

### 7.12.21 Over-current post-scale

The STA335BWQS provides a simple mechanism for reacting to over-current detection in the power-block. When the OCWARN input is asserted, the over-current post-scale value is used in place of the normal post-scale value to provide output attenuation on all channels. The default setting provides 3 dB of output attenuation when OCWARN is asserted.

The amount of attenuation to be applied in this situation can be adjusted by modifying the Over-current post-scale value. As with the normal post-scale, this scaling value is a 24-bit signed fractional multiplier, with 0x800000 = -1 and 0x7FFFFFFF = 0.9999998808. By default, the over-current post-scale factor is set to 0x5A9DF7. Once the over-current attenuation is applied, it remains until the device is reset.

**Table 68. RAM block for biquads, mixing, scaling and bass setup**

Index (decimal)	Index (hex)		Coefficient	Default
0	0x00	Channel 1 - Biquad 1	C1H10(b1/2)	0x000000
1	0x01		C1H11(b2)	0x000000
2	0x02		C1H12(a1/2)	0x000000
3	0x03		C1H13(a2)	0x000000
4	0x04		C1H14(b0/2)	0x400000

Table 68. RAM block for biquads, mixing, scaling and bass setup (continued)

Index (decimal)	Index (hex)		Coefficient	Default
5	0x05	Channel 1 - Biquad 2	C1H20	0x000000
...	...	...	...	...
19	0x13	Channel 1 - Biquad 4	C1H44	0x400000
20	0x14	Channel 2 - Biquad 1	C2H10	0x000000
21	0x15		C2H11	0x000000
...	...	...	...	...
39	0x27	Channel 2 - Biquad 4	C2H44	0x400000
40	0x28	High-pass 2 <sup>nd</sup> order filter for XO=000	C12H0(b1/2)	0x000000
41	0x29		C12H1(b2)	0x000000
42	0x2A		C12H2(a1/2)	0x000000
43	0x2B		C12H3(a2)	0x000000
44	0x2C		C12H4(b0/2)	0x400000
45	0x2D	Low-pass 2 <sup>nd</sup> order filter for XO=000	C3H0(b1/2)	0x000000
46	0x2E		C3H1(b2)	0x000000
47	0x2F		C3H2(a1/2)	0x000000
48	0x30		C3H3(a2)	0x000000
49	0x31		C3H4(b0/2)	0x400000
50	0x32	Channel 1 - Pre-scale	C1PreS	0x7FFFFFFF
51	0x33	Channel 2 - Pre-scale	C2PreS	0x7FFFFFFF
52	0x34	Channel 1 - Post-scale	C1PstS	0x7FFFFFFF
53	0x35	Channel 2 - Post-scale	C2PstS	0x7FFFFFFF
54	0x36	Channel 3 - Post-scale	C3PstS	0x7FFFFFFF
55	0x37	TWARN/OC - Limit	TWOCL	0x5A9DF7
56	0x38	Channel 1 - Mix 1	C1MX1	0x7FFFFFFF
57	0x39	Channel 1 - Mix 2	C1MX2	0x000000
58	0x3A	Channel 2 - Mix 1	C2MX1	0x000000
59	0x3B	Channel 2 - Mix 2	C2MX2	0x7FFFFFFF
60	0x3C	Channel 3 - Mix 1	C3MX1	0x400000
61	0x3D	Channel 3 - Mix 2	C3MX2	0x400000
62	0x3E	Unused		
63	0x3F	Unused		

### 7.13 Variable max power correction registers (addr 0x27 to 0x28)

D7	D6	D5	D4	D3	D2	D1	D0
MPCC15	MPCC14	MPCC13	MPCC12	MPCC11	MPCC10	MPCC9	MPCC8
0	0	0	1	1	0	1	0

D7	D6	D5	D4	D3	D2	D1	D0
MPCC7	MPCC6	MPCC5	MPCC4	MPCC3	MPCC2	MPCC1	MPCC0
1	1	0	0	0	0	0	0

MPCC bits determine the 16 MSBs of the MPC compensation coefficient. This coefficient is used in place of the default coefficient when MPCV = 1.

### 7.14 Variable distortion compensation registers (addr 0x29 to 0x2A)

D7	D6	D5	D4	D3	D2	D1	D0
DCC15	DCC14	DCC13	DCC12	DCC11	DCC10	DCC9	DCC8
1	1	1	1	0	0	1	1

D7	D6	D5	D4	D3	D2	D1	D0
DCC7	DCC6	DCC5	DCC4	DCC3	DCC2	DCC1	DCC0
0	0	1	1	0	0	1	1

DCC bits determine the 16 MSBs of the distortion compensation coefficient. This coefficient is used in place of the default coefficient when DCCV = 1.

### 7.15 Fault detect recovery constant registers (addr 0x2B to 0x2C)

D7	D6	D5	D4	D3	D2	D1	D0
FDRC15	FDRC14	FDRC13	FDRC12	FDRC11	FDRC10	FDRC9	FDRC8
0	0	0	0	0	0	0	0

D7	D6	D5	D4	D3	D2	D1	D0
FDRC7	FDRC6	FDRC5	FDRC4	FDRC3	FDRC2	FDRC1	FDRC0
0	0	0	0	1	1	0	0

FDRC bits specify the 16-bit fault detect recovery time delay. When FAULT is asserted, the 3-STATE output is immediately asserted low and held low for the time period specified by this constant. A constant value of 0x0001 in this register is approximately 0.083 ms. The default value of 0x000C specifies approximately 0.1 ms.

## 7.16 Device status register (addr 0x2D)

D7	D6	D5	D4	D3	D2	D1	D0
PLLUL	FAULT	UVFAULT	OVFAULT	OCFAULT	OCWARN	TFAULT	TWARN

This read-only register provides fault and thermal-warning status information from the power control block. Logic value 1 for faults or warning means normal state. Logic 0 means a fault or warning detected on power bridge. The PLLUL = 1 means that the PLL is not locked.

- PLLUL: 0 = PLL locked, 1 = PLL not locked.
- FAULT: 0 = fault detected on power bridge, 1 = normal operation
- UVFAULT: 0 = VCCx internally detected < under-voltage threshold.
- OVFAULT: 0 = VCCx internally detected > over-voltage threshold.
- OCFAULT: 0 = over-current fault detected
- OCWARN: 0 = over-current warning.
- TFAULT: 0 = thermal fault. Junction temperature over limit detection.
- TWARN: 0 = thermal warning. The junction temperature is close to the fault condition.

# 8 Application

## 8.1 Application and power supplies

Figure 21 below shows the circuit diagram of a typical application for STA335BWQS. Particular care has to be given to the layout of the PCB, especially the power supplies. The 3.3-Ω resistors on the digital supplies (VDD\_DIG) have to be placed as close as possible to the device. This helps to prevent unwanted oscillation on the digital portion of the device due to inductive tracks of the PCB. This same rule also applies to all the decoupling capacitors in order to limit any kind of spikes on the supplies.

Figure 21. Application schematic

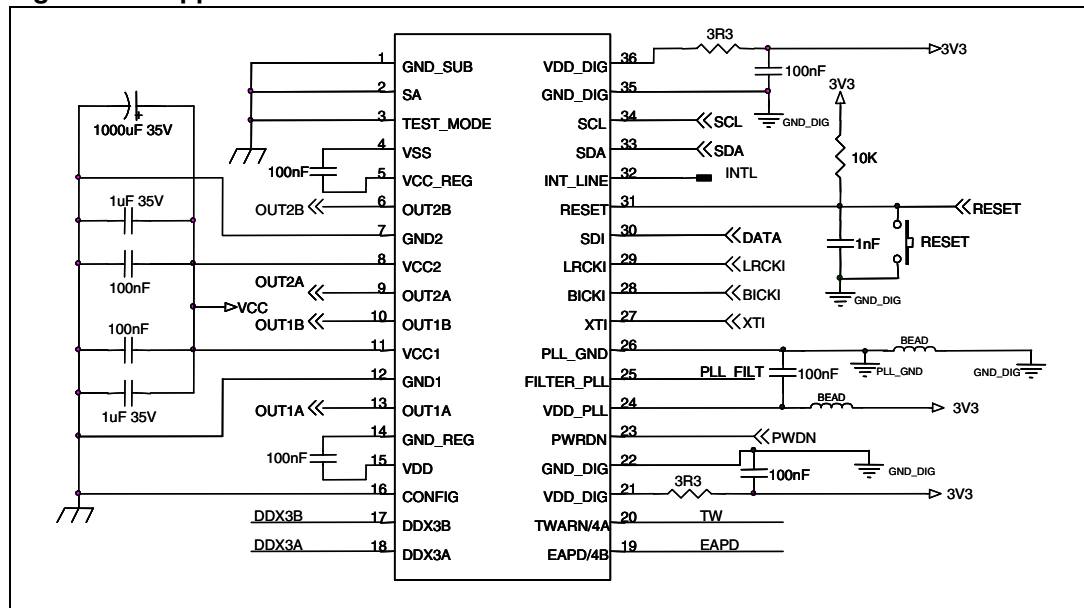

## 8.2 PLL filter

It is recommended to use the schematic and values in Figure 22 below for the PLL loop filter. In order to achieve the best performance from the device in general applications the filter ground (PLL\_GND) must be connected as close as possible to the device pin PLL\_GND. Concerning the component values, please take into account that the greater is the filter bandwidth, the less is the lock time but the higher is the PLL output jitter.

Figure 22. PLL application schematic

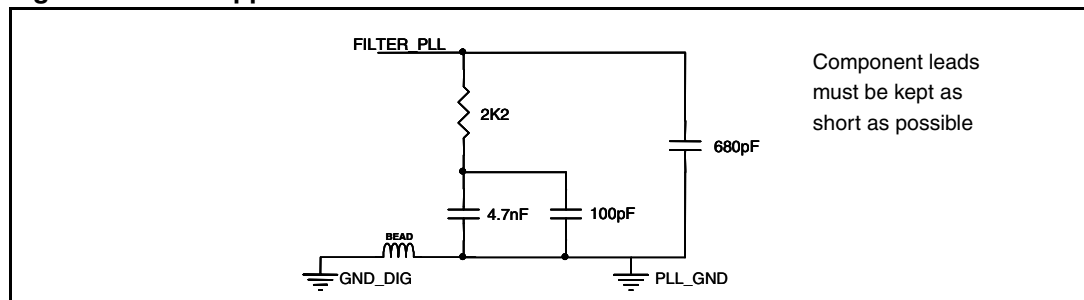



### 8.3 Typical output configuration

Figure 23 shows the typical output configuration used for BTL stereo mode. Please refer to the application note for other recommended output configuration schematics.

**Figure 23. Output configuration for stereo BTL mode**

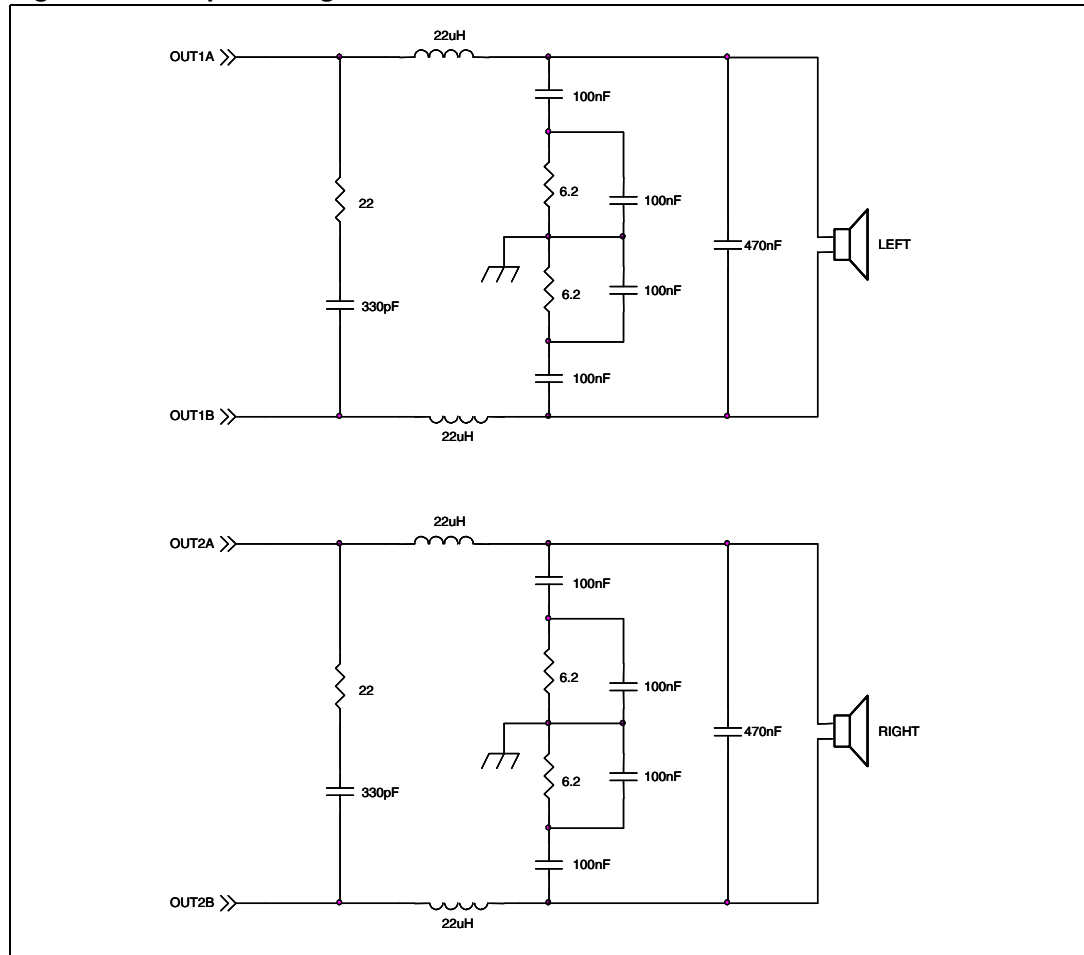

## 9 Package thermal characteristics

Using a double-layer PCB the thermal resistance (junction to ambient) with 2 copper ground areas of 3 cm x 3 cm and with 16 via holes (see [Figure 24](#)) is 24 °C/W in natural air convection.

The dissipated power within the device depends primarily on the supply voltage, load impedance and output modulation level.

The max estimated dissipated power for the STA335BWQS is:

2 x 20 W @ 8 Ω, 18 V	Pd max ~ 4 W
2 x 10 W + 1 x 20 W @ 4 Ω, 8 Ω, 18 V	Pd max < 5 W
2 x 15 W @ 16 Ω, 24 V	Pd max ~ 3 W

**Figure 24. Double-layer PCB with copper ground area and 16 vias**

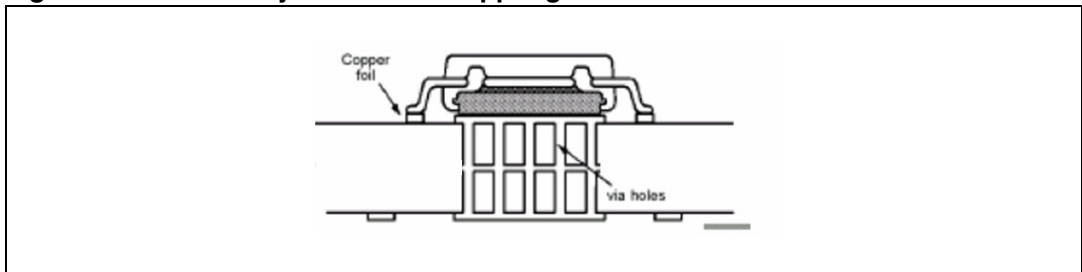

[Figure 25](#) shows the power derating curves for the PowerSSO-36 package on a board with two different sizes of copper layers.

**Figure 25. PowerSSO-36 power derating curves**

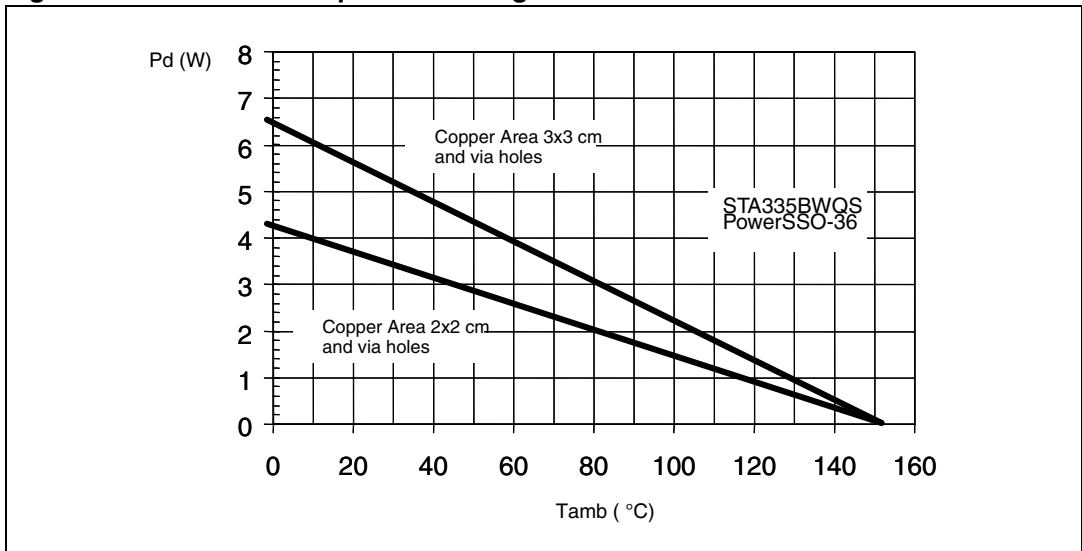

# 10 Package information

Figure 26 shows the package outline and Table 69 gives the dimensions.

Figure 26. PowerSSO-36 slug down outline drawing

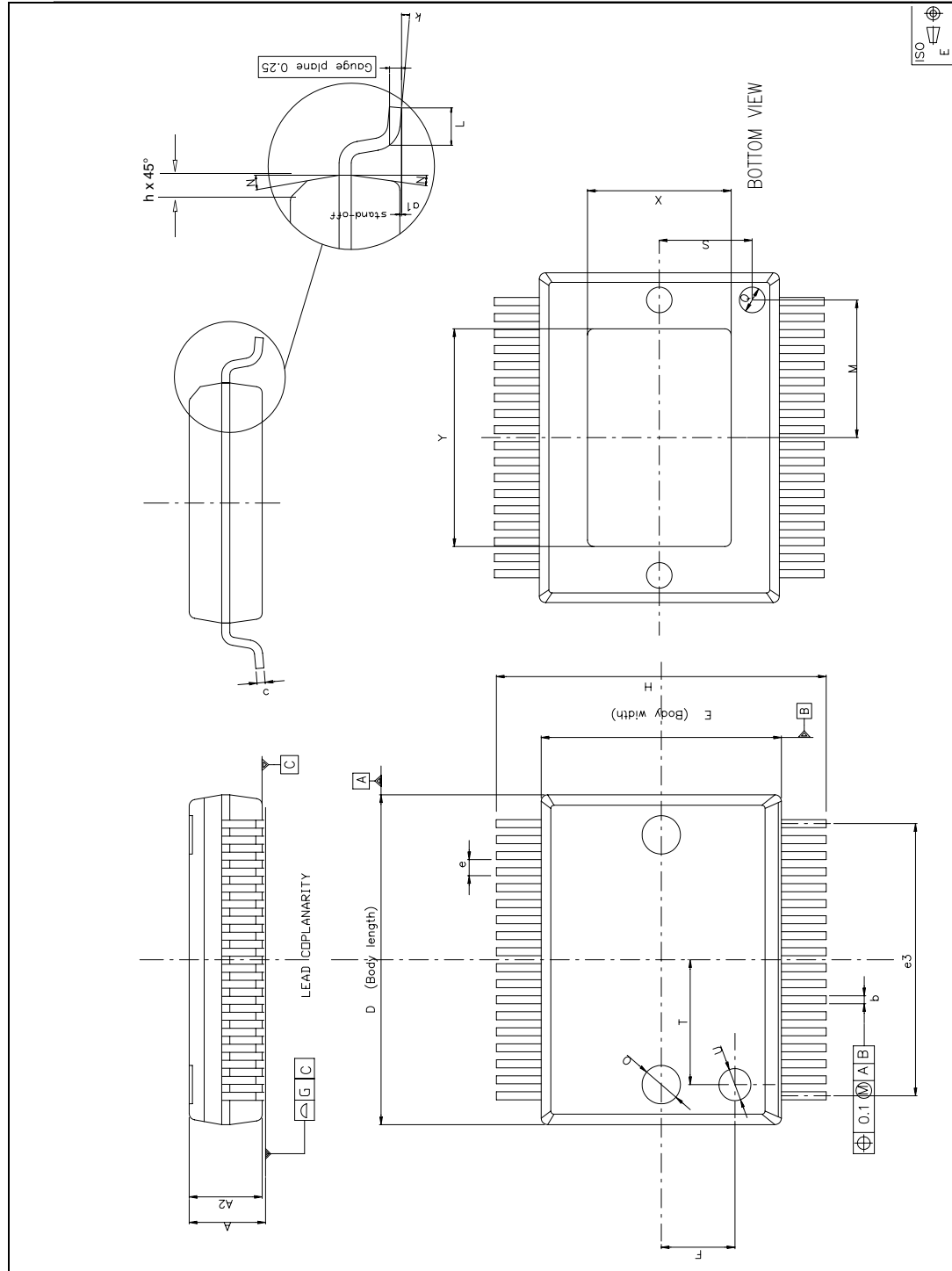

Table 69. PowerSSO-36 slug down dimensions

Symbol	mm			inch		
	Min	Typ	Max	Min	Typ	Max
A	2.15	-	2.47	0.085	-	0.097
A2	2.15	-	2.40	0.085	-	0.094
a1	0	-	0.10	0	-	0.004
b	0.18	-	0.36	0.007	-	0.014
c	0.23	-	0.32	0.009	-	0.013
D	10.10	-	10.50	0.398	-	0.413
E	7.40	-	7.60	0.291	-	0.299
e	-	0.5	-	-	0.020	
e3	-	8.5	-	-	0.335	
F	-	2.3	-	-	0.091	
G	-	-	0.10	-	-	0.004
H	10.10	-	10.50	0.398		0.413
h	-	-	0.40			0.016
k	0	-	8 degrees			8 degrees
L	0.60	-	1.00	0.024		0.039
M	-	4.30	-		0.169	
N	-	-	10 degrees			10 degrees
O	-	1.20	-		0.047	
Q	-	0.80	-		0.031	
S	-	2.90	-		0.114	
T	-	3.65	-		0.144	
U	-	1.00	-		0.039	
X	4.10		4.70	0.161		0.185
Y	6.50		7.10	0.256		0.280

In order to meet environmental requirements, ST offers these devices in ECOPACK<sup>®</sup> packages. These packages have a Lead-free second level interconnect. The category of second Level Interconnect is marked on the package and on the inner box label, in compliance with JEDEC Standard JESD97. The maximum ratings related to soldering conditions are also marked on the inner box label. ECOPACK is an ST trademark. ECOPACK specifications are available at: [www.st.com](http://www.st.com).

## 11 License information

Supply of this product does not convey a license under the relevant intellectual property of the companies mentioned in this chapter nor imply any right to use this intellectual property in any finished end-user or ready to use final product. An independent license for such use is required and can be obtained by contacting the company or companies concerned. Once the license is obtained, a copy must be sent to STMicroelectronics. The details of all the features requiring licenses are not provided within the datasheet and register manual. They are provided only after a copy of the license has been received by STMicroelectronics.

The feature requiring license is:

### **QXpander<sup>®</sup>, QHD<sup>®</sup>**

QHD<sup>®</sup> and QXpander<sup>®</sup> are intellectual property of QSound Labs Inc. A license can be obtained with the STA335BWQS via STMicroelectronics, please contact the HPC Audio Division Product Manager for details.

Alternatively the license can be obtained directly from QSound Labs Inc.

For details please contact:

sales@qsound.com

or

QSound Labs, Inc

400 - 3115 12th Street NE

Calgary, AB

Canada T2E 7J2

## 12 Trademarks and other acknowledgements

DDX is a registered trademark of Apogee Technology Inc.

AutoModes is a trademark of Apogee Technology Inc

SoundTerminal is a trademark of STMicroelectronics.

ECOPACK is a registered trademark of STMicroelectronics.

QHD and QXpander are registered trademarks of QSound Labs Inc.

## 13 Revision history

**Table 70. Document revision history**

Date	Revision	Changes
26-Mar-2008	1	Initial release
15-May-2008	2	Updated pins 19 and 20 names (4A->4B, 4B->4A) in <a href="#">Table 2 on page 12</a> Added power-off sequence, <a href="#">Figure 4 on page 18</a> Added <a href="#">Chapter 5 on page 21</a> (reset, power-down, I <sup>2</sup> S interface description) Updated release rate values in <a href="#">Table 63 on page 52</a> Updated package information in <a href="#">Chapter 10 on page 67</a>
12-Aug-2010	3	Removed erroneous watermark

**Please Read Carefully:**

Information in this document is provided solely in connection with ST products. STMicroelectronics NV and its subsidiaries ("ST") reserve the right to make changes, corrections, modifications or improvements, to this document, and the products and services described herein at any time, without notice.

All ST products are sold pursuant to ST's terms and conditions of sale.

Purchasers are solely responsible for the choice, selection and use of the ST products and services described herein, and ST assumes no liability whatsoever relating to the choice, selection or use of the ST products and services described herein.

No license, express or implied, by estoppel or otherwise, to any intellectual property rights is granted under this document. If any part of this document refers to any third party products or services it shall not be deemed a license grant by ST for the use of such third party products or services, or any intellectual property contained therein or considered as a warranty covering the use in any manner whatsoever of such third party products or services or any intellectual property contained therein.

**UNLESS OTHERWISE SET FORTH IN ST'S TERMS AND CONDITIONS OF SALE ST DISCLAIMS ANY EXPRESS OR IMPLIED WARRANTY WITH RESPECT TO THE USE AND/OR SALE OF ST PRODUCTS INCLUDING WITHOUT LIMITATION IMPLIED WARRANTIES OF MERCHANTABILITY, FITNESS FOR A PARTICULAR PURPOSE (AND THEIR EQUIVALENTS UNDER THE LAWS OF ANY JURISDICTION), OR INFRINGEMENT OF ANY PATENT, COPYRIGHT OR OTHER INTELLECTUAL PROPERTY RIGHT.**

**UNLESS EXPRESSLY APPROVED IN WRITING BY AN AUTHORIZED ST REPRESENTATIVE, ST PRODUCTS ARE NOT RECOMMENDED, AUTHORIZED OR WARRANTED FOR USE IN MILITARY, AIR CRAFT, SPACE, LIFE SAVING, OR LIFE SUSTAINING APPLICATIONS, NOR IN PRODUCTS OR SYSTEMS WHERE FAILURE OR MALFUNCTION MAY RESULT IN PERSONAL INJURY, DEATH, OR SEVERE PROPERTY OR ENVIRONMENTAL DAMAGE. ST PRODUCTS WHICH ARE NOT SPECIFIED AS "AUTOMOTIVE GRADE" MAY ONLY BE USED IN AUTOMOTIVE APPLICATIONS AT USER'S OWN RISK.**

Resale of ST products with provisions different from the statements and/or technical features set forth in this document shall immediately void any warranty granted by ST for the ST product or service described herein and shall not create or extend in any manner whatsoever, any liability of ST.

ST and the ST logo are trademarks or registered trademarks of ST in various countries.

Information in this document supersedes and replaces all information previously supplied.

The ST logo is a registered trademark of STMicroelectronics. All other names are the property of their respective owners.

© 2010 STMicroelectronics - All rights reserved

STMicroelectronics group of companies

Australia - Belgium - Brazil - Canada - China - Czech Republic - Finland - France - Germany - Hong Kong - India - Israel - Italy - Japan - Malaysia - Malta - Morocco - Singapore - Spain - Sweden - Switzerland - United Kingdom - United States of America

[www.st.com](http://www.st.com)