

## Features

- Fast Read Access Time - 70 ns
- 5-Volt-Only Reprogramming
- Sector Program Operation
  - Single Cycle Reprogram (Erase and Program)
  - 512 Sectors (128 words/sector)
  - Internal Address and Data Latches for 128 Words
- Internal Program Control and Timer
- Hardware and Software Data Protection
- Fast Sector Program Cycle Time - 10 ms
- DATA Polling for End of Program Detection
- Low Power Dissipation
  - 60 mA Active Current
  - 200  $\mu$ A CMOS Standby Current
- Typical Endurance > 10,000 Cycles
- Single 5V  $\pm$ 10% Supply
- CMOS and TTL Compatible Inputs and Outputs
- Commercial and Industrial Temperature Ranges

## Description

The AT29C1024 is a 5-volt-only in-system Flash programmable and erasable read only memory (PEROM). Its 1 megabit of memory is organized as 65,536 words by 16 bits. Manufactured with Atmel's advanced nonvolatile CMOS technology, the device offers access times to 70 ns with power dissipation of just 330 mW. When the device is deselected, the CMOS standby current is less than 200  $\mu$ A. The device endurance is such that any sector can typically be written to in excess of 10,000 times.

(continued)

**1 Megabit  
(64K x 16)  
5-volt Only  
CMOS Flash  
Memory**

## Pin Configurations

Pin Name	Function
A0 - A15	Addresses
$\overline{CE}$	Chip Enable
$\overline{OE}$	Output Enable
WE	Write Enable
I/O0 - I/O15	Data Inputs/Outputs
NC	No Connect
DC	Don't Connect

PLCC Top View

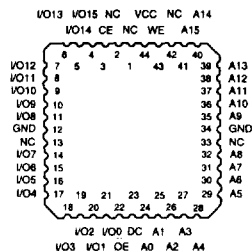

TSOP Top View  
Type 1

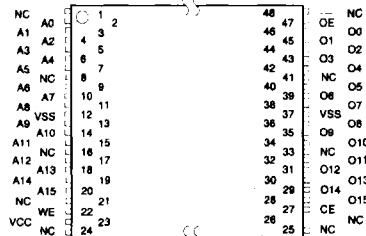

0571A



## Description (Continued)

To allow for simple in-system reprogrammability, the AT29C1024 does not require high input voltages for programming. Five-volt-only commands determine the operation of the device. Reading data out of the device is similar to reading from an EPROM. Reprogramming the AT29C1024 is performed on a sector basis; 128 words of data are loaded into the device and then simultaneously programmed.

During a reprogram cycle, the address locations and 128 words of data are internally latched, freeing the address and data bus for other operations. Following the initiation of a program cycle, the device will automatically erase the sector and then program the latched data using an internal control timer. The end of a program cycle can be detected by DATA polling of I/O7 or I/O15. Once the end of a program cycle has been detected, a new access for a read or program can begin.

## Block Diagram

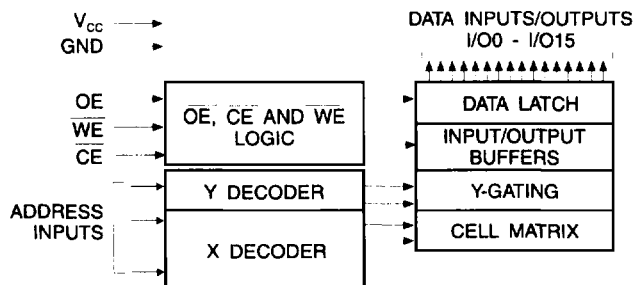

## Device Operation

**READ:** The AT29C1024 is accessed like an EPROM. When  $\overline{CE}$  and  $\overline{OE}$  are low and  $\overline{WE}$  is high, the data stored at the memory location determined by the address pins is asserted on the outputs. The outputs are put in the high impedance state whenever  $\overline{CE}$  or  $\overline{OE}$  is high. This dual-line control gives designers flexibility in preventing bus contention.

**DATA LOAD:** Data loads are used to enter the 128 words of a sector to be programmed or the software codes for data protection. A data load is performed by applying a low pulse on the  $\overline{WE}$  or  $\overline{CE}$  input with  $\overline{CE}$  or  $\overline{WE}$  low (respectively) and  $\overline{OE}$  high. The address is latched on the falling edge of  $\overline{CE}$  or  $\overline{WE}$ , whichever occurs last. The data is latched by the first rising edge of  $\overline{CE}$  or  $\overline{WE}$ .

**PROGRAM:** The device is reprogrammed on a sector basis. If a word of data within a sector is to be changed, data for the entire sector must be loaded into the device. Any word that is not loaded during the programming of its sector will be erased to read FFH. Once the words of a sector are loaded into the device, they are simultaneously programmed during the internal programming period. After the first data word has been loaded into the device, successive words are entered in the same manner. Each new word to be programmed must have its high to low transition on  $\overline{WE}$  (or  $\overline{CE}$ ) within 150  $\mu$ s of the low to high transition of  $\overline{WE}$  (or  $\overline{CE}$ ) of the preceding word. If a high to low transition is not detected within 150  $\mu$ s of the last low to high transition, the load period will end and the internal programming period will start. A7 to A15 specify the sector

address. The sector address must be valid during each high to low transition of  $\overline{WE}$  (or  $\overline{CE}$ ). A0 to A6 specify the word address within the sector. The words may be loaded in any order; sequential loading is not required. Once a programming operation has been initiated, and for the duration of  $t_{wc}$ , a read operation will effectively be a polling operation.

**SOFTWARE DATA PROTECTION:** A software controlled data protection feature is available on the AT29C1024. Once the software protection is enabled a software algorithm must be issued to the device before a program may be performed. The software protection feature may be enabled or disabled by the user; when shipped from Atmel, the software data protection feature is disabled. To enable the software data protection, a series of three program commands to specific addresses with specific data must be performed. After the software data protection is enabled the same three program commands must begin each program cycle in order for the programs to occur. All software program commands must obey the sector program timing specifications. Once set, software data protection will remain active unless the disable command sequence is issued. Power transitions will not reset the software data protection feature, however the software feature will guard against inadvertent program cycles during power transitions.

(continued)

**Device Operation (Continued)**

After setting SDP, any attempt to write to the device without the 3-word command sequence will start the internal write timers. No data will be written to the device; however, for the duration of t<sub>wc</sub>, a read operation will effectively be a polling operation.

After the software data protection's 3-word command code is given, a sector of data is loaded into the device using the sector programming timing specifications.

**HARDWARE DATA PROTECTION:** Hardware features protect against inadvertent programs to the AT29C1024 in the following ways: (a) V<sub>CC</sub> sense— if V<sub>CC</sub> is below 3.8V (typical), the program function is inhibited. (b) V<sub>CC</sub> power on delay— once V<sub>CC</sub> has reached the V<sub>CC</sub> sense level, the device will automatically time out 5 ms (typical) before programming. (c) Program inhibit— holding any one of OE low, CE high or WE high inhibits program cycles. (d) Noise filter— pulses of less than 15 ns (typical) on the WE or CE inputs will not initiate a program cycle.

**PRODUCT IDENTIFICATION:** The product identification mode identifies the device and manufacturer as Atmel. It may be accessed by hardware or software operation. The hardware operation mode can be used by an external programmer to identify the correct programming algorithm for the Atmel product. In addition, users may wish to use the software product identification mode to identify the part (i.e. using the device code), and have the system software use the appropriate sector size for program op-

erations. In this manner, the user can have a common board design for various Flash densities and, with each density's sector size in a memory map, have the system software apply the appropriate sector size.

For details, see Operating Modes (for hardware operation) or Software Product Identification. The manufacturer and device code is the same for both modes.

**DATA POLLING:** The AT29C1024 features  $\overline{\text{DATA}}$  polling to indicate the end of a program cycle. During a program cycle an attempted read of the last word loaded will result in the complement of the loaded data on I/O7 and I/O15. Once the program cycle has been completed, true data is valid on all outputs and the next cycle may begin. DATA polling may begin at any time during the program cycle.

**TOGGLE BIT:** In addition to  $\overline{\text{DATA}}$  polling the AT29C1024 provides another method for determining the end of a program or erase cycle. During a program or erase operation, successive attempts to read data from the device will result in I/O6 and I/O14 toggling between one and zero. Once the program cycle has completed, I/O6 and I/O14 will stop toggling and valid data will be read. Examining the toggle bit may begin at any time during a program cycle.

**OPTIONAL CHIP ERASE MODE:** The entire device can be erased by using a 6-byte software code. Please see Software Chip Erase application note for details.

**Absolute Maximum Ratings\***

Temperature Under Bias.....	-55°C to +125°C
Storage Temperature.....	-65°C to +150°C
All Input Voltages (including NC Pins)	
with Respect to Ground .....	-0.6V to +6.25V
All Output Voltages	
with Respect to Ground .....	-0.6V to V <sub>CC</sub> + 0.6V
Voltage on $\overline{\text{OE}}$	
with Respect to Ground .....	-0.6V to +13.5V

\*NOTICE: Stresses beyond those listed under "Absolute Maximum Ratings" may cause permanent damage to the device. This is a stress rating only and functional operation of the device at these or any other conditions beyond those indicated in the operational sections of this specification is not implied. Exposure to absolute maximum rating conditions for extended periods may affect device reliability.





## DC and AC Operating Range

		AT29C1024-70	AT29C1024-90	AT29C1024-12	AT29C1024-15
Operating Temperature (Case)	Com.	0°C - 70°C	0°C - 70°C	0°C - 70°C	0°C - 70°C
	Ind.	-40°C - 85°C	-40°C - 85°C	-40°C - 85°C	-40°C - 85°C
V <sub>CC</sub> Power Supply		5V ± 5%	5V ± 10%	5V ± 10%	5V ± 10%

## Operating Modes

Mode	$\overline{CE}$	$\overline{OE}$	$\overline{WE}$	AI	I/O
Read	V <sub>IL</sub>	V <sub>IL</sub>	V <sub>IH</sub>	Ai	D <sub>OUT</sub>
Program <sup>(2)</sup>	V <sub>IL</sub>	V <sub>IH</sub>	V <sub>IL</sub>	Ai	D <sub>IN</sub>
5V Chip Erase	V <sub>IL</sub>	V <sub>IH</sub>	V <sub>IL</sub>	Ai	
Standby/Write Inhibit	V <sub>IH</sub>	X <sup>(1)</sup>	X	X	High Z
Program Inhibit	X	X	V <sub>IH</sub>		
Program Inhibit	X	V <sub>IL</sub>	X		
Output Disable	X	V <sub>IH</sub>	X		High Z
Product Identification					
Hardware	V <sub>IL</sub>	V <sub>IL</sub>	V <sub>IH</sub>	A1 - A15 = V <sub>IL</sub> , A9 = V <sub>H</sub> , <sup>(3)</sup> A0 = V <sub>IL</sub>	Manufacturer Code <sup>(4)</sup>
				A1 - A15 = V <sub>IL</sub> , A9 = V <sub>H</sub> , <sup>(3)</sup> A0 = V <sub>IH</sub>	Device Code <sup>(4)</sup>
Software <sup>(5)</sup>				A0 = V <sub>IL</sub>	Manufacturer Code <sup>(4)</sup>
				A0 = V <sub>IH</sub>	Device Code <sup>(4)</sup>

Notes: 1. X can be V<sub>IL</sub> or V<sub>IH</sub>.

2. Refer to AC Programming Waveforms.

3. V<sub>H</sub> = 12.0V ± 0.5V.

4. Manufacturer Code: 1F, Device Code: 25

5. See details under Software Product Identification Entry/Exit.

## DC Characteristics

Symbol	Parameter	Condition	Min	Max	Units
I <sub>LI</sub>	Input Load Current	V <sub>IN</sub> = 0V to V <sub>CC</sub>		10	μA
I <sub>LO</sub>	Output Leakage Current	V <sub>I/O</sub> = 0V to V <sub>CC</sub>		10	μA
I <sub>SB1</sub>	V <sub>CC</sub> Standby Current CMOS	$\overline{CE} = V_{CC} - 0.3V$ to V <sub>CC</sub>	Com.	200	μA
			Ind.	200	μA
I <sub>SB2</sub>	V <sub>CC</sub> Standby Current TTL	$\overline{CE} = 2.0V$ to V <sub>CC</sub>		3	mA
I <sub>CC</sub>	V <sub>CC</sub> Active Current	f = 5 MHz; I <sub>OUT</sub> = 0 mA		60	mA
V <sub>IL</sub>	Input Low Voltage			0.8	V
V <sub>IH</sub>	Input High Voltage		2.0		V
V <sub>OL</sub>	Output Low Voltage	I <sub>OL</sub> = 2.1 mA		.45	V
V <sub>OH1</sub>	Output High Voltage	I <sub>OH</sub> = -400 μA	2.4		V
V <sub>OH2</sub>	Output High Voltage CMOS	I <sub>OH</sub> = -100 μA; V <sub>CC</sub> = 4.5V	4.2		V

## AC Read Characteristics

Symbol	Parameter	AT29C1024-70		AT29C1024-90		AT29C1024-12		AT29C1024-15		Units
		Min	Max	Min	Max	Min	Max	Min	Max	
$t_{ACC}$	Address to Output Delay		70		90		120		150	ns
$t_{CE}^{(1)}$	$\overline{CE}$ to Output Delay		70		90		120		150	ns
$t_{OE}^{(2)}$	$\overline{OE}$ to Output Delay	0	35	0	45	0	60	0	70	ns
$t_{DF}^{(3,4)}$	$\overline{CE}$ or $\overline{OE}$ to Output Float	0	25	0	25	0	30	0	40	ns
$t_{OH}$	Output Hold from $\overline{OE}$ , $\overline{CE}$ or Address, whichever occurred first	0		0		0		0		ns

## AC Read Waveforms (1, 2, 3, 4)

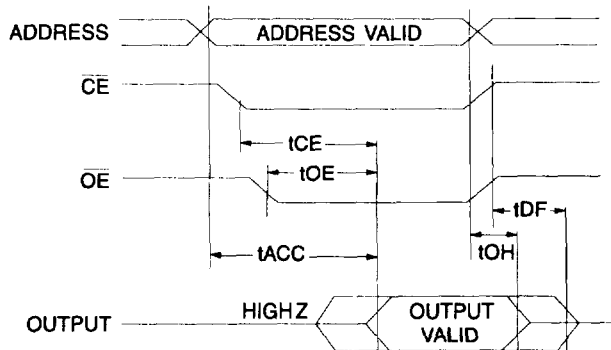

- Notes:
- $\overline{CE}$  may be delayed up to  $t_{ACC} - t_{CE}$  after the address transition without impact on  $t_{ACC}$ .
  - $\overline{OE}$  may be delayed up to  $t_{CE} - t_{OE}$  after the falling edge of  $\overline{CE}$  without impact on  $t_{CE}$  or by  $t_{ACC} - t_{OE}$  after an address change without impact on  $t_{ACC}$ .

- $t_{DF}$  is specified from  $\overline{OE}$  or  $\overline{CE}$  whichever occurs first ( $C_L = 5 \text{ pF}$ ).
- This parameter is characterized and is not 100% tested.

## Input Test Waveforms and Measurement Level

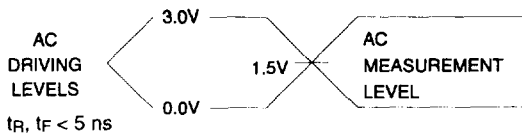

## Output Test Load

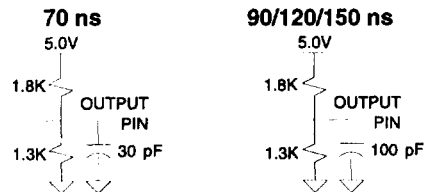

## Pin Capacitance ( $f = 1 \text{ MHz}, T = 25^\circ\text{C}$ )<sup>(1)</sup>

	Typ	Max	Units	Conditions
$C_{IN}$	4	6	pF	$V_{IN} = 0\text{V}$
$C_{OUT}$	8	12	pF	$V_{OUT} = 0\text{V}$

Note: 1. This parameter is characterized and is not 100% tested.





## AC Word Load Characteristics

Symbol	Parameter	Min	Max	Units
$t_{AS}, t_{OES}$	Address, $\overline{OE}$ Set-up Time	0		ns
$t_{AH}$	Address Hold Time	50		ns
$t_{CS}$	Chip Select Set-up Time	0		ns
$t_{CH}$	Chip Select Hold Time	0		ns
$t_{WP}$	Write Pulse Width ( $\overline{WE}$ or $\overline{CE}$ )	70		ns
$t_{DS}$	Data Set-up Time	50		ns
$t_{DH}, t_{OEH}$	Data, $\overline{OE}$ Hold Time	0		ns
$t_{WPH}$	Write Pulse Width High	100		ns

## AC Word Load Waveforms

### $\overline{WE}$ Controlled

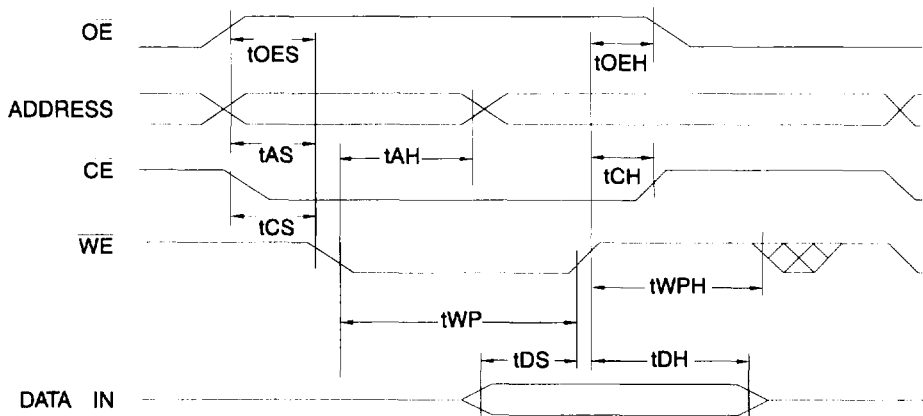

### $\overline{CE}$ Controlled

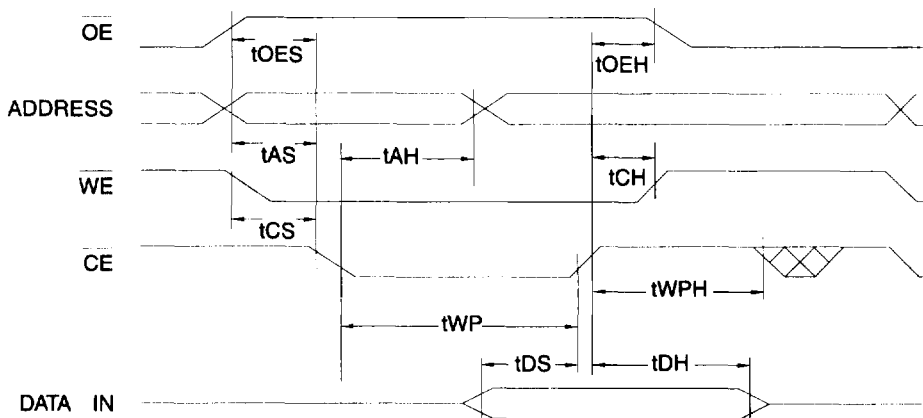

Program Cycle Characteristics

Symbol	Parameter	Min	Max	Units
t <sub>WC</sub>	Write Cycle Time		10	ms
t <sub>AS</sub>	Address Set-up Time	0		ns
t <sub>AH</sub>	Address Hold Time	50		ns
t <sub>DS</sub>	Data Set-up Time	50		ns
t <sub>DH</sub>	Data Hold Time	0		ns
t <sub>WP</sub>	Write Pulse Width	70		ns
t <sub>WLC</sub>	Word Load Cycle Time		150	μs
t <sub>WPH</sub>	Write Pulse Width High	100		ns

Program Cycle Waveforms (1, 2, 3)

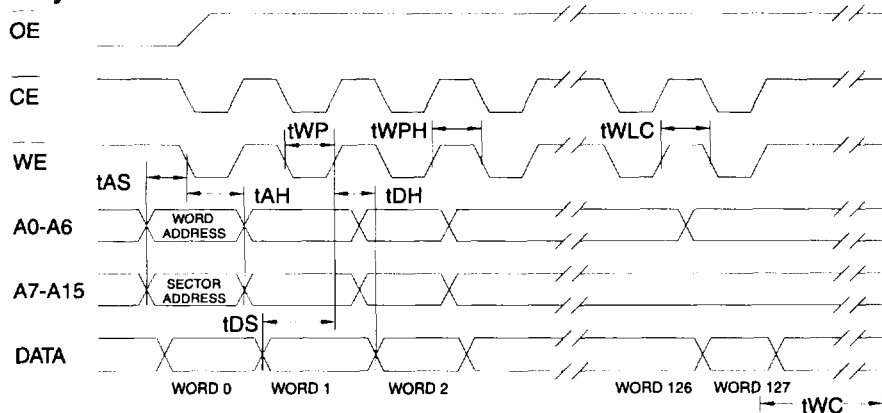

4

- Notes: 1. A7 through A15 must specify the sector address during each high to low transition of WE (or CE).  
 2. OE must be high when WE and CE are both low.

3. All words that are not loaded within the sector being programmed will be indeterminate.





## Software Data Protection Enable Algorithm <sup>(1)</sup>

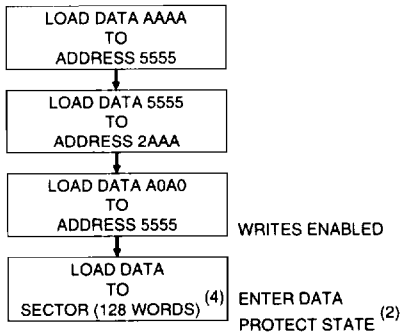

## Software Data Protection Disable Algorithm <sup>(1)</sup>

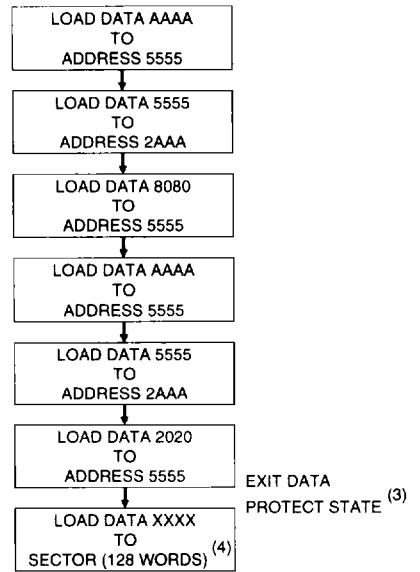

Notes for software program code:

1. Data Format: I/O15 - I/O0 (Hex); Address Format: A14 - A0 (Hex).
2. Write Protect state will be activated at end of write period even if no other data is loaded.
3. Write Protect state will be deactivated at end of write period even if no other data is loaded.
4. 128 words of data **MUST BE** loaded.

## Software Protected Program Cycle Waveform <sup>(1, 2, 3)</sup>

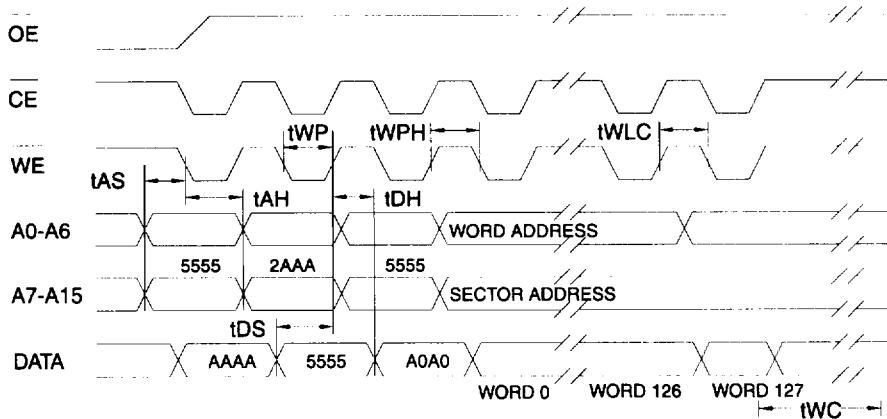

- Notes: 1. A7 through A15 must specify the same page address during each high to low transition of WE (or CE) after the software code has been entered.

2. OE must be high when WE and CE are both low.
3. All words that are not loaded within the sector being programmed will be indeterminate.



Data Polling Characteristics <sup>(1)</sup>

Symbol	Parameter	Min	Typ	Max	Units
t <sub>DH</sub>	Data Hold Time	0			ns
t <sub>OE<math>\bar{H}</math></sub>	$\overline{OE}$ Hold Time	0			ns
t <sub>OE</sub>	$\overline{OE}$ to Output Delay <sup>(2)</sup>				ns
t <sub>WR</sub>	Write Recovery Time	0			ns

Notes: 1. These parameters are characterized and not 100% tested.  
 2. See t<sub>OE</sub> spec in AC Read Characteristics.

Data Polling Waveforms

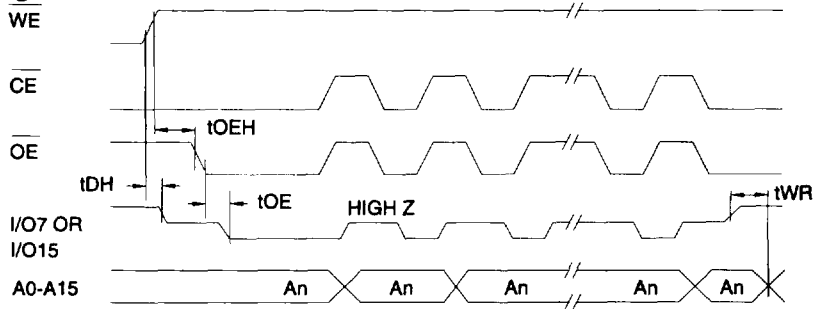

4

Toggle Bit Characteristics <sup>(1)</sup>

Symbol	Parameter	Min	Typ	Max	Units
t <sub>DH</sub>	Data Hold Time	10			ns
t <sub>OE<math>\bar{H}</math></sub>	$\overline{OE}$ Hold Time	10			ns
t <sub>OE</sub>	$\overline{OE}$ to Output Delay <sup>(2)</sup>				ns
t <sub>OEHP</sub>	$\overline{OE}$ High Pulse	150			ns
t <sub>WR</sub>	Write Recovery Time	0			ns

Notes: 1. These parameters are characterized and not 100% tested.  
 2. See t<sub>OE</sub> spec in AC Read Characteristics.

Toggle Bit Waveforms <sup>(1, 2, 3)</sup>

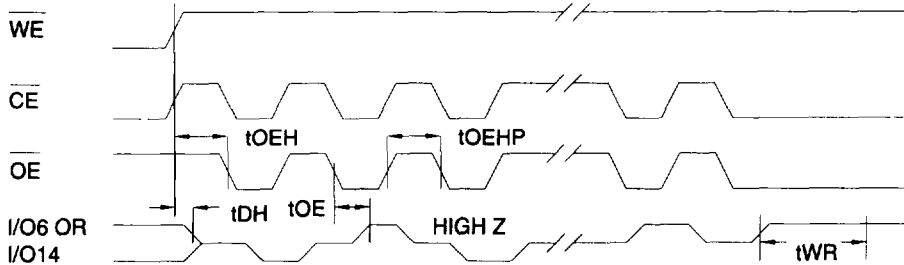

Notes: 1. Toggling either  $\overline{OE}$  or  $\overline{CE}$  or both  $\overline{OE}$  and  $\overline{CE}$  will operate toggle bit.  
 2. Beginning and ending state of I/O6 and I/O14 may vary.  
 3. Any address location may be used but the address should not vary.



## Software Product Identification Entry <sup>(1)</sup>

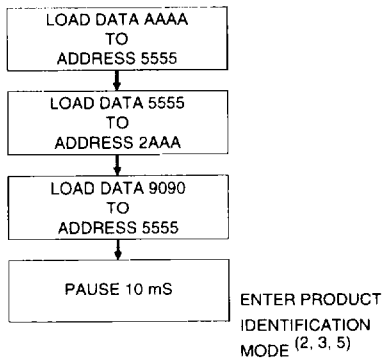

## Software Product Identification Exit <sup>(1)</sup>

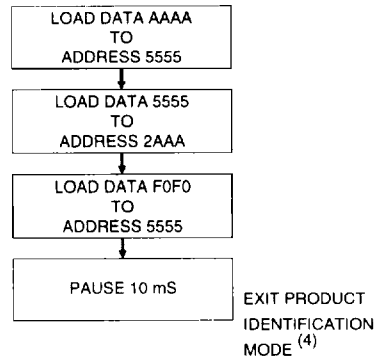

Notes for software product identification:

1. Data Format: I/O15 - I/O0 (Hex);  
Address Format: A14 - A0 (Hex).
2. A1 - A15 = V<sub>IL</sub>.  
Manufacture Code is read for A0 = V<sub>IL</sub>;  
Device Code is read for A0 = V<sub>IH</sub>.
3. The device does not remain in identification mode if powered down.
4. The device returns to standard operation mode.
5. Manufacturer Code: 1F  
Device Code: 25

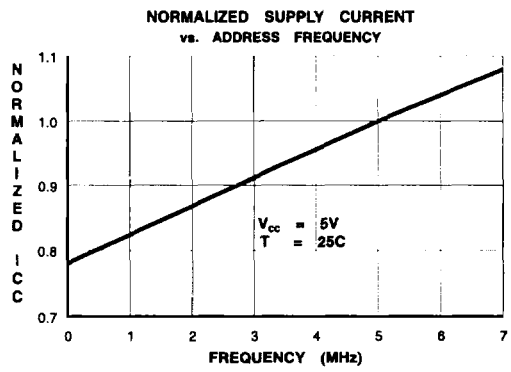
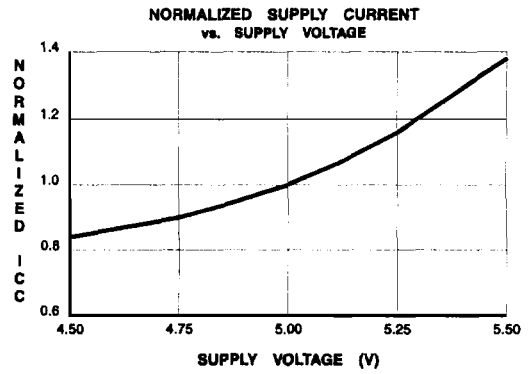
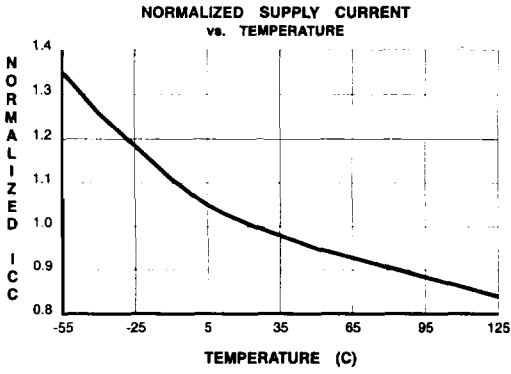

4





## Ordering Information

t <sub>ACC</sub> (ns)	I <sub>CC</sub> (mA)		Ordering Code	Package	Operation Range
	Active	Standby			
70	60	0.1	AT29C1024-70JC AT29C1024-70TC	44J 48T	Commercial (0° to 70°C)
	60	0.3	AT29C1024-70JI AT29C1024-70TI	44J 48T	Industrial (-40° to 85°C)
90	60	0.1	AT29C1024-90JC AT29C1024-90TC	44J 48T	Commercial (0° to 70°C)
	60	0.3	AT29C1024-90JI AT29C1024-90TI	44J 48T	Industrial (-40° to 85°C)
120	60	0.1	AT29C1024-12JC AT29C1024-12TC	44J 48T	Commercial (0° to 70°C)
	60	0.3	AT29C1024-12JI AT29C1024-12TI	44J 48T	Industrial (-40° to 85°C)
150	60	0.1	AT29C1024-15JC AT29C1024-15TC	44J 48T	Commercial (0° to 70°C)
	60	0.3	AT29C1024-15JI AT29C1024-15TI	44J 48T	Industrial (-40° to 85°C)

Package Type	
44J	44 Lead, Plastic J-Leaded Chip Carrier (PLCC)
48T	48 Lead, Thin Small Outline Package (TSOP)