Features

- Fast Read Access Time – 150 ns
- Automatic Page Write Operation
 - Internal Address and Data Latches for 64 Bytes
 - Internal Control Timer
- Fast Write Cycle Times
 - Page Write Cycle Time: 3 ms or 10 ms Maximum
 - 1 to 64-byte Page Write Operation
- Low Power Dissipation
 - 50 mA Active Current
 - 200 μ A CMOS Standby Current
- Hardware and Software Data Protection
- $\overline{\text{DATA}}$ Polling for End of Write Detection
- High Reliability CMOS Technology
 - Endurance: 10^4 or 10^5 Cycles
 - Data Retention: 10 Years
- Single 5V \pm 10% Supply
- CMOS and TTL Compatible Inputs and Outputs
- JEDEC Approved Byte-wide Pinout
- Full Military, Commercial, and Industrial Temperature Ranges
- Green (Pb/Halide-free) Packaging Option

1. Description

The AT28C256 is a high-performance electrically erasable and programmable read-only memory. Its 256K of memory is organized as 32,768 words by 8 bits. Manufactured with Atmel's advanced nonvolatile CMOS technology, the device offers access times to 150 ns with power dissipation of just 440 mW. When the device is deselected, the CMOS standby current is less than 200 μ A.

The AT28C256 is accessed like a Static RAM for the read or write cycle without the need for external components. The device contains a 64-byte page register to allow writing of up to 64 bytes simultaneously. During a write cycle, the addresses and 1 to 64 bytes of data are internally latched, freeing the address and data bus for other operations. Following the initiation of a write cycle, the device will automatically write the latched data using an internal control timer. The end of a write cycle can be detected by $\overline{\text{DATA}}$ Polling of I/O7. Once the end of a write cycle has been detected a new access for a read or write can begin.

Atmel's AT28C256 has additional features to ensure high quality and manufacturability. The device utilizes internal error correction for extended endurance and improved data retention characteristics. An optional software data protection mechanism is available to guard against inadvertent writes. The device also includes an extra 64 bytes of EEPROM for device identification or tracking.



**256K (32K x 8)
Paged Parallel
EEPROM**

AT28C256



2. Pin Configurations

Pin Name	Function
A0 - A14	Addresses
\overline{CE}	Chip Enable
\overline{OE}	Output Enable
\overline{WE}	Write Enable
I/O0 - I/O7	Data Inputs/Outputs
NC	No Connect
DC	Don't Connect

2.1 28-lead TSOP Top View

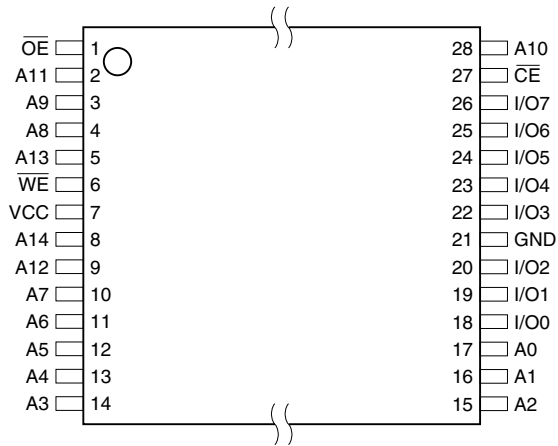

2.3 32-pad LCC, 28-lead PLCC Top View

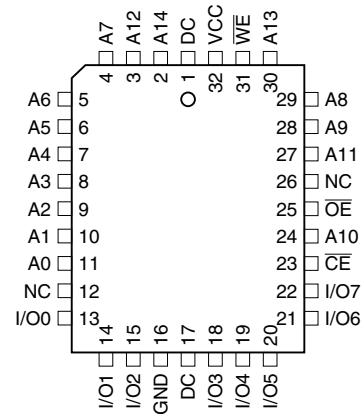

Note: PLCC package pins 1 and 17 are Don't Connect.

2.2 28-lead PGA Top View

4 A6	3 A7	1 A14	27 \overline{WE}	26 A13
5 A5	2 A12	28 VCC	24 A9	25 A8
7 A3	6 A4		22 \overline{OE}	23 A11
9 A1	8 A2		20 \overline{CE}	21 A10
11 I/O0	10 A0	14 GND	16 I/O4	19 I/O7
12 I/O1	13 I/O2	15 I/O3	17 I/O5	18 I/O6

2.4 28-lead Cerdip/PDIP/Flatpack/SOIC – Top View

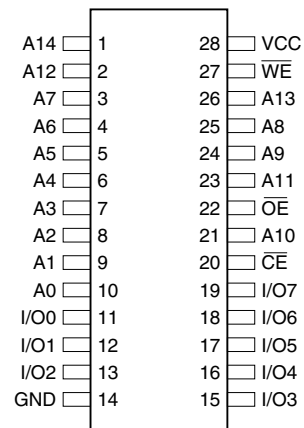

3. Block Diagram

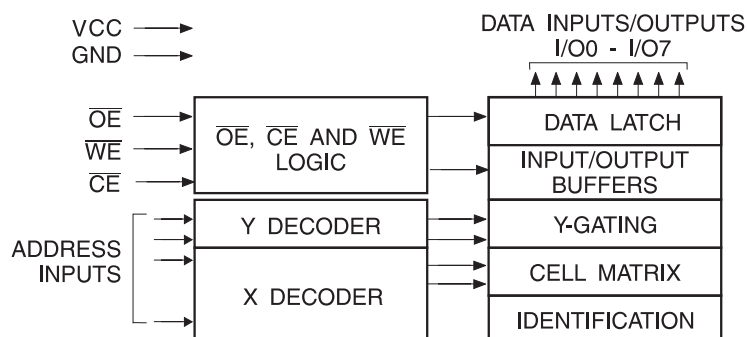

4. Device Operation

4.1 Read

The AT28C256 is accessed like a Static RAM. When \overline{CE} and \overline{OE} are low and \overline{WE} is high, the data stored at the memory location determined by the address pins is asserted on the outputs. The outputs are put in the high impedance state when either \overline{CE} or \overline{OE} is high. This dual-line control gives designers flexibility in preventing bus contention in their system.

4.2 Byte Write

A low pulse on the \overline{WE} or \overline{CE} input with \overline{CE} or \overline{WE} low (respectively) and \overline{OE} high initiates a write cycle. The address is latched on the falling edge of \overline{CE} or \overline{WE} , whichever occurs last. The data is latched by the first rising edge of \overline{CE} or \overline{WE} . Once a byte write has been started it will automatically time itself to completion. Once a programming operation has been initiated and for the duration of t_{WC} , a read operation will effectively be a polling operation.

4.3 Page Write

The page write operation of the AT28C256 allows 1 to 64 bytes of data to be written into the device during a single internal programming period. A page write operation is initiated in the same manner as a byte write; the first byte written can then be followed by 1 to 63 additional bytes. Each successive byte must be written within $150 \mu s$ (t_{BLC}) of the previous byte. If the t_{BLC} limit is exceeded the AT28C256 will cease accepting data and commence the internal programming operation. All bytes during a page write operation must reside on the same page as defined by the state of the A6 - A14 inputs. For each \overline{WE} high to low transition during the page write operation, A6 - A14 must be the same.

The A0 to A5 inputs are used to specify which bytes within the page are to be written. The bytes may be loaded in any order and may be altered within the same load period. Only bytes which are specified for writing will be written; unnecessary cycling of other bytes within the page does not occur.

4.4 \overline{DATA} Polling

The AT28C256 features \overline{DATA} Polling to indicate the end of a write cycle. During a byte or page write cycle an attempted read of the last byte written will result in the complement of the written data to be presented on I/O7. Once the write cycle has been completed, true data is valid on all outputs, and the next write cycle may begin. \overline{DATA} Polling may begin at anytime during the write cycle.



4.5 Toggle Bit

In addition to $\overline{\text{DATA}}$ Polling the AT28C256 provides another method for determining the end of a write cycle. During the write operation, successive attempts to read data from the device will result in I/O6 toggling between one and zero. Once the write has completed, I/O6 will stop toggling and valid data will be read. Reading the toggle bit may begin at any time during the write cycle.

4.6 Data Protection

If precautions are not taken, inadvertent writes may occur during transitions of the host system power supply. Atmel has incorporated both hardware and software features that will protect the memory against inadvertent writes.

4.6.1 Hardware Protection

Hardware features protect against inadvertent writes to the AT28C256 in the following ways: (a) V_{CC} sense – if V_{CC} is below 3.8V (typical) the write function is inhibited; (b) V_{CC} power-on delay – once V_{CC} has reached 3.8V the device will automatically time out 5 ms (typical) before allowing a write; (c) write inhibit – holding any one of $\overline{\text{OE}}$ low, $\overline{\text{CE}}$ high or $\overline{\text{WE}}$ high inhibits write cycles; and (d) noise filter – pulses of less than 15 ns (typical) on the $\overline{\text{WE}}$ or $\overline{\text{CE}}$ inputs will not initiate a write cycle.

4.6.2 Software Data Protection

A software controlled data protection feature has been implemented on the AT28C256. When enabled, the software data protection (SDP), will prevent inadvertent writes. The SDP feature may be enabled or disabled by the user; the AT28C256 is shipped from Atmel with SDP disabled.

SDP is enabled by the host system issuing a series of three write commands; three specific bytes of data are written to three specific addresses (refer to “Software Data Protection” algorithm). After writing the 3-byte command sequence and after t_{WC} the entire AT28C256 will be protected against inadvertent write operations. It should be noted, that once protected the host may still perform a byte or page write to the AT28C256. This is done by preceding the data to be written by the same 3-byte command sequence used to enable SDP.

Once set, SDP will remain active unless the disable command sequence is issued. Power transitions do not disable SDP and SDP will protect the AT28C256 during power-up and power-down conditions. All command sequences must conform to the page write timing specifications. The data in the enable and disable command sequences is not written to the device and the memory addresses used in the sequence may be written with data in either a byte or page write operation.

After setting SDP, any attempt to write to the device without the 3-byte command sequence will start the internal write timers. No data will be written to the device; however, for the duration of t_{WC} , read operations will effectively be polling operations.

4.7 Device Identification

An extra 64 bytes of EEPROM memory are available to the user for device identification. By raising A9 to $12V \pm 0.5V$ and using address locations 7FC0H to 7FFFH the additional bytes may be written to or read from in the same manner as the regular memory array.

4.8 Optional Chip Erase Mode

The entire device can be erased using a 6-byte software code. Please see “Software Chip Erase” application note for details.

5. DC and AC Operating Range

		AT28C256-15	AT28C256-20	AT28C256-25	AT28C256-35
Operating Temperature (Case)	Com.	0°C - 70°C	0°C - 70°C	0°C - 70°C	
	Ind.	-40°C - 85°C	-40°C - 85°C	-40°C - 85°C	
	Mil.	-55°C - 125°C	-55°C - 125°C	-55°C - 125°C	-55°C - 125°C
V _{CC} Power Supply		5V ± 10%	5V ± 10%	5V ± 10%	5V ± 10%

6. Operating Modes

Mode	\overline{CE}	\overline{OE}	\overline{WE}	I/O
Read	V _{IL}	V _{IL}	V _{IH}	D _{OUT}
Write ⁽²⁾	V _{IL}	V _{IH}	V _{IL}	D _{IN}
Standby/Write Inhibit	V _{IH}	X ⁽¹⁾	X	High Z
Write Inhibit	X	X	V _{IH}	
Write Inhibit	X	V _{IL}	X	
Output Disable	X	V _{IH}	X	High Z
Chip Erase	V _{IL}	V _H ⁽³⁾	V _{IL}	High Z

Notes: 1. X can be V_{IL} or V_{IH}.

2. Refer to AC programming waveforms.

3. V_H = 12.0V ± 0.5V.

7. Absolute Maximum Ratings*

Temperature under Bias	-55°C to +125°C
Storage Temperature	-65°C to +150°C
All Input Voltages (including NC Pins) with Respect to Ground	-0.6V to +6.25V
All Output Voltages with Respect to Ground	-0.6V to V _{CC} + 0.6V
Voltage on \overline{OE} and A9 with Respect to Ground	-0.6V to +13.5V

*NOTICE: Stresses beyond those listed under “Absolute Maximum Ratings” may cause permanent damage to the device. This is a stress rating only and functional operation of the device at these or any other conditions beyond those indicated in the operational sections of this specification is not implied. Exposure to absolute maximum rating conditions for extended periods may affect device reliability

8. DC Characteristics

Symbol	Parameter	Condition	Min	Max	Units
I _{LI}	Input Load Current	V _{IN} = 0V to V _{CC} + 1V		10	μA
I _{LO}	Output Leakage Current	V _{I/O} = 0V to V _{CC}		10	μA
I _{SB1}	V _{CC} Standby Current CMOS	$\overline{CE} = V_{CC} - 0.3V$ to V _{CC} + 1V	Com., Ind.	200	μA
			Mil.	300	μA
I _{SB2}	V _{CC} Standby Current TTL	$\overline{CE} = 2.0V$ to V _{CC} + 1V		3	mA
I _{CC}	V _{CC} Active Current	f = 5 MHz; I _{OUT} = 0 mA		50	mA
V _{IL}	Input Low Voltage			0.8	V
V _{IH}	Input High Voltage		2.0		V
V _{OL}	Output Low Voltage	I _{OL} = 2.1 mA		0.45	V
V _{OH}	Output High Voltage	I _{OH} = -400 μA	2.4		V

9. AC Read Characteristics

Symbol	Parameter	AT28C256-15		AT28C256-20		AT28C256-25		AT28C256-35		Units
		Min	Max	Min	Max	Min	Max	Min	Max	
t_{ACC}	Address to Output Delay		150		200		250		350	ns
$t_{CE}^{(1)}$	\overline{CE} to Output Delay		150		200		250		350	ns
$t_{OE}^{(2)}$	\overline{OE} to Output Delay	0	70	0	80	0	100	0	100	ns
$t_{DF}^{(3)(4)}$	\overline{CE} or \overline{OE} to Output Float	0	50	0	55	0	60	0	70	ns
t_{OH}	Output Hold from \overline{OE} , \overline{CE} or Address, whichever occurred first	0		0		0		0		ns

10. AC Read Waveforms⁽¹⁾⁽²⁾⁽³⁾⁽⁴⁾

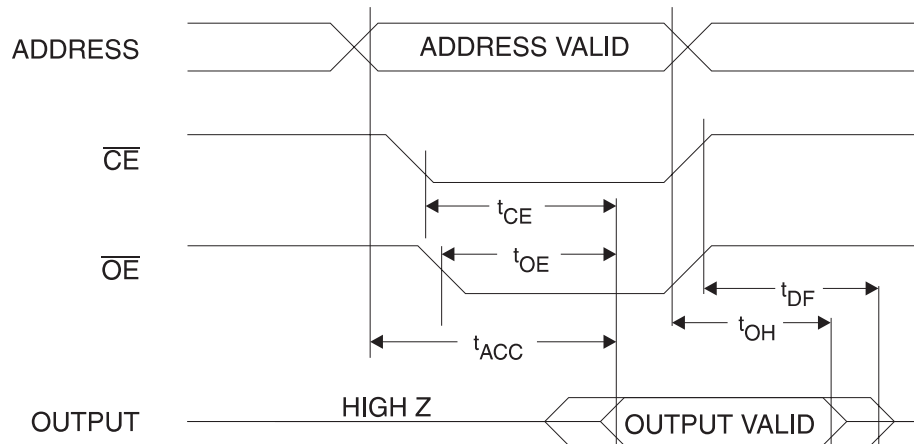

- Notes:
- \overline{CE} may be delayed up to $t_{ACC} - t_{CE}$ after the address transition without impact on t_{ACC} .
 - \overline{OE} may be delayed up to $t_{CE} - t_{OE}$ after the falling edge of \overline{CE} without impact on t_{CE} or by $t_{ACC} - t_{OE}$ after an address change without impact on t_{ACC} .
 - t_{DF} is specified from \overline{OE} or \overline{CE} whichever occurs first ($C_L = 5$ pF).
 - This parameter is characterized and is not 100% tested.

11. Input Test Waveforms and Measurement Level

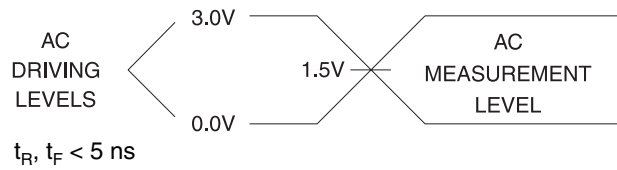

12. Output Test Load

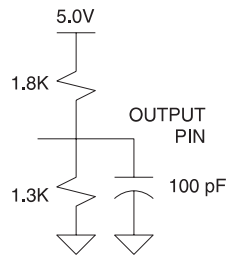

13. Pin Capacitance

f = 1 MHz, T = 25°C⁽¹⁾

Symbol	Typ	Max	Units	Conditions
C _{IN}	4	6	pF	V _{IN} = 0V
C _{OUT}	8	12	pF	V _{OUT} = 0V

Note: 1. This parameter is characterized and is not 100% tested.

14. AC Write Characteristics

Symbol	Parameter	Min	Max	Units
t_{AS}, t_{OES}	Address, \overline{OE} Setup Time	0		ns
t_{AH}	Address Hold Time	50		ns
t_{CS}	Chip Select Setup Time	0		ns
t_{CH}	Chip Select Hold Time	0		ns
t_{WP}	Write Pulse Width (\overline{WE} or \overline{CE})	100		ns
t_{DS}	Data Setup Time	50		ns
t_{DH}, t_{OEH}	Data, \overline{OE} Hold Time	0		ns
t_{DV}	Time to Data Valid	NR ⁽¹⁾		

Note: 1. NR = No Restriction

15. AC Write Waveforms

15.1 \overline{WE} Controlled

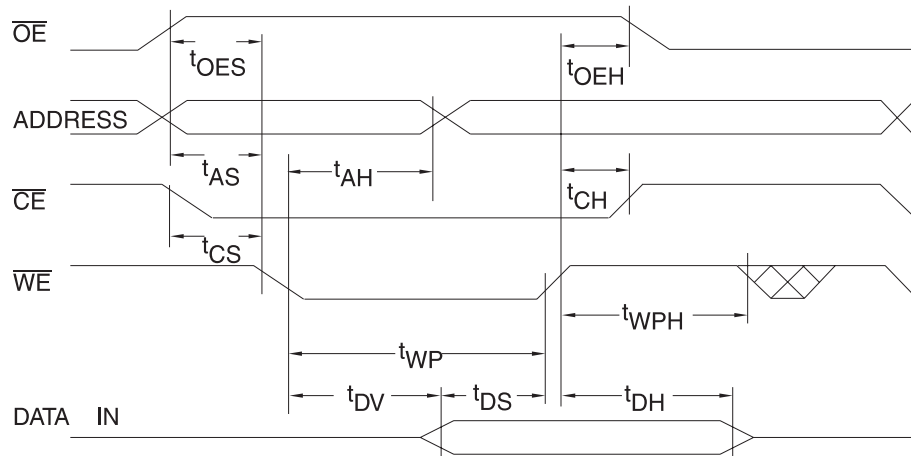

15.2 \overline{CE} Controlled

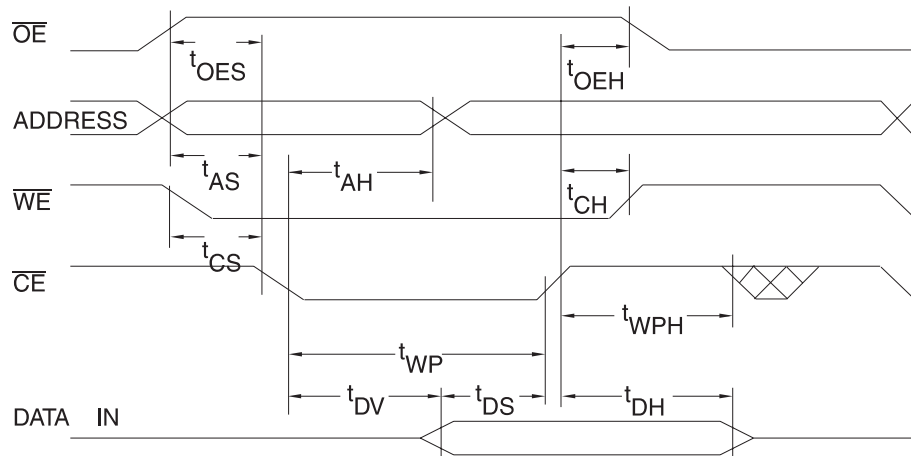

16. Page Mode Characteristics

Symbol	Parameter	Min	Max	Units
t _{WC}	Write Cycle Time (option available)	AT28C256	10	ms
		AT28C256F	3	ms
t _{AS}	Address Setup Time	0		ns
t _{AH}	Address Hold Time	50		ns
t _{DS}	Data Setup Time	50		ns
t _{DH}	Data Hold Time	0		ns
t _{WP}	Write Pulse Width	100		ns
t _{BLC}	Byte Load Cycle Time		150	μs
t _{WPH}	Write Pulse Width High	50		ns

17. Page Mode Write Waveforms⁽¹⁾⁽²⁾

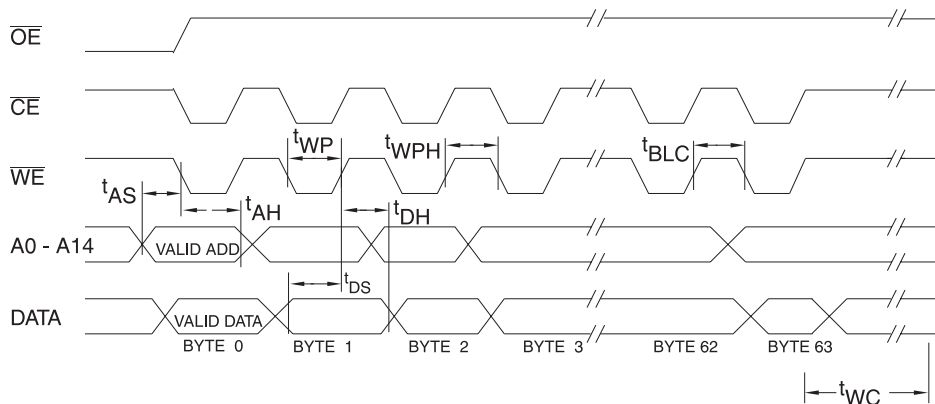

- Notes: 1. A6 through A14 must specify the same page address during each high to low transition of \overline{WE} (or \overline{CE}).
 2. \overline{OE} must be high only when \overline{WE} and \overline{CE} are both low.

18. Chip Erase Waveforms

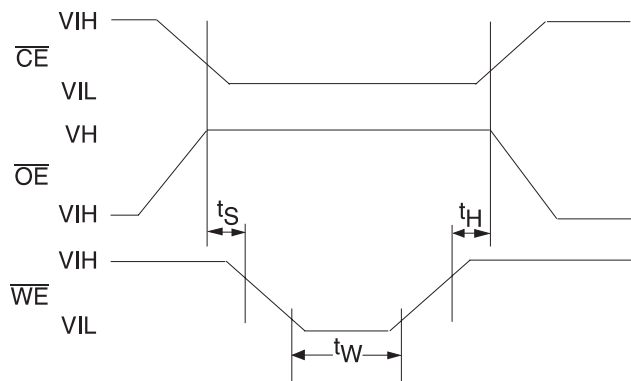

t_S = t_H = 5 μsec (min.)
 t_W = 10 msec (min.)
 V_H = 12.0V ± 0.5V

19. Software Data Protection Enable Algorithm⁽¹⁾

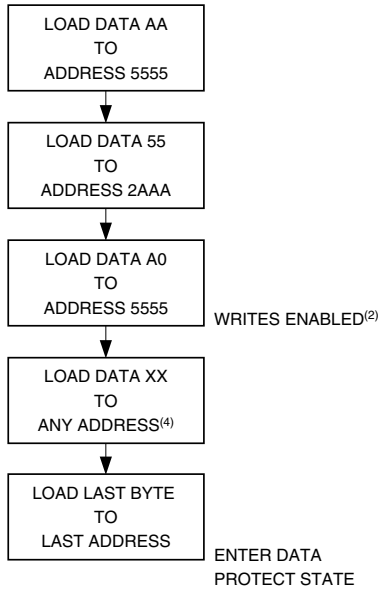

20. Software Data Protection Disable Algorithm⁽¹⁾

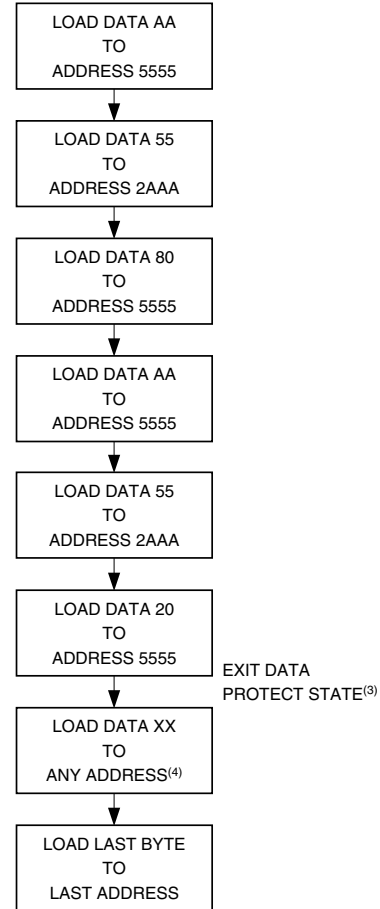

- Notes:
1. Data Format: I/O7 - I/O0 (Hex); Address Format: A14 - A0 (Hex).
 2. Write Protect state will be activated at end of write even if no other data is loaded.
 3. Write Protect state will be deactivated at end of write period even if no other data is loaded.
 4. 1 to 64 bytes of data are loaded.

21. Software Protected Write Cycle Waveforms⁽¹⁾⁽²⁾

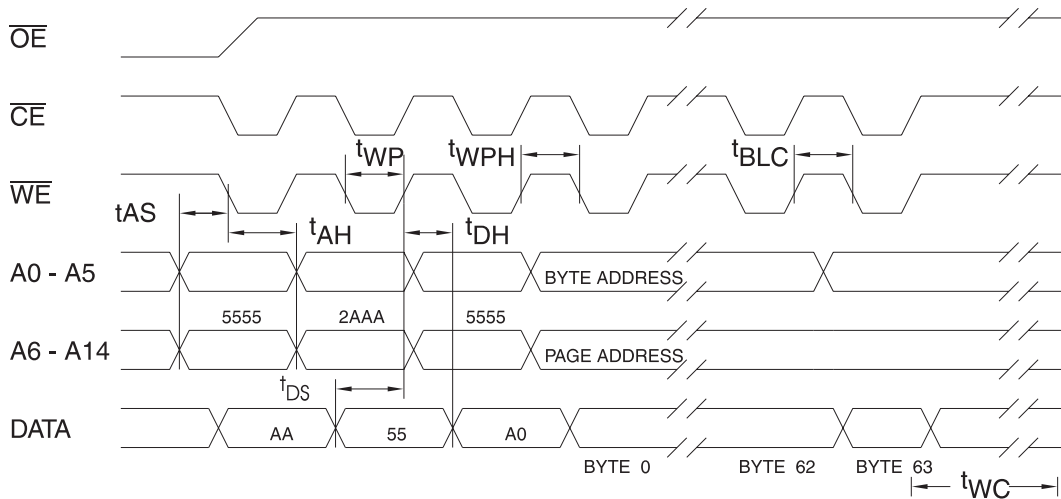

- Notes:
1. A6 through A14 must specify the same page address during each high to low transition of \overline{WE} (or \overline{CE}) after the software code has been entered.
 2. \overline{OE} must be high only when \overline{WE} and \overline{CE} are both low.

22. Data Polling Characteristics⁽¹⁾

Symbol	Parameter	Min	Typ	Max	Units
t_{DH}	Data Hold Time	0			ns
$t_{OE\overline{H}}$	\overline{OE} Hold Time	0			ns
t_{OE}	\overline{OE} to Output Delay ⁽²⁾				ns
t_{WR}	Write Recovery Time	0			ns

- Notes: 1. These parameters are characterized and not 100% tested.
 2. See “AC Read Characteristics” on page 6.

23. Data Polling Waveforms

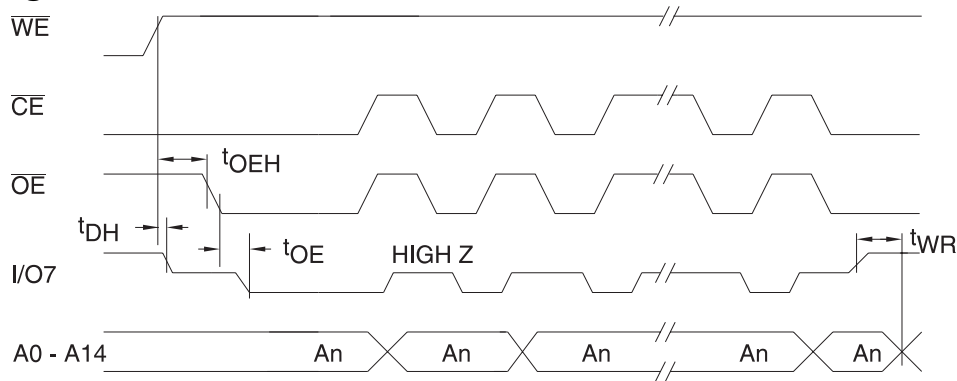

24. Toggle Bit Characteristics⁽¹⁾

Symbol	Parameter	Min	Typ	Max	Units
t_{DH}	Data Hold Time	10			ns
$t_{OE\overline{H}}$	\overline{OE} Hold Time	10			ns
t_{OE}	\overline{OE} to Output Delay ⁽²⁾				ns
t_{OEHP}	\overline{OE} High Pulse	150			ns
t_{WR}	Write Recovery Time	0			ns

- Notes: 1. These parameters are characterized and not 100% tested.
 2. See “AC Read Characteristics” on page 6.

25. Toggle Bit Waveforms⁽¹⁾⁽²⁾⁽³⁾

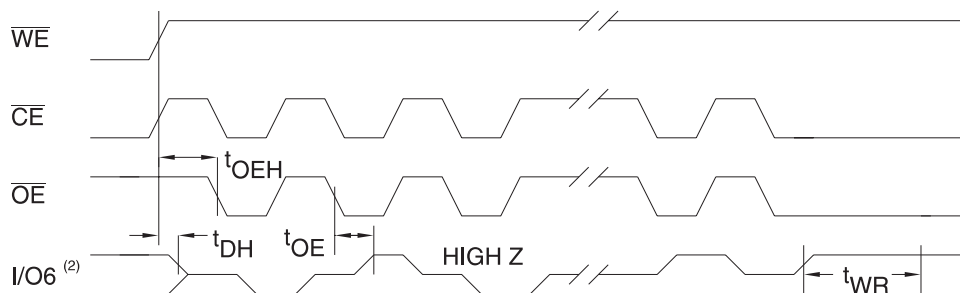

- Notes: 1. Toggling either \overline{OE} or \overline{CE} or both \overline{OE} and \overline{CE} will operate toggle bit.
 2. Beginning and ending state of I/O6 will vary.
 3. Any address location may be used but the address should not vary.

26. Normalized I_{CC} Graphs

NORMALIZED SUPPLY CURRENT vs.
TEMPERATURE

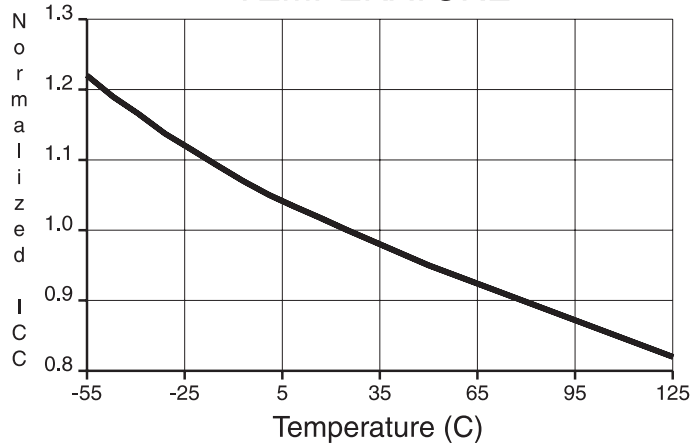

NORMALIZED SUPPLY CURRENT vs.
ADDRESS FREQUENCY

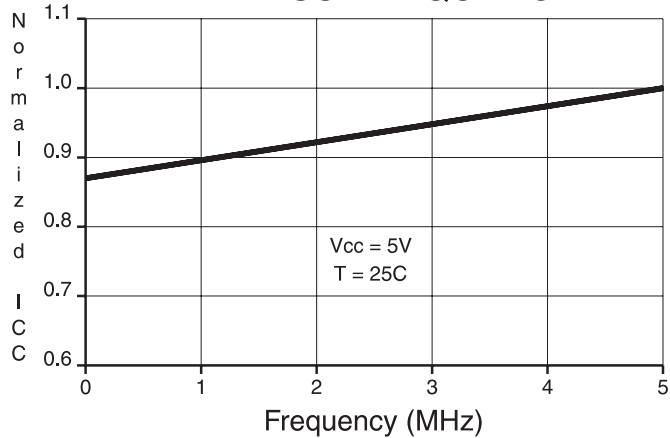

NORMALIZED SUPPLY CURRENT vs.
SUPPLY VOLTAGE

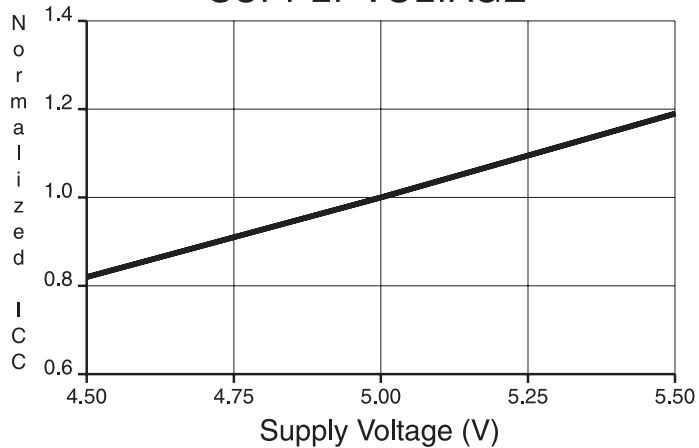

27. Ordering Information⁽²⁾

27.1 Standard Package

t _{Acc} (ns)	I _{cc} (mA)		Ordering Code	Package	Operation Range	
	Active	Standby				
150	50	0.2	AT28C256(E,F)-15JC	32J	Commercial (0°C to 70°C)	
			AT28C256(E,F)-15PC	28P6		
			AT28C256(E,F)-15SC	28S		
			AT28C256(E,F)-15TC	28T		
			AT28C256(E,F)-15JI	32J		Industrial (-40°C to 85°C)
			AT28C256(E,F)-15PI	28P6		
			AT28C256(E,F)-15SI	28S		
			AT28C256(E,F)-15TI	28T		
	50	0.3	AT28C256(E,F)-15DM/883	28D6	Military/883C Class B, Fully Compliant (-55°C to 125°C)	
			AT28C256(E,F)-15FM/883	28F		
			AT28C256(E,F)-15LM/883	32L		
			AT28C256(E,F)-15UM/883	28U		
200	50	0.2	AT28C256(E,F)-20JC	32J	Commercial (0°C to 70°C)	
			AT28C256(E,F)-20PC	28P6		
			AT28C256(E,F)-20SC	28S		
			AT28C256(E,F)-20TC	28T		
			AT28C256(E,F)-20JI	32J		Industrial (-40°C to 85°C)
			AT28C256(E,F)-20PI	28P6		
			AT28C256(E,F)-20SI	28S		
			AT28C256(E,F)-20TI	28T		
	50	0.3	AT28C256(E,F)-20DM/883	28D6	Military/883C Class B, Fully Compliant (-55°C to 125°C)	
			AT28C256(E,F)-20FM/883	28F		
			AT28C256(E,F)-20LM/883	32L		
			AT28C256(E,F)-20UM/883	28U		

Package Type	
28D6	28-lead, 0.600" Wide, Non-windowed, Ceramic Dual Inline Package (Cerdip)
28F	28-lead, Non-windowed, Ceramic Bottom-brazed Flat Package (Flatpack)
32J	32-lead, Plastic J-leaded Chip Carrier (PLCC)
32L	32-pad, Non-windowed, Ceramic Leadless Chip Carrier (LCC)
28P6	28-lead, 0.600" Wide, Plastic Dual Inline Package (PDIP)
28S	28-lead, 0.300" Wide, Plastic Gull Wing Small Outline (SOIC)
28T	28-lead, Plastic Thin Small Outline Package (TSOP)
28U	28-pin, Ceramic Pin Grid Array (PGA)
W	Die
Options	
Blank	Standard Device: Endurance = 10K Write Cycles; Write Time = 10 ms
E	High Endurance Option: Endurance = 100K Write Cycles
F	Fast Write Option: Write Time = 3 ms

27.1 Standard Package (Continued)

t _{Acc} (ns)	I _{CC} (mA)		Ordering Code	Package	Operation Range	
	Active	Standby				
250	50	0.2	AT28C256(E,F)-25JC	32J	Commercial (0°C to 70°C)	
			AT28C256(E,F)-25PC	28P6		
			AT28C256-W	DIE		
	50	0.3	AT28C256(E,F)-25JI	32J	Industrial (-40°C to 85°C)	
			AT28C256(E,F)-25PI	28P6		
			AT28C256(E,F)-25DM/883	28D6		Military/883C Class B, Fully Compliant (-55°C to 125°C)
AT28C256(E,F)-25FM/883	28F					
AT28C256(E,F)-25LM/883	32L					
150 ⁽³⁾	50	0.3	AT28C256(E,F)-25UM/883	28U	Military/883C Class B, Fully Compliant (-55°C to 125°C)	
			AT28C256(E,F)-35UM/883	28U		
			5962-88525 16 UX	28U		Military/883C Class B, Fully Compliant (-55°C to 125°C)
			5962-88525 16 XX	28D6		
			5962-88525 16 YX	32L		
			5962-88525 16 ZX	28F		
	5962-88525 15 UX	28U	Military/883C Class B, Fully Compliant (-55°C to 125°C)			
	5962-88525 15 XX	28D6				
	5962-88525 15 YX	32L				
	5962-88525 15 ZX	28F				
	5962-88525 14 UX	28U	Military/883C Class B, Fully Compliant (-55°C to 125°C)			
	5962-88525 14 XX	28D6				
5962-88525 14 YX	32L					
5962-88525 14 ZX	28F					

Package Type	
28D6	28-lead, 0.600" Wide, Non-windowed, Ceramic Dual Inline Package (Cerdip)
28F	28-lead, Non-windowed, Ceramic Bottom-brazed Flat Package (Flatpack)
32J	32-lead, Plastic J-leaded Chip Carrier (PLCC)
32L	32-pad, Non-windowed, Ceramic Leadless Chip Carrier (LCC)
28P6	28-lead, 0.600" Wide, Plastic Dual Inline Package (PDIP)
28U	28-pin, Ceramic Pin Grid Array (PGA)
W	Die
Options	
Blank	Standard Device: Endurance = 10K Write Cycles; Write Time = 10 ms
E	High Endurance Option: Endurance = 100K Write Cycles
F	Fast Write Option: Write Time = 3 ms

27.1 Standard Package (Continued)

t _{Acc} (ns)	I _{CC} (mA)		Ordering Code	Package	Operation Range	
	Active	Standby				
150 ⁽³⁾	50	0.3	5962-88525 08 UX	28U	Military/883C Class B, Fully Compliant (-55°C to 125°C)	
			5962-88525 08 XX	28D6		
			5962-88525 08 YX	32L		
			5962-88525 08 ZX	28F		
				5962-88525 07 UX	28U	Military/883C Class B, Fully Compliant (-55°C to 125°C)
				5962-88525 07 XX	28D6	
				5962-88525 07 YX	32L	
				5962-88525 07 ZX	28F	
				5962-88525 06 UX	28U	Military/883C Class B, Fully Compliant (-55°C to 125°C)
				5962-88525 06 XX	28D6	
				5962-88525 06 YX	32L	
				5962-88525 06 ZX	28F	
200 ⁽³⁾	50	0.3	5962-88525 12 UX	28U	Military/883C Class B, Fully Compliant (-55°C to 125°C)	
			5962-88525 12 XX	28D6		
			5962-88525 12 YX	32L		
			5962-88525 12 ZX	28F		
	50	0.3		5962-88525 04 UX	28U	Military/883C Class B, Fully Compliant (-55°C to 125°C)
				5962-88525 04 XX	28D6	
				5962-88525 04 YX	32L	
				5962-88525 04 ZX	28F	
250 ⁽³⁾	50	0.3	5962-88525 13 UX	28U	Military/883C Class B, Fully Compliant (-55°C to 125°C)	
			5962-88525 13 XX	28D6		
			5962-88525 13 YX	32L		
			5962-88525 13 ZX	28F		
				5962-88525 11 UX	28U	Military/883C Class B, Fully Compliant (-55°C to 125°C)
				5962-88525 11 XX	28D6	
				5962-88525 11 YX	32L	
				5962-88525 11 ZX	28F	

Package Type	
28D6	28-lead, 0.600" Wide, Non-windowed, Ceramic Dual Inline Package (Cerdip)
28F	28-lead, Non-windowed, Ceramic Bottom-brazed Flat Package (Flatpack)
32L	32-pad, Non-windowed, Ceramic Leadless Chip Carrier (LCC)
28U	28-pin, Ceramic Pin Grid Array (PGA)
W	Die
Options	
Blank	Standard Device: Endurance = 10K Write Cycles; Write Time = 10 ms
E	High Endurance Option: Endurance = 100K Write Cycles
F	Fast Write Option: Write Time = 3 ms

27.1 Standard Package (Continued)

t _{Acc} (ns)	I _{CC} (mA)		Ordering Code	Package	Operation Range
	Active	Standby			
250	50	0.3	5962-88525 05 UX	28U	Military/883C Class B, Fully Compliant (-55°C to 125°C)
			5962-88525 05 XX	28D6	
			5962-88525 05 YX	32L	
			5962-88525 05 ZX	28F	
	5962-88525 03 UX	28U	Military/883C Class B, Fully Compliant (-55°C to 125°C)		
		5962-88525 03 XX		28D6	
		5962-88525 03 YX		32L	
		5962-88525 03 ZX		28F	
300	50	0.3	5962-88525 10 UX	28U	Military/883C Class B, Fully Compliant (-55°C to 125°C)
			5962-88525 10 XX	28D6	
			5962-88525 10 YX	32L	
			5962-88525 10 ZX	28F	
	5962-88525 02 UX	28U	Military/883C Class B, Fully Compliant (-55°C to 125°C)		
		5962-88525 02 XX		28D6	
		5962-88525 02 YX		32L	
		5962-88525 02 ZX		28F	
350	50	0.3	5962-88525 09 UX	28U	Military/883C Class B, Fully Compliant (-55°C to 125°C)
			5962-88525 09 XX	28D6	
			5962-88525 09 YX	32L	
			5962-88525 09 ZX	28F	
	5962-88525 01 UX	28U	Military/883C Class B, Fully Compliant (-55°C to 125°C)		
		5962-88525 01 XX		28D6	
		5962-88525 01 YX		32L	
		5962-88525 01 ZX		28F	

- Notes:
1. Electrical specifications for these speeds are defined by Standard Microcircuit Drawing 5962-88525.
 2. See [“Valid Part Numbers” on page 18](#).
 3. SMD specifies Software Data Protection feature for device type, although Atmel product supplied to every device type in the SMD is 100% tested for this feature.

Package Type	
28D6	28-lead, 0.600" Wide, Non-windowed, Ceramic Dual Inline Package (Cerdip)
28F	28-lead, Non-windowed, Ceramic Bottom-brazed Flat Package (Flatpack)
32L	32-pad, Non-windowed, Ceramic Leadless Chip Carrier (LCC)
28U	28-pin, Ceramic Pin Grid Array (PGA)
W	Die
Options	
Blank	Standard Device: Endurance = 10K Write Cycles; Write Time = 10 ms
E	High Endurance Option: Endurance = 100K Write Cycles
F	Fast Write Option: Write Time = 3 ms

27.2 Green Package Option (Pb/Halide-free)

t_{ACC} (ns)	I_{CC} (mA)		Ordering Code	Package	Operation Range
	Active	Standby			
150	50	0.2	AT28C256(F)-15JU AT28C256(F)-15PU AT28C256(F)-15SU AT28C256(F)-15TU	32J 28P6 28S 28T	Industrial (-40°C to 85°C)

Package Type	
32J	32-lead, Plastic J-leaded Chip Carrier (PLCC)
28P6	28-lead, 0.600" Wide, Plastic Dual Inline Package (PDIP)
28S	28-lead, 0.300" Wide, Plastic Gull Wing Small Outline (SOIC)
28T	28-lead, Plastic Thin Small Outline Package (TSOP)
Options	
Blank	Standard Device: Endurance = 10K Write Cycles; Write Time = 10 ms
F	Fast Write Option: Write Time = 3 ms



28. Valid Part Numbers

The following table lists standard and green Atmel products that can be ordered.

Device Numbers	Speed	Package and Temperature Combinations
AT28C256	15	JC, JI, JU, PC, PI, PU, SC, SI, SU, TC, TI, TU, DM/883, FM/883, LM/883, UM/883
AT28C256E	15	JC, JI, PC, PI, SC, SI, TC, TI, DM/883, FM/883, LM/883, UM/883
AT28C256F	15	JC, JI, JU, PC, PI, PU, SC, SI, SU, TC, TI, TU, DM/883, FM/883, LM/883, UM/883
AT28C256	20	JC, JI, PC, PI, SC, SI, TC, TI, DM/883, FM/883, LM/883, UM/883
AT28C256E	20	JC, JI, PC, PI, SC, SI, TC, TI, DM/883, FM/883, LM/883, UM/883
AT28C256F	20	JC, JI, PC, PI, SC, SI, TC, TI, DM/883, FM/883, LM/883, UM/883
AT28C256	25	JC, JI, PC, PI, SC, SI, TC, TI, DM/883, FM/883, LM/883, UM/883
AT28C256E	25	JC, JI, PC, PI, SC, SI, TC, TI, DM/883, FM/883, LM/883, UM/883
AT28C256F	25	JC, JI, PC, PI, SC, SI, TC, TI, DM/883, FM/883, LM/883, UM/883
AT28C256	–	W

29. Die Products

Reference Section: Parallel EEPROM Die Products

Packaging Information

29.1 28D6 – Cerdip

Dimensions in Millimeters and (Inches).
 Controlling dimension: Inches.
 MIL-STD 1835 D-10 Config A (Glass Sealed)

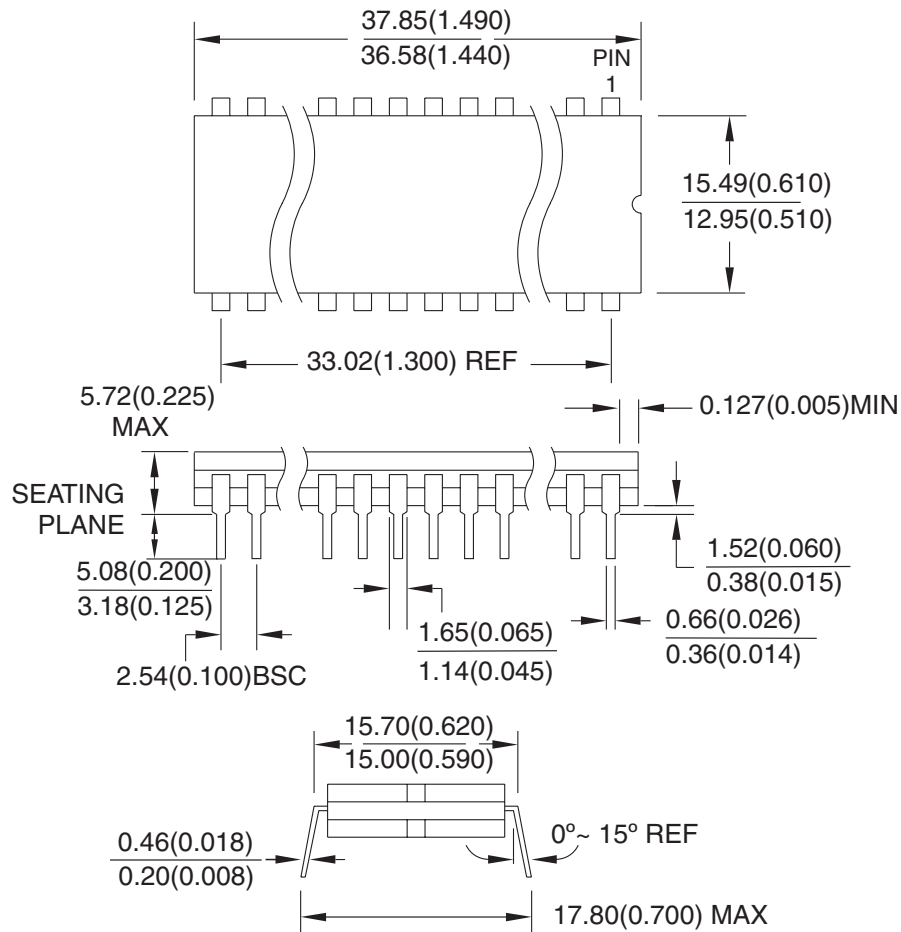

10/23/03



2325 Orchard Parkway
 San Jose, CA 95131

TITLE

28D6, 28-lead, 0.600" Wide, Non-windowed,
 Ceramic Dual Inline Package (Cerdip)

DRAWING NO.

28D6

REV.

B



29.2 28F – Flatpack

Dimensions in Millimeters and (Inches).
 Controlling dimension: Inches.
 MIL-STD 1835 F-12 Config B

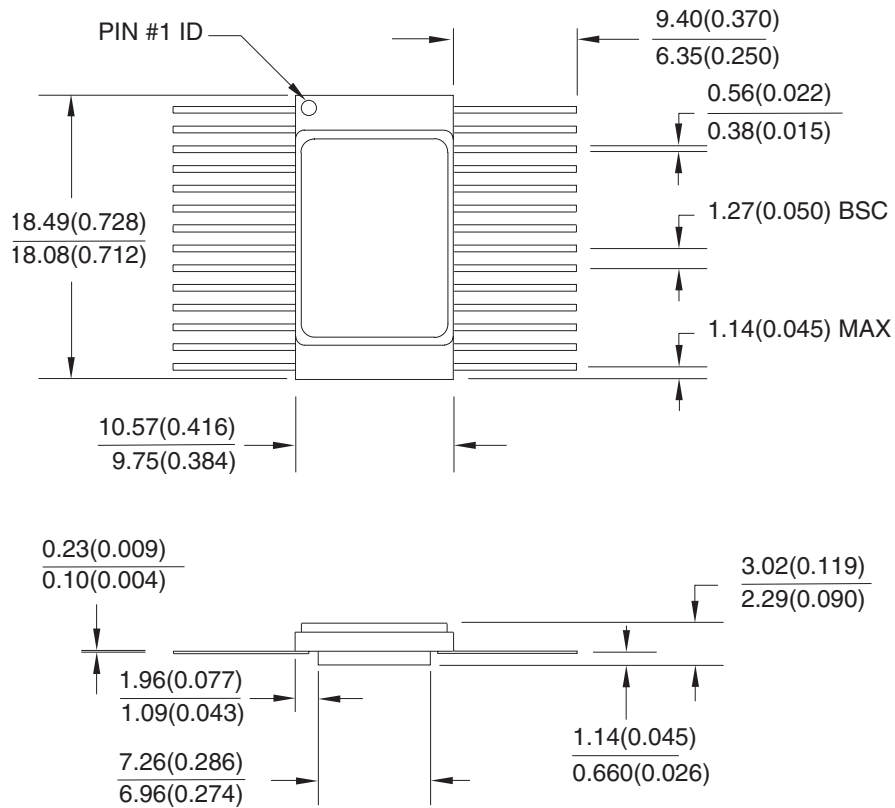

10/21/03



2325 Orchard Parkway
 San Jose, CA 95131

TITLE

28F, 28-lead, Non-windowed, Ceramic Bottom-brazed
 Flat Package (FlatPack)

DRAWING NO.

28F

REV.

B

29.3 32J – PLCC

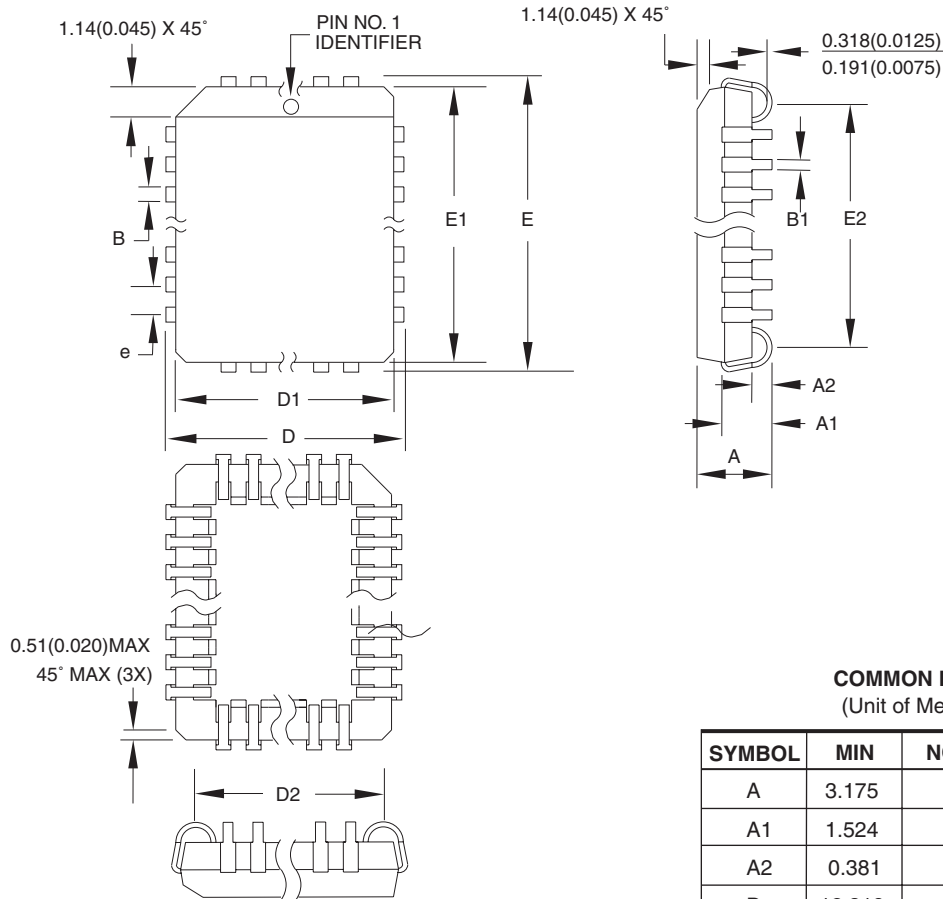

COMMON DIMENSIONS
(Unit of Measure = mm)

SYMBOL	MIN	NOM	MAX	NOTE
A	3.175	–	3.556	
A1	1.524	–	2.413	
A2	0.381	–	–	
D	12.319	–	12.573	
D1	11.354	–	11.506	Note 2
D2	9.906	–	10.922	
E	14.859	–	15.113	
E1	13.894	–	14.046	Note 2
E2	12.471	–	13.487	
B	0.660	–	0.813	
B1	0.330	–	0.533	
e	1.270 TYP			

- Notes:
1. This package conforms to JEDEC reference MS-016, Variation AE.
 2. Dimensions D1 and E1 do not include mold protrusion. Allowable protrusion is .010"(0.254 mm) per side. Dimension D1 and E1 include mold mismatch and are measured at the extreme material condition at the upper or lower parting line.
 3. Lead coplanarity is 0.004" (0.102 mm) maximum.

10/04/01



2325 Orchard Parkway
San Jose, CA 95131

TITLE

32J, 32-lead, Plastic J-leaded Chip Carrier (PLCC)

DRAWING NO.

32J

REV.

B



29.4 32L – LCC

Dimensions in Millimeters and (Inches).
 Controlling dimension: Inches.
 MIL-STD 1835 C-12

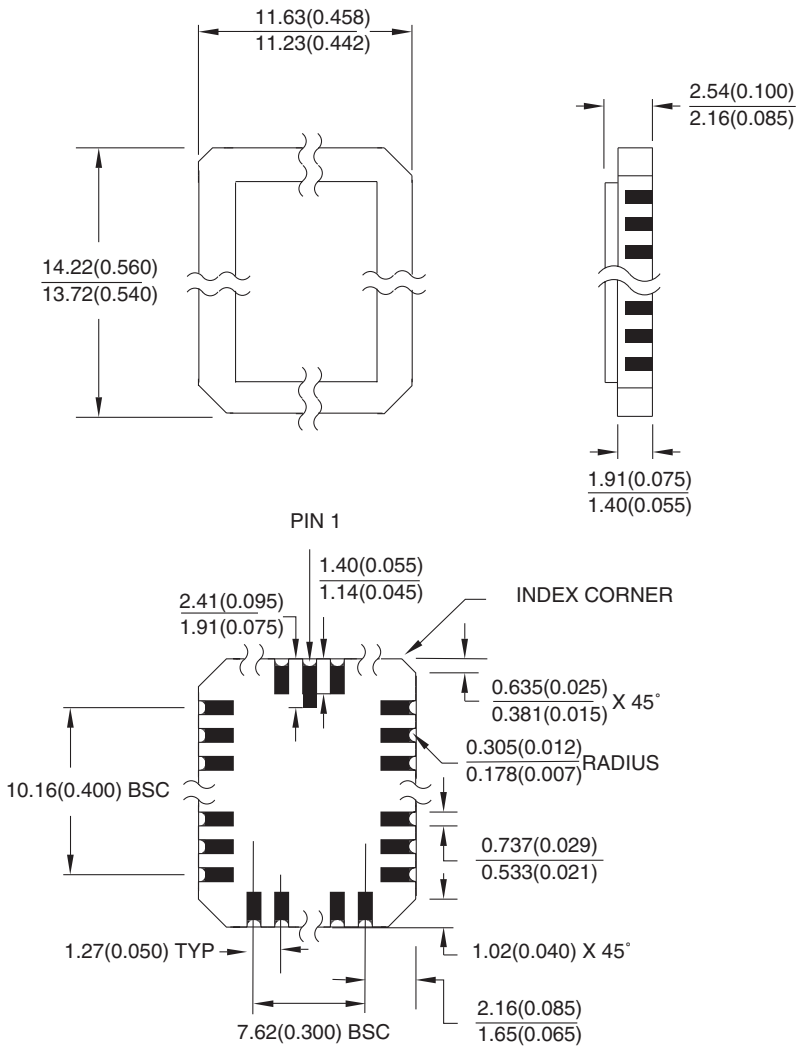

10/21/03



2325 Orchard Parkway
 San Jose, CA 95131

TITLE

32L, 32-pad, Non-windowed, Ceramic Lid, Leadless Chip Carrier (LCC)

DRAWING NO.

32L

REV.

B

29.5 28P6 – PDIP

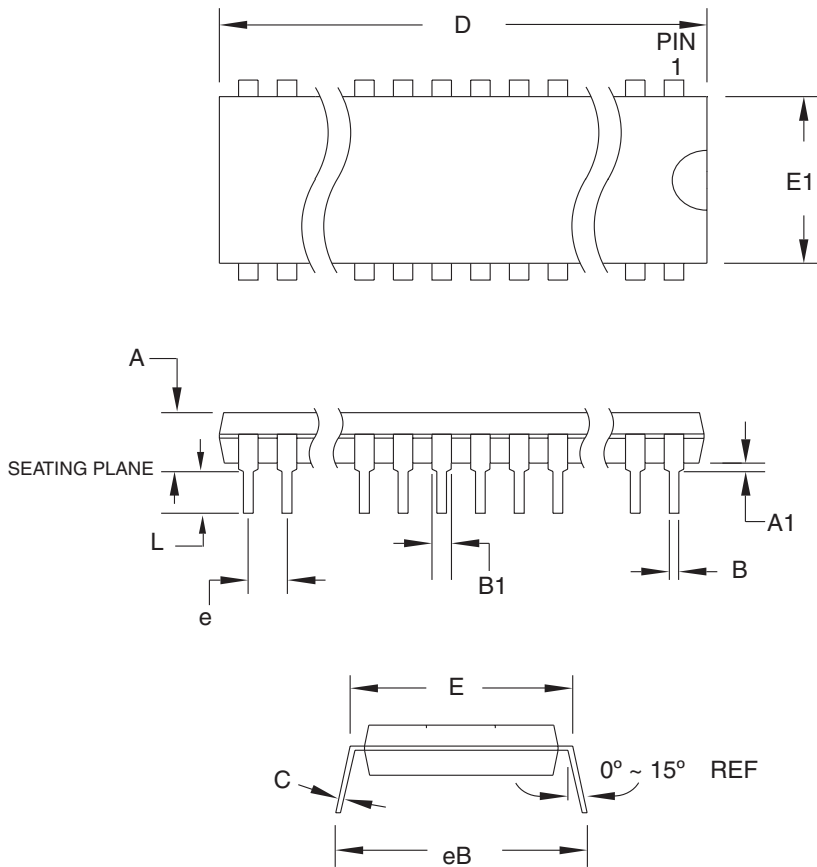

COMMON DIMENSIONS
(Unit of Measure = mm)

SYMBOL	MIN	NOM	MAX	NOTE
A	–	–	4.826	
A1	0.381	–	–	
D	36.703	–	37.338	Note 2
E	15.240	–	15.875	
E1	13.462	–	13.970	Note 2
B	0.356	–	0.559	
B1	1.041	–	1.651	
L	3.048	–	3.556	
C	0.203	–	0.381	
eB	15.494	–	17.526	
e	2.540 TYP			

- Notes: 1. This package conforms to JEDEC reference MS-011, Variation AB.
 2. Dimensions D and E1 do not include mold Flash or Protrusion.
 Mold Flash or Protrusion shall not exceed 0.25 mm (0.010").

09/28/01



2325 Orchard Parkway
San Jose, CA 95131

TITLE

28P6, 28-lead (0.600"/15.24 mm Wide) Plastic Dual
Inline Package (PDIP)

DRAWING NO.

28P6

REV.

B



29.6 28S – SOIC

Dimensions in Millimeters and (Inches).
Controlling dimension: Millimeters.

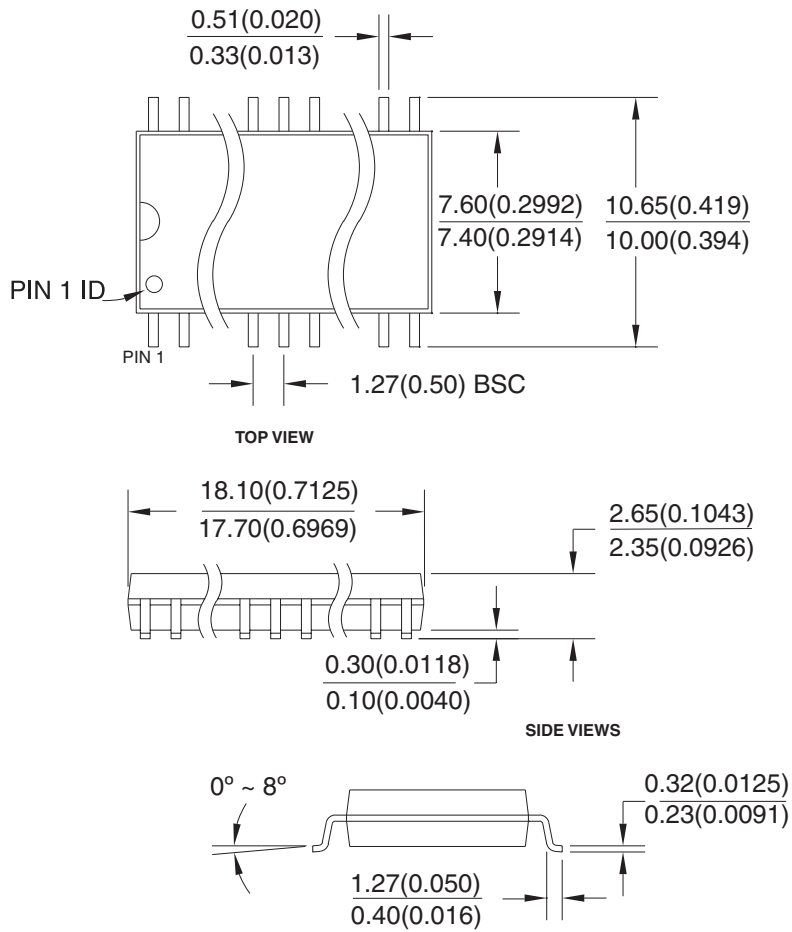

8/4/03



2325 Orchard Parkway
San Jose, CA 95131

TITLE

28S, 28-lead, 0.300" Body, Plastic Gull Wing Small Outline (SOIC)
JEDEC Standard MS-013

DRAWING NO.

28S

REV.

B

29.7 28T – TSOP

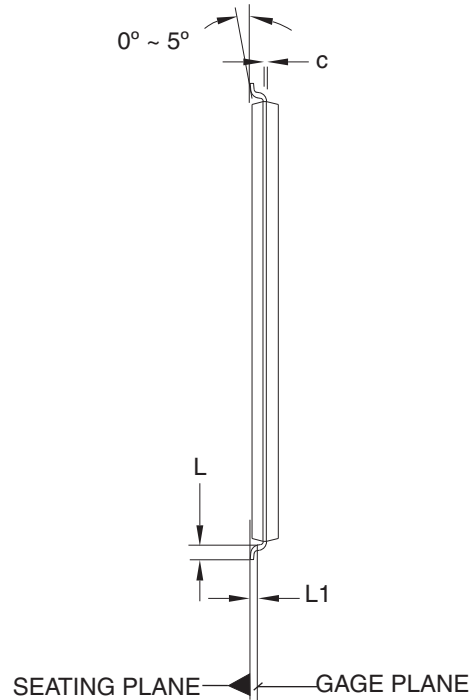
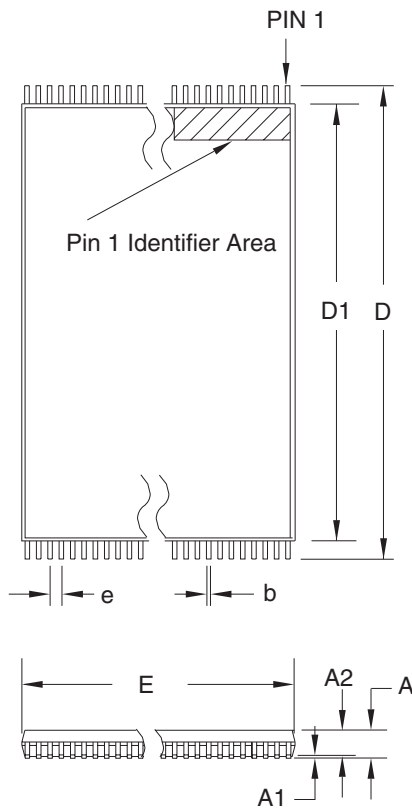

COMMON DIMENSIONS
(Unit of Measure = mm)

SYMBOL	MIN	NOM	MAX	NOTE
A	–	–	1.20	
A1	0.05	–	0.15	
A2	0.90	1.00	1.05	
D	13.20	13.40	13.60	
D1	11.70	11.80	11.90	Note 2
E	7.90	8.00	8.10	Note 2
L	0.50	0.60	0.70	
L1	0.25 BASIC			
b	0.17	0.22	0.27	
c	0.10	–	0.21	
e	0.55 BASIC			

- Notes:
1. This package conforms to JEDEC reference MO-183.
 2. Dimensions D1 and E do not include mold protrusion. Allowable protrusion on E is 0.15 mm per side and on D1 is 0.25 mm per side.
 3. Lead coplanarity is 0.10 mm maximum.

12/06/02



2325 Orchard Parkway
San Jose, CA 95131

TITLE

28T, 28-lead (8 x 13.4 mm) Plastic Thin Small Outline Package, Type I (TSOP)

DRAWING NO.

28T

REV.

C



29.8 28U – PGA

Dimensions in Millimeters and (Inches).
Controlling dimension: Inches.

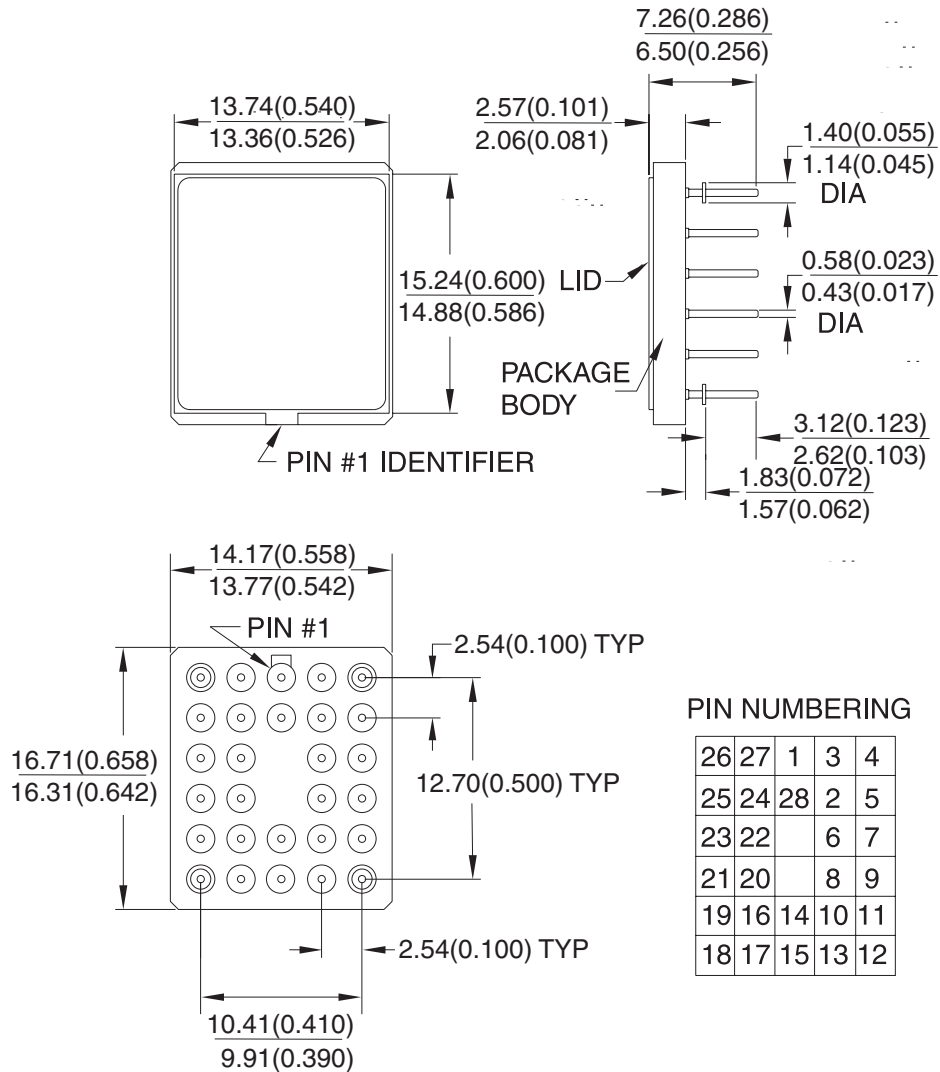

PIN NUMBERING

26	27	1	3	4
25	24	28	2	5
23	22		6	7
21	20		8	9
19	16	14	10	11
18	17	15	13	12

10/21/03



2325 Orchard Parkway
San Jose, CA 95131

TITLE

28U, 28-pin, Ceramic Pin Grid Array (PGA)

DRAWING NO.

28U

REV.

B



Atmel Corporation

2325 Orchard Parkway
San Jose, CA 95131, USA
Tel: 1(408) 441-0311
Fax: 1(408) 487-2600

Regional Headquarters

Europe

Atmel Sarl
Route des Arsenalux 41
Case Postale 80
CH-1705 Fribourg
Switzerland
Tel: (41) 26-426-5555
Fax: (41) 26-426-5500

Asia

Room 1219
Chinachem Golden Plaza
77 Mody Road Tsimshatsui
East Kowloon
Hong Kong
Tel: (852) 2721-9778
Fax: (852) 2722-1369

Japan

9F, Tonetsu Shinkawa Bldg.
1-24-8 Shinkawa
Chuo-ku, Tokyo 104-0033
Japan
Tel: (81) 3-3523-3551
Fax: (81) 3-3523-7581

Atmel Operations

Memory

2325 Orchard Parkway
San Jose, CA 95131, USA
Tel: 1(408) 441-0311
Fax: 1(408) 436-4314

Microcontrollers

2325 Orchard Parkway
San Jose, CA 95131, USA
Tel: 1(408) 441-0311
Fax: 1(408) 436-4314

La Chantrerie
BP 70602
44306 Nantes Cedex 3, France
Tel: (33) 2-40-18-18-18
Fax: (33) 2-40-18-19-60

ASIC/ASSP/Smart Cards

Zone Industrielle
13106 Rousset Cedex, France
Tel: (33) 4-42-53-60-00
Fax: (33) 4-42-53-60-01

1150 East Cheyenne Mtn. Blvd.
Colorado Springs, CO 80906, USA
Tel: 1(719) 576-3300
Fax: 1(719) 540-1759

Scottish Enterprise Technology Park
Maxwell Building
East Kilbride G75 0QR, Scotland
Tel: (44) 1355-803-000
Fax: (44) 1355-242-743

RF/Automotive

Theresienstrasse 2
Postfach 3535
74025 Heilbronn, Germany
Tel: (49) 71-31-67-0
Fax: (49) 71-31-67-2340

1150 East Cheyenne Mtn. Blvd.
Colorado Springs, CO 80906, USA
Tel: 1(719) 576-3300
Fax: 1(719) 540-1759

Biometrics/Imaging/Hi-Rel MPU/ High Speed Converters/RF Datacom

Avenue de Rochepleine
BP 123
38521 Saint-Egreve Cedex, France
Tel: (33) 4-76-58-30-00
Fax: (33) 4-76-58-34-80

Literature Requests

www.atmel.com/literature

Disclaimer: The information in this document is provided in connection with Atmel products. No license, express or implied, by estoppel or otherwise, to any intellectual property right is granted by this document or in connection with the sale of Atmel products. **EXCEPT AS SET FORTH IN ATMEL'S TERMS AND CONDITIONS OF SALE LOCATED ON ATMEL'S WEB SITE, ATMEL ASSUMES NO LIABILITY WHATSOEVER AND DISCLAIMS ANY EXPRESS, IMPLIED OR STATUTORY WARRANTY RELATING TO ITS PRODUCTS INCLUDING, BUT NOT LIMITED TO, THE IMPLIED WARRANTY OF MERCHANTABILITY, FITNESS FOR A PARTICULAR PURPOSE, OR NON-INFRINGEMENT. IN NO EVENT SHALL ATMEL BE LIABLE FOR ANY DIRECT, INDIRECT, CONSEQUENTIAL, PUNITIVE, SPECIAL OR INCIDENTAL DAMAGES (INCLUDING, WITHOUT LIMITATION, DAMAGES FOR LOSS OF PROFITS, BUSINESS INTERRUPTION, OR LOSS OF INFORMATION) ARISING OUT OF THE USE OR INABILITY TO USE THIS DOCUMENT, EVEN IF ATMEL HAS BEEN ADVISED OF THE POSSIBILITY OF SUCH DAMAGES.** Atmel makes no representations or warranties with respect to the accuracy or completeness of the contents of this document and reserves the right to make changes to specifications and product descriptions at any time without notice. Atmel does not make any commitment to update the information contained herein. Atmel's products are not intended, authorized, or warranted for use as components in applications intended to support or sustain life.

© Atmel Corporation 2005. All rights reserved. Atmel®, logo and combinations thereof, and others, are registered trademarks, and Everywhere You AreSM and others are the trademarks of Atmel Corporation or its subsidiaries. Other terms and product names may be trademarks of others.



Printed on recycled paper.

0006I-PEEPR-4/05