

KBPC10, 15,25,35 SERIES

HIGH CURRENT SINGLE - PHASE SILICON BRIDGE RECTIFIERS

FEATURES



KBPC STANDARD

- ◆ This series is UL recognized under component index, file number E54214
- ◆ The plastic material used carries Underwriters Laboratory flammability recognition 94V-O
- ◆ Integrally molded heatsink provide very low thermal resistance for maximum heat dissipation
- ◆ Universal 4-way terminals; snap-on, wrap -around, solder or P.C. board mounting
- ◆ Surge overload ratings to 400 Amperes
- ◆ Terminals solderable per MIL-STD-202, Method 208
- ◆ Typical I_R less than 0.1 μ A
- ◆ High temperature soldering guaranteed: 250° C /10 seconds / .375", (9.5mm) lead length / 5lbs., (2.3 kg) tension



KBPC-W WIRE LEADS

- Case:** Molded plastic with heatsink integrally mounted in the bridge encapsulation
- Terminals:** Either plated .25" (6.35mm). Faston or plated copper leads .040" (1.02mm) diameter. Suffix letter "W" added to indicate leads
- Weight:** .706 ounce, 20 gram
- Mounting Position:** Bolt down on heat-sink with silicone thermal compound between bridge and mounting surface for maximum heat transfer efficiency
- Mounting Torque:** 20 in. lb. max.
- Polarity:** Polarity symbols molded on body

MECHANICAL DATA

MAXIMUM RATINGS AND ELECTRICAL CHARACTERISTICS

Ratings at 25°C ambient temperature unless otherwise specified . 60 Hz, resistive or inductive load. For capacitive load, derate current by 20%.

		-005 -01 -02 -04 -06 -08 -10								
Maximum Recurrent Peak Reverse Voltage		V _{RRM}	50	100	200	400	600	800	1000	Volts
Maximum RMS Voltage		V _{RMS}	35	70	140	280	420	560	700	Volts
Maximum DC Blocking Voltage		V _{DC}	50	100	200	400	600	800	1000	Volts
Maximum Average Forward Rectified Output Current at at T _c = 55°C	KBPC10 KBPC15 KBPC25 KBPC35	I _(AV)				10.0 15.0 25.0 35.0				Amps
Peak Forward Surge Current Single sine-wave superimposed on rated load (JEDEC Method)	KBPC10 KBPC15 KBPC25 KBPC35	I _{FSM}				200 300 300 400				Amps
Rating (non-repetitive, for t greater than 1 ms and less than 8.3 ms) for Fusing	KBPC10 KBPC15 KBPC25 KBPC35	i ² t				160 375 375 660				A ² s
Maximum Instantaneous Forward Voltage drop per element at specified current	KBPC10 5.0A KBPC15 7.5A KBPC25 12.5A KBPC35 17.5A	V _F				1.2				Volts
Isolation Voltage from case to leads						2500				V _{ac}
Maximum Reverse DC Current at Rated DC Blocking Voltage per element		I _R				10.0				μ A
Typical Thermal Resistance (Note 1)		R θ JC				2.0				°C/W
Operating and Storage Temperature Range,		T _J , T _{STG}				-50 to +150				°C

NOTES: 1. Thermal Resistance from Junction to Case.

RATINGS AND CHARACTERISTIC CURVES KBPC10,15,25,35 SERIES

FIG. 1

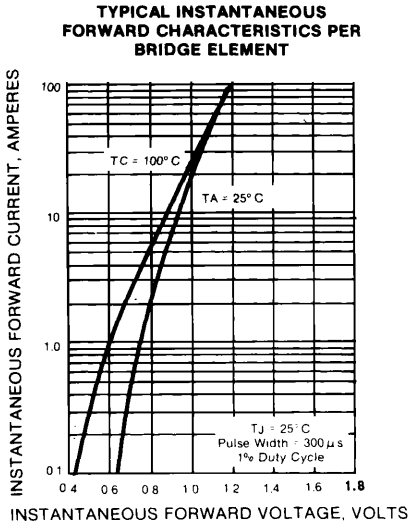

FIG. 2

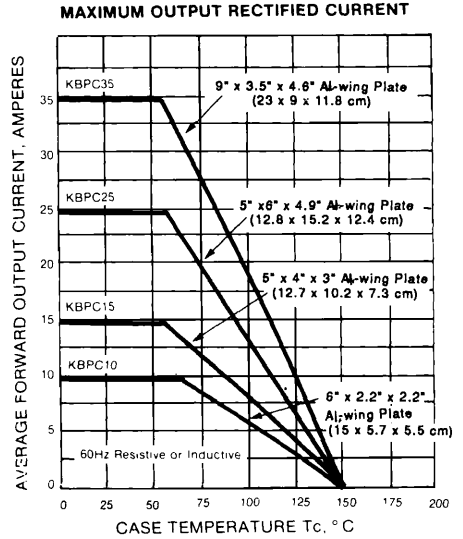

FIG. 3

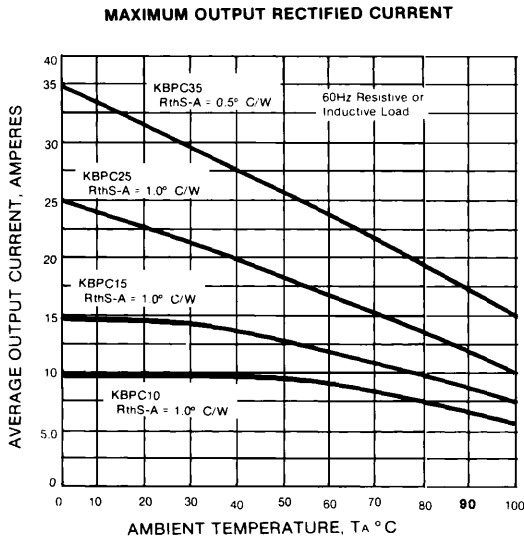
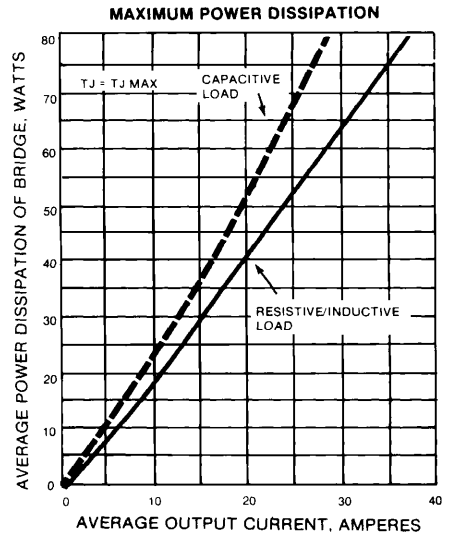

FIG. 4



RATINGS AND CHARACTERISTIC CURVES KBPC 10,15,25,35 SERIES

FIG. 5

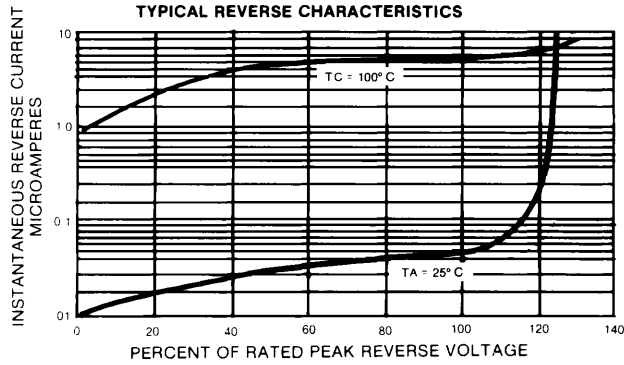

FIG. 6

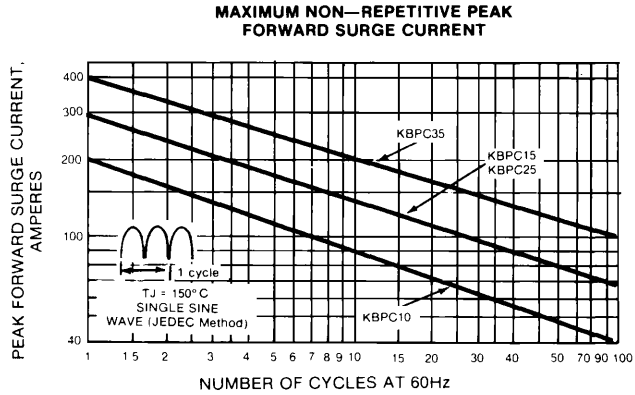
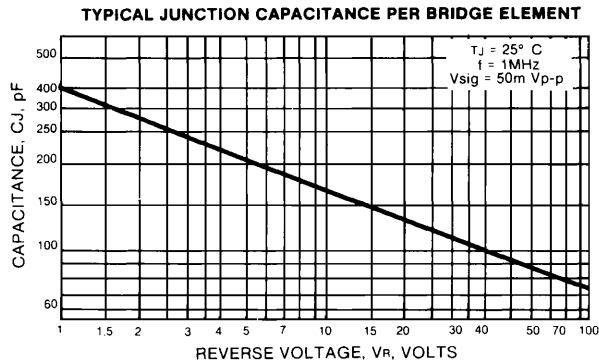
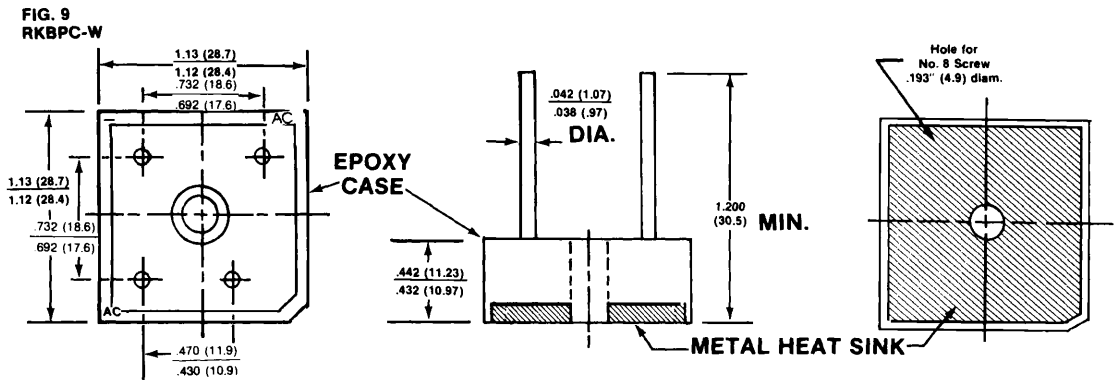
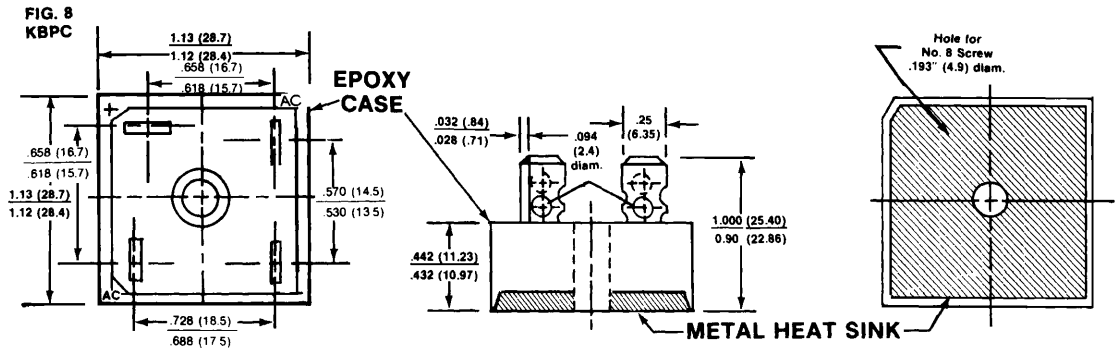

FIG. 7





NOTES:

1. Corrosion resistant terminals designed for .250 female quick connector, wrap around or solder.
 2. A thin film of silicone thermal compound is recommended between the bridge case and mounting surface for improved thermal conduction.
 3. Higher dielectric strengths available. Consult factory.
 4. These bridges are also available in fast recovery and in positive and negative center tap and in doubler configurations. Consult Factory.
- Dimensions in inches and (millimeters).