



8K x 8 Registered Diagnostic PROM

Features

- CMOS for optimum speed/power
- High speed (commercial and military)
 - 15-ns address set-up
 - 12-ns clock to output
- Low power
 - 660 mW (commercial)
 - 770 mW (military)
- On-chip edge-triggered registers
 - Ideal for pipelined microprogrammed systems

- On-chip diagnostic shift register
 - For serial observability and controllability of the output register
- EPROM technology
 - 100% programmable
 - Reprogrammable (7C269W)
- 5V ± 10% V_{CC}, commercial and military
- Capable of withstanding >2001V static discharge
- Slim 300-mil, 28-pin plastic or hermetic DIP

Functional Description

The CY7C269 is a 8K x 8 registered diagnostic PROM. It is organized as 8,192 words by 8 bits wide, and has both a pipeline output register and an onboard diagnostic shift register. The device features a programmable initialize byte that may be loaded into the pipeline register with the initialize signal. The programmable initialize byte is the 8,193rd byte in the PROM, and may be programmed to any desired value.

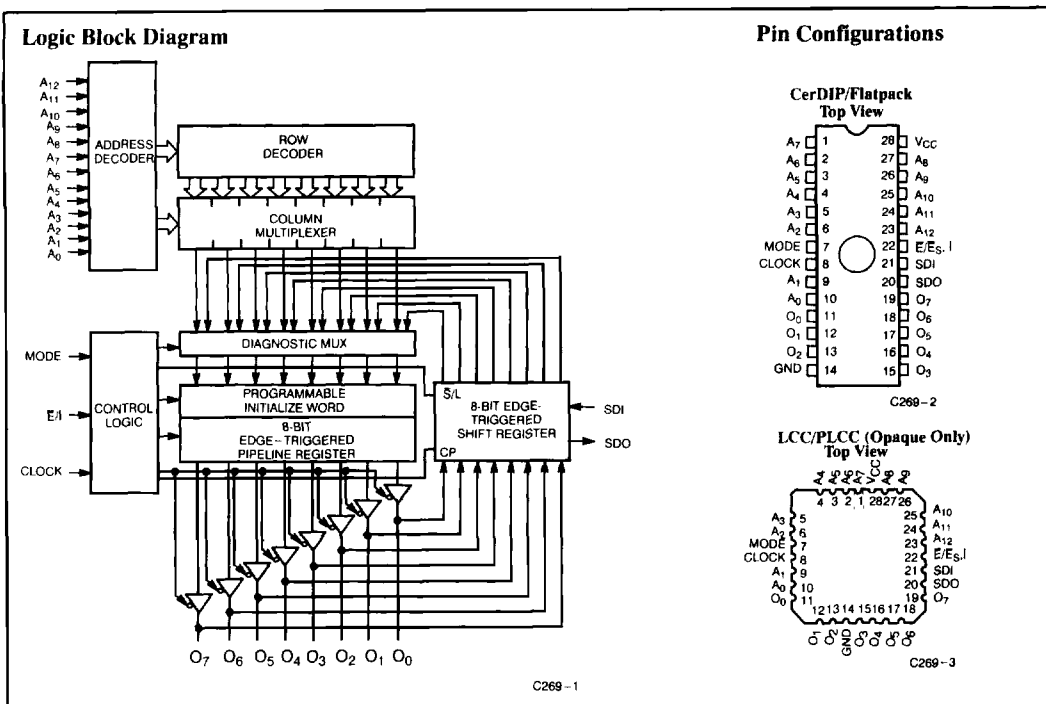

Selection Guide

		7C269-15	7C269-25	7C269-40	7C269-50
Minimum Address Set-Up Time (ns)		15	25	40	50
Maximum Clock to Output (ns)		12	15	20	25
Maximum Operating Current (mA)	Commercial	120	120	100	80
	Military	140	140		120

Functional Description (continued)

The CY7C269 is optimized for applications that require diagnostics in a minimum amount of board area. Packaged in 28 pins, it has 13 address signals (A₀ through A₁₂), 8 data out signals (O₀ through O₇), \bar{E}/\bar{I} (Enable or Initialize), and CLOCK (pipeline and diagnostic clock). Additional diagnostic signals consist of MODE, SDI (shift in), and SDO (shift out). Normal pipelined operation and diagnostic operation are mutually exclusive.

When the MODE signal is LOW, the 7C269 operates in a normal pipelined mode. CLOCK functions as a pipeline clock, loading the contents of the addressed memory location into the pipeline register on each rising edge. The data will appear on the outputs if they are enabled. One pin on the 7C269 is programmed to perform either the Enable or the Initialize function. If the \bar{E}/\bar{I} pin is used for a $\bar{I}NIT$ (asynchronous initialize) function, the outputs are permanently enabled and the initialize word is loaded into the pipeline register on a HIGH to LOW transition of the $\bar{I}NIT$ signal. The $\bar{I}NIT$ LOW disables CLOCK and must return high to re-enable CLOCK. If the \bar{E}/\bar{I} pin is used for an enable signal, it may be programmed for either synchronous or asynchronous operation.

Maximum Ratings

(Above which the useful life may be impaired. For user guidelines, not tested.)

Storage Temperature	-65°C to +150°C
Ambient Temperature with Power Applied	-55°C to +125°C
Supply Voltage to Ground Potential	-0.5V to +7.0V
DC Voltage Applied to Outputs in High Z State	-0.5V to +7.0V
DC Input Voltage	-3.0V to +7.0V
DC Program Voltage	13.0V
UV Exposure	7258 Wsec/cm ²
Static Discharge Voltage (per MIL-STD-883, Method 3015)	>2001V

When the MODE signal is HIGH, the 7C269 operates in the diagnostic mode. The \bar{E}/\bar{I} signal becomes a secondary mode signal designating whether to shift the diagnostic shift register or to load either the diagnostic register or the pipeline register. If \bar{E}/\bar{I} is HIGH, it shifts SDI into the least-significant location of the diagnostic register and all bits one location toward the most-significant location on each rising edge. The contents of the most-significant location in the diagnostic register are available on the SDO pin.

If the \bar{E}/\bar{I} signal is LOW, SDI becomes a direction signal, transferring the contents of the diagnostic register into the pipeline register when SDI is LOW. When SDI is HIGH, the contents of the output pins are transferred into the diagnostic register. Both transfers occur on a LOW to HIGH transition of the CLOCK. If the outputs are enabled, the contents of the pipeline register are transferred into the diagnostic register. If the outputs are disabled, an external source of data may be loaded into the diagnostic register. In this condition, the SDO signal is internally driven to be the same as the SDI signal, thus propagating the "direction of transfer information" to the next device in the string.

Latch-Up Current >200 mA

Operating Range

Range	Ambient Temperature	V _{CC}
Commercial	0°C to +70°C	5V ± 10%
Industrial ^[1]	-40°C to +85°C	5V ± 10%
Military ^[2]	-55°C to +125°C	5V ± 10%

Notes:

- Contact a Cypress representative for industrial temperature range specifications.
- T_A is the "instant on" case temperature.

Electrical Characteristics Over the Operating Range^[3, 4]

Parameter	Description	Test Conditions	7C269-15, 25		7C269-40		7C269-50		Unit
			Min.	Max.	Min.	Max.	Min.	Max.	
V _{OH}	Output HIGH Voltage	V _{CC} = Min., I _{OH} = -2.0 mA	2.4						V
		V _{CC} = Min., I _{OH} = -4.0 mA			2.4		2.4		V
V _{OL}	Output LOW Voltage	V _{CC} = Min., I _{OL} = 8.0 mA	Com'l	0.4					V
		V _{CC} = Min., I _{OL} = 6.0 mA	Mil	0.4					
		V _{CC} = Min., I _{OL} = 12.0 mA	Com'l				0.4	0.4	V
		V _{CC} = Min., I _{OL} = 8.0 mA	Mil				0.4	0.4	
V _{IH}	Input HIGH Voltage		2.0		2.0		2.0	V	
V _{IL}	Input LOW Voltage			0.8		0.8		0.8	V
I _{IX}	Input Load Current	GND ≤ V _{IN} ≤ V _{CC}	-10	+10	-10	+10	-10	+10	μA
I _{OZ}	Output Leakage Current	GND ≤ V _{OUT} ≤ V _{CC} , Output Disabled	-40	+40	-40	+40	-40	+40	μA
I _{OS} ^[5]	Output Short Circuit Current			90		90		90	mA
I _{CC}	V _{CC} Operating Supply Current	V _{CC} = Max., I _{OUT} = 0 mA	Com'l	120		100		80	mA
			Mil	140				120	
V _{PP}	Programming Supply Voltage		12	13	12	13	12	13	V
I _{PP}	Programming Supply Current			50		50		50	mA
V _{IHP}	Input HIGH Programming Voltage		3.0		3.0		3.0		V
V _{ILP}	Input LOW Programming Voltage			0.4		0.4		0.4	V

Capacitance^[4, 6]

Parameter	Description	Test Conditions	Max.	Unit
C _{IN}	Input Capacitance	T _A = 25°C, f = 1 MHz, V _{CC} = 5.0V	10	pF
C _{OUT}	Output Capacitance		10	pF

Notes:

- See the last page of this specification for Group A subgroup testing information.
- See Introduction to CMOS PROMs in this Data Book for general information on testing.
- For test purposes, not more than one output at a time should be shorted. Short circuit test duration should not exceed 30 seconds.
- Tested initially and after any design or process changes that may affect these parameters.

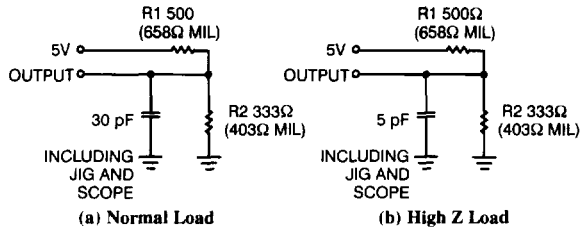
AC Test Loads and Waveforms
Test Load for -15 through -25 speeds

C269-4

C269-5

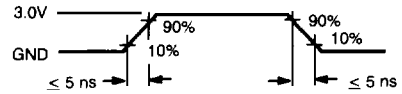

Equivalent to: THÉVENIN EQUIVALENT

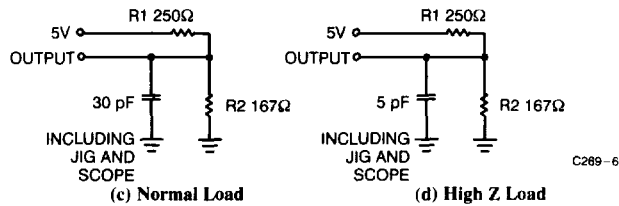
Test Load for -40 through -50 speeds

C269-6

Equivalent to: THÉVENIN EQUIVALENT



Switching Characteristics Over the Operating Range^[3, 4]

Parameter	Description	7C269-15		7C269-25		7C269-40		7C269-50		Unit
		Min.	Max.	Min.	Max.	Min.	Max.	Min.	Max.	
t_{AS}	Address Set-Up to Clock	15		25		40		50		ns
t_{AH}	Address Hold from Clock	0		0		0		0		ns
t_{CO}	Clock to Output Valid		12		15		20		25	ns
t_{PWC}	Clock Pulse Width	12		15		15		20		ns
t_{SES}	\bar{E}_S Set-Up to Clock (Sync Enable Only)	12		15		15		15		ns
t_{HES}	\bar{E}_S Hold from Clock	5		5		5		5		ns
t_{DI}	\overline{INIT} to Out Valid		15		18		25		35	ns
t_{RI}	\overline{INIT} Recovery to Clock	12		15		20		25		ns
t_{PWI}	\overline{INIT} Pulse Width	12		15		25		35		ns
t_{COS}	Output Valid from Clock (Sync. Mode)		12		15		20		25	ns
t_{HZC}	Output Inactive from Clock (Sync. Mode)		12		15		20		25	ns
t_{DOE}	Output Valid from \bar{E} LOW (Async. Mode)		12		15		20		25	ns
t_{HZE}	Output Inactive from \bar{E} HIGH (Async. Mode)		12		15		20		25	ns

Diagnostic Mode Switching Characteristics Over the Operating Range^[3, 4]

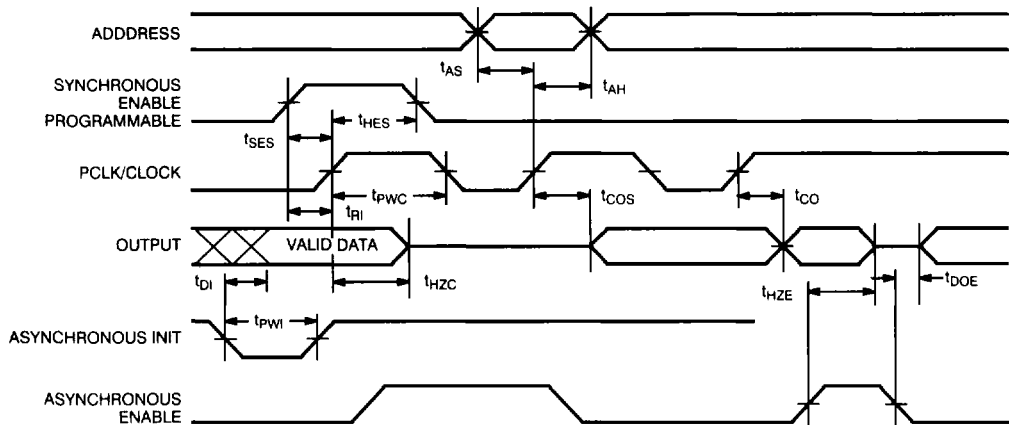
Parameter	Description		7C269-15		7C269-25		7C269-40,50		Unit
			Min.	Max.	Min.	Max.	Min.	Max.	
t _{SSDI}	Set-Up SDI to Clock	Com'l	20		25		30		ns
		Mil	25		30		35		
t _{HSDI}	SDI Hold from Clock	Com'l	0		0		0		ns
		Mil	0		0		0		
t _{DSDO}	SDO Delay from Clock	Com'l		20		25		30	ns
		Mil		25		30		40	
t _{DCL}	Minimum Clock LOW	Com'l	20		25		25		ns
		Mil	25		25		25		
t _{DCH}	Minimum Clock HIGH	Com'l	20		25		25		ns
		Mil	25		25		25		
t _{SM}	Set-Up to Mode Change	Com'l	20		25		25		ns
		Mil	25		30		30		
t _{HM}	Hold from Mode Change	Com'l	0		0		0		ns
		Mil	0		0		0		
t _{MS}	Mode to SDO	Com'l		20		25		25	ns
		Mil		25		30		30	
t _{SS}	SDI to SDO	Com'l		30		40		40	ns
		Mil		35		40		45	
t _{SO}	Data Set-Up to DCLK	Com'l	20		25		25		ns
		Mil	25		30		30		
t _{HO}	Data Hold from DCLK	Com'l	10		10		10		ns
		Mil	13		13		15		

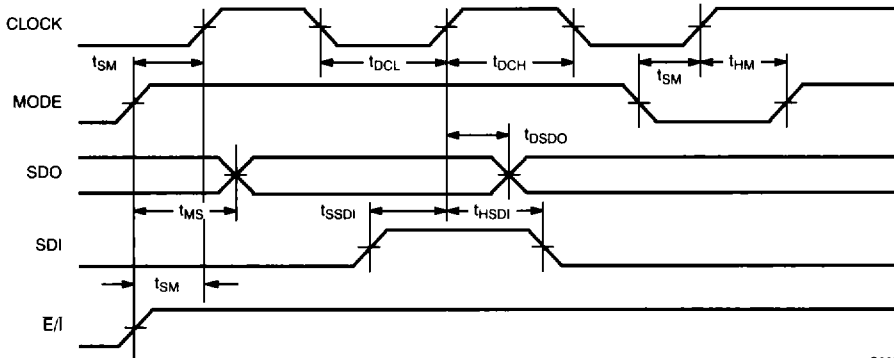
Switching Waveforms^[3, 4]
Pipeline Operation (Mode = 0)

Switching Waveforms^[3,4] (continued)
Diagnostic Application (Shifting the Shadow Register^[7])

C269-8

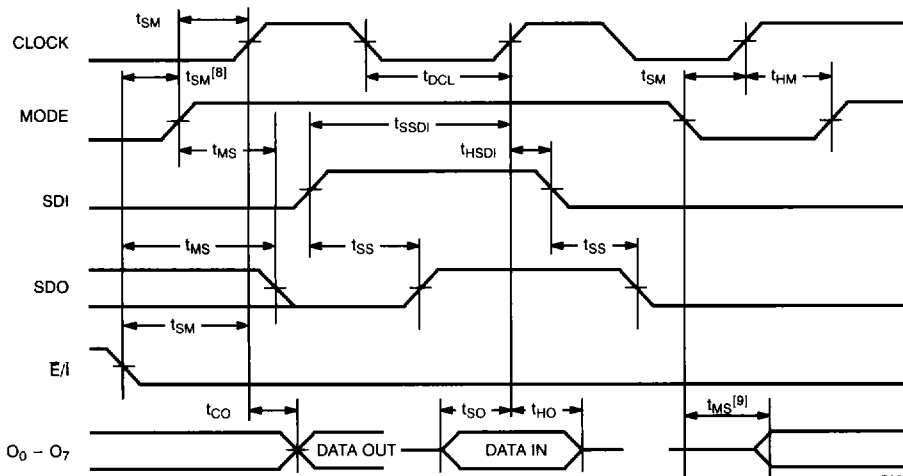
Diagnostic Application (Parallel Data Transfer)

C269-9

Notes:

7. Diagnostic register = shadow register = shift register.
 8. Asynchronous enable mode only.

9. The mode transition to HIGH latches the asynchronous enable state. If the enable state is changed and held before leaving the diagnostic mode (mode H \rightarrow L) then the output impedance change delay is t_{MS} .

Bit Map Data

Programmer Address (Hex.)		RAM Data
Decimal	Hex	Contents
0	0	Data
.	.	.
8191	1FFF	Data
8192	2000	Init Byte
8193	2001	Control Byte

Control Byte

- 00 Asynchronous output enable (default condition)
- 01 Synchronous output enable
- 02 Asynchronous initialize

Programming Modes

Programming support is available from Cypress as well as from a number of third-party software vendors. For detailed programming information, including a listing of software packages, please see the PROM Programming Information located at the end of this section. Programming algorithms can be obtained from any Cypress representative.

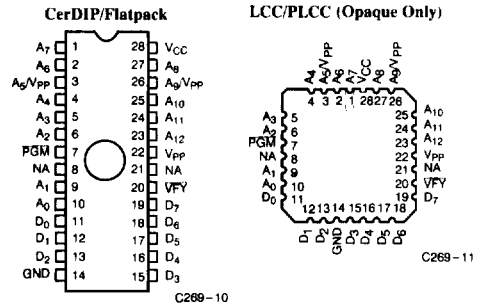
Figure 1. Programming Pinouts

Mode Selection

Mode	Pin Function ^[10]								
	Read or Output Disable	A ₁₂	A ₁₁	A ₁₀ - A ₇	A ₆	A ₅	A ₄ - A ₃	A ₂	A ₁
	Other	A ₁₂	A ₁₁	A ₁₀ - A ₇	A ₆	A ₅	A ₄ - A ₃	A ₂	A ₁
Read		A ₁₂	A ₁₁	A ₁₀ - A ₇	A ₆	A ₅	A ₄ - A ₃	A ₂	A ₁
Load SR to PR		A ₁₂	A ₁₁	A ₁₀ - A ₇	A ₆	A ₅	A ₄ - A ₃	A ₂	A ₁
Load Output to SR		A ₁₂	A ₁₁	A ₁₀ - A ₇	A ₆	A ₅	A ₄ - A ₃	A ₂	A ₁
Shift SR		A ₁₂	A ₁₁	A ₁₀ - A ₇	A ₆	A ₅	A ₄ - A ₃	A ₂	A ₁
Asynchronous Enable Read		A ₁₂	A ₁₁	A ₁₀ - A ₇	A ₆	A ₅	A ₄ - A ₃	A ₂	A ₁
Synchronous Enable Read		A ₁₂	A ₁₁	A ₁₀ - A ₇	A ₆	A ₅	A ₄ - A ₃	A ₂	A ₁
Asynchronous Initialization Read		A ₁₂	A ₁₁	A ₁₀ - A ₇	A ₆	A ₅	A ₄ - A ₃	A ₂	A ₁
Program Memory		A ₁₂	A ₁₁	A ₁₀ - A ₇	A ₆	A ₅	A ₄ - A ₃	A ₂	A ₁
Program Verify		A ₁₂	A ₁₁	A ₁₀ - A ₇	A ₆	A ₅	A ₄ - A ₃	A ₂	A ₁
Program Inhibit		A ₁₂	A ₁₁	A ₁₀ - A ₇	A ₆	A ₅	A ₄ - A ₃	A ₂	A ₁
Program Synchronous Enable		V _{IHP}	V _{IHP}	A ₁₀ - A ₇	V _{IHP}	V _{PP}	A ₄ - A ₃	V _{IHP}	A ₁
Program Initialize		V _{ILP}	V _{IHP}	A ₁₀ - A ₇	V _{IHP}	V _{PP}	A ₄ - A ₃	V _{ILP}	A ₁
Program Initial Byte		A ₁₂	V _{ILP}	A ₁₀ - A ₇	V _{IHP}	V _{PP}	A ₄ - A ₃	V _{ILP}	A ₁

Mode	Pin Function ^[10]							
	Read or Output Disable	A ₀	MODE	CLK	SDI	SDO	E, I	O ₇ - O ₀
	Other	A ₀	PGM	CLK	NA	V _{VFY}	V _{PP}	D ₇ - D ₀
Read		A ₀	V _{IL}	V _{IL} /V _{IH}	X	High Z	V _{IL}	O ₇ - O ₀
Load SR to PR		A ₀	V _{IH}	V _{IL} /V _{IH}	V _{IL}	SDI	V _{IL}	O ₇ - O ₀
Load Output to SR		A ₀	V _{IH}	V _{IL} /V _{IH}	V _{IH}	SDI	V _{IL}	O ₇ - O ₀
Shift SR		A ₀	V _{IH}	V _{IL} /V _{IH}	D _{IN}	SDO	V _{IH}	O ₇ - O ₀
Asynchronous Enable Read		A ₀	V _{IL}	V _{IL}	X	High Z	V _{IL}	O ₇ - O ₀
Synchronous Enable Read		A ₀	V _{IL}	V _{IL} /V _{IH}	X	High Z	V _{IL}	O ₇ - O ₀
Asynchronous Initialization Read		A ₀	V _{IL}	V _{IL}	X	High Z	V _{IL}	O ₇ - O ₀
Program Memory		A ₀	V _{ILP}	V _{ILP}	X	V _{IHP}	V _{PP}	D ₇ - D ₀
Program Verify		A ₀	V _{IHP}	V _{ILP}	X	V _{ILP}	V _{PP}	O ₇ - O ₀
Program Inhibit		A ₀	V _{IHP}	V _{ILP}	X	V _{IHP}	V _{PP}	High Z
Program Synchronous Enable		V _{ILP}	V _{ILP}	V _{ILP}	X	V _{IHP}	V _{PP}	D ₇ - D ₀
Program Initialize		V _{ILP}	V _{ILP}	V _{ILP}	X	V _{IHP}	V _{PP}	D ₇ - D ₀
Program Initial Byte		V _{IHP}	V _{ILP}	V _{ILP}	X	V _{IHP}	V _{PP}	D ₇ - D ₀

Note:

 10. X = "don't care" but not to exceed V_{CC} ± 5%.

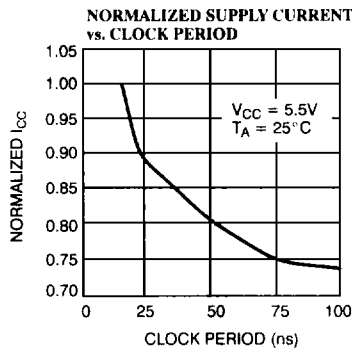
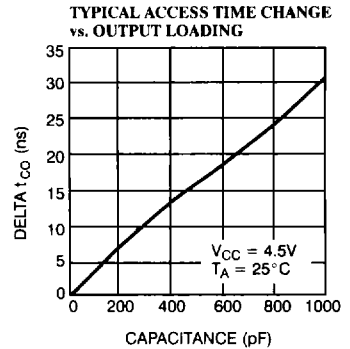
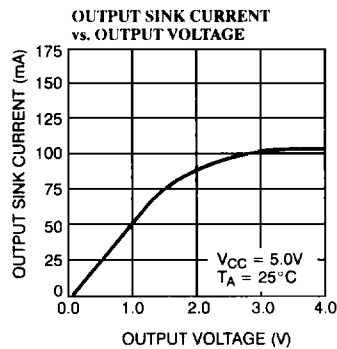
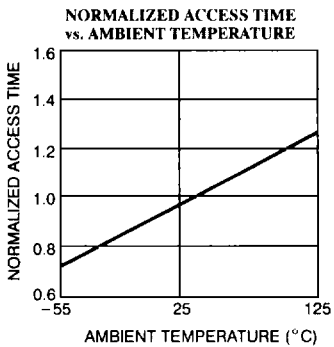
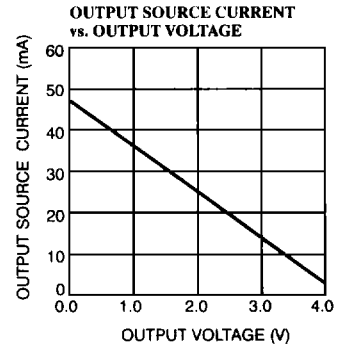
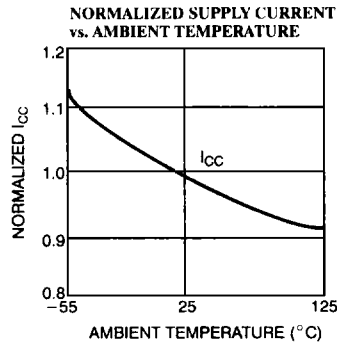
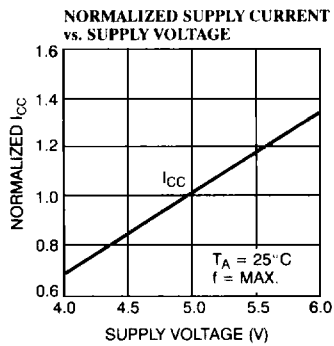
Typical DC and AC Characteristics

Ordering Information⁽¹⁾

Speed (ns)	I _{CC} (mA)	Ordering Code	Package Name	Package Type	Operating Range
15	120	CY7C269-15JC	J64	28-Lead Plastic Leaded Chip Carrier	Commercial
		CY7C269-15PC	P21	28-Lead (300-Mil) Molded DIP	
		CY7C269-15WC	W22	28-Lead (300-Mil) Windowed CerDIP	
	140	CY7C269-15DMB	D22	28-Lead (300-Mil) CerDIP	Military
		CY7C269-15LMB	L64	28-Square Leadless Chip Carrier	
		CY7C269-15QMB	Q64	28-Pin Windowed Leadless Chip Carrier	
CY7C269-15WMB		W22	28-Lead (300-Mil) Windowed CerDIP		
25	140	CY7C269-25JC	J64	28-Lead Plastic Leaded Chip Carrier	Commercial
		CY7C269-25PC	P21	28-Lead (300-Mil) Molded DIP	
		CY7C269-25WC	W22	28-Lead (300-Mil) Windowed CerDIP	
		CY7C269-25DMB	D22	28-Lead (300-Mil) CerDIP	Military
		CY7C269-25LMB	L64	28-Square Leadless Chip Carrier	
		CY7C269-25QMB	Q64	28-Pin Windowed Leadless Chip Carrier	
40	100	CY7C269-40JC	J64	28-Lead Plastic Leaded Chip Carrier	Commercial
		CY7C269-40PC	P21	28-Lead (300-Mil) Molded DIP	
		CY7C269-40WC	W22	28-Lead (300-Mil) Windowed CerDIP	
50	80	CY7C269-50JC	J64	28-Lead Plastic Leaded Chip Carrier	Commercial
		CY7C269-50PC	P21	28-Lead (300-Mil) Molded DIP	
		CY7C269-50WC	W22	28-Lead (300-Mil) Windowed CerDIP	
	120	CY7C269-50DMB	D22	28-Lead (300-Mil) CerDIP	Military
		CY7C269-50LMB	L64	28-Square Leadless Chip Carrier	
		CY7C269-50QMB	Q64	28-Pin Windowed Leadless Chip Carrier	
		CY7C269-50WMB	W22	28-Lead (300-Mil) Windowed CerDIP	

Note:

11. Most of these products are available in industrial temperature range. Contact a Cypress representative for specifications and product availability.

**MILITARY SPECIFICATIONS**
Group A Subgroup Testing**DC Characteristics**

Parameters	Subgroups
V _{OH}	1, 2, 3
V _{OL}	1, 2, 3
V _{IH}	1, 2, 3
V _{IL}	1, 2, 3
I _{IX}	1, 2, 3
I _{OZ}	1, 2, 3
I _{CC}	1, 2, 3
I _{SB}	1, 2, 3

Switching Characteristics

Parameters	Subgroups
t _{AS}	7, 8, 9, 10, 11
t _{HA}	7, 8, 9, 10, 11
t _{CO}	7, 8, 9, 10, 11
t _{PW}	7, 8, 9, 10, 11
t _{SES}	7, 8, 9, 10, 11
t _{HES}	7, 8, 9, 10, 11
t _{COS}	7, 8, 9, 10, 11

Diagnostic Mode Switching Characteristics

Parameters	Subgroups
t _{SSDI}	7, 8, 9, 10, 11
t _{HSDI}	7, 8, 9, 10, 11
t _{DSDO}	7, 8, 9, 10, 11
t _{DCL}	7, 8, 9, 10, 11
t _{DCH}	7, 8, 9, 10, 11
t _{HM}	7, 8, 9, 10, 11
t _{MS}	7, 8, 9, 10, 11
t _{SS}	7, 8, 9, 10, 11

Document #: 38-00069-G