



ARM Cortex™-M0
32-BIT MICROCONTROLLER

NuMicro™ Family
M052/M054 Data Sheet

TABLE OF CONTENTS

1	GENERAL DESCRIPTION	6
2	FEATURES	7
3	BLOCK DIAGRAM	11
4	SELECTION TABLE	12
5	PIN CONFIGURATION	13
5.1	QFN 33 pin	13
5.2	LQFP 48 pin	14
5.3	Pin Description	15
6	FUNCTIONAL DESCRIPTION	18
6.1	ARM® Cortex™-M0 Core	18
6.2	System Manager	20
6.2.1	Overview	20
6.2.2	System Reset	20
6.2.3	System Power Architecture	20
6.2.4	System Timer (SysTick)	21
6.2.5	Nested Vectored Interrupt Controller (NVIC)	22
6.3	Clock Controller	26
6.3.1	Overview	26
6.3.2	Clock Generator Block Diagram	26
6.3.3	System Clock & SysTick Clock	27
6.3.4	AHB Clock Source Select	28
6.3.5	Peripherals Clock Source Select	28
6.3.6	Power Down Mode (Deep Sleep Mode) Clock	29
6.3.7	Frequency Divider Output	30
6.4	General Purpose I/O	32
6.4.1	Overview	32
6.5	I2C Serial Interface Controller (Master/Slave)	34
6.5.1	Overview	34
6.5.2	Features	34
6.6	PWM Generator and Capture Timer	36
6.6.1	Overview	36
6.6.2	Features	37
6.7	Serial Peripheral Interface (SPI) Controller	38
6.7.1	Overview	38
6.7.2	Features	38
6.8	Timer Controller	39
6.8.1	Overview	39
6.8.2	Features:	39

6.9 Watchdog Timer (WDT).....	40
6.9.1 Overview.....	40
6.9.2 Features.....	41
6.10 UART Interface Controller.....	42
6.10.1 Overview.....	42
6.10.2 Features.....	44
6.11 Analog-to-Digital Converter (ADC).....	45
6.11.1 Overview.....	45
6.11.2 Features.....	45
6.12 External Bus Interface (EBI).....	47
6.12.1 Overview.....	47
6.12.2 Features.....	47
6.13 Flash Memory Controller (FMC).....	48
6.13.1 Overview.....	48
6.13.2 Features.....	48
7 TYPICAL APPLICATION CIRCUIT.....	49
8 ELECTRICAL CHARACTERISTICS.....	50
8.1 Absolute Maximum Ratings.....	50
8.2 DC Electrical Characteristics.....	51
8.3 AC Electrical Characteristics.....	54
8.3.1 External Crystal.....	54
8.3.2 External Oscillator.....	54
8.3.3 Typical Crystal Application Circuits.....	54
8.3.4 Internal 22.1184 MHz RC Oscillator.....	55
8.3.5 Internal 10kHz RC Oscillator.....	55
8.4 Analog Characteristics.....	56
8.4.1 Specification of 600kHz sps 12-bit SARADC.....	56
8.4.2 Specification of LDO & Power management.....	56
8.4.3 Specification of Low Voltage Reset.....	57
8.4.4 Specification of Brownout Detector.....	57
8.4.5 Specification of Power-On Reset (5V).....	58
8.5 SPI Dynamic characteristics.....	59
9 PACKAGE DIMENSIONS.....	61
9.1 LQFP-48 (7x7x1.4mm ² Footprint 2.0mm).....	61
9.2 QFN-33 (5X5 mm ² , Thickness 0.8mm, Pitch 0.5 mm).....	62
10 REVISION HISTORY.....	63

LIST OF FIGURES

Figure 3–1 NuMicro™ M051 Series Block Diagram	11
Figure 4–1 NuMicro™ Naming Rule	12
Figure 5–1 NuMicro™ M051 Series QFN33 Pin Diagram	13
Figure 5–2 NuMicro™ M051 Series LQFP-48 Pin Diagram	14
Figure 6–1 Functional Block Diagram	18
Figure 6–2 NuMicro M051™ Series Power Architecture Diagram.....	21
Figure 6–3 Clock generator block diagram	26
Figure 6–4 System Clock Block Diagram	27
Figure 6–5 SysTick clock Control Block Diagram	27
Figure 6–6 AHB Clock Source for HCLK	28
Figure 6–7 Peripherals Clock Source Select for PCLK.....	29
Figure 6–8 Clock Source of Frequency Divider	30
Figure 6–9 Block Diagram of Frequency Divider	31
Figure 6–10 Push-Pull Output.....	32
Figure 6–11 Open-Drain Output.....	33
Figure 6–12 Quasi-bidirectional I/O Mode	33
Figure 6–13 I2C Bus Timing	34
Figure 6–14 Timing of Interrupt and Reset Signal	41
Figure 8–1 Typical Crystal Application Circuit	55
Figure 8–2 SPI Master timing.....	60
Figure 8–3 SPI Slave timing.....	60

LIST OF TABLES

Table 4–1 NuMicro™ M051 Series Product Selection Guide.....	12
Table 5–1 NuMicro™ M051 Series Pin Description	17
Table 6–1 Exception Model.....	24
Table 6–2 System Interrupt Map.....	24
Table 6–3 Vector Table Format	25
Table 6–4 Watchdog Timeout Interval Selection	40
Table 6–5 UART Baud Rate Equation	42
Table 6–6 UART Baud Rate Setting Table	43

1 GENERAL DESCRIPTION

The NuMicro M051™ series is a 32-bit microcontroller with embedded ARM® Cortex™-M0 core for industrial control and applications which need rich communication interfaces. The Cortex™-M0 is the newest ARM embedded processor with 32-bit performance and at a cost equivalent to traditional 8-bit microcontroller. The NuMicro M051™ series includes M052, M054, M058 and M0516 families.

The M052/M054 can run up to 50 MHz. Thus it can afford to support a variety of industrial control and applications which need high CPU performance. The M052/M054 has 8K/16K-byte embedded flash, 4K-byte data flash, 4K-byte flash for the ISP, and 4K-byte embedded SRAM.

Many system level peripheral functions, such as I/O Port, EBI (External Bus Interface), Timer, UART, SPI, I2C, PWM, ADC, Watchdog Timer and Brownout Detector, have been incorporated into the M052/M054 in order to reduce component count, board space and system cost. These useful functions make the M052/M054 powerful for a wide range of applications.

Additionally, the M052/M054 is equipped with ISP (In-System Programming) and ICP (In-Circuit Programming) functions, which allow the user to update the program memory without removing the chip from the actual end product.

2 FEATURES

- Core
 - ARM® Cortex™ -M0 core runs up to 50 MHz.
 - One 24-bit system timer.
 - Supports low power sleep-mode.
 - A single-cycle 32-bit hardware multiplier.
 - NVIC for the 32 interrupt inputs, each with 4-levels of priority.
 - Supports Serial Wire Debug (SWD) interface and 2 watchpoints/4 breakpoints.
- Built-in LDO for Wide Operating Voltage Range: 2.5V to 5.5V
- Memory
 - 8KB/16KB Flash memory for program memory (APROM)
 - 4KB Flash memory for data memory (DataFlash)
 - 4KB Flash memory for loader (LDRAM)
 - 4KB SRAM for internal scratch-pad RAM (SRAM)
- Clock Control
 - Programmable system clock source
 - 4~24 MHz external crystal input
 - 22.1184 MHz internal oscillator (trimmed to 1% accuracy)
 - 10 kHz low-power oscillator for Watchdog Timer and wake-up in sleep mode
 - PLL allows CPU operation up to the maximum 50MHz
- I/O Port
 - Up to 40 general-purpose I/O (GPIO) pins for LQFP-48 package
 - Four I/O modes:
 - ◆ Quasi bi-direction



- ◆ Push-Pull output
- ◆ Open-Drain output
- ◆ Input only with high impedance
- TTL/Schmitt trigger input selectable
- I/O pin can be configured as interrupt source with edge/level setting
- Supports high driver and high sink IO mode
- Timer
 - Provides four channel 32-bit timers, one 8-bit pre-scale counter with 24-bit up-timer for each timer.
 - Independent clock source for each timer.
 - 24-bit timer value is readable through TDR (Timer Data Register)
 - Provides one-shot, periodic and toggle operation modes.
- Watchdog Timer
 - Multiple clock sources
 - Supports wake up from power down or sleep mode
 - Interrupt or reset selectable on watchdog time-out
- PWM
 - Built-in up to four 16-bit PWM generators; providing eight PWM outputs or four complementary paired PWM outputs
 - Individual clock source, clock divider, 8-bit pre-scalar and dead-zone generator for each PWM generator
 - PWM interrupt synchronized to PWM period
 - 16-bit digital Capture timers (shared with PWM timers) with rising/falling capture inputs
 - Supports capture interrupt
- UART
 - Up to two sets of UART device



- Programmable baud-rate generator
- Buffered receiver and transmitter, each with 15 bytes FIFO
- Optional flow control function (CTS and RTS)
- Supports IrDA(SIR) function
- Supports RS485 function
- SPI
 - Up to two sets of SPI device.
 - Supports master/slave mode
 - Master mode clock rate up to 20 MHz, and slave mode clock rate up to 10 MHz
 - Full duplex synchronous serial data transfer
 - Variable length of transfer data from 1 to 32 bits
 - MSB or LSB first data transfer
 - Rx latching data can be either at rising edge or at falling edge of serial clock
 - Tx sending data can be either at rising edge or at falling edge of serial clock
 - Supports Byte suspend mode in 32-bit transmission
- I2C
 - Supports master/slave mode
 - Bidirectional data transfer between masters and slaves
 - Multi-master bus (no central master).
 - Arbitration between simultaneously transmitting masters without corruption of serial data on the bus
 - Serial clock synchronization allows devices with different bit rates to communicate via one serial bus.
 - Serial clock synchronization can be used as a handshake mechanism to suspend and resume serial transfer.
 - Programmable clocks allow versatile rate control.

- Supports multiple address recognition (four slave address with mask option)
- ADC
 - 12-bit SAR ADC with 600k SPS
 - Up to 8-ch single-ended input or 4-ch differential input
 - Supports single mode/burst mode/single-cycle scan mode/continuous scan mode
 - Each channel with an individual result register
 - Supports conversion value monitoring (or comparison) for threshold voltage detection
 - Conversion can be started either by software trigger or external pin trigger
- EBI (External Bus Interface) for external memory-mapped device access
 - Accessible space: 64KB in 8-bit mode or 128KB in 16-bit mode
 - Supports 8-bit/16-bit data width
- In-System Programming (ISP) and In-Circuit Programming (ICP)
- Brownout Detector
 - With 4 levels: 4.5V/3.8V/2.7V/2.2V
 - Supports brownout interrupt and reset option
- LVR (Low Voltage Reset)
 - Threshold voltage levels: 2.0V
- Operating Temperature: -40°C~85°C
- Packages:
 - Green package (RoHS)
 - 48-pin LQFP, 33-pin QFN

3 BLOCK DIAGRAM

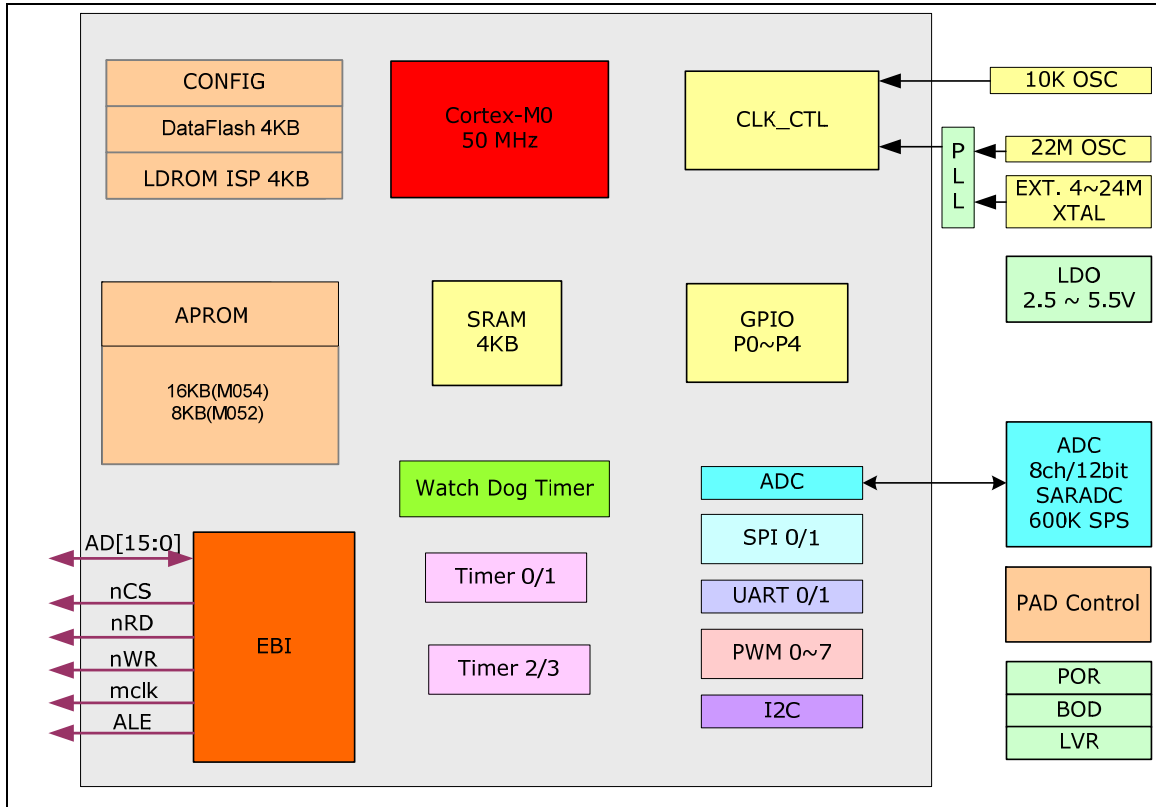

Figure 3–1 NuMicro™ M051 Series Block Diagram

4 SELECTION TABLE

NuMicro M051™ Series Selection Guide

Part No.	APROM	RAM	Data Flash	LDROM	I/O	Timer	Connectivity			PWM	ADC	EBI	ISP ICP	Package
							UART	SPI	I2C					
M052LAN	8KB	4KB	4KB	4KB	40	4x32-bit	2	2	1	8	8x12-bit	v	v	LQFP48
M052ZAN	8KB	4KB	4KB	4KB	24	4x32-bit	2	1	1	5	5x12-bit		v	QFN 33
M054LAN	16KB	4KB	4KB	4KB	40	4x32-bit	2	2	1	8	8x12-bit	v	v	LQFP48
M054ZAN	16KB	4KB	4KB	4KB	24	4x32-bit	2	1	1	5	5x12-bit		v	QFN 33

Table 4–1 NuMicro™ M051 Series Product Selection Guide

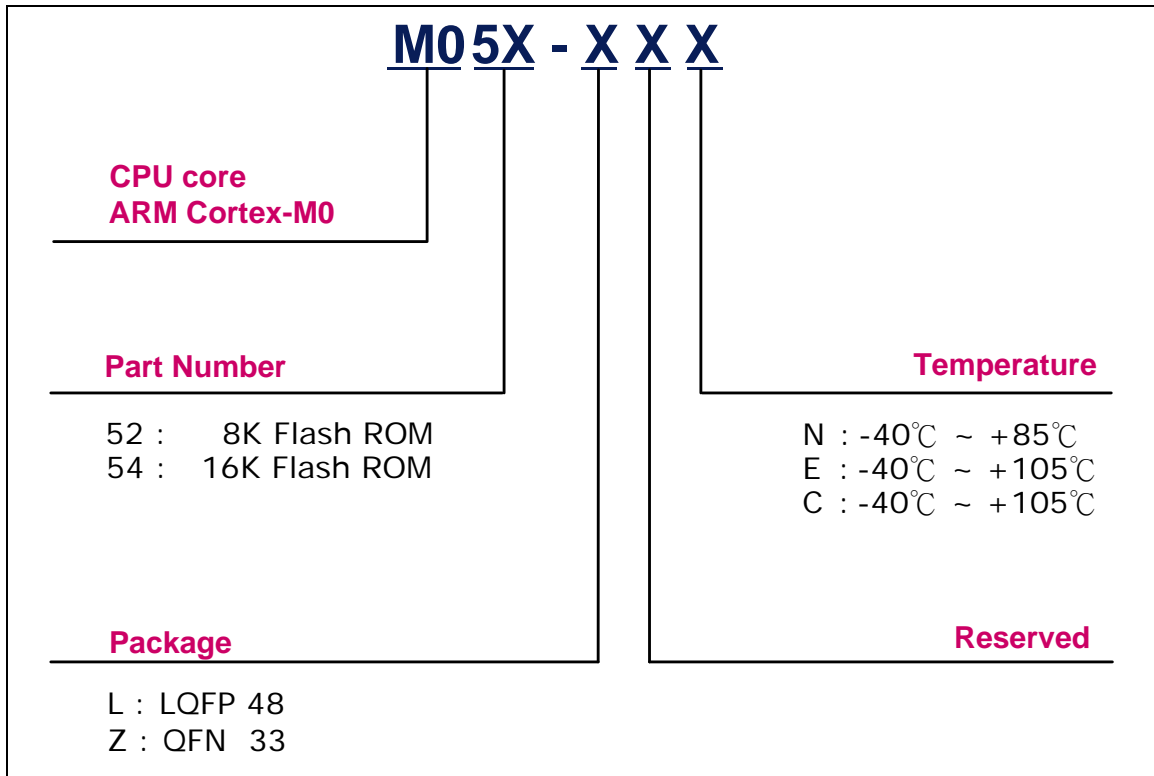

Figure 4–1 NuMicro M051™ Naming Rule

5 PIN CONFIGURATION

5.1 QFN 33 pin

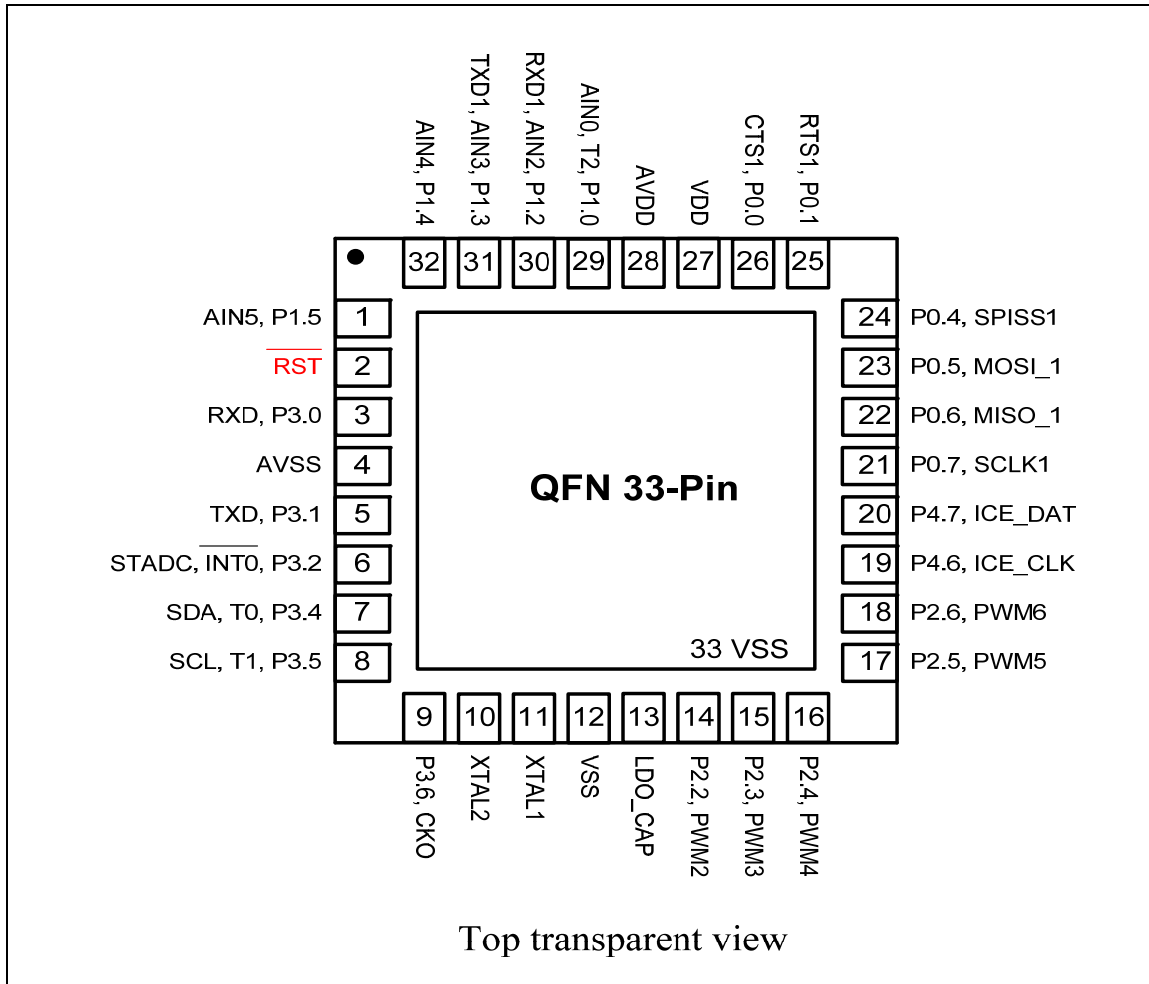

Figure 5–1 NuMicro™ M051 Series QFN33 Pin Diagram

5.2 LQFP 48 pin

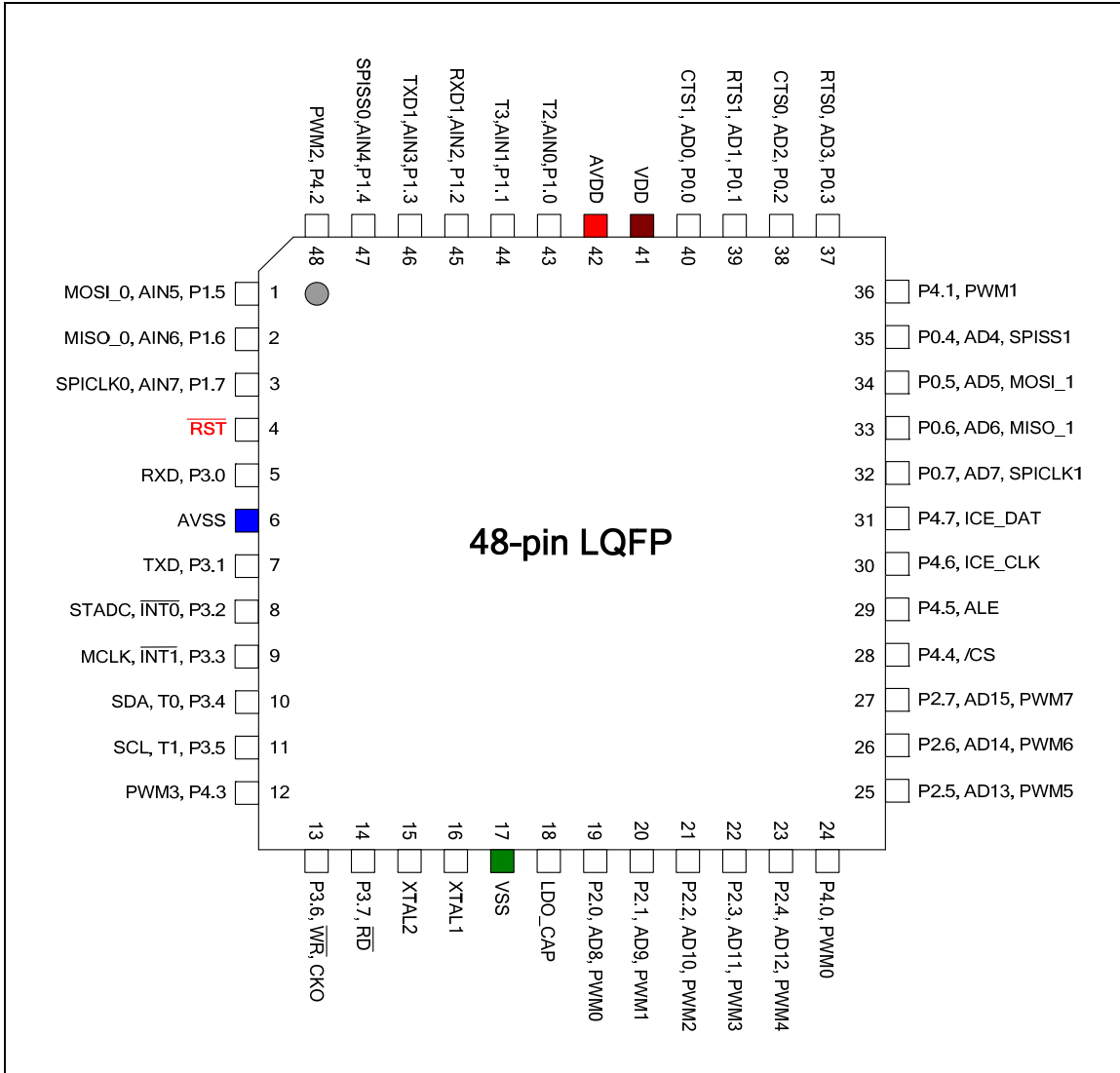

Figure 5–2 NuMicro™ M051 Series LQFP-48 Pin Diagram

5.3 Pin Description

Pin number		Symbol	Alternate Function		Type ^[1]	Description
QFN33	LQFP48		1	2		
11	16	XTAL1			I (ST)	CRYSTAL1: This is the input pin to the internal inverting amplifier. The system clock is from external crystal or resonator when FOSC[1:0] (CONFIG3[1:0]) are both logic 1 by default.
10	15	XTAL2			O	CRYSTAL2: This is the output pin from the internal inverting amplifier. It emits the inverted signal of XTAL1.
27	41	VDD			P	POWER SUPPLY: Supply voltage Digital V _{DD} for operation.
12	17	VSS			P	GROUND: Digital Ground potential.
33						
28	42	AVDD			P	POWER SUPPLY: Supply voltage Analog AV _{DD} for operation.
4	6	AVSS			P	GROUND: Analog Ground potential.
13	18	LDO_C AP			P	LDO: LDO output pin Note: It needs to be connected with a 10uF capacitor.
2	4	/RST			I (ST)	RESET: /RST pin is a Schmitt trigger input pin for hardware device reset. A "Low" on this pin for 768 clock counter of Internal RC 22.1184 MHz while the system clock is running will reset the device. /RST pin has an internal pull-up resistor allowing power-on reset by simply connecting an external capacitor to GND.
26	40	P0.0	CTS1	AD0	D, I/O	PORT0: Port 0 is an 8-bit four mode output pin and two mode input. Its multifunction pins are for CTS1, RTS1, CTS0, RTS0, SPISS1, MOSI_1, MISO_1, and SPICLK1. P0 has an alternative function as AD[7:0] while external memory interface (EBI) is enabled. These pins which are SPISS1, MOSI_1, MISO_1, and SPICLK1 for the SPI function used. CTS0/1: Clear to Send input pin for UART0/1
25	39	P0.1	RTS1	AD1	D, I/O	
NC	38	P0.2	CTS0	AD2	D, I/O	
NC	37	P0.3	RTS0	AD3	D, I/O	
24	35	P0.4	SPISS1	AD4	D, I/O	

Pin number		Symbol	Alternate Function		Type ^[1]	Description
QFN33	LQFP48		1	2		
23	34	P0.5	MOSI_1	AD5	D, I/O	RTS0/1: Request to Send output pin for UART0/1
22	33	P0.6	MISO_1	AD6	D, I/O	
21	32	P0.7	SPICLK1	AD7	D, I/O	
29	43	P1.0	T2	AIN0	I/O	<p>PORT1: Port 1 is an 8-bit four mode output pin and two mode input. Its multifunction pins are for T2, T3, RXD1, TXD1, SPISS0, MOSI_0, MISO_0, and SPICLK0.</p> <p>T2: Timer2 external input T3: Timer3 external input</p> <p>These pins which are SPISS0, MOSI_0, MISO_0, and SPICLK0 for the SPI function used.</p> <p>These pins which are AIN0~AIN7 for the 12 bits ADC function used.</p> <p>The RXD1/TXD1 pins are for UART1 function used.</p>
NC	44	P1.1	T3	AIN1	I/O	
30	45	P1.2	RXD1	AIN2	I/O	
31	46	P1.3	TXD1	AIN3	I/O	
32	47	P1.4	SPISS0	AIN4	I/O	
1	1	P1.5	MOSI_0	AIN5	I/O	
NC	2	P1.6	MISO_0	AIN6	I/O	
NC	3	P1.7	SPICLK0	AIN7	I/O	
NC	19	P2.0	PWM0	AD8	D, I/O	
NC	20	P2.1	PWM1	AD9	D, I/O	<p>PORT2: Port 2 is an 8-bit four mode output pin and two mode input. It has an alternative function</p> <p>P2 has an alternative function as AD[15:8] while external memory interface (EBI) is enabled.</p> <p>These pins which are PWM0~PWM7 for the PWM function.</p>
14	21	P2.2	PWM2	AD10	D, I/O	
15	22	P2.3	PWM3	AD11	D, I/O	
16	23	P2.4	PWM4	AD12	D, I/O	
17	25	P2.5	PWM5	AD13	D, I/O	
18	26	P2.6	PWM6	AD14	D, I/O	
NC	27	P2.7	PWM7	AD15	D, I/O	
3	5	P3.0	RXD		I/O	
5	7	P3.1	TXD		I/O	<p>PORT3: Port 3 is an 8-bit four mode output pin and two mode input. Its multifunction pins are for RXD, TXD, INT0 ,</p>



Pin number		Symbol	Alternate Function		Type ^[1]	Description
QFN33	LQFP48		1	2		
6	8	P3.2	$\overline{\text{INT0}}$	STADC	I/O	$\overline{\text{INT1}}$, T0, T1, $\overline{\text{WR}}$, and $\overline{\text{RD}}$. T0: Timer0 external input
NC	9	P3.3	$\overline{\text{INT1}}$	MCLK	I/O	T1: Timer1 external input The RXD/TXD pins are for UART0 function used.
7	10	P3.4	T0	SDA	I/O	The SDA/SCL pins are for I2C function used.
8	11	P3.5	T1	SCL	I/O	MCLK: EBI clock output pin. CKO: HCLK clock output
9	13	P3.6	$\overline{\text{WR}}$	CKO	I/O	The STADC pin is for ADC external trigger input.
NC	14	P3.7	$\overline{\text{RD}}$		I/O	
NC	24	P4.0	PWM0		I/O	PORT4: Port 4 is an 8-bit four mode output pin and two mode input. Its multifunction pins are for /CS, ALE, ICE_CLK and ICE_DAT. /CS for EBI (External Bus Interface) used. ALE (Address Latch Enable) is used to enable the address latch that separates the address from the data on Port 0 and Port 2. The ICE_CLK/ICE_DAT pins are for JTAG-ICE function used. PWM0-3 can be used from P4.0-P4.3 when EBI is active.
NC	36	P4.1	PWM1		I/O	
NC	48	P4.2	PWM2		I/O	
NC	12	P4.3	PWM3		I/O	
NC	28	P4.4	/CS		I/O	
NC	29	P4.5	ALE		I/O	
19	30	P4.6	ICE_CLK		I/O	
20	31	P4.7	ICE_DAT		I/O	

Table 5–1 NuMicro™ M051 Series Pin Description

[1] I/O type description. I: input, O: output, I/O: quasi bi-direction, D: open-drain, P: power pins, ST: Schmitt trigger.

6 FUNCTIONAL DESCRIPTION

6.1 ARM® Cortex™-M0 Core

The Cortex™-M0 processor is a configurable, multistage, 32-bit RISC processor. It has an AMBA AHB-Lite interface and includes an NVIC component. It also has optional hardware debug functionality. The processor can execute Thumb code and is compatible with other Cortex-M profile processor. The profile supports two modes - Thread and Handler modes. Handler mode is entered as a result of an exception. An exception return can only be issued in Handler mode. Thread mode is entered on Reset, and can be entered as a result of an exception return.

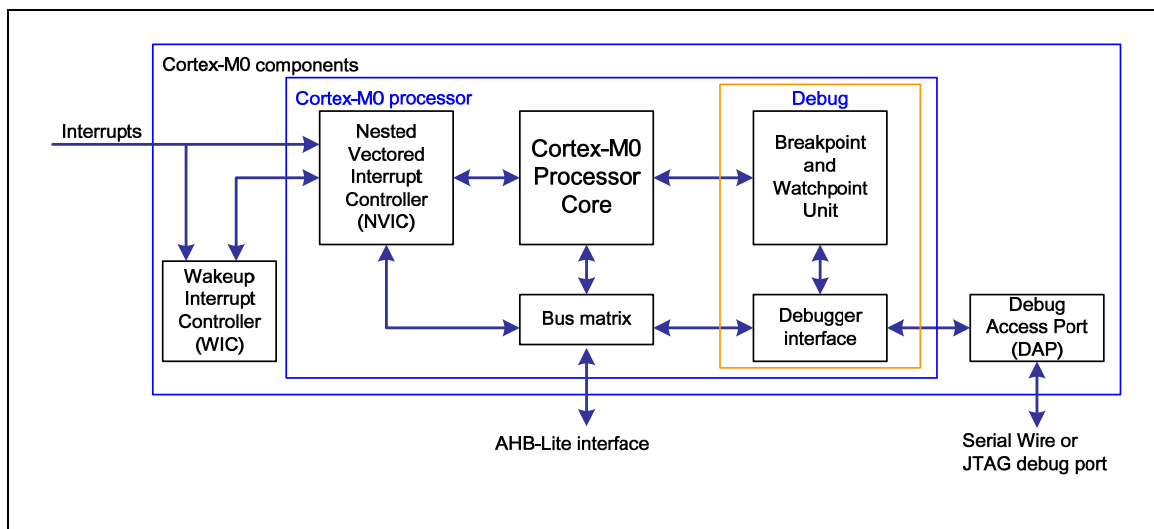

Figure 6-1 Functional Block Diagram

The implemented device provides:

A low gate count processor the features:

- The ARMv6-M Thumb® instruction set.
- Thumb-2 technology.
- ARMv6-M compliant 24-bit SysTick timer.
- A 32-bit hardware multiplier.
- The system interface supports little-endian data accesses.
- The ability to have deterministic, fixed-latency, interrupt handling.

- Load/store-multiples and multicycle-multiplies that can be abandoned and restarted to facilitate rapid interrupt handling.
- C Application Binary Interface compliant exception model.
This is the ARMv6-M, C Application Binary Interface(C-ABI) compliant exception model that enables the use of pure C functions as interrupt handlers.
- Low power sleep-mode entry using Wait For Interrupt (WFI), Wait For Event(WFE) instructions, or the return from interrupt sleep-on-exit feature.

NVIC features:

- 32 external interrupt inputs, each with four levels of priority.
- Dedicated non-Maskable Interrupt (NMI) input.
- Support for both level-sensitive and pulse-sensitive interrupt lines
- Wake-up Interrupt Controller (WIC), supports ultra-low power sleep mode.

Debug support:

- Four hardware breakpoints.
- Two watchpoints.
- Program Counter Sampling Register (PCSR) for non-intrusive code profiling.
- Single step and vector catch capabilities.

Bus interfaces:

- Single 32-bit AMBA-3 AHB-Lite system interface that provides simple integration to all system peripherals and memory.
- Single 32-bit slave port that supports the DAP (Debug Access Port).

6.2 System Manager

6.2.1 Overview

The following functions are included in system manager section

- System Resets
- System Memory Map
- System management registers for Part Number ID, chip reset and on-chip module reset , multi-functional pin control
- System Timer (SysTick)
- Nested Vectored Interrupt Controller (NVIC)
- System Control registers

6.2.2 System Reset

The system reset includes one of the list below event occurs. For these reset event flags can be read by RSTRC register.

- The Power-On Reset (POR)
- The low level on the /RESET pin
- Watchdog Time Out Reset (WDT)
- Low Voltage Reset (LVR)
- Brownout-Detected Reset (BOD)
- CPU Reset
- System Reset

6.2.3 System Power Architecture

In this device, the power architecture is divided into two segments.

- Analog power from AVDD and AVSS provides the power for analog module operation.
- Digital power from VDD and VSS supplies the power to the internal regulator which provides a fixed 2.5V power for digital operation and I/O pins.

The outputs of internal voltage regulator, which is LDO, require an external capacitor which should be located close to the corresponding pin. The Figure 6–2 shows the power architecture of this device.

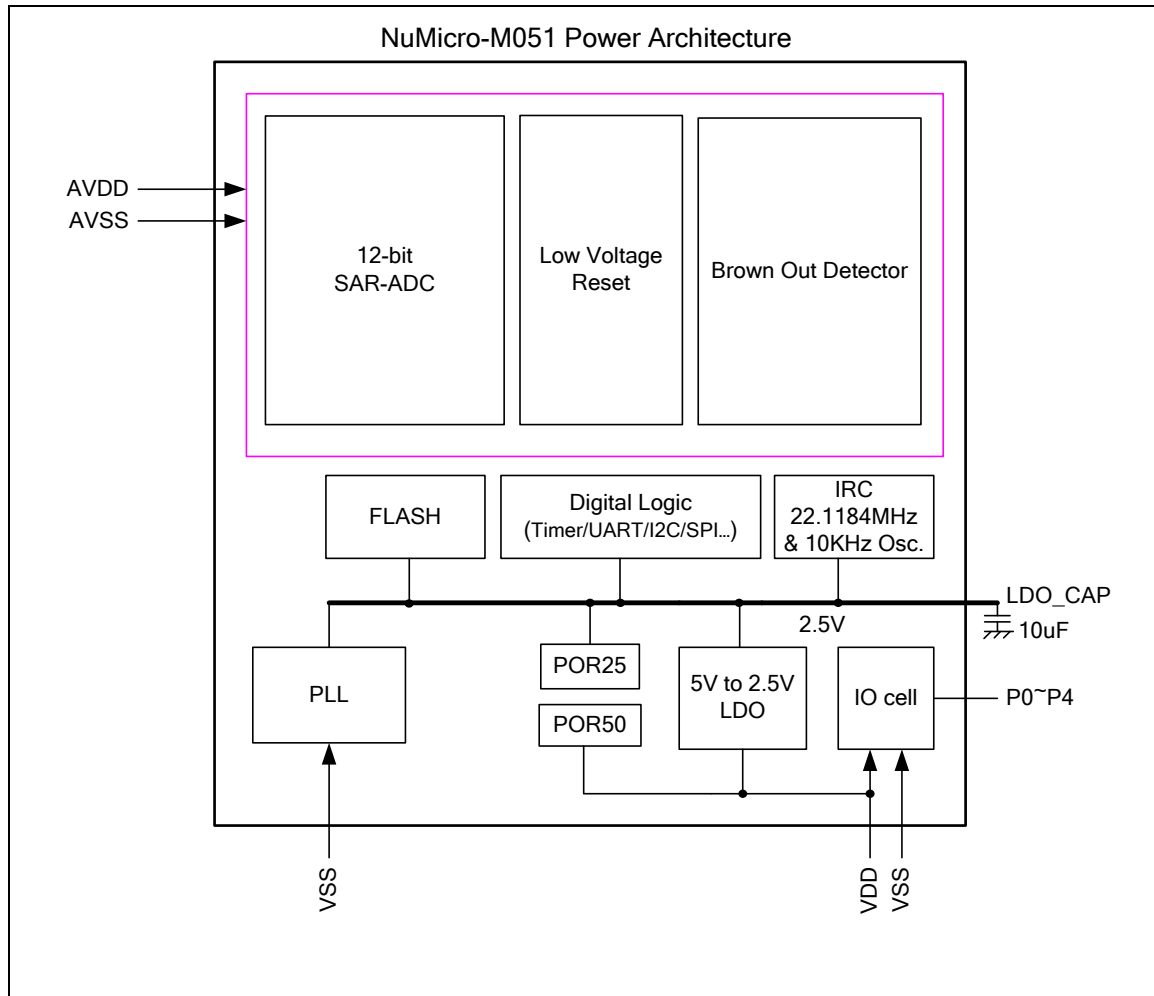

Figure 6–2 NuMicro M051™ Series Power Architecture Diagram

6.2.4 System Timer (SysTick)

The Cortex-M0 includes an integrated system timer, SysTick. SysTick provides a simple, 24-bit clear-on-write, decrementing, wrap-on-zero counter with a flexible control mechanism. The counter can be used as a Real Time Operating System (RTOS) tick timer or as a simple counter.

When system timer is enabled, it will count down from the value in the SysTick Current Value Register (SYST_CVR) to zero, and reload (wrap) to the value in the SysTick Reload Value Register (SYST_RVR) on the next clock edge, then decrement on subsequent clocks. When the counter transitions to zero, the COUNTFLAG status bit is set. The COUNTFLAG bit clears on reads.

The SYST_CVR value is UNKNOWN on reset. Software should write to the register to clear it to zero before enabling the feature. This ensures the timer will count from the SYST_RVR value

rather than an arbitrary value when it is enabled.

If the SYST_RVR is zero, the timer will be maintained with a current value of zero after it is reloaded with this value. This mechanism can be used to disable the feature independently from the timer enable bit.

For more detailed information, please refer to the documents “ARM® Cortex™-M0 Technical Reference Manual” and “ARM® v6-M Architecture Reference Manual”.

6.2.5 Nested Vectored Interrupt Controller (NVIC)

Cortex-M0 provides an interrupt controller as an integral part of the exception mode, named as “Nested Vectored Interrupt Controller (NVIC)”. It is closely coupled to the processor kernel and provides following features:

- Nested and Vectored interrupt support
- Automatic processor state saving and restoration
- Dynamic priority changing
- Reduced and deterministic interrupt latency

The NVIC prioritizes and handles all supported exceptions. All exceptions are handled in “Handler Mode”. This NVIC architecture supports 32 (IRQ[31:0]) discrete interrupts with 4 levels of priority. All of the interrupts and most of the system exceptions can be configured to different priority levels. When an interrupt occurs, the NVIC will compare the priority of the new interrupt to the current running one’s priority. If the priority of the new interrupt is higher than the current one, the new interrupt handler will override the current handler.

When any interrupts is accepted, the starting address of the interrupt service routine (ISR) is fetched from a vector table in memory. There is no need to determine which interrupt is accepted and branch to the starting address of the correlated ISR by software. While the starting address is fetched, NVIC will also automatically save processor state including the registers “PC, PSR, LR, R0~R3, R12” to the stack. At the end of the ISR, the NVIC will restore the mentioned registers from stack and resume the normal execution. Thus it will take less and deterministic time to process the interrupt request.

The NVIC supports “Tail Chaining” which handles back-to-back interrupts efficiently without the overhead of states saving and restoration and therefore reduces delay time in switching to pending ISR at the end of current ISR. The NVIC also supports “Late Arrival” which improves the efficiency of concurrent ISRs. When a higher priority interrupt request occurs before the current ISR starts to execute (at the stage of state saving and starting address fetching), the NVIC will give priority to the higher one without delay penalty. Thus it advances the real-time capability.

For more detailed information, please refer to the documents “ARM® Cortex™-M0 Technical Reference Manual” and “ARM® v6-M Architecture Reference Manual”.



6.2.5.1 Exception Model and System Interrupt Map

The Table 6–1 lists the exception model supported by NuMicro M051™ series. Software can set four levels of priority on some of these exceptions as well as on all interrupts. The highest user-configurable priority is denoted as “0” and the lowest priority is denoted as “3”. The default priority of all the user-configurable interrupts is “0”. Note that priority “0” is treated as the fourth priority on the system, after three system exceptions “Reset”, “NMI” and “Hard Fault”.

Exception Number	Vector Address	Interrupt Number (Bit in Interrupt Registers)	Interrupt Name	Source IP	Interrupt description	Power Down Wakeup
1-15	0x00-0x3C	-	-	-	System exceptions	
16	0x40	0	BOD_OUT	Brownout	Brownout low voltage detected interrupt	Yes
17	0x44	1	WDT_INT	WDT	Watch Dog Timer interrupt	Yes
18	0x48	2	EINT0	GPIO	External signal interrupt from P3.2 pin	Yes
19	0x4C	3	EINT1	GPIO	External signal interrupt from P3.3 pin	Yes
20	0x50	4	GP01_INT	GPIO	External signal interrupt from P0[7:0] / P1[7:0]	Yes
21	0x54	5	GP234_INT	GPIO	External interrupt from P2[7:0]/P3[7:0]/P4[7:0], except P32 and P33	Yes
22	0x58	6	PWMA_INT	PWM0~3	PWM0, PWM1, PWM2 and PWM3 interrupt	No
23	0x5C	7	PWMB_INT	PWM4~7	PWM4, PWM5, PWM6 and PWM7 interrupt	No
24	0x60	8	TMR0_INT	TMR0	Timer 0 interrupt	No
25	0x64	9	TMR1_INT	TMR1	Timer 1 interrupt	No
26	0x68	10	TMR2_INT	TMR2	Timer 2 interrupt	No
27	0x6C	11	TMR3_INT	TMR3	Timer 3 interrupt	No
28	0x70	12	UART0_INT	UART0	UART0 interrupt	Yes
29	0x74	13	UART1_INT	UART1	UART1 interrupt	Yes

30	0x78	14	SPI0_INT	SPI0	SPI0 interrupt	No
31	0x7C	15	SPI1_INT	SPI1	SPI1 interrupt	No
32-33	0x80-0x84	16-17	-	-	-	-
34	0x88	18	I2C_INT	I2C	I2C interrupt	No
35-43	0x8C-0xAC	19-27	-	-	-	-
44	0xB0	28	PWRWU_INT	CLKC	Clock controller interrupt for chip wake up from power-down state	Yes
45	0xB4	29	ADC_INT	ADC	ADC interrupt	No
46-47	0xB8-0xBC	30-31	-	-	-	-

Table 6–1 Exception Model

Exception Name	Vector Number	Priority
Reset	1	-3
NMI	2	-2
Hard Fault	3	-1
Reserved	4 ~ 10	Reserved
SVCcall	11	Configurable
Reserved	12 ~ 13	Reserved
PendSV	14	Configurable
SysTick	15	Configurable
Interrupt (IRQ0 ~ IRQ31)	16 ~ 47	Configurable

Table 6–2 System Interrupt Map

6.2.5.2 Vector Table

When any interrupts is accepted, the processor will automatically fetch the starting address of the interrupt service routine (ISR) from a vector table in memory. For ARMv6-M, the vector table base address is fixed at 0x00000000. The vector table contains the initialization value for the stack pointer on reset, and the entry point addresses for all exception handlers. The vector number on previous page defines the order of entries in the vector table associated with exception handler

Publication Release Date: Mar 15, 2011

entry as illustrated in previous section.

Vector Table Word Offset	Description
0	SP_main – The Main stack pointer
Vector Number	Exception Entry Pointer using that Vector Number

Table 6–3 Vector Table Format

6.2.5.3 Operation Description

NVIC interrupts can be enabled and disabled by writing to their corresponding Interrupt Set-Enable or Interrupt Clear-Enable register bit-field. The registers use a write-1-to-enable and write-1-to-clear policy, both registers reading back the current enabled state of the corresponding interrupts. When an interrupt is disabled, interrupt assertion will cause the interrupt to become Pending, however, the interrupt will not activate. If an interrupt is Active when it is disabled, it remains in its Active state until cleared by reset or an exception return. Clearing the enable bit prevents new activations of the associated interrupt.

NVIC interrupts can be pended/un-pended using a complementary pair of registers to those used to enable/disable the interrupts, named the Set-Pending Register and Clear-Pending Register respectively. The registers use a write-1-to-enable and write-1-to-clear policy, both registers reading back the current pended state of the corresponding interrupts. The Clear-Pending Register has no effect on the execution status of an Active interrupt.

NVIC interrupts are prioritized by updating an 8-bit field within a 32-bit register (each register supporting four interrupts).

The general registers associated with the NVIC are all accessible from a block of memory in the System Control Space and will be described in next section.

6.3 Clock Controller

6.3.1 Overview

The clock controller generates the clocks for the whole chip, including system clocks and all peripheral clocks. The clock controller also implements the power control function with the individually clock ON/OFF control, clock source selection and a 4-bit clock divider. The chip will not enter power-down mode until CPU sets the power down enable bit (PWR_DOWN_EN) and Cortex-M0 core executes the WFI instruction. After that, chip enter power-down mode and wait for wake-up interrupt source triggered to leave power-down mode. In the power down mode, the clock controller turns off the external crystal and internal 22.1184 MHz oscillator to reduce the overall system power consumption.

6.3.2 Clock Generator Block Diagram

The clock generator consists of 4 sources which list below:

- One external 4~24 MHz crystal
- One internal 22.1184 MHz RC oscillator
- One programmable PLL FOUT(PLL source consists of external 4~24 MHz crystal and internal 22.1184M)
- One internal 10 kHz oscillator

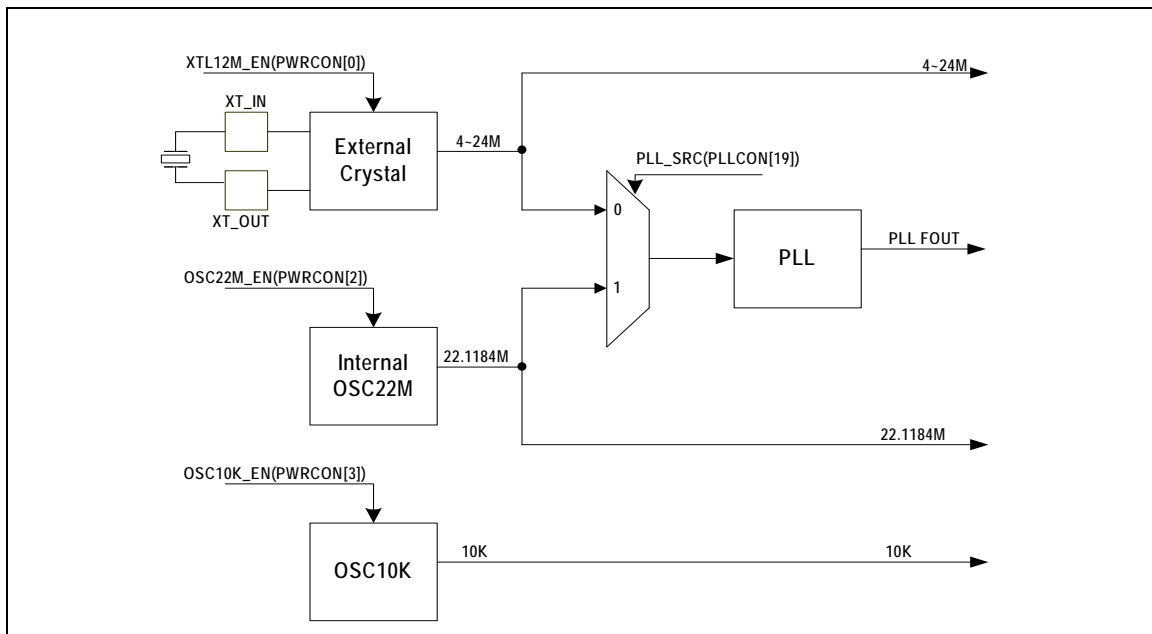

Figure 6–3 Clock generator block diagram

6.3.3 System Clock & SysTick Clock

The system clock has 4 clock sources which were generated from clock generator block. The clock source switch depends on the register HCLK_S(CLKSEL0[2:0]). The block diagram is shown in the Figure 6–4.

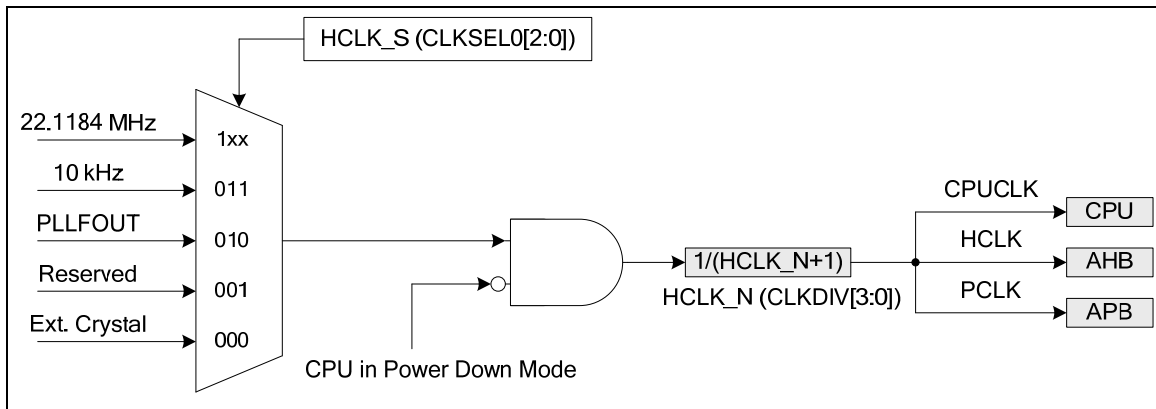

Figure 6–4 System Clock Block Diagram

The clock source of SysTick in Cortex-M0 core can use CPU clock or external clock (SYST_CSR[2]). If using external clock, the SysTick clock (STCLK) has 4 clock sources. The clock source switch depends on the setting of the register STCLK_S (CLKSEL0[5:3]). The block diagram is shown in the Figure 6–5.

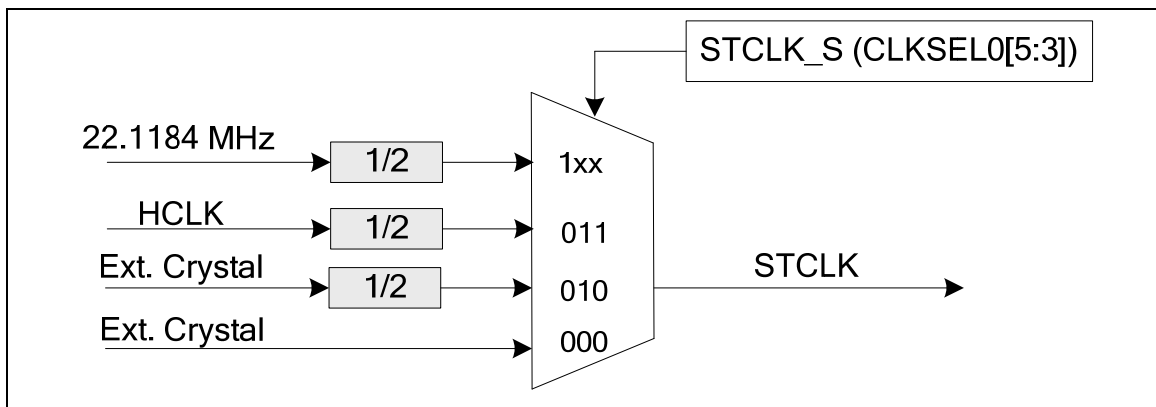

Figure 6–5 SysTick clock Control Block Diagram

6.3.4 AHB Clock Source Select

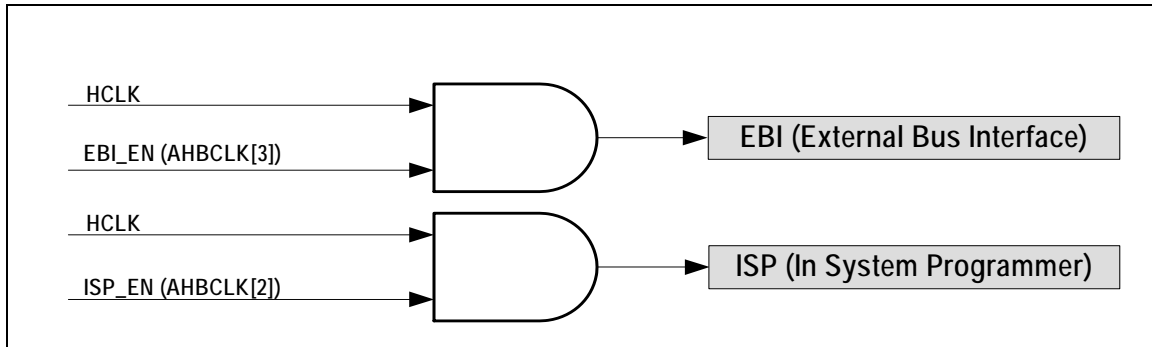

Figure 6–6 AHB Clock Source for HCLK

6.3.5 Peripherals Clock Source Select

The peripherals clock had different clock source switch setting which depends on the different peripheral. Please refer the CLKSEL1 & APBCLK register description in chapter 6.3.9.

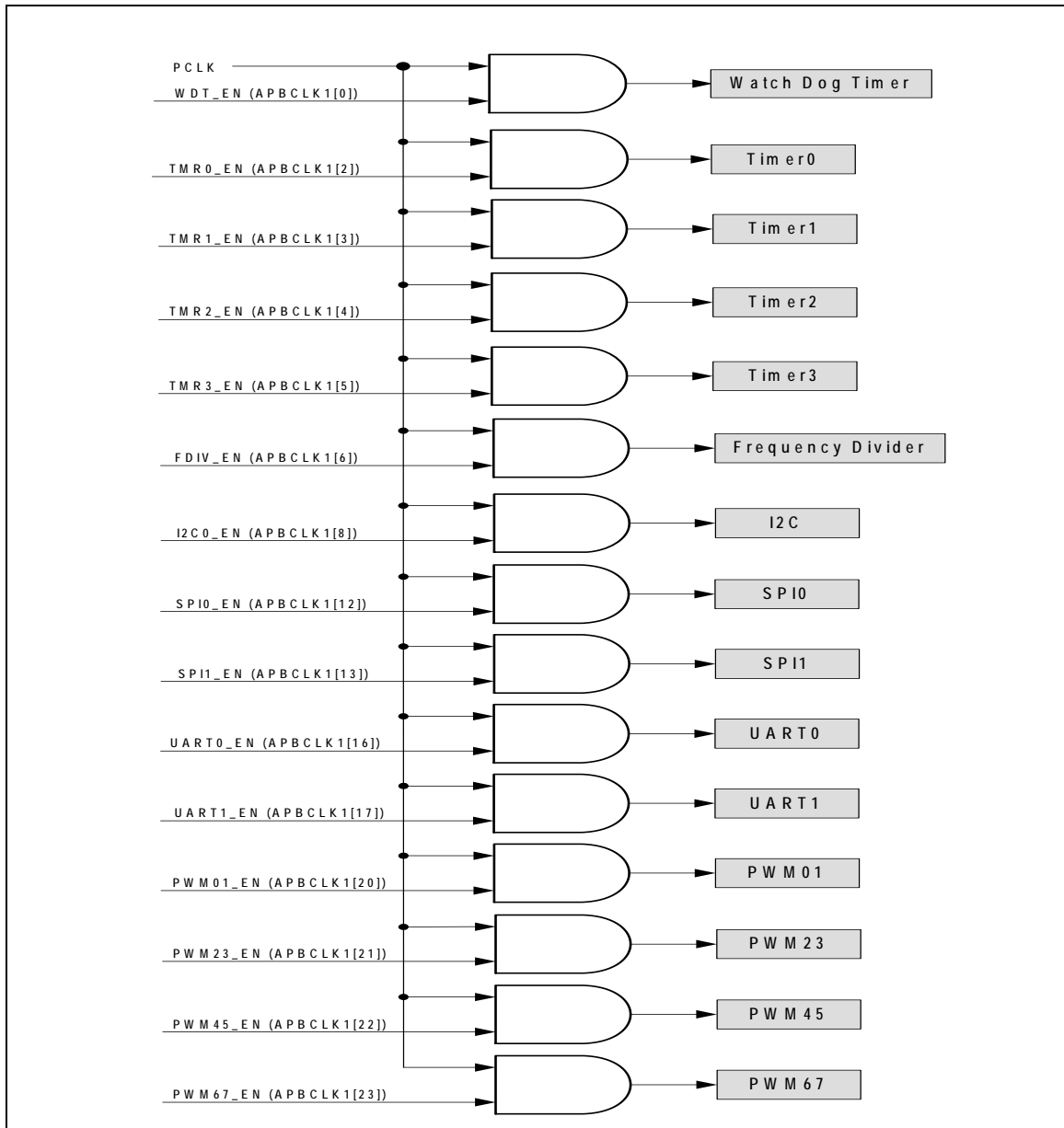

Figure 6-7 Peripherals Clock Source Select for PCLK

6.3.6 Power Down Mode (Deep Sleep Mode) Clock

When chip enter into power down mode, most of clock sources, peripheral clocks and system clock will be disabled. Some of clock sources and peripherals clock are still active in power down mode.

For these clocks which still keep active list below:

Publication Release Date: Mar 15, 2011
Revision V1.0

Clock Generator

- Internal 10 kHz oscillator clock
- Peripherals Clock (When these IP adopt 10 kHz as clock source)
- Watch Dog Clock
- Timer 0/1/2/3 Clock
- PWM Clock

6.3.7 Frequency Divider Output

This device is equipped a power-of-2 frequency divider which is composed by 16 chained divide-by-2 shift registers. One of the 16 shift register outputs selected by a sixteen to one multiplexer is reflected to P3.6. Therefore there are 16 options of power-of-2 divided clocks with the frequency from $F_{in}/2^1$ to $F_{in}/2^{17}$ where F_{in} is input clock frequency to the clock divider.

The output formula is $F_{out} = F_{in}/2^{(N+1)}$, where F_{in} is the input clock frequency, F_{out} is the clock divider output frequency and N is the 4-bit value in `FREQDIV.FSEL[3:0]`.

When write 1 to `DIVIDER_EN` (`FRQDIV[4]`), the chained counter starts to count. When write 0 to `DIVIDER_EN` (`FRQDIV[4]`), the chained counter continuously runs till divided clock reaches low state and stay in low state.

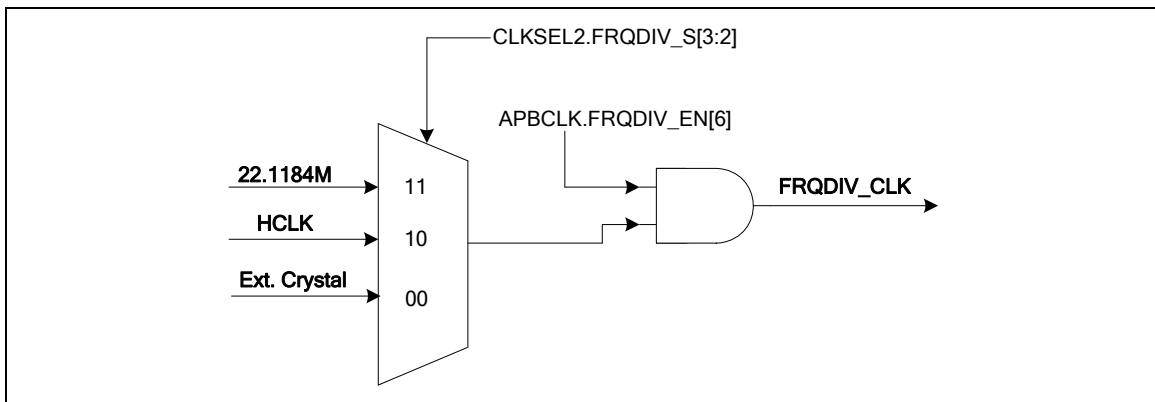

Figure 6–8 Clock Source of Frequency Divider

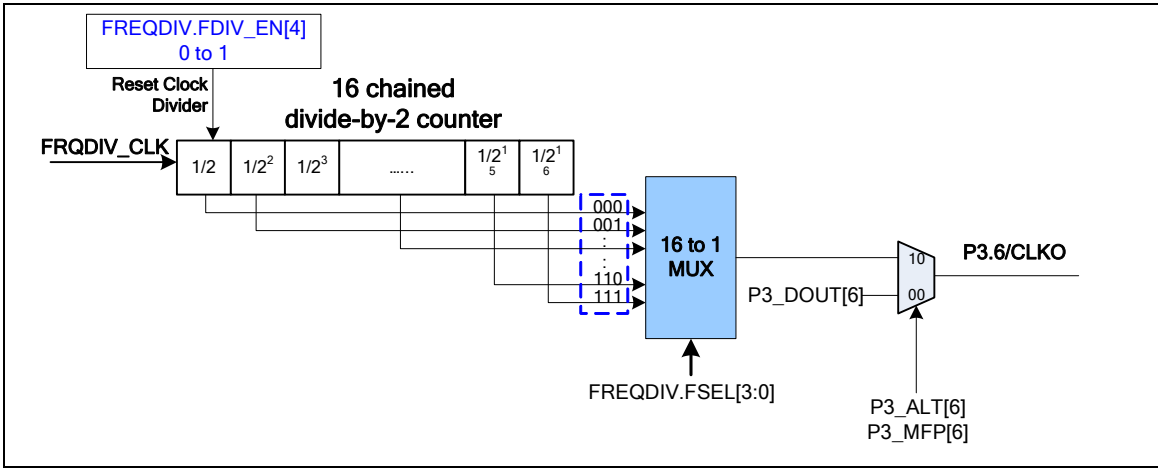

Figure 6–9 Block Diagram of Frequency Divider

6.4 General Purpose I/O

6.4.1 Overview

There are 40 General Purpose I/O pins shared with special feature functions in this MCU. The 40 pins are arranged in 5 ports named with P0, P1, P2, P3 and P4. Each port equips maximum 8 pins. Each one of the 40 pins is independent and has the corresponding register bits to control the pin mode function and data

The I/O type of each of I/O pins can be software configured individually as input, output, open-drain or quasi-bidirectional mode. The all pins of I/O type stay in quasi-bidirectional mode and port data register Px_DOUT[7:0] resets to 0x000_00FF. Each I/O pin equips a very weakly individual pull-up resistor which is about 110K Ω ~300K Ω for V_{DD} is from 5.0V to 2.5V.

6.4.1.1 Input Mode Explanation

Set Px_PMD(PMDn[1:0]) to 00b the Px[n] pin is in Input mode and the I/O pin is in tri-state(high impedance) without output drive capability. The Px_PIN value reflects the status of the corresponding port pins.

6.4.1.2 Output Mode Explanation

Set Px_PMD(PMDn[1:0]) to 2'b01 the Px[n] pin is in Output mode and the I/O pin supports digital output function with source/sink current capability. The bit value in the corresponding bit [n] of Px_DOUT is driven on the pin.

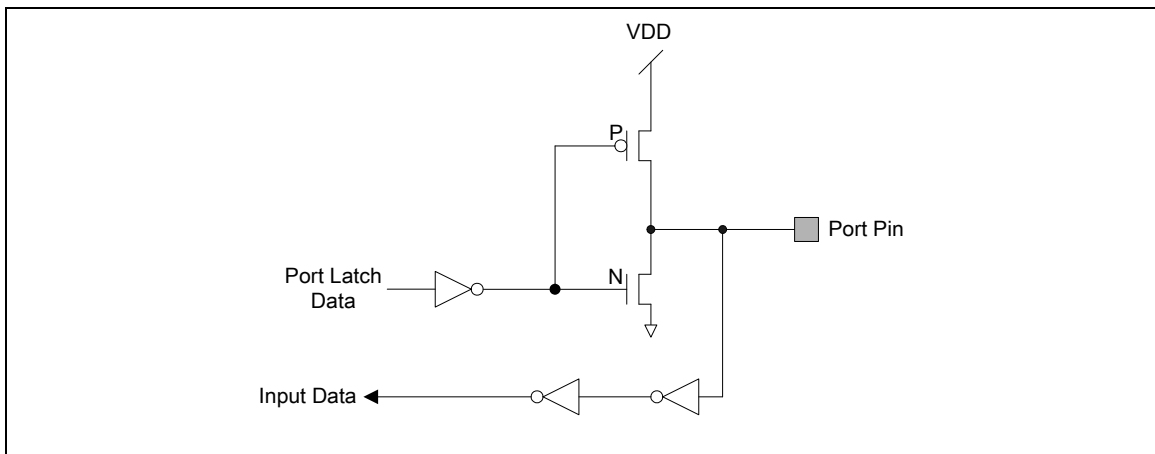

Figure 6–10 Push-Pull Output

6.4.1.3 Open-Drain Mode Explanation

Set Px_PMD(PMDn[1:0]) to 2'b10 the Px[n] pin is in Open-Drain mode and the I/O pin supports digital output function but only with sink current capability, an additional pull-up resistor is needed for driving high state. If the bit value in the corresponding bit [n] of Px_DOUT is “0”, the pin drive a “low” output on the pin. If the bit value in the corresponding bit [n] of Px_DOUT is “1”, the pin output drives high that is controlled by the internal pull-up resistor or the external pull high resistor.

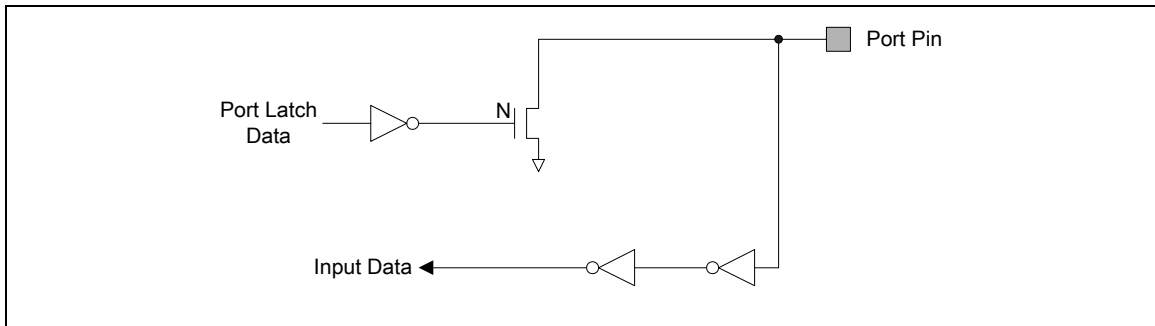

Figure 6-11 Open-Drain Output

6.4.1.4 Quasi-bidirectional Mode Explanation

Set $Px_PMD(PMDn[1:0])$ to $2'b11$ the $Px[n]$ pin is in Quasi-bidirectional mode and the I/O pin supports digital output and input function at the same time but the source current is only up to hundreds μA . Before the digital input function is performed the corresponding bit in Px_DOUT must be set to 1. The quasi-bidirectional output is common on the 80C51 and most of its derivatives. If the bit value in the corresponding bit $[n]$ of Px_DOUT is "0", the pin drive a "low" output on the pin. If the bit value in the corresponding bit $[n]$ of Px_DOUT is "1", the pin will check the pin value. If pin value is high, no action takes. If pin state is low, then pin will drive strong high with 2 clock cycles on the pin and then disable the strong output drive and then the pin status is control by internal pull-up resistor. Note that the source current capability in quasi-bidirectional mode is only about 200 μA to 30 μA for VDD is form 5.0V to 2.5V

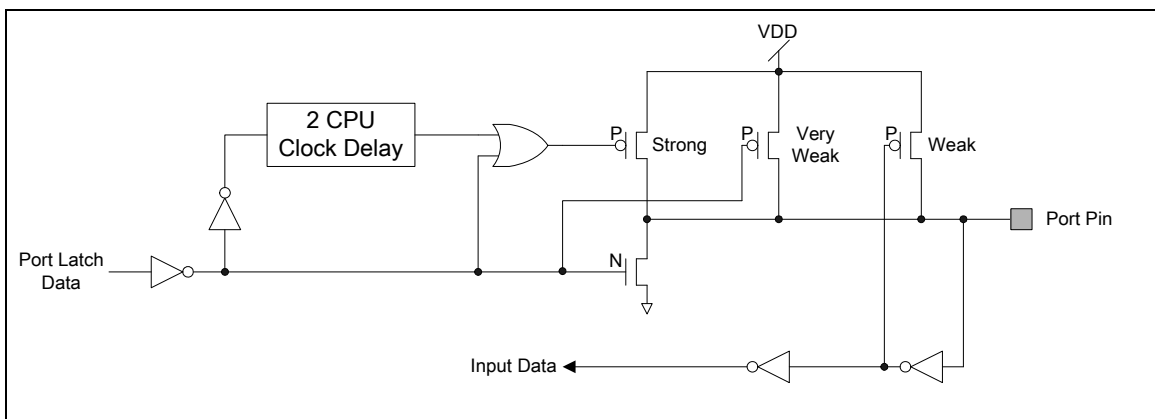

Figure 6-12 Quasi-bidirectional I/O Mode

6.5 I2C Serial Interface Controller (Master/Slave)

6.5.1 Overview

I2C is a two-wire, bi-directional serial bus that provides a simple and efficient method of data exchange between devices. The I2C standard is a true multi-master bus including collision detection and arbitration that prevents data corruption if two or more masters attempt to control the bus simultaneously.

Data is transferred between a Master and a Slave synchronously to SCL on the SDA line on a byte-by-byte basis. Each data byte is 8 bits long. There is one SCL clock pulse for each data bit with the MSB being transmitted first. An acknowledge bit follows each transferred byte. Each bit is sampled during the high period of SCL; therefore, the SDA line may be changed only during the low period of SCL and must be held stable during the high period of SCL. A transition on the SDA line while SCL is high is interpreted as a command (START or STOP). Please refer to the Figure 6–13 for more detail I2C BUS Timing.

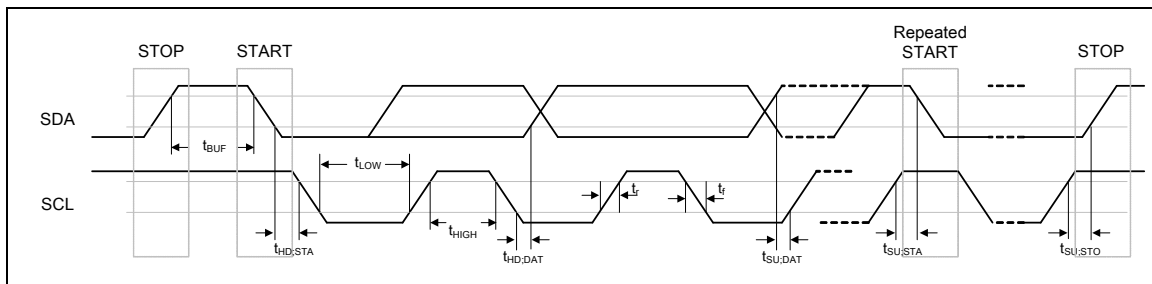

Figure 6–13 I2C Bus Timing

The device's on-chip I2C provides the serial interface that meets the I2C bus standard mode specification. The I2C port handles byte transfers autonomously. To enable this port, the bit ENS1 in I2CON should be set to '1'. The I2C H/W interfaces to the I2C bus via two pins: SDA (Px.y, serial data line) and SCL (Px.y, serial clock line). Pull up resistor is needed for Pin Px.y and Px.y for I2C operation as these are open drain pins. When the I/O pins are used as I2C port, user must set the pins function to I2C in advance.

6.5.2 Features

The I2C bus uses two wires (SDA and SCL) to transfer information between devices connected to the bus. The main features of the bus are:

- Support Master and Slave mode
- Bidirectional data transfer between masters and slaves
- Multi-master bus (no central master)
- Arbitration between simultaneously transmitting masters without corruption of serial data on the bus

- Serial clock synchronization allows devices with different bit rates to communicate via one serial bus
- Serial clock synchronization can be used as a handshake mechanism to suspend and resume serial transfer
- Built-in a 14-bit time-out counter will request the I2C interrupt if the I2C bus hangs up and timer-out counter overflows.
- External pull-up are needed for high output
- Programmable clocks allow versatile rate control
- Supports 7-bit addressing mode
- I2C-bus controllers support multiple address recognition (Four slave address with mask option)

6.6 PWM Generator and Capture Timer

6.6.1 Overview

NuMicro M051™ series has 2 sets of PWM group supports 4 sets of PWM Generators which can be configured as 8 independent PWM outputs, PWM0~PWM7, or as 4 complementary PWM pairs, (PWM0, PWM1), (PWM2, PWM3), (PWM4, PWM5) and (PWM6, PWM7) with 4 programmable dead-zone generators.

Each PWM Generator has one 8-bit prescaler, one clock divider with 5 divided frequencies (1, 1/2, 1/4, 1/8, 1/16), two PWM Timers including two clock selectors, two 16-bit PWM down-counters for PWM period control, two 16-bit comparators for PWM duty control and one dead-zone generator. The 4 sets of PWM Generators provide eight independent PWM interrupt flags which are set by hardware when the corresponding PWM period down counter reaches zero. Each PWM interrupt source with its corresponding enable bit can cause CPU to request PWM interrupt. The PWM generators can be configured as one-shot mode to produce only one PWM cycle signal or auto-reload mode to output PWM waveform continuously.

When PCR.DZEN01 is set, PWM0 and PWM1 perform complementary PWM paired function; the paired PWM timing, period, duty and dead-time are determined by PWM0 timer and Dead-zone generator 0. Similarly, the complementary PWM pairs of (PWM2, PWM3), (PWM4, PWM5) and (PWM6, PWM7) are controlled by PWM2, PWM4 and PWM6 timers and Dead-zone generator 2, 4 and 6, respectively. Refer to figures bellowed for the architecture of PWM Timers.

To prevent PWM driving output pin with unsteady waveform, the 16-bit period down counter and 16-bit comparator are implemented with double buffer. When user writes data to counter/comparator buffer registers the updated value will be load into the 16-bit down counter/comparator at the time down counter reaching zero. The double buffering feature avoids glitch at PWM outputs.

When the 16-bit period down counter reaches zero, the interrupt request is generated. If PWM-timer is set as auto-reload mode, when the down counter reaches zero, it is reloaded with PWM Counter Register (CNRx) automatically then start decreasing, repeatedly. If the PWM-timer is set as one-shot mode, the down counter will stop and generate one interrupt request when it reaches zero.

The value of PWM counter comparator is used for pulse high width modulation. The counter control logic changes the output to high level when down-counter value matches the value of compare register.

The alternate feature of the PWM-timer is digital input Capture function. If Capture function is enabled the PWM output pin is switched as capture input mode. The Capture0 and PWM0 share one timer which is included in PWM 0; and the Capture1 and PWM1 share PWM1 timer, and etc. Therefore user must setup the PWM-timer before enable Capture feature. After capture feature is enabled, the capture always latched PWM-counter to Capture Rising Latch Register (CRLR) when input channel has a rising transition and latched PWM-counter to Capture Falling Latch Register (CFLR) when input channel has a falling transition. Capture channel 0 interrupt is programmable by setting CCR0.CRL_IE0[1] (Rising latch Interrupt enable) and CCR0.CFL_IE0[2] (Falling latch Interrupt enable) to decide the condition of interrupt occur.

Capture channel 1 has the same feature by setting CCR0.CRL_IE1[17] and CCR0.CFL_IE1[18]. And capture channel 0 to channel 3 on each group have the same feature by setting the corresponding control bits in CCR0 and CCR2. For each group, whenever Capture issues Interrupt 0/1/2/3, the PWM counter 0/1/2/3 will be reload at this moment.

The maximum captured frequency that PWM can capture is confined by the capture interrupt latency. When capture interrupt occurred, software will do at least three steps, they are: Read PIIRx to get interrupt source and Read PWM_CRLx/PWM_CFLx(x=0 and 3) to get capture value and finally write 1 to clear PIIRx. If interrupt latency will take time T0 to finish, the capture signal mustn't transition during this interval (T0). In this case, the maximum capture frequency will be $1/T0$. For example:

HCLK = 50 MHz, PWM_CLK = 25 MHz, Interrupt latency is 900 ns

So the maximum capture frequency will is $1/900\text{ns} \approx 1000$ kHz

6.6.2 Features

6.6.2.1 PWM function features:

PWM group has two PWM generators. Each PWM generator supports one 8-bit prescaler, one clock divider, two PWM-timers (down counter), one dead-zone generator and two PWM outputs.

- Up to 16 bits resolution
- PWM Interrupt request synchronized with PWM period
- One-shot or Auto-reload mode PWM
- Up to 2 PWM group (PWMA/PWMB) to support 8 PWM channels

6.6.2.2 Capture Function Features:

- Timing control logic shared with PWM Generators
- 8 capture input channels shared with 8 PWM output channels
- Each channel supports one rising latch register (CRLR), one falling latch register (CFLR) and Capture interrupt flag (CAPIFx)

6.7 Serial Peripheral Interface (SPI) Controller

6.7.1 Overview

The Serial Peripheral Interface (SPI) is a synchronous serial data communication protocol which operates in full duplex mode. Devices communicate in master/slave mode with 4-wire bi-direction interface. NuMicro M051™ series contains up to two sets of SPI controller performing a serial-to-parallel conversion on data received from a peripheral device, and a parallel-to-serial conversion on data transmitted to a peripheral device. Each set of SPI controller can be set as a master; it also can be configured as a slave device controlled by an off-chip master device.

6.7.2 Features

- Up to two sets of SPI controller
- Support master or slave mode operation
- Configurable bit length up to 32 bits of a transfer word and configurable word numbers up to 2 of a transaction, so the maximum bit length is 64 bits for each data transfer
- Provide burst mode operation, transmit/receive can be transferred up to two times word transaction in one transfer
- Support MSB or LSB first transfer
- Byte or word Suspend Mode
- Variable output serial clock frequency in master mode
- Support two programmable serial clock frequencies in master mode

6.8 Timer Controller

6.8.1 Overview

The timer controller includes four 32-bit timers, TIMER0~TIMER3, which allows user to easily implement a timer control for applications. The timer can perform functions like frequency measurement, interval measurement, clock generation, delay timing, and so on. The timer can generate an interrupt signal upon timeout, or provide the current value of count during operation.

6.8.2 Features:

- Provides four channels of 32-bit timers with one 8-bit pre-scale counter with four 24-bit up-timer
- Independent clock source for each timer.
- 24-bit timer value is readable through TDR (Timer Data Register)
- Provides one-shot, periodic and toggle operation modes.

6.9 Watchdog Timer (WDT)

6.9.1 Overview

The purpose of Watchdog Timer is to perform a system reset when system runs into an unknown state. This prevents system from hanging for an infinite period of time. Besides, this Watchdog Timer supports another function to wakeup CPU from power-down mode. The watchdog timer includes a 18-bit free running counter with programmable time-out intervals. Table 6–4 shows the watchdog timeout interval selection and Figure 6–14 shows the timing of watchdog interrupt signal and reset signal.

Setting WTE (WDTCR [7]) enables the watchdog timer and the WDT counter starts counting up. When the counter reaches the selected time-out interval, Watchdog timer interrupt flag WTIF will be set immediately to request a WDT interrupt if the watchdog timer interrupt enable bit WTIE is set, in the meanwhile, a specified delay time ($1024 * T_{WDT}$) follows the time-out event. User must set WTR (WDTCR [0]) (Watchdog timer reset) high to reset the 18-bit WDT counter to avoid CPU from Watchdog timer reset before the delay time expires. WTR bit is cleared automatically by hardware after WDT counter is reset. There are eight time-out intervals with specific delay time which are selected by Watchdog timer interval select bits WTIS (WDTCR [10:8]). If the WDT counter has not been cleared after the specific delay time expires, the watchdog timer will set Watchdog Timer Reset Flag (WTRF) high and reset CPU. This reset will last 63 WDT clocks (T_{RST}) then CPU restarts executing program from reset vector (0x0000 0000). WTRF will not be cleared by Watchdog reset. User may poll WTRF by software to recognize the reset source. WDT also provides wakeup function. When chip is powered down and the Watchdog Timer Wakeup Function Enable bit (WDTR[4]) is set, if the WDT counter has not been cleared after the specific delay time expires, the chip will be waken up from power down state.

WTIS	Timeout Interval Selection T_{TIS}	Interrupt Period T_{INT}	WTR Timeout Interval (WDT_CLK=10 kHz) Min. T_{WTR} ~ Max. T_{WTR}
000	$2^4 * T_{WDT}$	$1024 * T_{WDT}$	1.6 ms ~ 104 ms
001	$2^6 * T_{WDT}$	$1024 * T_{WDT}$	6.4 ms ~ 108.8 ms
010	$2^8 * T_{WDT}$	$1024 * T_{WDT}$	25.6 ms ~ 128 ms
011	$2^{10} * T_{WDT}$	$1024 * T_{WDT}$	102.4 ms ~ 204.8 ms
100	$2^{12} * T_{WDT}$	$1024 * T_{WDT}$	409.6 ms ~ 512 ms
101	$2^{14} * T_{WDT}$	$1024 * T_{WDT}$	1.6384 s ~ 1.7408 s
110	$2^{16} * T_{WDT}$	$1024 * T_{WDT}$	6.5536 s ~ 6.656 s
111	$2^{18} * T_{WDT}$	$1024 * T_{WDT}$	26.2144 s ~ 26.3168 s

Table 6–4 Watchdog Timeout Interval Selection

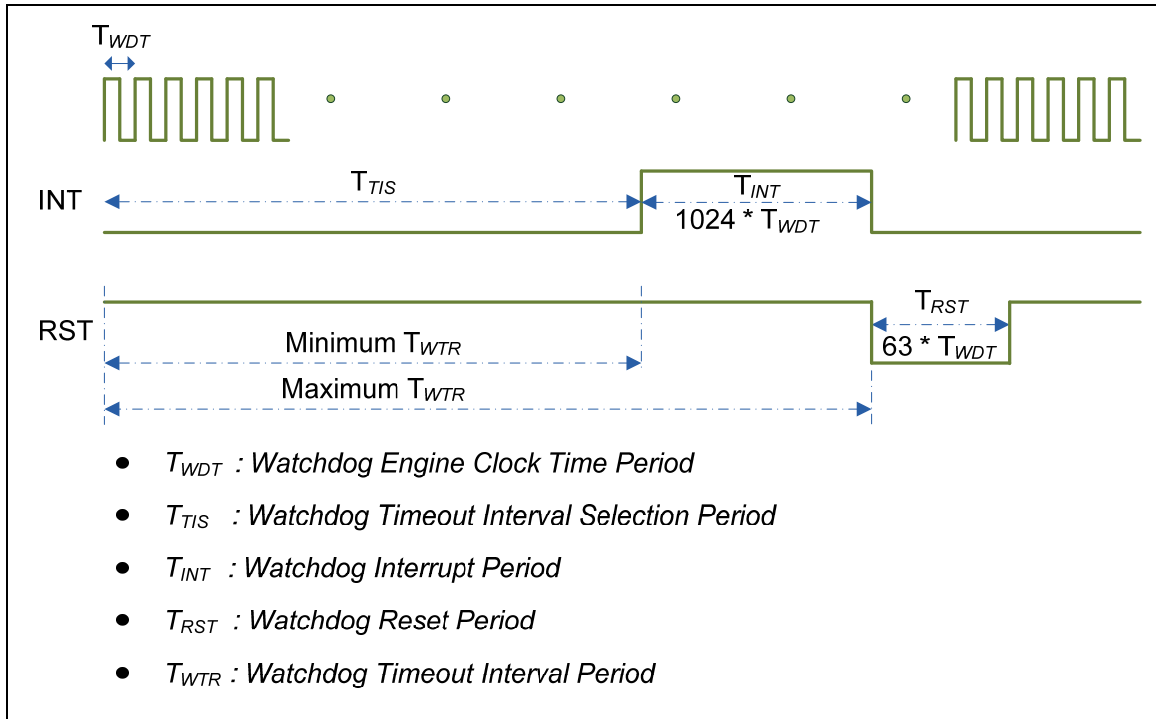

Figure 6–14 Timing of Interrupt and Reset Signal

6.9.2 Features

- 18-bit free running counter to avoid CPU from Watchdog timer reset before the delay time expires.
- Selectable time-out interval ($2^4 \sim 2^{18}$) and the time out interval is 1.6 ms \sim 26.21 s (if WDT_CLK = 10 kHz).
- Reset period = WDT_CLK * 63



6.10 UART Interface Controller

NuMicro M051™ series provides up to two channels of Universal Asynchronous Receiver/Transmitters (UART). UART0~1 performs Normal Speed UART, and support flow control function.

6.10.1 Overview

The Universal Asynchronous Receiver/Transmitter (UART) performs a serial-to-parallel conversion on data received from the peripheral, and a parallel-to-serial conversion on data transmitted from the CPU. The UART controller also supports IrDA SIR Function, and RS-485 mode functions. Each UART channel supports five types of interrupts including transmitter FIFO empty interrupt (INT_THRE), receiver threshold level reaching interrupt (INT_RDA), line status interrupt (parity error or framing error or break interrupt) (INT_RLS), receiver buffer time out interrupt (INT_TOUT), and MODEM/Wakeup status interrupt (INT_MODEM). Interrupt number 12 (vector number is 28) supports UART0 interrupt. Interrupt number 13 (vector number is 29) supports UART1 interrupt. Refer to Nested Vectored Interrupt Controller chapter for System Interrupt Map.

The UART0~1 are equipped 15-bytes transmitter FIFO (TX_FIFO) and 15-bytes receiver FIFO (RX_FIFO). The CPU can read the status of the UART at any time during the operation. The reported status information includes the type and condition of the transfer operations being performed by the UART, as well as 3 error conditions (parity error, framing error, and break interrupt) probably occur while receiving data. The UART includes a programmable baud rate generator that is capable of dividing clock input by divisors to produce the serial clock that transmitter and receiver need. The baud rate equation is $\text{Baud Rate} = \text{UART_CLK} / M * [\text{BRD} + 2]$, where M and BRD are defined in Baud Rate Divider Register (UA_BAUD). The Table 6–5 and Table 6–6 list the equations in the various conditions and the UART baud rate setting table.

Mode	DIV_X_EN	DIV_X_ONE	Divider X	BRD	Baud rate equation
0	0	0	B	A	$\text{UART_CLK} / [16 * (A+2)]$
1	1	0	B	A	$\text{UART_CLK} / [(B+1) * (A+2)]$, B must ≥ 8
2	1	1	Don't care	A	$\text{UART_CLK} / (A+2)$, A must ≥ 3

Table 6–5 UART Baud Rate Equation



System clock = 22.1184 MHz			
Baud rate	Mode0	Mode1	Mode2
921600	x	A=0,B=11	A=22
460800	A=1	A=1,B=15 A=2,B=11	A=46
230400	A=4	A=4,B=15 A=6,B=11	A=94
115200	A=10	A=10,B=15 A=14,B=11	A=190
57600	A=22	A=22,B=15 A=30,B=11	A=382
38400	A=34	A=62,B=8 A=46,B=11 A=34,B=15	A=574
19200	A=70	A=126,B=8 A=94,B=11 A=70,B=15	A=1150
9600	A=142	A=254,B=8 A=190,B=11 A=142,B=15	A=2302
4800	A=286	A=510,B=8 A=382,B=11 A=286,B=15	A=4606

Table 6–6 UART Baud Rate Setting Table

The UART0 and UART1 controllers support auto-flow control function that uses two low-level signals, /CTS (clear-to-send) and /RTS (request-to-send), to control the flow of data transfer between the UART and external devices (ex: Modem). When auto-flow is enabled, the UART is not allowed to receive data until the UART asserts /RTS to external device. When the number of bytes in the RX FIFO equals the value of RTS_TRI_LEV (UA_FCR [19:16]), the /RTS is de-asserted. The UART sends data out when UART controller detects /CTS is asserted from external device. If a valid asserted /CTS is not detected the UART controller will not send data out.

The UART controllers also provides Serial IrDA (SIR, Serial Infrared) function (User must set IrDA_EN (UA_FUN_SEL[1:0]) to enable IrDA function). The SIR specification defines a short-range infrared asynchronous serial transmission mode with one start bit, 8 data bits, and 1 stop bit. The maximum data rate is 115.2 Kbps (half duplex). The IrDA SIR block contains an IrDA SIR Protocol encoder/decoder. The IrDA SIR protocol is half-duplex only. So it cannot transmit and receive data at the same time. The IrDA SIR physical layer specifies a minimum 10ms transfer delay between transmission and reception. This delay feature must be implemented by software.

Another alternate function of UART controllers is RS-485 9 bit mode function, and direction control provided by RTS pin or can program GPIO (P0.3 for RTS0 and P0.1 for RTS 1) to implement the function by software. The RS-485 mode is selected by setting the UA_FUN_SEL register to select RS-485 function. The RS-485 driver control is implemented using the RTS control signal from an asynchronous serial port to enable the RS-485 driver. In RS-485 mode, many characteristics of the RX and TX are same as UART.

6.10.2 Features

- Full duplex, asynchronous communications
- Separate receive / transmit 15 bytes (UART0/UART1) entry FIFO for data payloads
- Support hardware auto flow control/flow control function (CTS, RTS) and programmable RTS flow control trigger level (UART0 and UART1 support)
- Programmable receiver buffer trigger level
- Support programmable baud-rate generator for each channel individually
- Support CTS wake up function (UART0 and UART1 support)
- Support 7 bit receiver buffer time out detection function
- Programmable transmitting data delay time between the last stop and the next start bit by setting UA_TOR [DLY] register
- Support break error, frame error, and parity error detect function
- Fully programmable serial-interface characteristics
- Programmable number of data bit, 5, 6, 7, 8 bit character
- Programmable parity bit, even, odd, no parity or stick parity bit generation and detection
- Programmable stop bit, 1, 1.5, or 2 stop bit generation
- Support IrDA SIR function mode
- Support for 3/16 bit duration for normal mode
- Support RS-485 function mode.
- Support RS-485 9bit mode
- Support hardware or software direct enable control provided by RTS pin

6.11 Analog-to-Digital Converter (ADC)

6.11.1 Overview

NuMicro M051™ series contain one 12-bit successive approximation analog-to-digital converters (SAR A/D converter) with 8 input channels. The A/D converter supports four operation modes: single, burst, single-cycle scan and continuous scan mode. The A/D converters can be started by software and external STADC/P3.2 pin.

6.11.2 Features

- Analog input voltage range: 0~AVDD (Max to 5.0V).
- 12-bit resolution and 10-bit accuracy is guaranteed.
- Up to 8 single-end analog input channels or 4 differential analog input channels.
- Maximum ADC clock frequency is 16 MHz.
- Up to 600k SPS conversion rate.
- Four operating modes
 - Single mode: A/D conversion is performed one time on a specified channel.
 - Single-cycle scan mode: A/D conversion is performed one cycle on all specified channels with the sequence from the lowest numbered channel to the highest numbered channel.
 - Continuous scan mode: A/D converter continuously performs Single-cycle scan mode until software stops A/D conversion.
 - Burst mode: A/D conversion will sample and convert the specified single channel and sequentially store in FIFO.
- An A/D conversion can be started by
 - Software Write 1 to ADST bit
 - External pin STADC
- Conversion results are held in data registers for each channel with valid and overrun indicators.
- Conversion result can be compared with specify value and user can select whether to generate an interrupt when conversion result matches the compare register setting.



- Channel 7 supports 2 input sources: external analog voltage and internal fixed bandgap voltage.
- Support Self-calibration to minimize conversion error.

6.12 External Bus Interface (EBI)

6.12.1 Overview

NuMicro M051™ series equips an external bus interface (EBI) for external device used.

To save the connections between external device and this chip, EBI support address bus and data bus multiplex mode. And, address latch enable (ALE) signal supported differentiate the address and data cycle.

6.12.2 Features

External Bus Interface has the following functions:

1. External devices with max. 64K-byte size (8 bit data width)/128K-byte (16 bit data width) supported
2. Variable external bus base clock (MCLK) supported
3. 8 bit or 16 bit data width supported
4. Variable data access time (tACC), address latch enable time (tALE) and address hold time (tAHD) supported
5. Address bus and data bus multiplex mode supported to save the address pins
6. Configurable idle cycle supported for different access condition: Write command finish (W2X), Read-to-Read (R2R)

6.13 Flash Memory Controller (FMC)

6.13.1 Overview

M052/M054 equips with 16K/8K bytes on chip embedded Flash EEPROM for application program memory (APROM) that can be updated through ISP/IAP procedure. In System Programming (ISP) function enables user to update program memory when chip is soldered on PCB. After chip power on Cortex-M0 CPU fetches code from APROM or LDROM decided by boot select (CBS) in Config0. By the way, NuMicro M051™ series also provide additional 4K bytes DATA Flash for user to store some application depended data before chip power off.

6.13.2 Features

- Run up to 50 MHz with zero wait state for continuous address read access
- 16/8KB application program memory (APROM)
- 4KB in system programming (ISP) loader program memory (LDROM)
- Fixed 4KB data flash with 512 bytes page erase unit
- In System Program (ISP)/In Application Program (IAP) to update on chip Flash EPROM
- In Circuit Program (ICP) via serial wire debug interface (SWD)

7 TYPICAL APPLICATION CIRCUIT

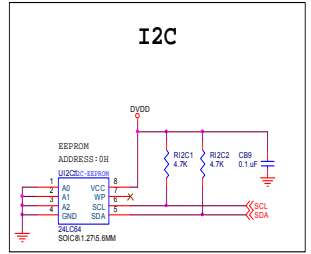
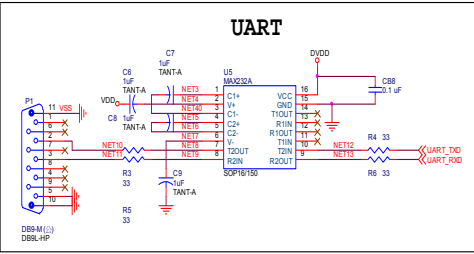
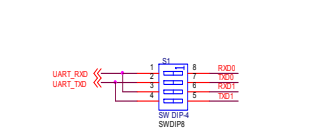
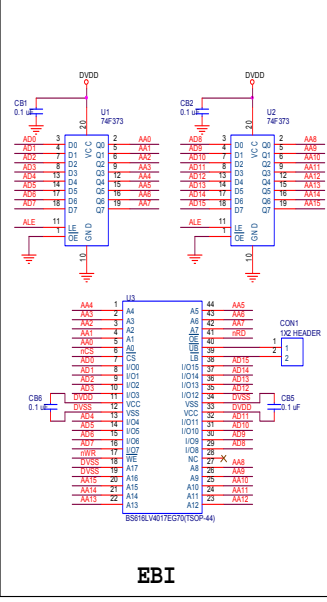
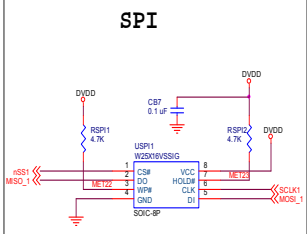
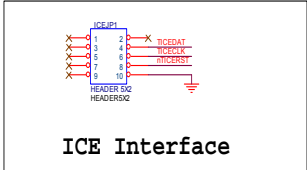
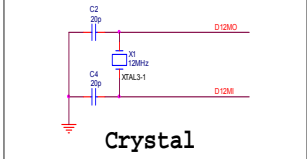
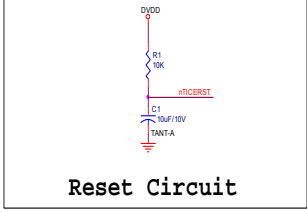
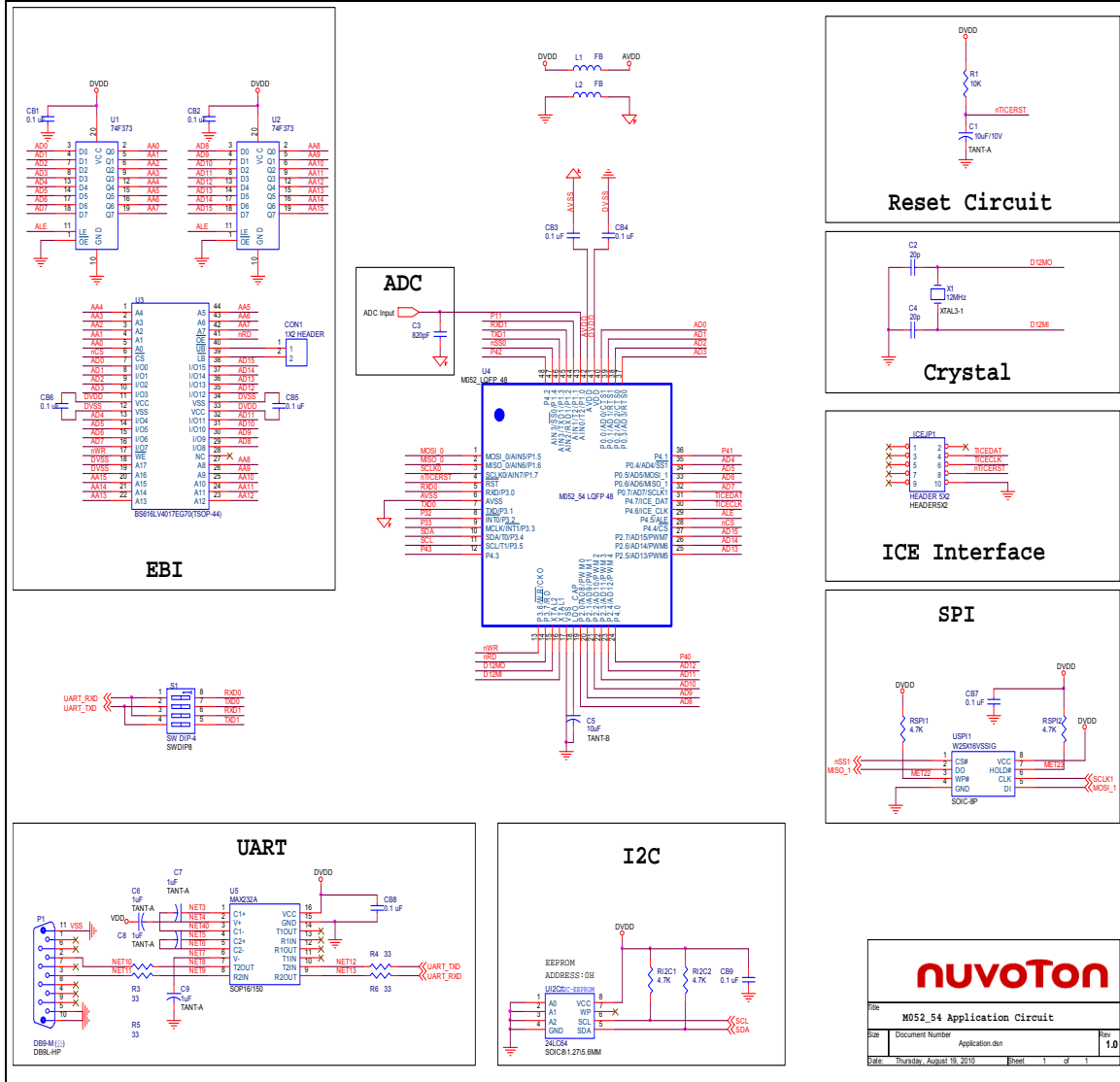

nuvoTon	
M052_54 Application Circuit	
Size: Document Number	Application.dsn
Size: Thursday, August 19, 2010	Sheet 1 of 1
	Rev 1.0

8 ELECTRICAL CHARACTERISTICS

8.1 Absolute Maximum Ratings

SYMBOL	PARAMETER	MIN	MAX	UNIT
DC Power Supply	VDD-VSS	-0.3	+7.0	V
Input Voltage	VIN	VSS-0.3	VDD+0.3	V
Oscillator Frequency	1/t _{CLCL}	0	40	MHz
Operating Temperature	TA	-40	+85	°C
Storage Temperature	TST	-55	+150	°C
Maximum Current into V _{DD}		-	120	mA
Maximum Current out of V _{SS}			120	mA
Maximum Current sunk by a I/O pin			35	mA
Maximum Current sourced by a I/O pin			35	mA
Maximum Current sunk by total I/O pins			100	mA
Maximum Current sourced by total I/O pins			100	mA

Note: Exposure to conditions beyond those listed under absolute maximum ratings may adversely affect the life and reliability of the device.



8.2 DC Electrical Characteristics

(V_{DD}-V_{SS}=2.5~5.5V, T_A = 25°C, F_{OSC} = 50 MHz unless otherwise specified.)

PARAMETER	SYM.	SPECIFICATION				TEST CONDITIONS
		MIN.	TYP.	MAX.	UNIT	
Operation voltage	V _{DD}	2.5		5.5	V	V _{DD} = 2.5V ~ 5.5V up to 50 MHz
Power Ground	V _{SS} AV _{SS}	-0.3			V	
LDO Output Voltage	V _{LDO}	-10%	2.45	+10%	V	V _{DD} > 2.7V
Band Gap Analog Input	V _{BG}	-5%	1.26	+5%	V	V _{DD} = 2.5V ~ 5.5V
Analog Operating Voltage	AV _{DD}	0		V _{DD}	V	
Operating Current Normal Run Mode @ 50 MHz	I _{DD1}		32		mA	V _{DD} = 5.5V@50 MHz, enable all IP and PLL, XTAL=12 MHz
	I _{DD2}		24		mA	V _{DD} = 5.5V@50 MHz, disable all IP and enable PLL, XTAL=12 MHz
	I _{DD3}		31		mA	V _{DD} = 3V@50 MHz, enable all IP and PLL, XTAL=12 MHz
	I _{DD4}		23		mA	V _{DD} = 3V@50 MHz, disable all IP and enable PLL, XTAL=12 MHz
Operating Current Normal Run Mode @ 12 MHz	I _{DD5}		17		mA	V _{DD} = 5.5V@12MHz, enable all IP and disable PLL, XTAL=12 MHz
	I _{DD6}		14		mA	V _{DD} = 5.5V@12 MHz, disable all IP and disable PLL, XTAL=12 MHz
	I _{DD7}		16		mA	V _{DD} = 3V@12 MHz, enable all IP and disable PLL, XTAL=12 MHz
	I _{DD8}		13		mA	V _{DD} = 3V@12 MHz, disable all IP and disable PLL, XTAL=12 MHz
Operating Current Normal Run Mode @ 4 MHz	I _{DD9}		12		mA	V _{DD} = 5.5V@4 MHz, enable all IP and disable PLL, XTAL=4MHz
	I _{DD10}		10		mA	V _{DD} = 5.5V@4 MHz, disable all IP and disable PLL, XTAL=4MHz
	I _{DD11}		10		mA	V _{DD} = 3V@4 MHz, enable all IP and disable PLL, XTAL=4MHz
	I _{DD12}		9		mA	V _{DD} = 3V@4 MHz, disable all IP and disable PLL, XTAL=4 MHz
Operating Current	I _{IDLE1}		19		mA	V _{DD} = 5.5V@50 MHz, enable all IP and PLL, XTAL=12 MHz



Idle Mode @ 50 MHz	I_{IDLE2}		11		mA	$V_{DD}=5.5V@50$ MHz, disable all IP and enable PLL, XTAL=12 MHz
	I_{IDLE3}		18		mA	$V_{DD} = 3V@50$ MHz, enable all IP and PLL, XTAL=12 MHz
	I_{IDLE4}		10		mA	$V_{DD} = 3V@50$ MHz, disable all IP and enable PLL, XTAL=12 MHz
Operating Current Idle Mode @ 12 MHz	I_{IDLE5}		10		mA	$V_{DD} = 5.5V@12$ MHz, enable all IP and disable PLL, XTAL=12 MHz
	I_{IDLE6}		7		mA	$V_{DD} = 5.5V@12$ MHz, disable all IP and disable PLL, XTAL=12 MHz
	I_{IDLE7}		9		mA	$V_{DD} = 3V@12$ MHz, enable all IP and disable PLL, XTAL=12 MHz
	I_{IDLE8}		6		mA	$V_{DD} = 3V@12$ MHz, disable all IP and disable PLL, XTAL=12 MHz
Operating Current Idle Mode @ 4 MHz	I_{IDLE9}		5		mA	$V_{DD} = 5.5V@4$ MHz, enable all IP and disable PLL, XTAL=4 MHz
	I_{IDLE10}		4		mA	$V_{DD} = 5.5V@4$ MHz, disable all IP and disable PLL, XTAL=4 MHz
	I_{IDLE11}		4		mA	$V_{DD} = 3V@4$ MHz, enable all IP and disable PLL, XTAL=4 MHz
	I_{IDLE12}		3		mA	$V_{DD} = 3V@4$ MHz, disable all IP and disable PLL, XTAL=4 MHz
Standby Current Power-down Mode (Deep Sleep Mode)	I_{PWD1}		15		μA	$V_{DD} = 5.5V$, No load @ Disable BOV function
	I_{PWD2}		11		μA	$V_{DD} = 3.0V$, No load @ Disable BOV function
Input Current P0/1/2/3/4 (Quasi-bidirectional mode)	I_{IN1}		-50	-60	μA	$V_{DD} = 5.5V$, $V_{IN} = 0.4V$
Input Leakage Current P0/1/2/3/4	I_{LK}	-2	-	+2	μA	$V_{DD} = 5.5V$, $0 < V_{IN} < V_{DD}$
Logic 1 to 0 Transition Current P0/1/2/3/4 (Quasi-bidirectional mode)	$I_{TL}^{[3]}$	-650	-	-200	μA	$V_{DD} = 5.5V$, $V_{IN} < 2.0V$
Input Low Voltage P0/1/2/3/4 (TTL input)	V_{IL1}	-0.3	-	0.8	V	$V_{DD} = 4.5V$
		-0.3	-	0.6		$V_{DD} = 2.5V$
Input High Voltage P0/1/2/3/4 (TTL input)	V_{IH1}	2.0	-	$V_{DD} + 0.2$	V	$V_{DD} = 5.5V$
		1.5	-	$V_{DD} + 0.2$		$V_{DD} = 3.0V$
Input Low Voltage XT1 ^[2]	V_{IL3}	0	-	0.8	V	$V_{DD} = 4.5V$
		0	-	0.4		$V_{DD} = 3.0V$
Input High Voltage XT1 ^[2]	V_{IH3}	3.5	-	$V_{DD} + 0.2$	V	$V_{DD} = 5.5V$
		2.4	-	$V_{DD} + 0.2$		$V_{DD} = 3.0V$
Negative going threshold (Schmitt input), /RST	V_{ILS}	-0.5	-	$0.3V_{DD}$	V	



Positive going threshold (Schmitt input), /RST	V_{IHS}	$0.7V_{DD}$	-	$V_{DD}+0.5$	V	
Internal /RST pin pull up resistor	R_{RST}	40		150	K Ω	
Negative going threshold (Schmitt input), P0/1/2/3/4	V_{ILS}	-0.5	-	$0.2V_{DD}$	V	
Positive going threshold (Schmitt input), P0/1/2/3/4	V_{IHS}	$0.4V_{DD}$	-	$V_{DD}+0.5$	V	
Source Current P0/1/2/3/4 (Quasi-bidirectional Mode)	I_{SR11}	-300	-370	-450	μ A	$V_{DD} = 4.5V, V_S = 2.4V$
	I_{SR12}	-50	-70	-90	μ A	$V_{DD} = 2.7V, V_S = 2.2V$
	I_{SR12}	-40	-60	-80	μ A	$V_{DD} = 2.5V, V_S = 2.0V$
Source Current P0/1/2/3/4 (Push-pull Mode)	I_{SR21}	-20	-24	-28	mA	$V_{DD} = 4.5V, V_S = 2.4V$
	I_{SR22}	-4	-6	-8	mA	$V_{DD} = 2.7V, V_S = 2.2V$
	I_{SR22}	-3	-5	-7	mA	$V_{DD} = 2.5V, V_S = 2.0V$
Sink Current P0/1/2/3/4 (Quasi-bidirectional and Push-pull Mode)	I_{SK1}	10	16	20	mA	$V_{DD} = 4.5V, V_S = 0.45V$
	I_{SK1}	7	10	13	mA	$V_{DD} = 2.7V, V_S = 0.45V$
	I_{SK1}	6	9	12	mA	$V_{DD} = 2.5V, V_S = 0.45V$
Brownout voltage with BOV_VL [1:0] =00b	$V_{BO2.2}$	2.1	2.2	2.3	V	
Brownout voltage with BOV_VL [1:0] =01b	$V_{BO2.7}$	2.6	2.7	2.8	V	
Brownout voltage with BOV_VL [1:0] =10b	$V_{BO3.8}$	3.7	3.8	3.9	V	
Brownout voltage with BOV_VL [1:0] =11b	$V_{BO4.5}$	4.4	4.5	4.6	V	
Hysteresis range of BOD voltage	V_{BH}	30	-	150	mV	$V_{DD} = 2.5V\sim 5.5V$

Notes:

- /RST pin is a Schmitt trigger input.
- XTAL1 is a CMOS input.
- Pins of P0, P1, P2, P3 and P4 can source a transition current when they are being externally driven from 1 to 0. In the condition of $V_{DD}=5.5V$, the transition current reaches its maximum value when V_{in} approximates to 2V.



8.3 AC Electrical Characteristics

8.3.1 External Crystal

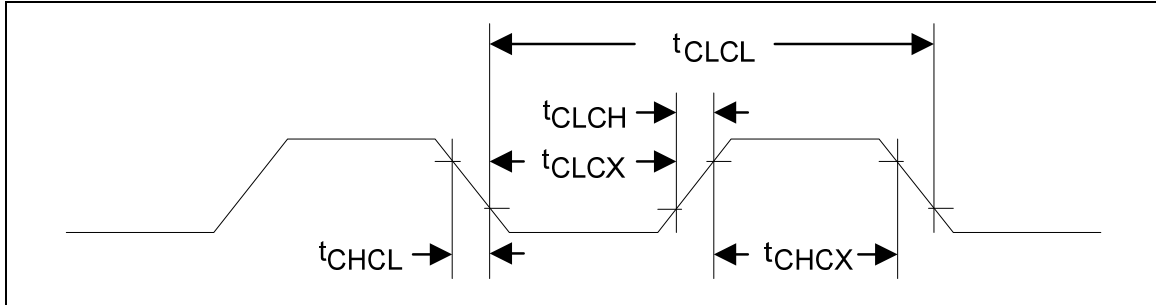

Note: Duty cycle is 50%.

PARAMETER	SYMBOL	MIN.	TYP.	MAX.	UNITS	CONDITION
Clock High Time	t_{CHCX}	20	-	125	nS	
Clock Low Time	t_{CLCX}	20	-	125	nS	
Clock Rise Time	t_{CLCH}	-	-	10	nS	
Clock Fall Time	t_{CHCL}	-	-	10	nS	

8.3.2 External Oscillator

PARAMETER	CONDITION	MIN.	TYP.	MAX.	UNIT
Input clock frequency	External crystal	4	12	24	MHz
Temperature	-	-40	-	85	°C
V_{DD}	-	2.5	5	5.5	V
Operating current	12 MHz@ $V_{DD} = 5V$	-	5	-	mA

8.3.3 Typical Crystal Application Circuits

CRYSTAL	C1	C2
4 MHz ~ 24 MHz	Optional (Depend on crystal specification)	

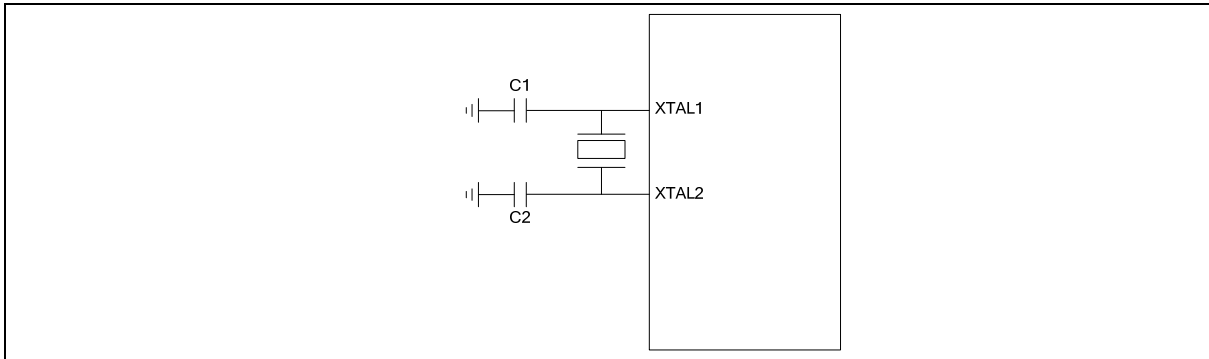

Figure 8-1 Typical Crystal Application Circuit

8.3.4 Internal 22.1184 MHz RC Oscillator

PARAMETER	CONDITION	MIN.	TYP.	MAX.	UNIT
Supply voltage ^[1]	-	2.5	-	5.5	V
Center Frequency	-	-	22.1184	-	MHz
Calibrated Internal Oscillator Frequency	+25 C; V _{DD} =5V	-1	-	+1	%
	-40 C~+85 C; V _{DD} =2.5V~5.5V	-3	-	+3	%
Accuracy of Un-calibrated Internal Oscillator Frequency	-40 C~+85 C; V _{DD} =2.5V~5.5V	-25	-	+25	%
Operating current	V _{DD} =5V	-	500	-	μA

8.3.5 Internal 10kHz RC Oscillator

PARAMETER	CONDITION	MIN.	TYP.	MAX.	UNIT
Supply voltage ^[1]	-	2.5	-	5.5	V
Center Frequency	-	-	10	-	kHz
Calibrated Internal Oscillator Frequency	+25 C; V _{DD} =5V	-30	-	+30	%
	-40 C~+85 C; V _{DD} =2.5V~5.5V	-50	-	+50	%
Operating current	V _{DD} =5V	-	5	-	μA

Notes:

1. Internal operation voltage comes from LDO.

8.4 Analog Characteristics

8.4.1 Specification of 600kHz sps 12-bit SARADC

PARAMETER	SYM.	MIN.	TYP.	MAX.	UNIT
Resolution	-	-	-	12	Bit
Differential nonlinearity error	DNL	-	±1.2	-	LSB
Integral nonlinearity error	INL	-	±1.5	-	LSB
Offset error	EO	-	+4	10	LSB
Gain error (Transfer gain)	EG	-	+7	1.005	-
Monotonic	-	Guaranteed			-
ADC clock frequency	FADC	-	-	20	MHz
Calibration time	TCAL	-	127	-	Clock
Sample time	TS	-	7	-	Clock
Conversion time	TADC	-	13	-	Clock
Sample rate	FS	-	-	600	k sps
Supply voltage	V _{LDO}	-	2.5	-	V
	V _{ADD}	3	-	5.5	V
Supply current (Avg.)	IDD	-	0.5	-	mA
	IDDA	-	1.5	-	mA
Input voltage range	V _{IN}	0	-	AVDD	V
Capacitance	C _{IN}	-	5	-	pF

8.4.2 Specification of LDO & Power management

PARAMETER	MIN	TYP	MAX	UNIT	NOTE
Input Voltage	2.7	5	5.5	V	V _{DD} input voltage
Output Voltage (bypass=0)	-10%	2.45	+10%	V	LDO output voltage
Output Voltage (bypass=1)	-10%	Input Voltage	+10%	V	Input Voltage < 2.7V
Quiescent Current	-	100	-	uA	



(PD=0, bypass=0)					
Quiescent Current (PD=1, bypass=0)	-	5	-	uA	
Quiescent Current (PD=1, bypass=1)	-	5	-	uA	
Iload (PD=0)	-	-	100	mA	
Iload (PD=1)	-	-	100	uA	
Cbp	-	1u	-	F	Resr=1ohm
Cload	-	250p	-	F	

Note:

1. It is recommended that a 10uF or higher capacitor and a 100nF bypass capacitor are connected between VDD and the closest VSS pin of the device.
2. For ensuring power stability, a 4.7uF or higher capacitor must be connected between LDO pin and the closest VSS pin of the device. Also a 100nF bypass capacitor between LDO and VSS help suppressing output noise.

8.4.3 Specification of Low Voltage Reset

PARAMETER	CONDITION	MIN.	TYP.	MAX.	UNIT
Operation voltage	-	1.7	-	5.5	V
Quiescent current	VDD5V=5.5V	-	-	5	uA
Threshold voltage	Temperature=25°	1.7	2.0	2.3	V
	Temperature=-40°	-	2.4	-	V
	Temperature=85°	-	1.6	-	V
Hysteresis	-	0	0	0	V

8.4.4 Specification of Brownout Detector

Parameter	Condition	Min.	Typ.	Max.	Unit
Operation voltage	-	2.5	-	5.5	V
Quiescent current	AVDD=5.5V	-	-	125	μA



Temperature	-	-40	25	85	°C
Brownout voltage	BOV_VL[1:0]=11	4.4	4.5	4.6	V
	BOV_VL [1:0]=10	3.7	3.8	3.9	V
	BOV_VL [1:0]=01	2.6	2.7	2.8	V
	BOV_VL [1:0]=00	2.1	2.2	2.3	V
Hysteresis	-	30m	-	150m	V

8.4.5 Specification of Power-On Reset (5V)

Parameter	Condition	Min.	Typ.	Max.	Unit
Reset voltage	V+	-	2	-	V
Quiescent current	Vin>reset voltage	-	1	-	nA



8.5 SPI Dynamic characteristics

Symbol	Parameter	Min	Typ	Max	Unit
SPI master mode (VDD = 4.5V ~ 5.5V, 30pF loading Capacitor)					
t_{DS}	Data setup time	26	-	-	ns
t_{DH}	Data hold time	0	-	-	ns
t_V	Data output valid time	-	-	10	ns
SPI master mode (VDD = 3.0V ~ 3.6V, 30pF loading Capacitor)					
t_{DS}	Data setup time	39	-	-	ns
t_{DH}	Data hold time	0	-	-	ns
t_V	Data output valid time	-	-	16	ns
SPI slave mode (VDD = 4.5V ~ 5.5V, 30pF loading Capacitor)					
t_{DS}	Data setup time	0	-	-	ns
t_{DH}	Data hold time	$2 \cdot PCLK + 4$	-	-	ns
t_V	Data output valid time	-	-	$2 \cdot PCLK + 40$	ns
SPI slave mode (VDD = 3.0V ~ 3.6V, 30pF loading Capacitor)					
t_{DS}	Data setup time	0	-	-	ns
t_{DH}	Data hold time	$2 \cdot PCLK + 5$	-	-	ns
t_V	Data output valid time	-	-	$2 \cdot PCLK + 50$	ns

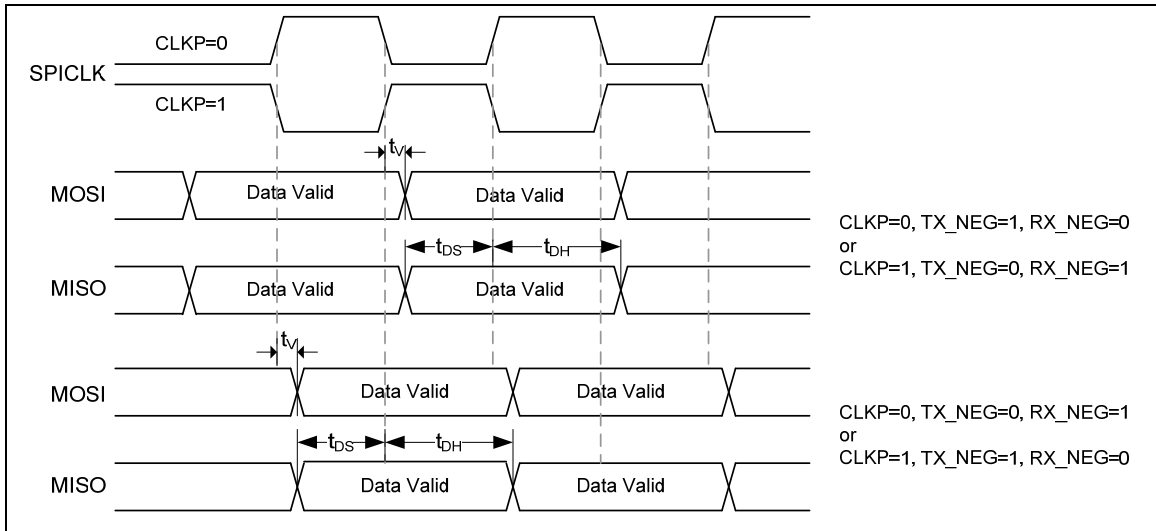

Figure 8–2 SPI Master timing

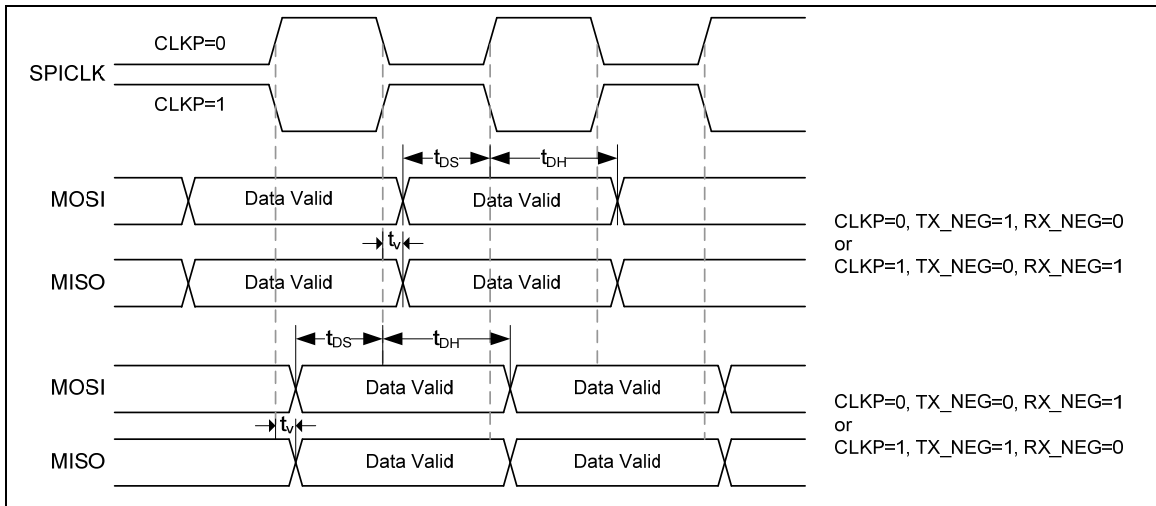
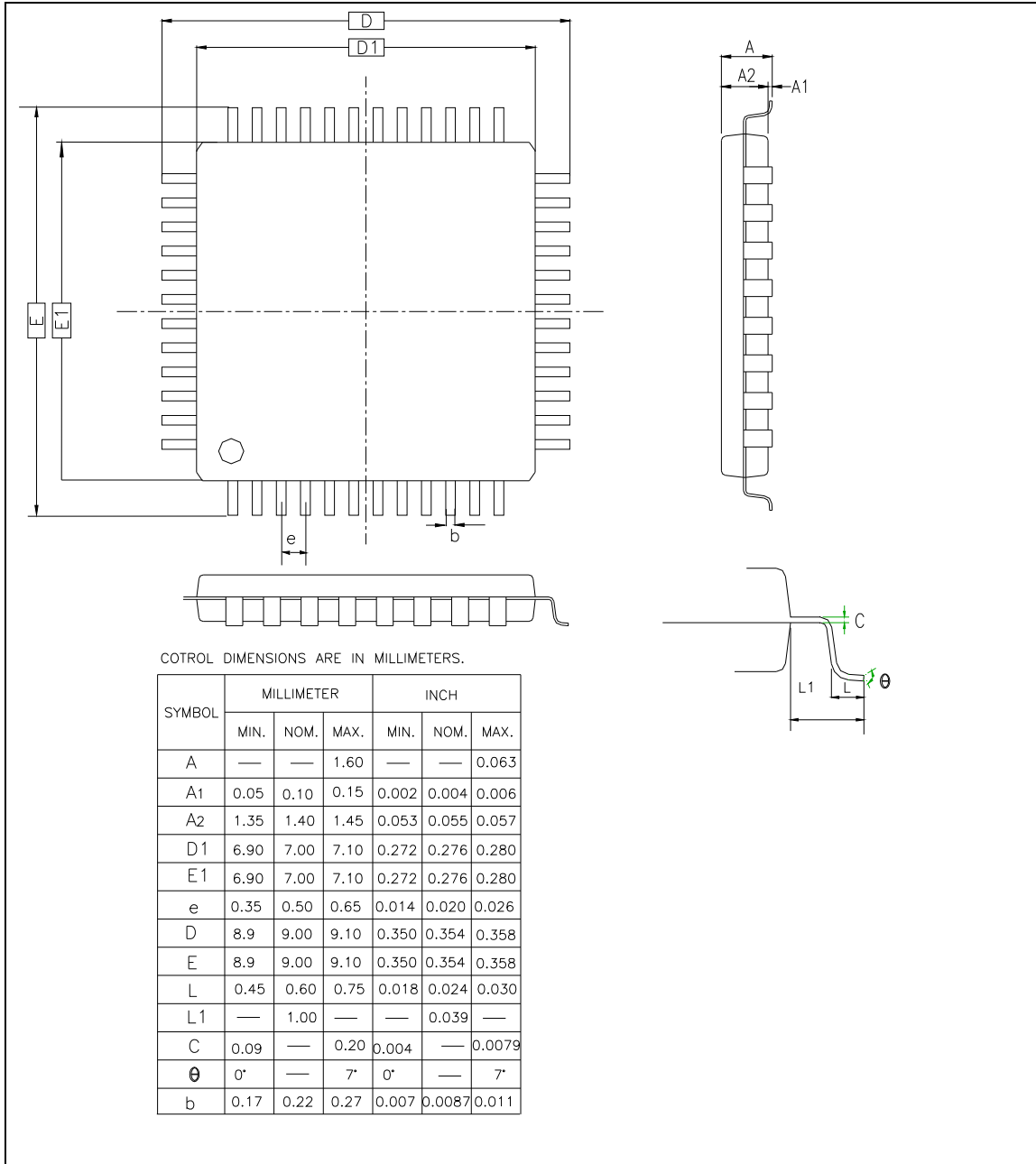

Figure 8–3 SPI Slave timing

9 PACKAGE DIMENSIONS

9.1 LQFP-48 (7x7x1.4mm² Footprint 2.0mm)



9.2 QFN-33 (5X5 mm², Thickness 0.8mm, Pitch 0.5 mm)

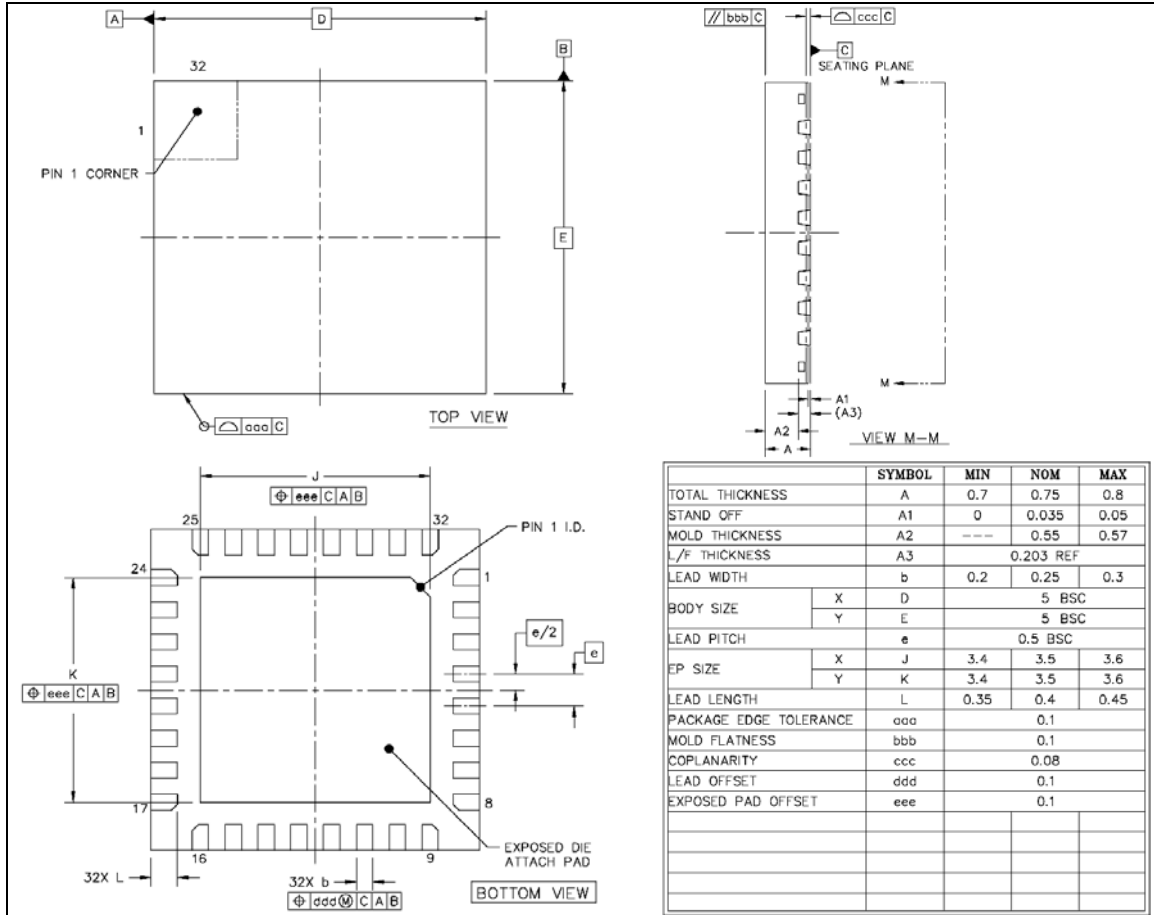

10 REVISION HISTORY

VERSION	DATE	PAGE	DESCRIPTION
V1.0	Mar 15, 2011	-	Initial issued



Important Notice

Nuvoton Products are neither intended nor warranted for usage in systems or equipment, any malfunction or failure of which may cause loss of human life, bodily injury or severe property damage. Such applications are deemed, "Insecure Usage".

Insecure usage includes, but is not limited to: equipment for surgical implementation, atomic energy control instruments, airplane or spaceship instruments, the control or operation of dynamic, brake or safety systems designed for vehicular use, traffic signal instruments, all types of safety devices, and other applications intended to support or sustain life.

All Insecure Usage shall be made at customer's risk, and in the event that third parties lay claims to Nuvoton as a result of customer's Insecure Usage, customer shall indemnify the damages and liabilities thus incurred by Nuvoton.

*Please note that all data and specifications are subject to change without notice.
All the trademarks of products and companies mentioned in this datasheet belong to their respective owners.*