



**SANYO Semiconductors**

# DATA SHEET



## LV1117N/NV

Bi-CMOS IC

### Surround Processor ICs for Electronic Volume Control

#### Overview

The LV1117N/NV are sound processor ICs developed for use in TV sets.

They incorporate the surround processing functions including (AViSS), pseudo stereo function, (L+R) output, and the major functional blocks of an electronic volume control IC.

#### Features

- Input function SW (4ch stereo inputs [L, R]).
  - Line out (through output).
  - Input gain control (-6dB, -4dB, 0dB, 4dB, 6dB: 5 positions).
  - AViSS (ON/OFF/6-stage level control).
  - Tone control (BASS:  $\pm 20$ dB, TREBLE:  $\pm 18$ dB [in 2dB steps]).
  - Volume control (0dB to -14dB: 1dB step/-14dB to -80dB: 2dB steps/ $-\infty$ =-82dB).
  - Balance control.
  - Through mode/Mute mode.
  - Pseudo stereo function (ON/OFF/MONO).
  - L+R output with LPF (Mute + 7-stage level control: 8 positions).
  - I<sup>2</sup>C bus control.
  - Parallel output ports (4pin).
- \* Initial gain of L+R AMP can be controlled by the resistance value of external resistor.

■ Any and all SANYO Semiconductor Co.,Ltd. products described or contained herein are, with regard to "standard application", intended for the use as general electronics equipment (home appliances, AV equipment, communication device, office equipment, industrial equipment etc.). The products mentioned herein shall not be intended for use for any "special application" (medical equipment whose purpose is to sustain life, aerospace instrument, nuclear control device, burning appliances, transportation machine, traffic signal system, safety equipment etc.) that shall require extremely high level of reliability and can directly threaten human lives in case of failure or malfunction of the product or may cause harm to human bodies, nor shall they grant any guarantee thereof. If you should intend to use our products for applications outside the standard applications of our customer who is considering such use and/or outside the scope of our intended standard applications, please consult with us prior to the intended use. If there is no consultation or inquiry before the intended use, our customer shall be solely responsible for the use.

■ Specifications of any and all SANYO Semiconductor Co.,Ltd. products described or contained herein stipulate the performance, characteristics, and functions of the described products in the independent state, and are not guarantees of the performance, characteristics, and functions of the described products as mounted in the customer's products or equipment. To verify symptoms and states that cannot be evaluated in an independent device, the customer should always evaluate and test devices mounted in the customer's products or equipment.

**SANYO Semiconductor Co., Ltd.**

TOKYO OFFICE Tokyo Bldg., 1-10, 1 Chome, Ueno, Taito-ku, TOKYO, 110-8534 JAPAN

# LV1117N/1117NV

## Specifications

### Maximum Ratings at Ta = 25°C

Parameter	Symbol	Conditions	Ratings	Unit
Maximum supply voltage	V <sub>CC</sub> max		10.5	V
Allowable power dissipation 1	Pd max1	Ta ≤ 70°C, DIP	700	mW
Allowable power dissipation 2	Pd max2	Ta ≤ 70°C *, SSOP	700	mW
Operating temperature	Topr		-25 to +70	°C
Storage temperature	Tstg		-40 to +125	°C

Note \*: Mounted on a specified board: 114.3mm×76.1mm×1.6mm, glass epoxy board

### Operating Conditions at Ta = 25°C

Parameter	Symbol	Conditions	Ratings	Unit
Recommended supply voltage	V <sub>CC</sub>		9.0	V
Operating supply voltage 1	V <sub>CC</sub> opg1	DIP	5.0 to 10.0	V
Operating supply voltage 2	V <sub>CC</sub> opg2	SSOP	5.0 to 9.0	V
<b>Control data</b>				
"H" level voltage	V <sub>IH</sub>		2.0 to 5.5	V
"L" level voltage	V <sub>IL</sub>		0.0 to 1.0	V
Pulse width	t <sub>pw</sub>		1.0	μs
Hold time	t <sub>hold</sub>		1.0	μs
Operating frequency	f <sub>opg</sub>		100	kHz

### Electrical Characteristics at Ta = 25°C, V<sub>CC</sub> = 9.0V, fin = 1kHz, V<sub>IN</sub> = 300mVrms = 0dB, R<sub>L</sub> = 10kΩ (Input=L/Rch-A, Output=L/R-VROUT)

Parameter	Symbol	Conditions	Ratings			Unit
			min	typ	max	
Quiescent current	I <sub>CCO</sub>			48		mA
<b>Total through (Total through mode, Volume control: 0dB)</b>						
Voltage gain	V <sub>G<sub>T</sub></sub>		-1.6	-0.6	+0.6	dB
Maximum output voltage	V <sub>O<sub>T</sub></sub>	THD=1%	2.0	2.6		Vrms
Total harmonic distortion	THD <sub>T</sub>	DIN AUDIO		0.03	0.1	%
Output noise voltage	V <sub>N<sub>O<sub>T</sub></sub></sub>	DIN AUDIO		-93	-85	dBV
Cross talk	CT <sub>T</sub>	DIN AUDIO	85	93		dB
<b>Matrix through (Matrix mode, Input gain: 0dB, Volume control: 0dB)</b>						
Voltage gain	V <sub>G<sub>F</sub></sub>		-1.7	-0.7	+0.7	dB
Maximum output voltage	V <sub>O<sub>M</sub></sub>	THD=1%	1.5	2.0		Vrms
Total harmonic distortion	THD <sub>M</sub>	DIN AUDIO		0.04	0.1	%
Output noise voltage	V <sub>N<sub>O<sub>M</sub></sub></sub>	DIN AUDIO		-92	-83	dBV
Cross talk	CT <sub>M</sub>	DIN AUDIO	85	91		dB
<b>MONO mode (MONO mode, Input gain: 0dB, Volume control: 0dB)</b>						
Maximum output voltage	V <sub>O<sub>S</sub></sub>	THD=1%	1.5	2.0		Vrms
Total harmonic distortion	THD <sub>S</sub>	DIN AUDIO		0.04	0.5	%
Output noise voltage	V <sub>N<sub>O<sub>S</sub></sub></sub>	DIN AUDIO		-92	-82	dBV
<b>Surround (Surround mode-A, Input gain: 0dB, Volume control: 0dB)</b>						
Maximum output voltage	V <sub>O<sub>S</sub></sub>	THD=1%	1.5	2.0		Vrms
Total harmonic distortion	THD <sub>S</sub>	DIN AUDIO		0.2	0.5	%
Output noise voltage	V <sub>N<sub>O<sub>S</sub></sub></sub>	DIN AUDIO		-90	-81	dBV
<b>Pseudo stereo (Pseudo stereo mode, Input gain: 0dB, Volume control: 0dB)</b>						
Maximum output voltage	V <sub>O<sub>S</sub></sub>	THD=1%	1.5	2.0		Vrms
Total harmonic distortion	THD <sub>S</sub>	DIN AUDIO		0.07	0.5	%
Output noise voltage	V <sub>N<sub>O<sub>S</sub></sub></sub>	DIN AUDIO		-90	-82	dBV

Continued on next page.

# LV1117N/1117NV

Continued from preceding page.

Parameter	Symbol	Conditions	Ratings			Unit
			min	typ	max	
<b>Bass band EQ (Matrix through mode, Input gain: 0dB, Volume control: 0dB)</b>						
Control Range	$Geq_B$	Max. Boost/Cut	$\pm 17$	$\pm 20$	$\pm 23$	dB
Step resolution	$Estep_B$		1.0	2.0	3.0	dB
<b>Treble band EQ (Matrix through mode, Input gain: 0dB, Volume control: 0dB)</b>						
Control Range	$Geq_T$	Max. Boost/Cut	$\pm 15$	$\pm 18$	$\pm 21$	dB
Step resolution	$Estep_T$		1.0	2.0	3.0	dB
<b>L+R output (Output=L+R-OUT, Step=0dB, L+R_Step=Step4)</b>						
Voltage gain	$VG_F$		-2.3	-1.3	-0.3	dB
Maximum output voltage	VOF	THD=1%	2.0	2.5		Vrms
Total harmonic distortion	THD <sub>F</sub>	DIN AUDIO		0.03	0.1	%
Output noise voltage	VNO <sub>F</sub>	DIN AUDIO		-99	-85	dBV
<b>Port Output (20/21/22/23pin)</b>						
Low level output voltage	$V_{OL}$	$I_O=1mA$			0.3	V
Port output sink Current	$I_O$				1.0	mA

Note: The output wave form becomes big depending on the surround or tone control setting. Please make sure the output waveform is not distorted. If the waveform is distorted, reduce the gain setting of surround, tone control, or input signal level.

## Package Dimensions

unit : mm (typ)

3025C

[LV1117N]

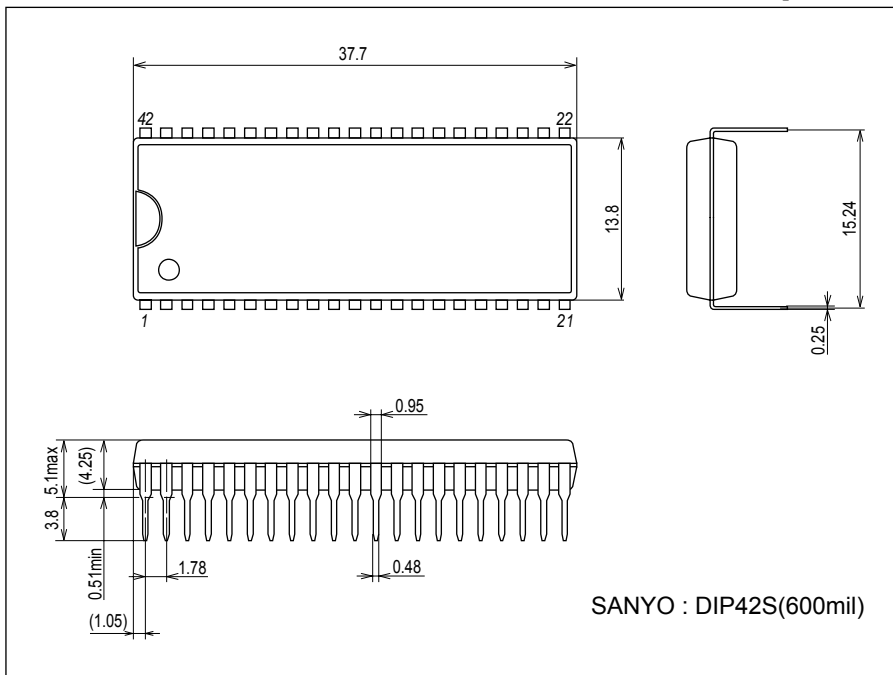

# LV1117N/1117NV

## Package Dimensions

unit : mm (typ)

3277

[LV1117NV]

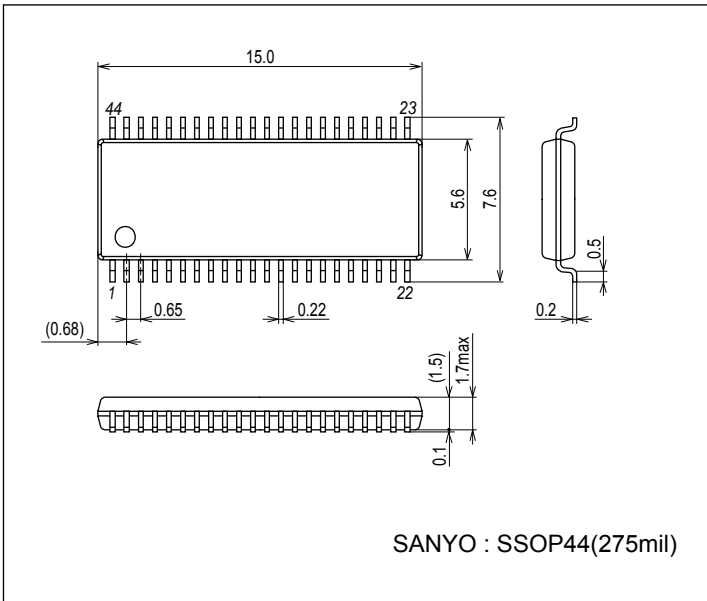

Block Diagram [LV1117N]

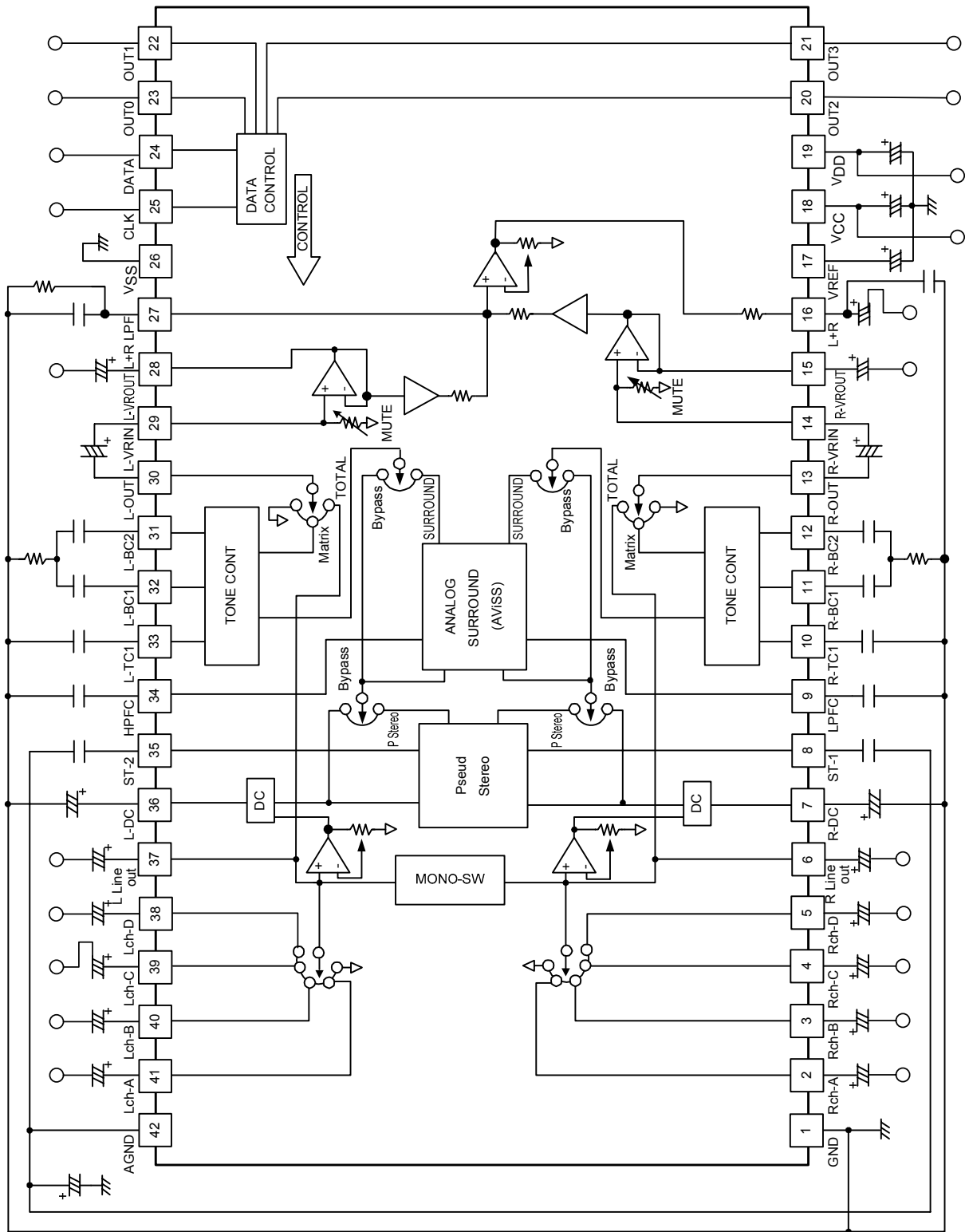

# LV1117N/1117NV

## Block Diagram [LV1117NV]

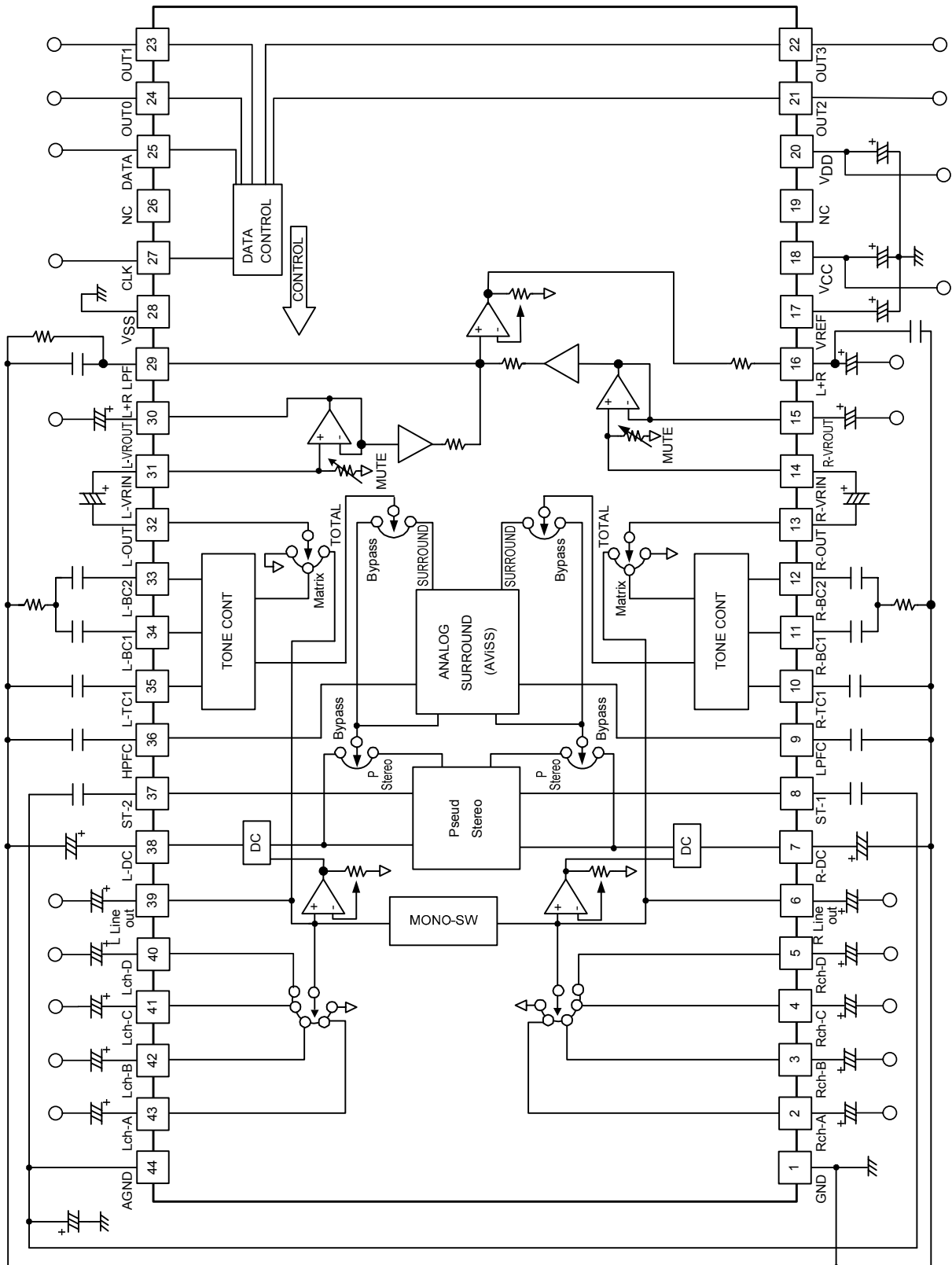

I<sup>2</sup>C BUS Control Signal

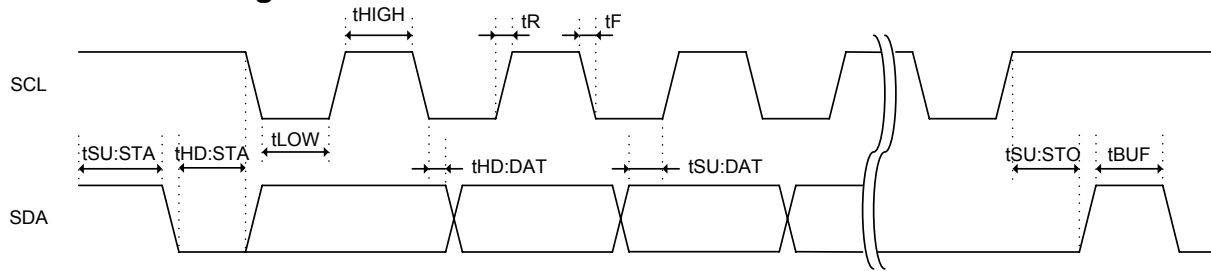

Figure1 I<sup>2</sup>C BUS Control Signal timing chart

I<sup>2</sup>C BUS register

1) The explanation of I<sup>2</sup>C Bus

I<sup>2</sup>C Bus (Inter IC Bus) is the bus system which the PHILIPS company developed.

It does controls such as the start, the stop by two control signals of SDA (Serial Data) and SCL (Serial Clock).

The output of each signal is open drain and forms out of wired OR.

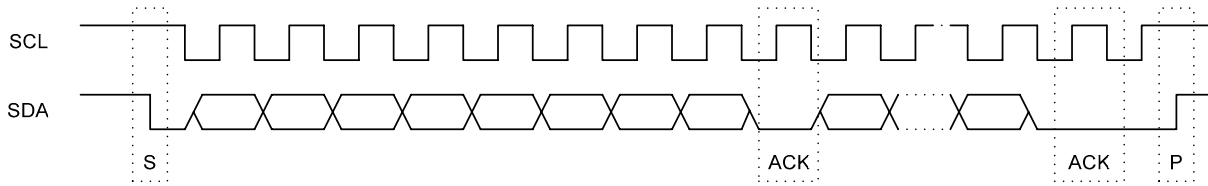

S: Start condition

P: Stop condition

ACK: Acknowledge

Data is transmitted in the MSB first. 1 unit is composed of 8 bits and ACK is put back from the slave to confirm. Slave IC reads data with rising edge of SCL. Master IC changes data by falling edge in SCL.

2) The control register

Table1 Slave Address

MSB							LSB
1	1	1	0	1	1	1	0

Note; LV1117N/NV are reception exclusive use. It depends and it uses LSB by the "0" fixation.

Table2 I<sup>2</sup>C Bus transmission

Function	Sub Address		Data							
	BINARY	HEX	D7	D6	D5	D4	D3	D2	D1	D0
Input control/Gain control	0000 0001	01	0	0	Gain			Input		
Volume control	0000 0010	02	Channel			Volume				
Output/Surround/MODE control	0000 0011	03	L+R out gain			Surround		MODE		
Tone control [Bass]	0000 0100	04	0	0	0	Bass				
Tone control [TREBLE]	0000 0101	05	0	0	0	TREBLE				
Output port control	0000 0110	06	0	0	0	0	OUT3	OUT2	OUT1	OUT0

Table3 Input Selection

	Sub Address								Data							
	A7	A6	A5	A4	A3	A2	A1	A0	D7	D6	D5	D4	D3	D2	D1	D0
Mute	0	0	0	0	0	0	0	1	0	0	*	*	*	0	0	0
In A									0	0	*	*	*	0	0	1
In B									0	0	*	*	*	0	1	0
In C									0	0	*	*	*	0	1	1
In D									0	0	*	*	*	1	0	0

# LV1117N/1117NV

Table4 Gain control

	Sub Address								Data							
	A7	A6	A5	A4	A3	A2	A1	A0	D7	D6	D5	D4	D3	D2	D1	D0
-6dB	0	0	0	0	0	0	0	1	0	0	0	1	1	*	*	*
-4dB									0	0	0	1	0	*	*	*
0dB									0	0	0	0	0	*	*	*
+4dB									0	0	1	1	0	*	*	*
+6dB									0	0	1	1	1	*	*	*

Table5 Mode control

	Sub Address								Data							
	A7	A6	A5	A4	A3	A2	A1	A0	D7	D6	D5	D4	D3	D2	D1	D0
Total	0	0	0	0	0	0	1	1	*	*	*	*	*	*	0	0
Matrix									*	*	*	*	*	*	0	1
Mono									*	*	*	*	*	*	1	0
Pseudo									*	*	*	*	*	*	1	1

Table6 Surround control

	Sub Address								Data							
	A7	A6	A5	A4	A3	A2	A1	A0	D7	D6	D5	D4	D3	D2	D1	D0
OFF	0	0	0	0	0	0	1	1	*	*	*	0	0	0	*	*
MODE-C									*	*	*	0	1	1	*	*
MODE-B									*	*	*	0	1	0	*	*
MODE-A									*	*	*	0	0	1	*	*
MODE-F												1	1	1		
MODE-E												1	1	0		
MODE-D									*	*	*	1	0	1	*	*

Note; At the time of forced mono mode, there is not surround effect.

Note; Output gain = Step1 < Step7

Table7 L+R Output Gain control

	Sub Address								Data							
	A7	A6	A5	A4	A3	A2	A1	A0	D7	D6	D5	D4	D3	D2	D1	D0
MUTE	0	0	0	0	0	0	1	1	0	0	0	*	*	*	*	*
Step1									0	0	1	*	*	*	*	*
Step2									0	1	0	*	*	*	*	*
Step3									0	1	1	*	*	*	*	*
Step4									1	0	0	*	*	*	*	*
Step5									1	0	1	*	*	*	*	*
Step6									1	1	0	*	*	*	*	*
Step7									1	1	1	*	*	*	*	*

Note; Output gain = Step1 < Step7



# LV1117N/1117NV

Table8 Tone control [Bass control]

	Sub Address								Data														
	A7	A6	A5	A4	A3	A2	A1	A0	D7	D6	D5	D4	D3	D2	D1	D0							
+20dB	0	0	0	0	0	1	0	0	0	0	0	0	1	0	1	0							
+18dB									0	0	0	0	1	0	0	1							
+16dB									0	0	0	0	1	0	0	0	0						
+14dB									0	0	0	0	0	1	1	1	1						
+12dB									0	0	0	0	0	1	1	0	0						
+10dB									0	0	0	0	0	1	0	1	1						
+8dB									0	0	0	0	0	1	0	0	0						
+6dB									0	0	0	0	0	1	1	1	1						
+4dB									0	0	0	0	0	1	0	0	1	0					
+2dB									0	0	0	0	0	1	0	0	1	0					
0dB									0	0	0	0	0	1	0	0	0	0	0	0	0	0	0
-2dB									0	0	0	0	0	1	0	0	0	1	0	0	0	1	0
-4dB									0	0	0	0	0	1	0	0	1	0	0	1	0	0	0
-6dB									0	0	0	0	0	1	0	0	1	0	0	1	1	1	0
-8dB									0	0	0	0	0	1	0	1	0	1	0	0	0	0	0
-10dB									0	0	0	0	0	1	0	1	0	1	0	1	0	1	0
-12dB									0	0	0	0	0	1	0	1	1	1	1	1	0	0	0
-14dB									0	0	0	0	0	1	0	1	1	1	1	1	1	1	0
-16dB									0	0	0	0	0	1	1	0	0	0	0	0	0	0	0
-18dB									0	0	0	0	0	1	1	0	0	1	1	0	0	1	0
-20dB	0	0	0	0	0	1	1	0	1	1	0	1	0	0	0								

Table9 Tone control [TREBLE control]

	Sub Address								Data														
	A7	A6	A5	A4	A3	A2	A1	A0	D7	D6	D5	D4	D3	D2	D1	D0							
+18dB	0	0	0	0	0	1	0	1	0	0	0	0	1	0	0	1							
+16dB									0	0	0	0	1	0	0	0							
+14dB									0	0	0	0	0	1	1	1	1						
+12dB									0	0	0	0	0	1	1	0	0						
+10dB									0	0	0	0	0	1	0	1	1						
+8dB									0	0	0	0	0	1	0	0	0						
+6dB									0	0	0	0	0	1	1	1	1						
+4dB									0	0	0	0	0	1	0	0	1	0					
+2dB									0	0	0	0	0	1	0	0	1	0					
0dB									0	0	0	0	0	1	0	1	0	0	0	0	0	0	0
-2dB									0	0	0	0	0	1	0	0	0	1	0	0	0	1	0
-4dB									0	0	0	0	0	1	0	0	1	0	0	1	0	0	0
-6dB									0	0	0	0	0	1	0	0	1	0	0	1	1	1	0
-8dB									0	0	0	0	0	1	0	1	0	1	0	0	0	0	0
-10dB									0	0	0	0	0	1	0	1	0	1	0	1	0	1	0
-12dB									0	0	0	0	0	1	0	1	1	1	1	1	0	0	0
-14dB									0	0	0	0	0	1	0	1	1	1	1	1	1	1	0
-16dB									0	0	0	0	0	1	1	0	0	0	0	0	0	0	0
-18dB									0	0	0	0	0	1	1	0	0	1	1	0	0	1	0

# LV1117N/1117NV

Table10 Volume control

	Sub Address								Data							
	A7	A6	A5	A4	A3	A2	A1	A0	D7	D6	D5	D4	D3	D2	D1	D0
0dB									*	*	0	0	0	0	0	0
-1dB									*	*	0	0	0	0	0	1
-2dB									*	*	0	0	0	0	1	0
-3dB									*	*	0	0	0	0	1	1
-4dB									*	*	0	0	0	1	0	0
-5dB									*	*	0	0	0	1	0	1
-6dB									*	*	0	0	0	1	1	0
-7dB									*	*	0	0	0	1	1	1
-8dB									*	*	0	0	1	0	0	0
-9dB									*	*	0	0	1	0	0	1
-10dB									*	*	0	0	1	0	1	0
-11dB									*	*	0	0	1	0	1	1
-12dB									*	*	0	0	1	1	0	0
-13dB									*	*	0	0	1	1	0	1
-14dB									*	*	0	0	1	1	1	0
-16dB									*	*	0	0	1	1	1	1
-18dB									*	*	0	1	0	0	0	0
-20dB									*	*	0	1	0	0	0	1
-22dB									*	*	0	1	0	0	1	0
-24dB									*	*	0	1	0	0	1	1
-26dB									*	*	0	1	0	1	0	0
-28dB									*	*	0	1	0	1	0	1
-30dB									*	*	0	1	0	1	1	0
-32dB									*	*	0	1	0	1	1	1
-34dB	0	0	0	0	0	0	1	0	*	*	0	1	1	0	0	0
-36dB									*	*	0	1	1	0	0	1
-38dB									*	*	0	1	1	0	1	0
-40dB									*	*	0	1	1	0	1	1
-42dB									*	*	0	1	1	1	0	0
-44dB									*	*	0	1	1	1	0	1
-46dB									*	*	0	1	1	1	1	0
-48dB									*	*	0	1	1	1	1	1
-50dB									*	*	1	0	0	0	0	0
-52dB									*	*	1	0	0	0	0	1
-54dB									*	*	1	0	0	0	1	0
-56dB									*	*	1	0	0	0	1	1
-58dB									*	*	1	0	0	1	0	0
-60dB									*	*	1	0	0	1	0	1
-62dB									*	*	1	0	0	1	1	0
-64dB									*	*	1	0	0	1	1	1
-66dB									*	*	1	0	1	0	0	0
-68dB									*	*	1	0	1	0	0	1
-70dB									*	*	1	0	1	0	1	0
-72dB									*	*	1	0	1	0	1	1
-74dB									*	*	1	0	1	1	0	0
-76dB									*	*	1	0	1	1	0	1
-78dB									*	*	1	0	1	1	1	0
-80dB									*	*	1	0	1	1	1	1
-∞dB									*	*	1	1	0	0	0	0

# LV1117N/1117NV

**Table11 Volume channel control**

	Sub Address								Data							
	A7	A6	A5	A4	A3	A2	A1	A0	D7	D6	D5	D4	D3	D2	D1	D0
L-ch									0	1	*	*	*	*	*	*
R-ch	0	0	0	0	0	0	1	0	1	0	*	*	*	*	*	*
L/R									1	1	*	*	*	*	*	*

**Table12 Output port control**

	Sub Address								Data							
	A7	A6	A5	A4	A3	A2	A1	A0	D7	D6	D5	D4	D3	D2	D1	D0
On (sink)									0	0	0	0	0	0	0	0
Off (open)	0	0	0	0	0	1	1	0	0	0	0	0	1	1	1	1

## Pin Functions [LV1117N]

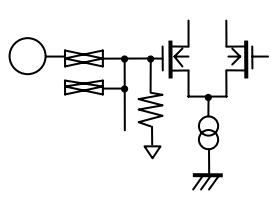
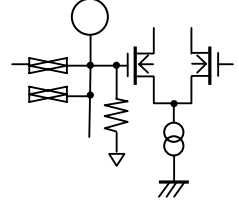
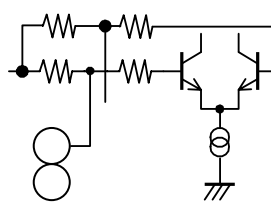
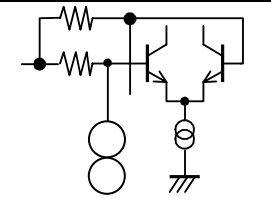
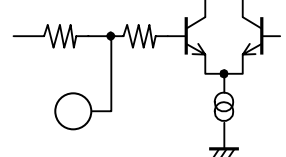
Pin No	Function	Voltage	Remarks	Internal equivalent circuit
1	GND	0		
2	INPUT-A(R)	VREF	Input Impedance $r_i=50k\Omega$	
41	INPUT-A(L)			
3	INPUT-B(R)			
40	INPUT-B(L)			
4	INPUT-C(R)			
39	INPUT-C(L)			
5	INPUT-D(R)			
38	INPUT-D(L)			
6	LINE-OUT(R)	VREF	Function SW Output $r_o=700\Omega$	
37	LINE-OUT(L)			
7	DC Cut(R)	VREF	DC offset cancellation capacitor connection pin	
36	DC Cut(L)			
8	ST-1	VREF	Pseudo stereo phase shift capacitor connection pin	
35	ST-2			
9	AVISS LPF	VREF	Capacitor connection pin for surround low pass filter	

Continued on next page.

# LV1117N/1117NV

Continued from preceding page.

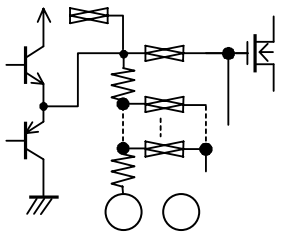
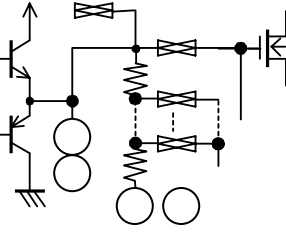
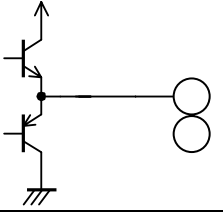
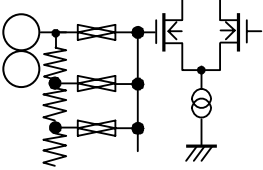
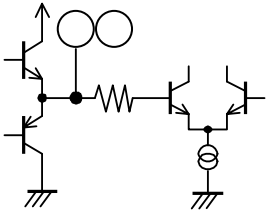
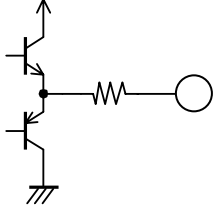
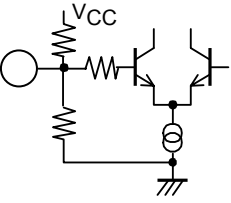
Pin No	Function	Voltage	Remarks	Internal equivalent circuit
10	TREBLE(R)	VREF	Capacitor connection pin for configuring treble filter	
33	TREBLE(L)			
11	BASS-1(R)	VREF	Bass band filter configuration capacitor and resistor connection pins	
32	BASS-1(L)			
12	BASS-2(R)			
31	BASS-2(L)			
13	OUT(R)	VREF	Output Impedance $r_o=100\Omega$	
30	OUT(L)			
14	EVR-IN(R)	VREF	Input Impedance $r_i=50k\Omega$	
29	EVR-IN(L)			
15	EVR-OUT(R)	VREF	Output Impedance $r_o=100\Omega$	
28	EVR-OUT(L)			
16	L+R OUT	VREF	Output Impedance $r_o=10k\Omega$	
17	VREF	$0.5V_{CC}$	Reference voltage	

Continued on next page.

# LV1117N/1117NV

Continued from preceding page.

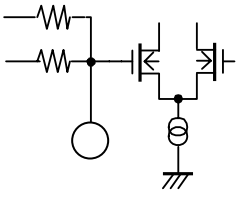
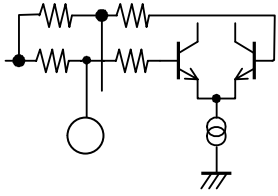
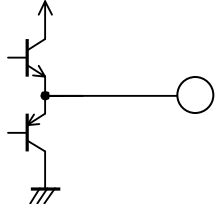
Pin No	Function	Voltage	Remarks	Internal equivalent circuit
18	V <sub>CC</sub>	V <sub>CC</sub>		
19	V <sub>DD</sub>	V <sub>DD</sub>		
20	Output 2		Nch open drain port output	
21	Output 3			
22	Output 1			
23	Output 0			
24	I <sup>2</sup> C-DATA		I <sup>2</sup> C control data input	
25	I <sup>2</sup> C-CLK			
26	V <sub>SS</sub>	0		
27	L+R LPF	VREF	Internal resistor	
34	AViSS HPF	VREF		
42	ANALOG GND	VREF		

# LV1117N/1117NV

## Treble / Bass Band Block Equivalent Circuit Diagram

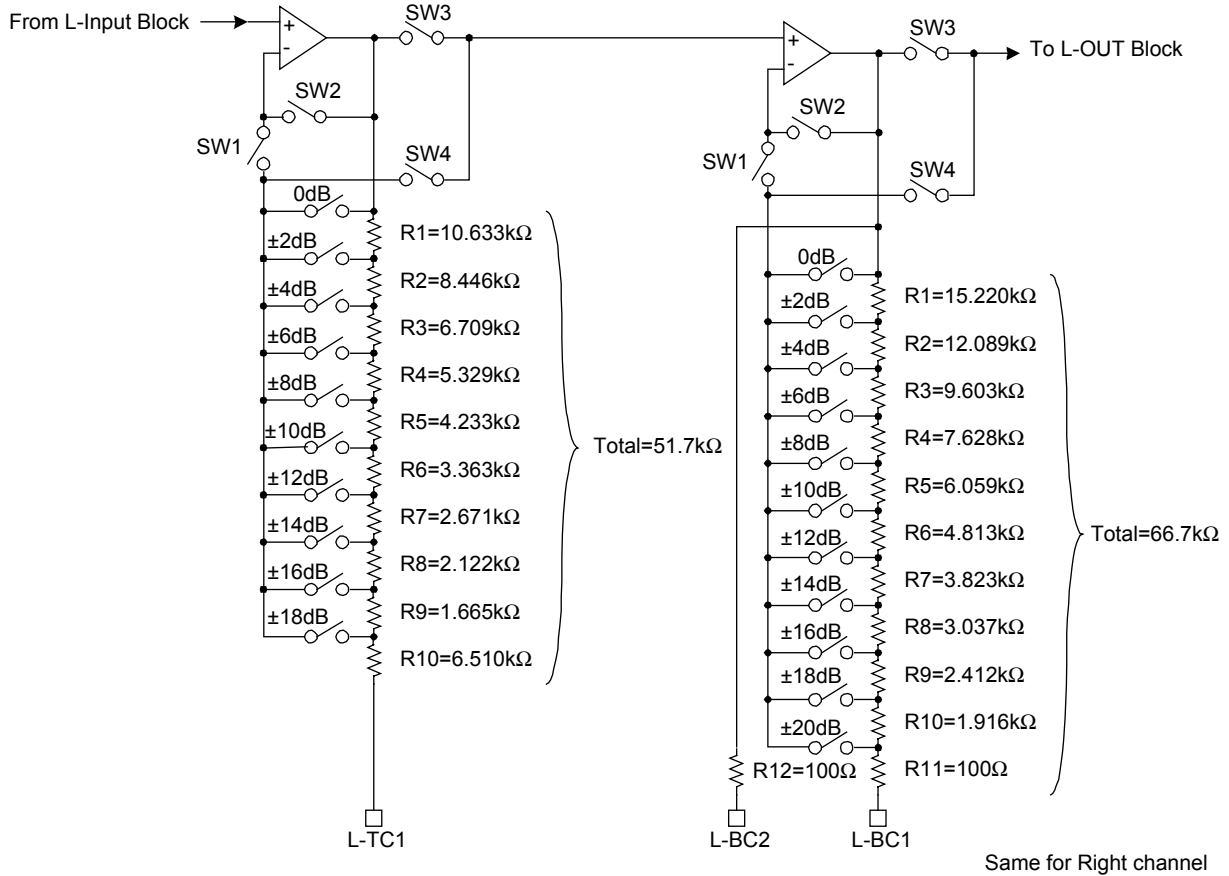

During boost, SW1 and SW3 are ON, during cut, SW2 and SW4 are ON, when 0dB, 0dBSW and SW2 and SW3 are ON.

## L+R Block Equivalent Circuit Diagram

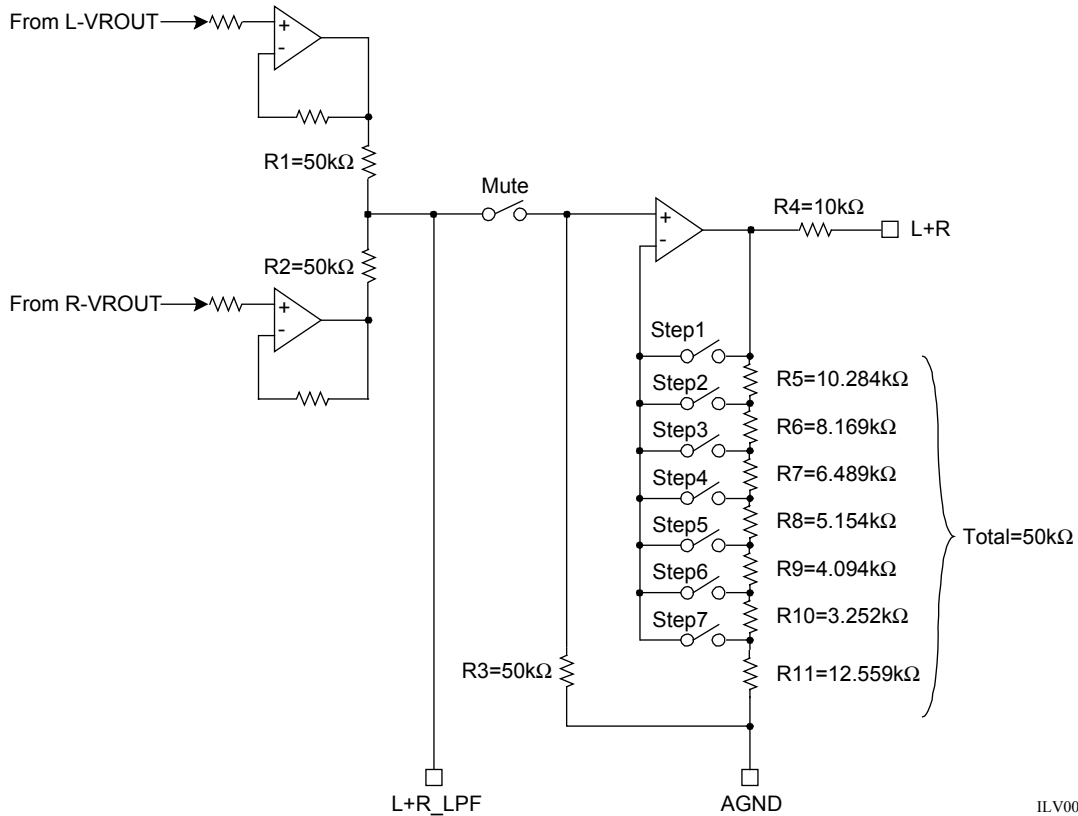

ILV00257

**Tone Circuit Constant Calculation Examples**

Treble Band Circuit: The shelving characteristics can be obtained for the treble band. The equivalent circuit and calculation formula during boost are indicated below.

• Calculation example 1

Specification Set frequency:  $f = 10000\text{Hz}$   
 Gain during maximum boost:  $G_{+18\text{dB}} = 17.5\text{dB}$   
 Let us use  $R1 = 6.51\text{k}\Omega$  and  $R2 = 45.19\text{k}\Omega$   
 The above constants are inserted in the following formula

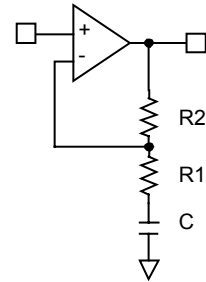

$$G = 20 \times \text{Log}_{10} \left[ 1 + \frac{R2}{\sqrt{R1^2 + (1/\omega C)^2}} \right]$$

$$C = \frac{1}{2\pi f \sqrt{\left[ \frac{R2}{10^{G/20} - 1} \right]^2 - R1^2}}$$

$$= \frac{1}{2\pi \times 24000 \sqrt{\left[ \frac{45190}{7.50 - 1} \right]^2 - 6510^2}} \approx 2700 \text{ (pF)}$$

Bass Band Circuit: The equivalent circuit and the formula for calculating the external RC with a mean frequency of 100Hz are shown below.

• Base band equivalent circuit diagram

• Calculation example 1

specification Mean frequency:  $f0 = 100\text{Hz}$   
 Gain during maximum boost:  $G_{+20\text{dB}} = 20\text{dB}$   
 Let us use  $R1 = 0\text{k}\Omega$  and  $R2 = 66.7\text{k}\Omega$ , and  $C1 = C2 = C$ .

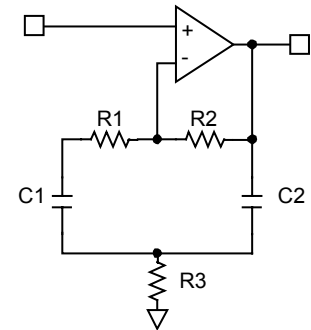

We obtain R2 from  $G = 20\text{dB}$

$$G = 20 \times \text{Log}_{10} \left[ 1 + \frac{R2}{2R3} \right]$$

$$R3 = \frac{R2}{2 (10^{G+20\text{dB}/20} - 1)} = \frac{66700}{2 (10 - 1)} \approx 3.6\text{k}\Omega$$

We obtain C from mean frequency  $f0 = 100\text{Hz}$

$$f0 = \frac{1}{2\pi \sqrt{(R3R2C1C2)}}$$

$$C = \frac{1}{2\pi f0 \sqrt{R3R2}} = \frac{1}{2\pi \times 100 \sqrt{66700 \times 3600}} \approx 0.1\mu\text{F}$$

We obtain Q

$$Q = \frac{R3R2}{2R3} \times \frac{1}{\sqrt{R3R2}} \approx 2.15$$

Note item when using

- (1) When turning on the power, the setting inside is unsettled.  
 Before setting control data, it does a mute.
- (2) To prevent the digital noise of the high frequency influence a terminal. (SCL, SDA)  
 It can be protected by a signal line in the ground pattern or by the shielding cable.
- (3) To prevent the noise in changing a mode, please set the mute ON.

# LV1117N/1117NV

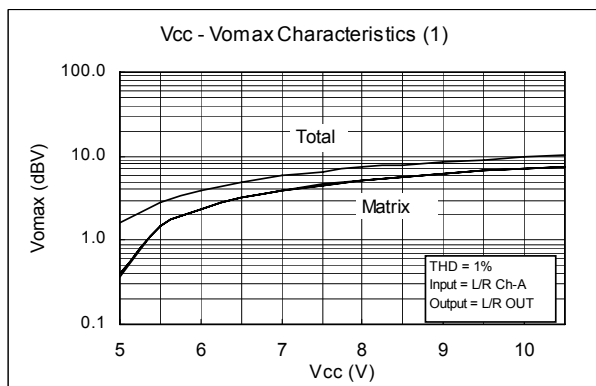
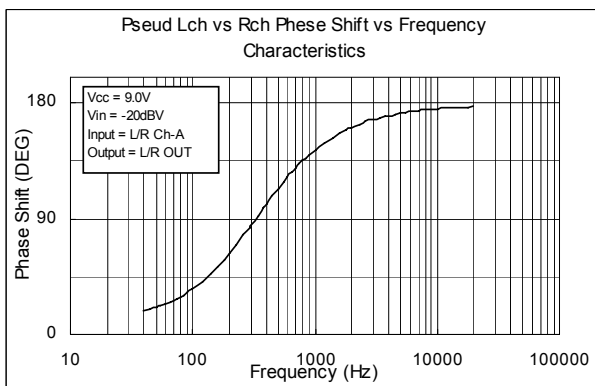
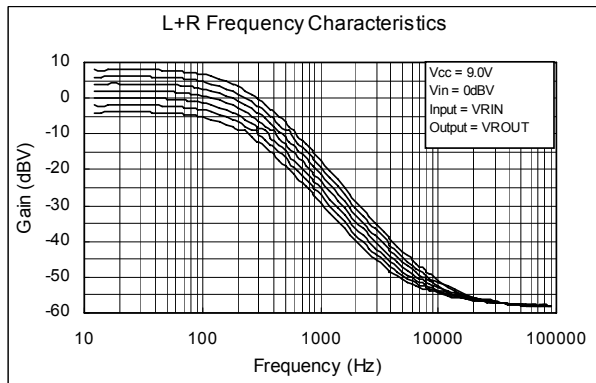
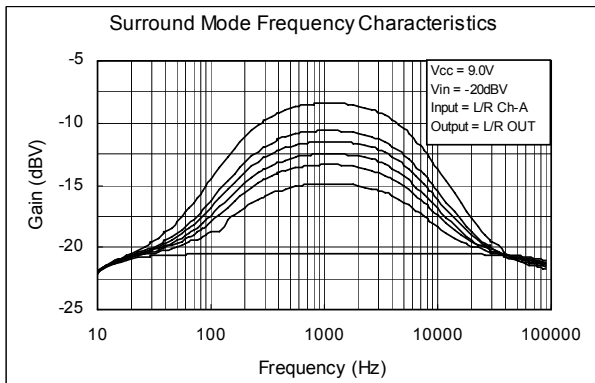
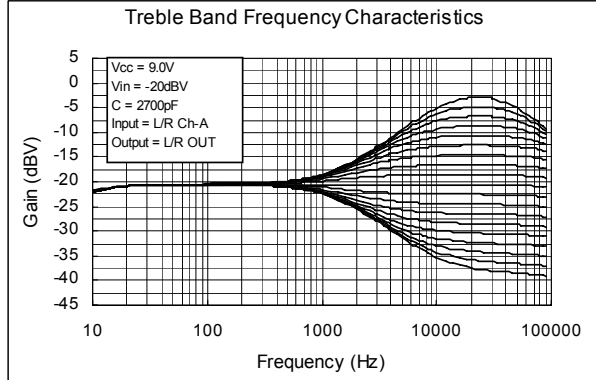
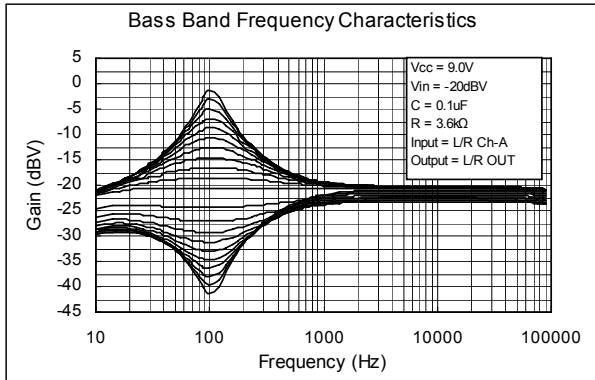
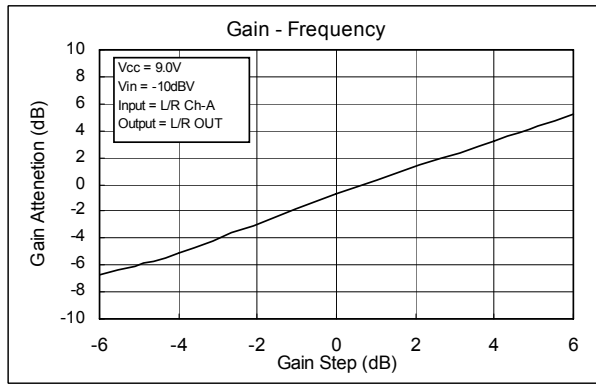
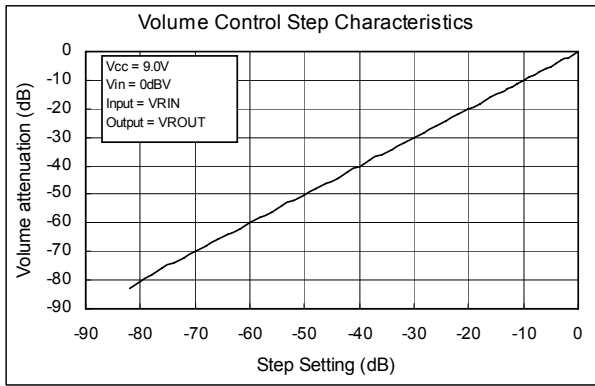



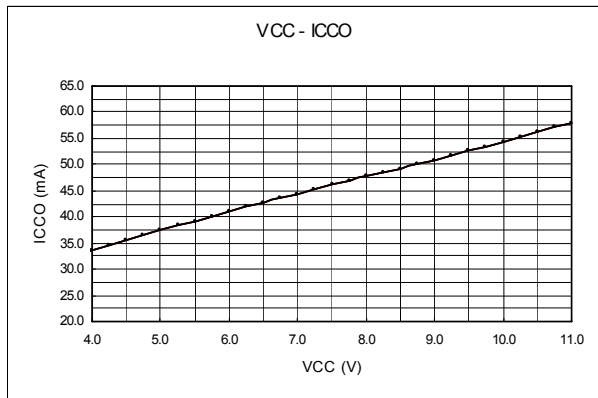
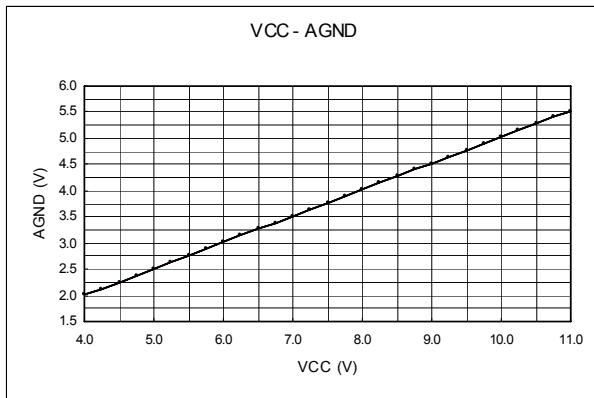
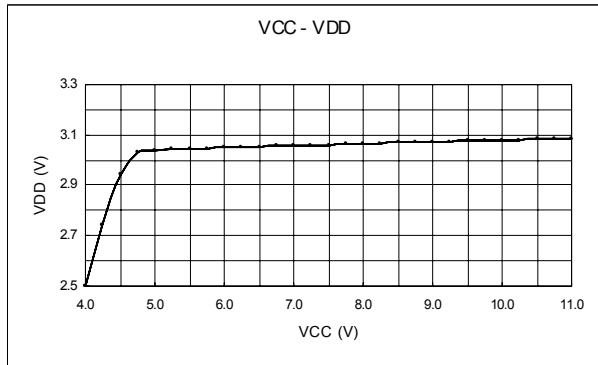
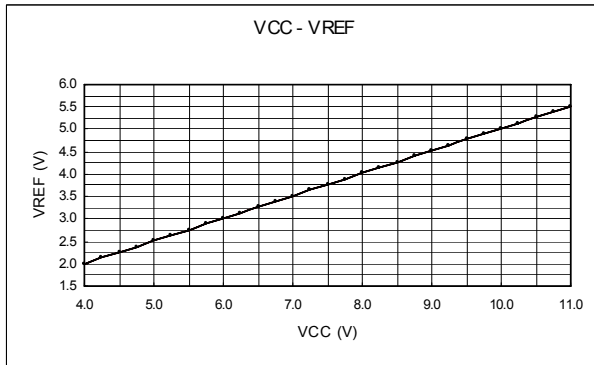
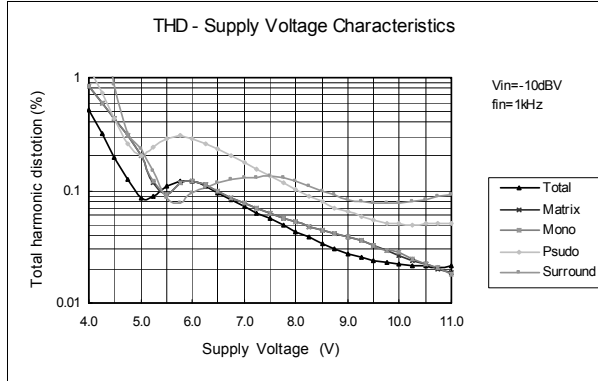
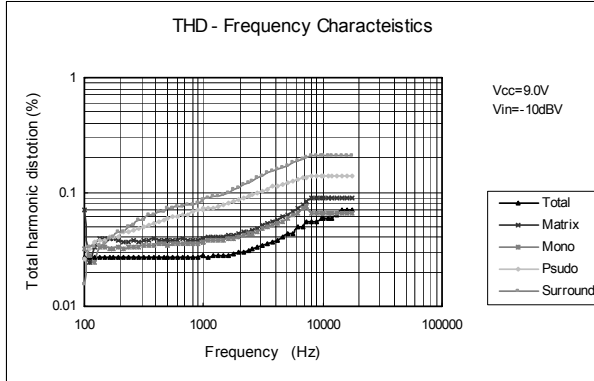
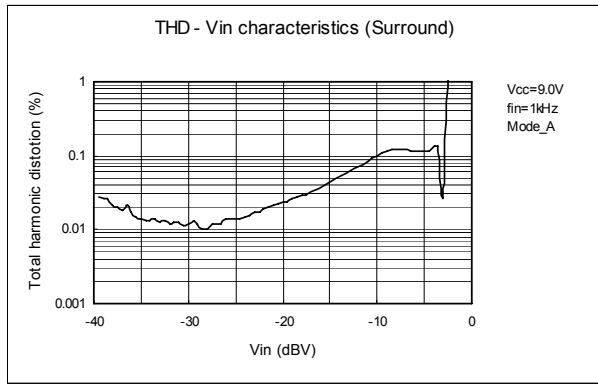
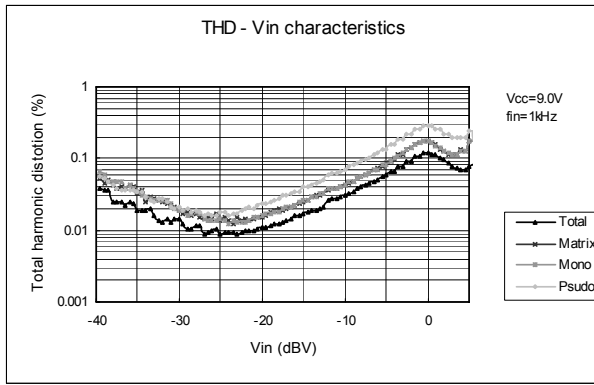

- SANYO Semiconductor Co.,Ltd. assumes no responsibility for equipment failures that result from using products at values that exceed, even momentarily, rated values (such as maximum ratings, operating condition ranges, or other parameters) listed in products specifications of any and all SANYO Semiconductor Co.,Ltd. products described or contained herein.
- SANYO Semiconductor Co.,Ltd. strives to supply high-quality high-reliability products, however, any and all semiconductor products fail or malfunction with some probability. It is possible that these probabilistic failures or malfunction could give rise to accidents or events that could endanger human lives, trouble that could give rise to smoke or fire, or accidents that could cause damage to other property. When designing equipment, adopt safety measures so that these kinds of accidents or events cannot occur. Such measures include but are not limited to protective circuits and error prevention circuits for safe design, redundant design, and structural design.
- In the event that any or all SANYO Semiconductor Co.,Ltd. products described or contained herein are controlled under any of applicable local export control laws and regulations, such products may require the export license from the authorities concerned in accordance with the above law.
- No part of this publication may be reproduced or transmitted in any form or by any means, electronic or mechanical, including photocopying and recording, or any information storage or retrieval system, or otherwise, without the prior written consent of SANYO Semiconductor Co.,Ltd.
- Any and all information described or contained herein are subject to change without notice due to product/technology improvement, etc. When designing equipment, refer to the "Delivery Specification" for the SANYO Semiconductor Co.,Ltd. product that you intend to use.
- Information (including circuit diagrams and circuit parameters) herein is for example only; it is not guaranteed for volume production.
- Upon using the technical information or products described herein, neither warranty nor license shall be granted with regard to intellectual property rights or any other rights of SANYO Semiconductor Co.,Ltd. or any third party. SANYO Semiconductor Co.,Ltd. shall not be liable for any claim or suits with regard to a third party's intellectual property rights which has resulted from the use of the technical information and products mentioned above.

This catalog provides information as of February, 2008. Specifications and information herein are subject to change without notice.