

# LOW PROFILE LEADED CERAMIC RESONATOR

HWZT-RS

\*C = Pb in ceramic (exempt per RoHS 2002/95/EC Annex (7)) \***C/RoHS**  
Compliant



## FEATURES:

- Low resonant impedance.
- Small size, Light weight.
- Low cost timing solution.

## APPLICATIONS:

- Clock oscillation for microcontrollers
- Telephones
- Household electric appliances

## STANDARD SPECIFICATIONS:

Item	Requirement
Frequency Range	4.00MHz to 8.00MHz
Resonant Impedance	30 ( $\Omega$ ) max
Frequency Tolerance	$\pm 0.5\%$
Frequency Stability	$\pm 0.3\%$ max. (-25°C to +85°C)
Withstanding Voltage	50V (DC , 1 min)
Rating Voltage	
(1) D.C.Voltage	6 V.D.C. max
(2) A.C. Voltage	15 Vp-p. max
Load Capacitance	30pF $\pm 20\%$ (C1=C2)
Insulation Resistance	500M $\Omega$ min. (DC 10V)
Operation Temperature	-25°C to +85°C
Storage Temperature	-40°C to +85°C
Aging Rate (Fosc)	$\pm 0.3\%$ max. (From initial value)

## TEST CONDITION AND TEST CIRCUIT:

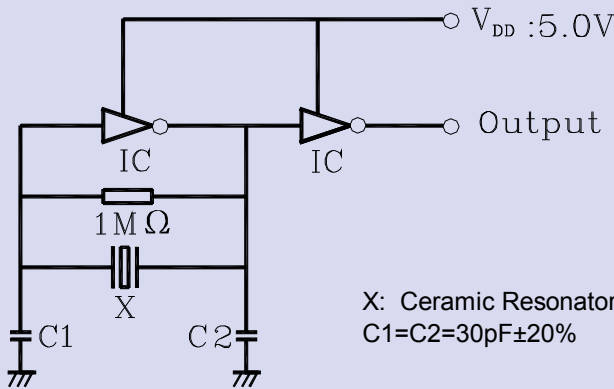

Parts shall be measured under a condition (Temp.: 20 $\pm$ 15°C, Humidity: 65 $\pm$ 20% R.H.) unless the standard condition (Temp: 25 $\pm$ 2°C, Humidity: 65 $\pm$ 5% R.H.) is regulated to measure

## OPTIONS & PART IDENTIFICATION:

HWZT - Frequency- RS - □

**Frequency**  
X.XXMHz

**Packaging**  
Blank for Bulk pack  
A for AMMO pack\*

\* AMMO pack lead length 13.5mm

# LOW PROFILE LEADED CERAMIC RESONATOR

HWZT-RS

\*C = Pb in ceramic (exempt per RoHS 2002/95/EC Annex (7)) \***C/RoHS**  
Compliant



## OUTLINE DRAWING:

### Bulk Pack

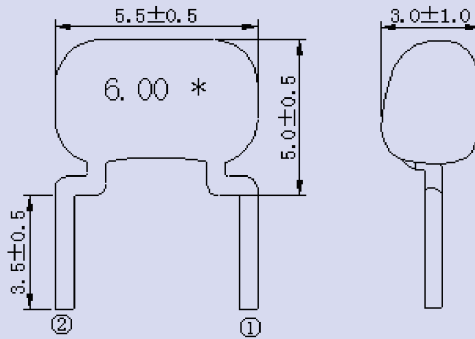

### AMMO Pack

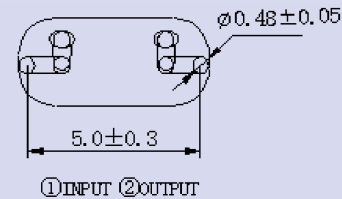
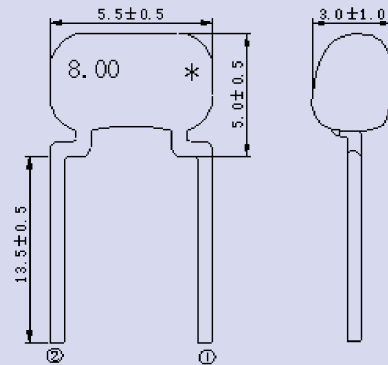

Dimension: mm

## CAUTION

- Do not apply excess mechanical stress to the component body or terminations. Do not attempt to re-form or bend the components as this will cause damage to the component.
- This component is not hermetically sealed. Do not clean or wash the component.
- Reflow Soldering: Do not use strong acidity flux, such as flux with chlorine content of greater than 0.2wt% during Reflow Soldering.
- Do not expose the component to open flame.
- This specification applies to the functionality of the component as a single unit. The customer is advised to insure that the component is thoroughly evaluated in the application circuit.
- Shelf Life: The warranted Shelf Life of this product is Six Months after the Delivery Date under the conditions of sealed, unopened, original packaging.
- Storage Conditions: If the product is to be stored for a period greater than Six Months after the Delivery Date, it is recommended that the customer confirm the solderability and characteristics for the product prior to use.
- This product is not recommended for use in industrial related Automotive, Medical, Safety, Military, or other high-reliability life dependant applications. Contact Abracon Corporation prior to using this product when in doubt.