

Automotive dual-line Transil™, transient voltage suppressor (TVS) for CAN bus

Datasheet – production data

Features

- Dual line ESD and EOS protection
- Bidirectional device
- Max pulse power: 230 W (8/20 μs)
- Stand-off voltage 24 V
- Low clamping factor V_{CL}/V_{BR}
- Fast response time
- Low leakage current
- Small plastic package

Benefits

- ESD and EOS protection for CAN transceiver
- SOT23 package for space saving on high density printed circuit board
- Transil diodes providing high overvoltage protection by clamping action and instantaneous response to transient overvoltages

Complies with the following standards

- ISO10605 - C = 150 pF, R = 330 Ω:
 - 30 kV (air discharge)
 - 30 kV (contact discharge)
- ISO10605 - C = 330 pF, R = 330 Ω:
 - 30 kV (air discharge)
 - 30 kV (contact discharge)
- ISO7637-2:
 - Pulse 3a: $V_s = -150$ V
 - Pulse 3b: $V_s = +100$ V

Application

Automotive controller area network (CAN) bus lines where electrostatic discharge and other transients must be suppressed.

TM: Transil is a trademark of STMicroelectronics

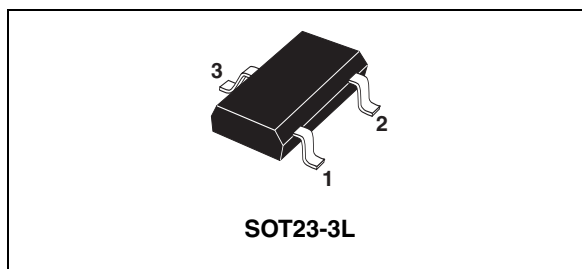
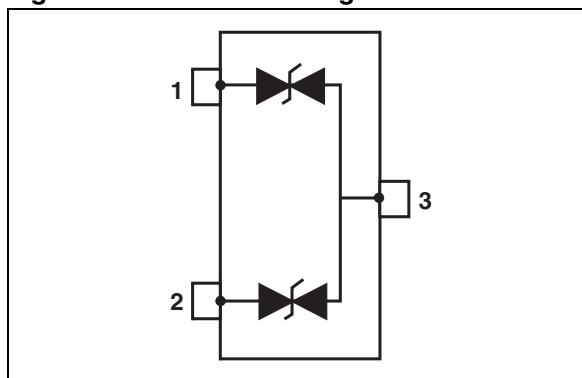

Figure 1. Functional diagram



Description

The ESDCAN24-2BLY is a dual-line Transil specifically designed for the protection of the automotive CAN bus lines against electrostatic discharge (ESD).

1 Characteristics

Table 1. Absolute maximum ratings (T_{amb} = 25°C)

Symbol	Parameter		Value	Unit
V _{PP}	Electrostatic discharge capability	ISO10605 - C = 150 pF, R = 330 Ω: Contact discharge	30	kV
		Air discharge	30	
		ISO10605 - C = 330 pF, R = 330 Ω: Contact discharge	30	
		Air discharge	30	
		HBM MIL STD 883	8	
P _{PP}	Peak pulse power dissipation 8/20 μs ⁽¹⁾	T _j initial = T _{amb}	230	W
I _{PP}	Peak pulse current typical value (8/20 μs)		5.5	A
T _j	Maximum junction temperature		150	°C
T _{op}	Operating junction temperature range		-40 to +125	°C
T _{stg}	Storage temperature range		-55 to +150	°C

1. For a surge greater than the maximum values, the diode will fail in short-circuit.

Figure 2. Electrical characteristics (definitions)

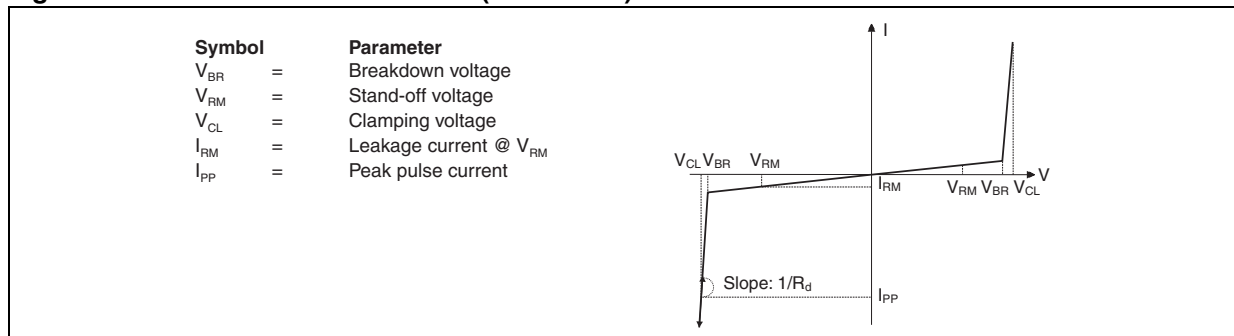

Table 2. Electrical characteristics (values, T_{amb} = 25 °C)

Symbol	Test conditions	Min.	Typ.	Max.	Unit
V _{RM}	Stand-off voltage			24	V
V _{BR}	I _R = 1 mA	27		32	V
I _{RM}	V _{RM} = 24 V			100	nA
V _{CL}	Pulse ISO7637-2 Pulse 3b			40	V
V _{CL}	Pulse ISO7637-2 Pulse 3a	-40			V
V _{CL}	I _{PP} = 5 A, 8/20μs			43	V
αT ⁽¹⁾	Voltage temperature coefficient			9	10 ⁻⁴ /°C
C	V _R = 0 V DC, F = 1 MHz			30	pF

1. ΔV_{BR} = αT x (T_{amb} -25) x V_{BR}(25 °C)

Figure 3. Response to ISO 7637-2 Pulse 3a on each channel

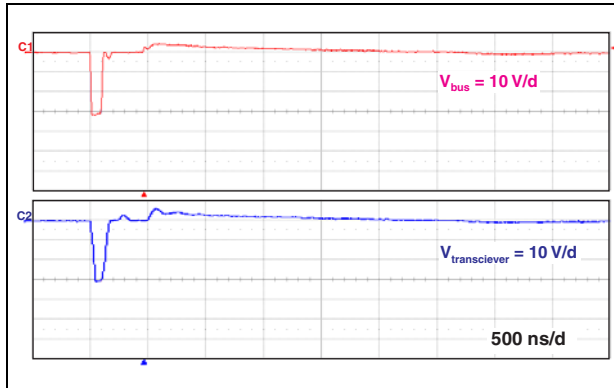

Figure 4. Response to ISO 7637-2 Pulse 3b on each channel

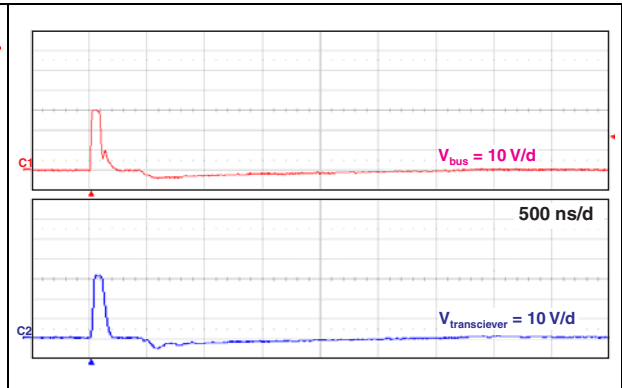

Figure 5. ESD response to ISO10605 - C = 150 pF, R = 330 Ω (+25 kV air discharge) on each channel

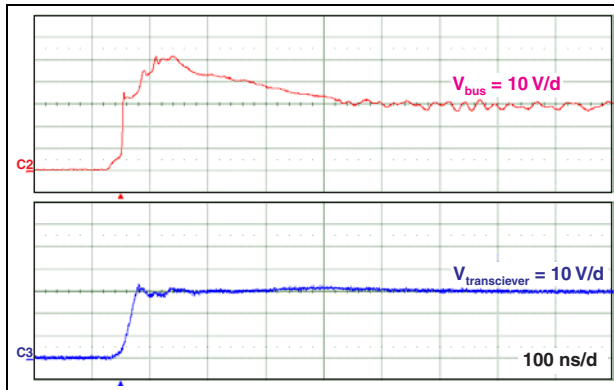

Figure 6. ESD response to ISO10605 - C = 150 pF, R = 330 Ω (-25 kV air discharge) on each channel

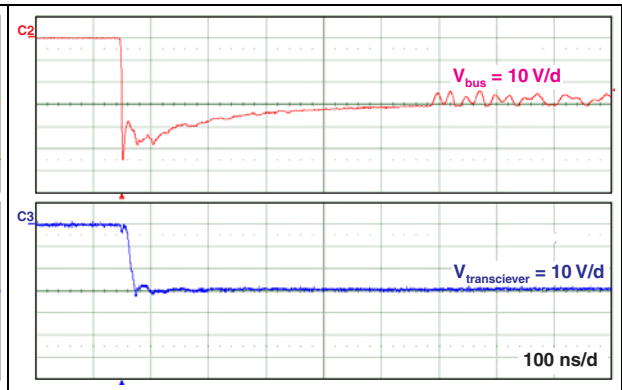

Figure 7. Peak pulse power dissipation versus initial junction temperature (maximum values)

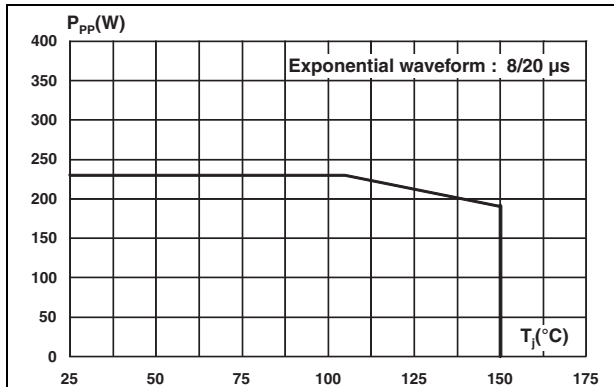

Figure 8. Peak pulse power dissipation versus pulse duration (maximum values)

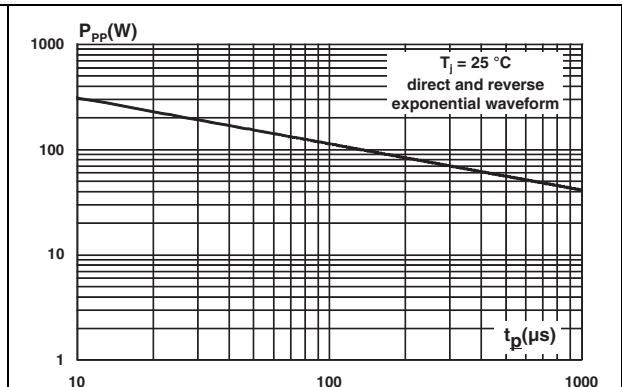

Figure 9. Clamping voltage versus peak pulse current (typical values, exponential waveform 8/20 μ s)

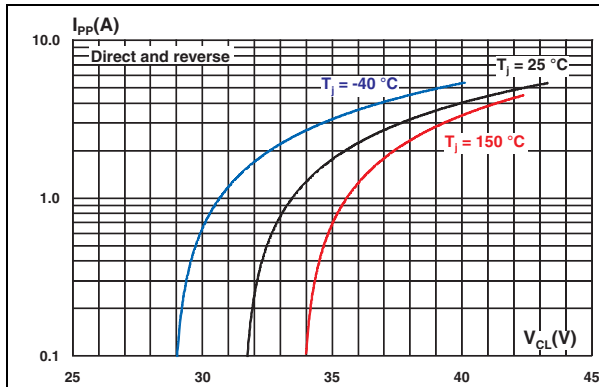

Figure 10. Junction capacitance versus reverse voltage applied (typical values)

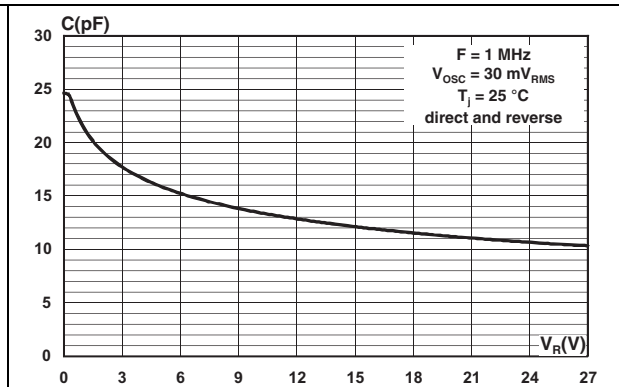

Figure 11. Leakage current versus junction temperature (typical values)

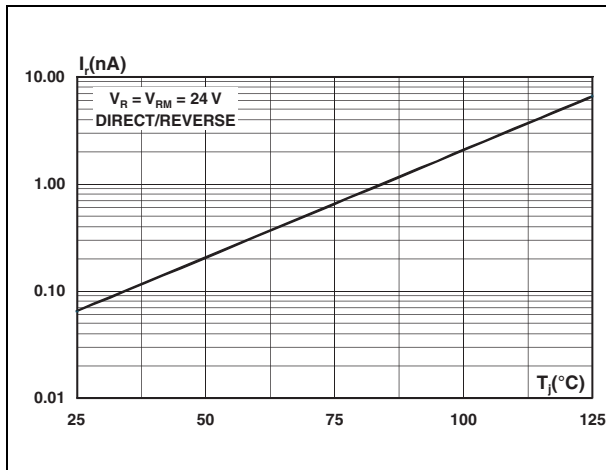
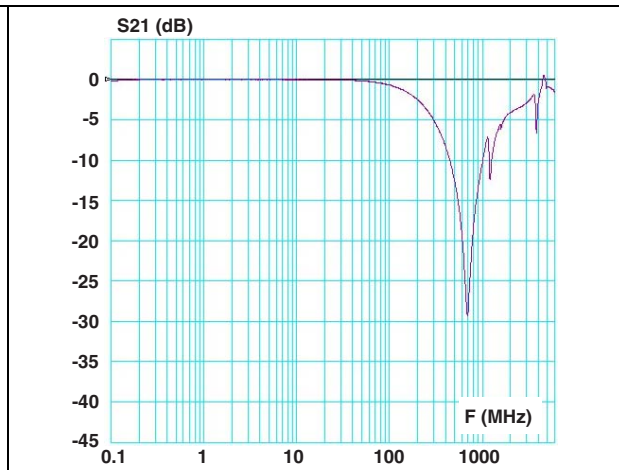

Figure 12. S21 attenuation measurement results of each channel



2 Application and design guidelines

More information is available in the ST Application note AN2689 "Protection of automotive electronics from electrical hazards, guidelines for design and component selection".

3 Ordering information scheme

Figure 13. Ordering information scheme

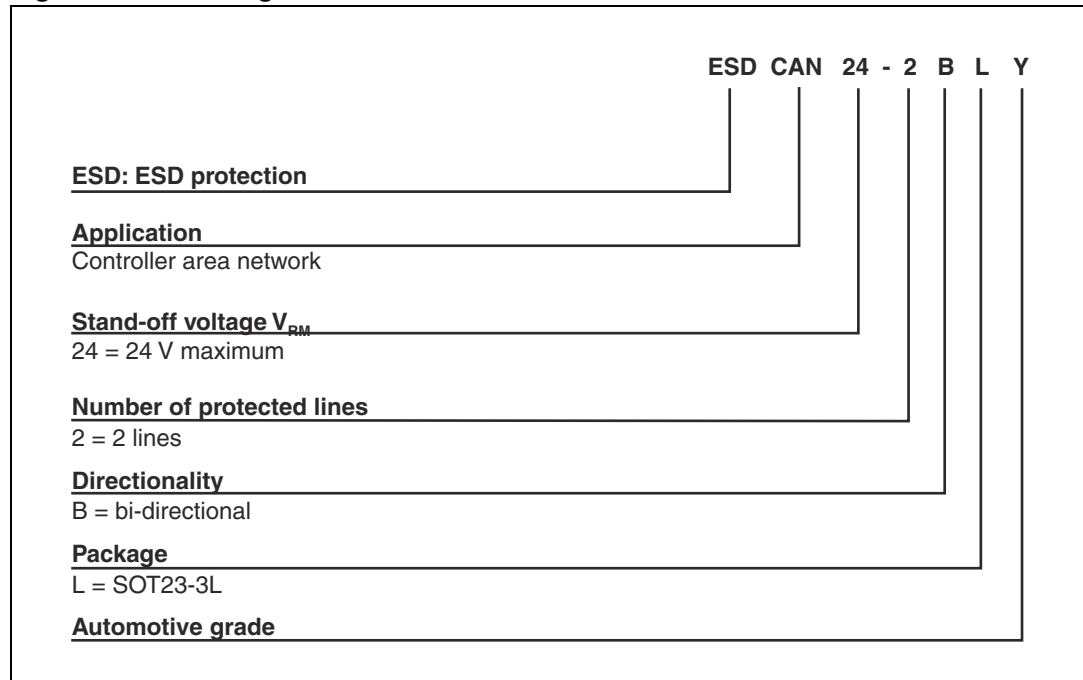

4 Package information

- Epoxy meets UL94, V0
- Lead-free packages

In order to meet environmental requirements, ST offers these devices in different grades of ECOPACK® packages, depending on their level of environmental compliance. ECOPACK® specifications, grade definitions and product status are available at: www.st.com. ECOPACK® is an ST trademark.

Table 3. SOT23-3L dimensions

Ref.	Dimensions			
	Millimeters		Inches	
	Min.	Max.	Min.	Max.
a	0°	8°	0°	8°
A	0.89	1.4	0.035	0.055
A1	0	0.1	0	0.004
B	0.3	0.51	0.012	0.02
c	0.085	0.18	0.003	0.007
D	2.75	3.04	0.108	0.12
e	0.85	1.05	0.033	0.041
e1	1.7	2.1	0.067	0.083
E	1.2	1.6	0.047	0.063
H	2.1	2.75	0.083	0.108
L	0.6 typ.		0.024 typ.	
L1	0.25	0.55	0.010	0.022
S	0.35	0.65	0.014	0.026

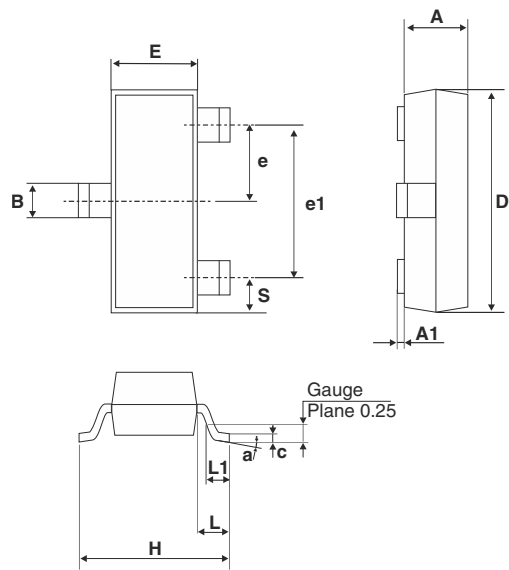
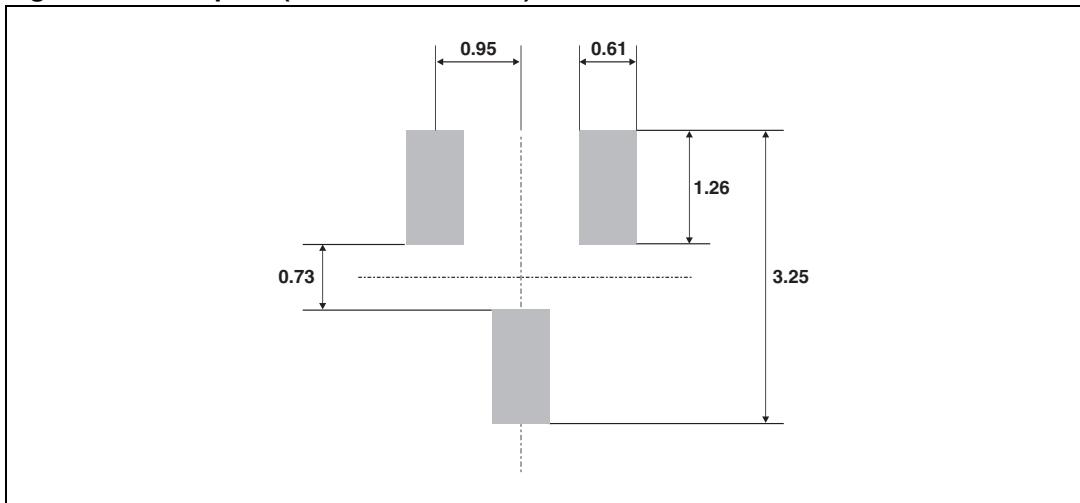

Figure 14. Footprint (dimensions in mm)



5 Ordering information

Table 4. Ordering information

Order code	Marking	Package	Weight	Base qty	Delivery mode
ESDCAN24-2BLY	EL24	SOT-23	9.795 mg	3000	Tape and reel

6 Revision history

Table 5. Document revision history

Date	Revision	Changes
29-May-2012	1	First issue.
04-Sep-2012	2	Update values for V_{RM} in Table 2 . Updated Figure 10 , Figure 11 , and Figure 13 .
07-Nov-2012	3	Added dimensions a and L1 in Table 3 .

Please Read Carefully:

Information in this document is provided solely in connection with ST products. STMicroelectronics NV and its subsidiaries ("ST") reserve the right to make changes, corrections, modifications or improvements, to this document, and the products and services described herein at any time, without notice.

All ST products are sold pursuant to ST's terms and conditions of sale.

Purchasers are solely responsible for the choice, selection and use of the ST products and services described herein, and ST assumes no liability whatsoever relating to the choice, selection or use of the ST products and services described herein.

No license, express or implied, by estoppel or otherwise, to any intellectual property rights is granted under this document. If any part of this document refers to any third party products or services it shall not be deemed a license grant by ST for the use of such third party products or services, or any intellectual property contained therein or considered as a warranty covering the use in any manner whatsoever of such third party products or services or any intellectual property contained therein.

UNLESS OTHERWISE SET FORTH IN ST'S TERMS AND CONDITIONS OF SALE ST DISCLAIMS ANY EXPRESS OR IMPLIED WARRANTY WITH RESPECT TO THE USE AND/OR SALE OF ST PRODUCTS INCLUDING WITHOUT LIMITATION IMPLIED WARRANTIES OF MERCHANTABILITY, FITNESS FOR A PARTICULAR PURPOSE (AND THEIR EQUIVALENTS UNDER THE LAWS OF ANY JURISDICTION), OR INFRINGEMENT OF ANY PATENT, COPYRIGHT OR OTHER INTELLECTUAL PROPERTY RIGHT.

UNLESS EXPRESSLY APPROVED IN WRITING BY TWO AUTHORIZED ST REPRESENTATIVES, ST PRODUCTS ARE NOT RECOMMENDED, AUTHORIZED OR WARRANTED FOR USE IN MILITARY, AIR CRAFT, SPACE, LIFE SAVING, OR LIFE SUSTAINING APPLICATIONS, NOR IN PRODUCTS OR SYSTEMS WHERE FAILURE OR MALFUNCTION MAY RESULT IN PERSONAL INJURY, DEATH, OR SEVERE PROPERTY OR ENVIRONMENTAL DAMAGE. ST PRODUCTS WHICH ARE NOT SPECIFIED AS "AUTOMOTIVE GRADE" MAY ONLY BE USED IN AUTOMOTIVE APPLICATIONS AT USER'S OWN RISK.

Resale of ST products with provisions different from the statements and/or technical features set forth in this document shall immediately void any warranty granted by ST for the ST product or service described herein and shall not create or extend in any manner whatsoever, any liability of ST.

ST and the ST logo are trademarks or registered trademarks of ST in various countries.

Information in this document supersedes and replaces all information previously supplied.

The ST logo is a registered trademark of STMicroelectronics. All other names are the property of their respective owners.

© 2012 STMicroelectronics - All rights reserved

STMicroelectronics group of companies

Australia - Belgium - Brazil - Canada - China - Czech Republic - Finland - France - Germany - Hong Kong - India - Israel - Italy - Japan - Malaysia - Malta - Morocco - Philippines - Singapore - Spain - Sweden - Switzerland - United Kingdom - United States of America

www.st.com

