

**isc Silicon PNP Darlington Power Transistor**

**BDW74/A/B/C/D**

**DESCRIPTION**

- Collector Current  $-I_C = -8A$
- High DC Current Gain  $-h_{FE} = 750(\text{Min.}) @ I_C = -3A$
- Complement to Type BDW73/A/B/C/D

**APPLICATIONS**

- Designed for audio output stages and general amplifier and switching applications

**ABSOLUTE MAXIMUM RATINGS( $T_a=25^\circ\text{C}$ )**

SYMBOL	PARAMETER	VALUE	UNIT	
$V_{CBO}$	Collector-Base Voltage	BDW74	-45	V
		BDW74A	-60	
		BDW74B	-80	
		BDW74C	-100	
		BDW74D	-120	
$V_{CEO}$	Collector-Emitter Voltage	BDW74	-45	V
		BDW74A	-60	
		BDW74B	-80	
		BDW74C	-100	
		BDW74D	-120	
$V_{EBO}$	Emitter-Base Voltage	-5	V	
$I_C$	Collector Current-Continuous	-8	A	
$I_B$	Base Current-Continuous	-0.3	A	
$P_C$	Collector Power Dissipation @ $T_a=25^\circ\text{C}$	2	W	
	Collector Power Dissipation @ $T_c=25^\circ\text{C}$	80		
$T_J$	Junction Temperature	150	$^\circ\text{C}$	
$T_{stg}$	Storage Temperature Range	-65~150	$^\circ\text{C}$	

**THERMAL CHARACTERISTICS**

SYMBOL	PARAMETER	MAX	UNIT
$R_{th\ j-c}$	Thermal Resistance, Junction to Case	1.56	$^\circ\text{C/W}$
$R_{th\ j-c}$	Thermal Resistance, Junction to Case	62.5	$^\circ\text{C/W}$

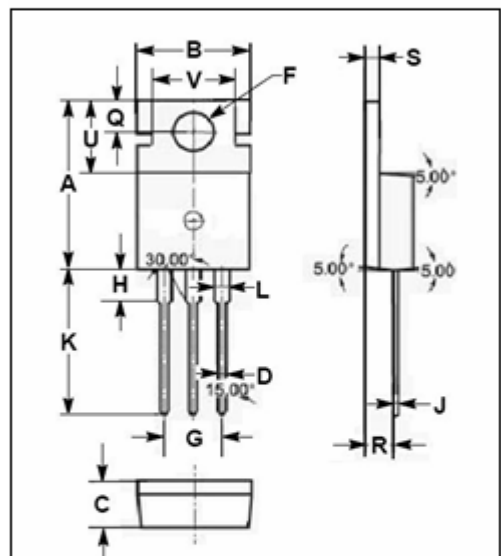
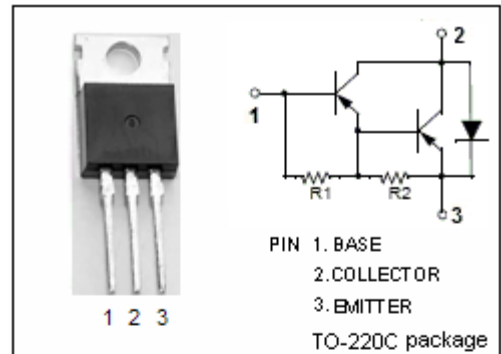

DIM	mm	
	MIN	MAX
A	15.70	15.90
B	9.90	10.10
C	4.20	4.40
D	0.70	0.90
F	3.40	3.60
G	4.98	5.18
H	2.70	2.90
J	0.44	0.46
K	13.20	13.40
L	1.10	1.30
Q	2.70	2.90
R	2.50	2.70
S	1.29	1.31
U	6.45	6.65
V	8.66	8.86

## isc Silicon PNP Darlington Power Transistor

## BDW74/A/B/C/D

## ELECTRICAL CHARACTERISTICS

 $T_C=25^\circ\text{C}$  unless otherwise specified

SYMBOL	PARAMETER		CONDITIONS	MIN	TYP.	MAX	UNIT
$V_{(BR)CEO}$	Collector-Emitter Breakdown Voltage	BDW74	$I_C = -30\text{mA}; I_B = 0$	-45			V
		BDW74A		-60			
		BDW74B		-80			
		BDW74C		-100			
		BDW74D		-120			
$V_{CE(sat)-1}$	Collector-Emitter Saturation Voltage		$I_C = -3\text{A}; I_B = -12\text{mA}$			-2.5	V
$V_{CE(sat)-2}$	Collector-Emitter Saturation Voltage		$I_C = -8\text{A}; I_B = -80\text{mA}$			-4.0	V
$V_{BE(on)}$	Base-Emitter On Voltage		$I_C = -3\text{A}; V_{CE} = -3\text{V}$			-2.5	V
$V_{ECF}$	C-E Diode Forward Voltage		$I_F = -8\text{A}$			-3.5	V
$I_{CEO}$	Collector Cutoff Current	BDW74	$V_{CE} = -30\text{V}; I_B = 0$			-0.5	mA
		BDW74A	$V_{CE} = -30\text{V}; I_B = 0$				
		BDW74B	$V_{CE} = -40\text{V}; I_B = 0$				
		BDW74C	$V_{CE} = -50\text{V}; I_B = 0$				
		BDW74D	$V_{CE} = -60\text{V}; I_B = 0$				
$I_{CBO}$	Collector Cutoff Current	BDW74	$V_{CB} = -45\text{V}; I_E = 0$ $V_{CB} = -45\text{V}; I_E = 0; T_J = 150^\circ\text{C}$			-0.2 -5.0	mA
		BDW74A	$V_{CB} = -60\text{V}; I_E = 0$ $V_{CB} = -60\text{V}; I_E = 0; T_J = 150^\circ\text{C}$			-0.2 -5.0	
		BDW74B	$V_{CB} = -80\text{V}; I_E = 0$ $V_{CB} = -80\text{V}; I_E = 0; T_J = 150^\circ\text{C}$			-0.2 -5.0	
		BDW74C	$V_{CB} = -100\text{V}; I_E = 0$ $V_{CB} = -100\text{V}; I_E = 0; T_J = 150^\circ\text{C}$			-0.2 -5.0	
		BDW74D	$V_{CB} = -120\text{V}; I_E = 0$ $V_{CB} = -120\text{V}; I_E = 0; T_J = 150^\circ\text{C}$			-0.2 -5.0	
$I_{EBO}$	Emitter Cutoff Current		$V_{EB} = -5\text{V}; I_C = 0$			-2.0	mA
$h_{FE-1}$	DC Current Gain		$I_C = -3\text{A}; V_{CE} = -3\text{V}$	750		20000	
$h_{FE-2}$	DC Current Gain		$I_C = -8\text{A}; V_{CE} = -3\text{V}$	100			
Switching times							
$t_{on}$	Turn-on Time		$I_C = -3\text{A}; I_{B1} = -I_{B2} = -12\text{mA};$ $V_{BE(off)} = 3.5\text{V}, R_L = 10\ \Omega$		1.0		$\mu\text{s}$
$t_{off}$	Turn-off Time				5.0		$\mu\text{s}$