

## Document Title

256Kx8 bit Low Power and Low Voltage CMOS Static RAM

## Revision History

<u>Revision No.</u>	<u>History</u>	<u>Draft Data</u>	<u>Remark</u>
0.0	Design target	May 26, 1998	Advance

---

The attached datasheets are provided by SAMSUNG Electronics. SAMSUNG Electronics CO., LTD. reserve the right to change the specifications and products. SAMSUNG Electronics will answer to your questions. If you have any questions, please contact the SAMSUNG branch offices.

---



# KM68V2000A, KM68U2000A Family

## 256Kx8 bit Low Power and Low Voltage CMOS Static RAM

### FEATURES

- Process Technology : TFT
- Organization : 256Kx8
- Power Supply Voltage
  - KM68V2000A Family : 3.0V ~ 3.6V
  - KM68U2000A Family : 2.7V ~ 3.3V
- Low Data Retention Voltage : 2V(Min)
- Three state output and TTL Compatible
- Package Type : 32-TSOP1-0820F, 32-TSOP1-0813.4F

### GENERAL DESCRIPTION

The KM68V2000A and KM68U2000A families are fabricated by SAMSUNG's advanced CMOS process technology. The family support various operating temperature ranges and have various package types for user flexibility of system design. The family also support low data retention voltage for battery back-up operation with low data retention current.

### PRODUCT FAMILY

Product Family	Operating Temperature	Vcc Range	Speed(ns)	Power Dissipation		PKG Type
				Standby (I <sub>SB1</sub> , Max)	Operating (I <sub>CC2</sub> , Max)	
KM68V2000AL-L	Commercial(0~70°C)	3.0~3.6V	70/85	10μA	30mA <sup>2)</sup>	32-TSOP1-0820F 32-TSOP1-0813.4F
KM68U2000AL-L		2.7~3.3V	70 <sup>1)</sup> /100			
KM68V2000ALI-L	Industrial(-40~85°C)	3.0~3.6V	70 <sup>1)</sup> /100	15μA		
KM68U2000ALI-L		2.7~3.3V	70 <sup>1)</sup> /100			

1. The parameters are tested with 30pF test load
2. KM68V2000A Family = 35mA

### PIN DESCRIPTION

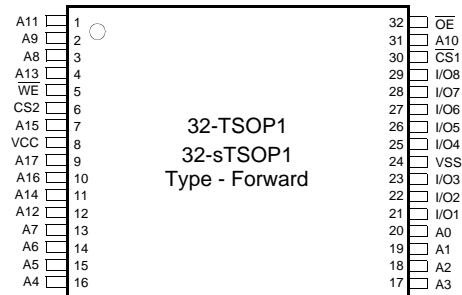

Name	Function
$\overline{CS}_1, \overline{CS}_2$	Chip Select Input
$\overline{OE}$	Output Enable Input
$\overline{WE}$	Write Enable Input
A0~A17	Address Inputs
I/O1~I/O8	Data Inputs/Outputs
Vcc	Power
Vss	Ground
N.C.	No Connection

### FUNCTIONAL BLOCK DIAGRAM

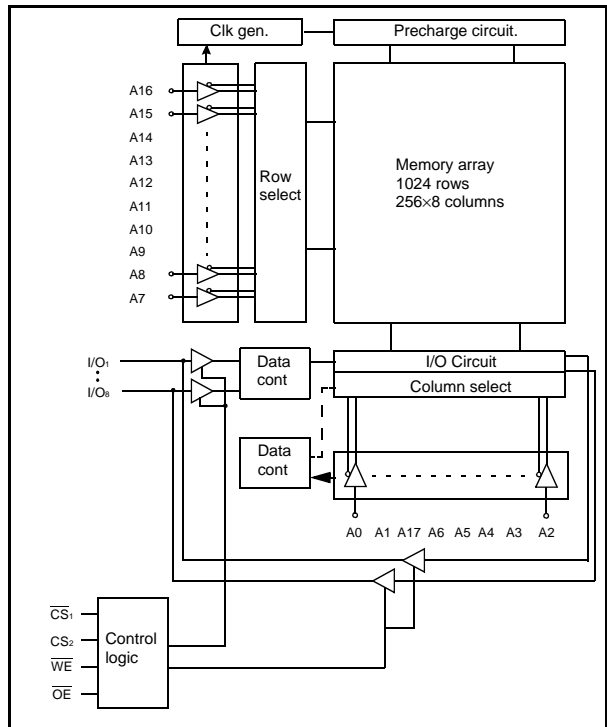

SAMSUNG ELECTRONICS CO., LTD. reserves the right to change products and specifications without notice.

## KM68V2000A, KM68U2000A Family

### PRODUCT LIST

Commercial Temperature Products(0~70°C)		Industrial Temperature Products(-40~85°C)	
Part Name	Function	Part Name	Function
KM68V2000ALT-7L KM68V2000ALT-8L	32-TSOP1 F, 70ns, 3.3V,LL 32-TSOP1 F, 85ns, 3.3V,LL	KM68V2000ALTI-7L KM68V2000ALTI-10L	32-TSOP1 F, 70ns, 3.3V,LL 32-TSOP1 F, 100ns, 3.3V,LL
KM68U2000ALT-7L KM68U2000ALT-10L	32-TSOP1 F, 70ns, 3.0V, LL 32-TSOP1 F, 100ns, 3.0V, LL	KM68U2000ALTI-7L KM68U2000ALTI-10L	32-TSOP1 F, 70ns, 3.0V, LL 32-TSOP1 F, 100ns, 3.0V, LL
KM68V2000ALTG-7L KM68V2000ALTG-8L	32-sTSOP1 F, 70ns, 3.3V,LL 32-sTSOP1 F, 85ns, 3.3V,LL	KM68V2000ALTGI-7L KM68V2000ALTGI-10L	32-sTSOP1 F, 70ns, 3.3V,LL 32-sTSOP1 F, 100ns, 3.3V,LL
KM68U2000ALTG-7L KM68U2000ALTG-10L	32-sTSOP1 F, 70ns, 3.0V, LL 32-sTSOP1 F, 100ns, 3.0V, LL	KM68U2000ALTGI-7L KM68U2000ALTGI-10L	32-sTSOP1 F, 70ns, 3.0V, LL 32-sTSOP1 F, 100ns, 3.0V, LL

### FUNCTIONAL DESCRIPTION

$\overline{CS}_1$	$CS_2$	$\overline{OE}$	$\overline{WE}$	I/O	Mode	Power
H	X <sup>1)</sup>	X <sup>1)</sup>	X <sup>1)</sup>	High-Z	Deselected	Standby
X <sup>1)</sup>	L	X <sup>1)</sup>	X <sup>1)</sup>	High-Z	Deselected	Standby
L	H	H	H	High-Z	Output Disabled	Active
L	H	L	H	Dout	Read	Active
L	H	X <sup>1)</sup>	L	Din	Write	Active

1. X means don't care (Must be in high or low states)

### ABSOLUTE MAXIMUM RATINGS<sup>1)</sup>

Item	Symbol	Ratings	Unit	Remark
Voltage on any pin relative to Vss	V <sub>IN</sub> ,V <sub>OUT</sub>	-0.5 to V <sub>CC</sub> +0.5	V	-
Voltage on Vcc supply relative to Vss	V <sub>CC</sub>	-0.3 to 4.6	V	-
Power Dissipation	P <sub>D</sub>	1.0	W	-
Storage temperature	T <sub>STG</sub>	-65 to 150	°C	-
Operating Temperature	T <sub>A</sub>	0 to 70	°C	KM68V2000AL, KM68U2000AL
		-40 to 85	°C	KM68V2000ALI, KM68U2000ALI

1. Stresses greater than those listed under "Absolute Maximum Ratings" may cause permanent damage to the device. Functional operation should be restricted to recommended operating condition. Exposure to absolute maximum rating conditions for extended periods may affect reliability.

# KM68V2000A, KM68U2000A Family

## RECOMMENDED DC OPERATING CONDITIONS<sup>1)</sup>

Item	Symbol	Product	Min	Typ	Max	Unit
Supply voltage	V <sub>CC</sub>	KM68V2000A Family KM68U2000A Family	3.0 2.7	3.3 3.0	3.6 3.3	V
Ground	V <sub>SS</sub>	All Family	0	0	0	V
Input high voltage	V <sub>IH</sub>	KM68V2000A, KM68U2000A Family	2.2	-	V <sub>CC</sub> +0.3	V
Input low voltage	V <sub>IL</sub>	KM68V2000A, KM68U2000A Family	-0.3 <sup>3)</sup>	-	0.6	V

Note:

- Commercial Product : T<sub>A</sub>=0 to 70°C, otherwise specified  
Industrial Product : T<sub>A</sub>=-40 to 85°C, otherwise specified
- Overshoot : V<sub>CC</sub>+3.0V in case of pulse width≤30ns
- Undershoot : -3.0V in case of pulse width≤30ns
- Overshoot and undershoot are sampled, not 100% tested.

## CAPACITANCE<sup>1)</sup> (f=1MHz, T<sub>A</sub>=25°C)

Item	Symbol	Test Condition	Min	Max	Unit
Input capacitance	C <sub>IN</sub>	V <sub>IN</sub> =0V	-	8	pF
Input/Output capacitance	C <sub>IO</sub>	V <sub>IO</sub> =0V	-	10	pF

- Capacitance is sampled, not 100% tested

## DC AND OPERATING CHARACTERISTICS

Item	Symbol	Test Conditions	Min	Typ	Max	Unit
Input leakage current	I <sub>LI</sub>	V <sub>IN</sub> =V <sub>SS</sub> to V <sub>CC</sub>	-1	-	1	μA
Output leakage current	I <sub>LO</sub>	$\overline{CS}_1=V_{IH}$ or $CS_2=V_{IL}$ or $\overline{OE}=V_{IH}$ or $\overline{WE}=V_{IL}$ , V <sub>IO</sub> =V <sub>SS</sub> to V <sub>CC</sub>	-1	-	1	μA
Operating power supply current	I <sub>CC</sub>	I <sub>IO</sub> =0mA, $\overline{CS}_1=V_{IL}$ , CS <sub>2</sub> =V <sub>IH</sub> , V <sub>IN</sub> =V <sub>IH</sub> or V <sub>IL</sub>	-	-	5	mA
Average operating current	I <sub>CC1</sub>	Cycle time=1μs, 100%duty, I <sub>IO</sub> =0mA, $\overline{CS}_1\leq 0.2V$ , CS <sub>2</sub> ≥V <sub>CC</sub> -0.2V, V <sub>IN</sub> ≤0.2V	-	-	3	mA
	I <sub>CC2</sub>	Cycle time=Min, 100% duty, I <sub>IO</sub> =0mA, $\overline{CS}_1=V_{IL}$ , CS <sub>2</sub> =V <sub>IH</sub> , V <sub>IN</sub> =V <sub>IH</sub> or V <sub>IL</sub>	-	25	30 <sup>1)</sup>	mA
Output low voltage	V <sub>OL</sub>	I <sub>OL</sub> =2.1mA	-	-	0.4	V
Output high voltage	V <sub>OH</sub>	I <sub>OH</sub> =-1.0mA	2.4	-	-	V
Standby Current(TTL)	I <sub>SB</sub>	$\overline{CS}_1=V_{IH}$ , CS <sub>2</sub> =V <sub>IL</sub> , Other inputs=V <sub>IH</sub> or V <sub>IL</sub>	-	-	0.3	mA
Standby Current(CMOS)	I <sub>SB1</sub>	$\overline{CS}_1\geq V_{CC}-0.2V$ , CS <sub>2</sub> ≥V <sub>CC</sub> -0.2V or CS <sub>2</sub> ≤0.2V, Other inputs=0-V <sub>CC</sub>	-	0.2	10 <sup>2)</sup>	μA

- KM68V2000A Family = 35mA
- Industrial product = 15μA

# KM68V2000A, KM68U2000A Family

## AC OPERATING CONDITIONS

### TEST CONDITIONS (Test Load and Input/Output Reference)

Input pulse level : 0.4 to 2.2V  
 Input rising and falling time : 5ns  
 Input and output reference voltage : 1.5V  
 Output load(see right) :  $C_L=100\text{pF}+1\text{TTL}$   
 $C_L=30\text{pF}+1\text{TTL}$

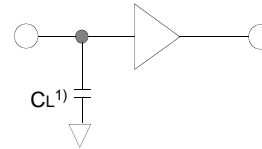

1. Including scope and jig capacitance

## AC CHARACTERISTICS (KM68V2000A Family : $V_{CC}=3.0\sim 3.6\text{V}$ , KM68U2000A Family : $V_{CC}=2.7\sim 3.3\text{V}$ Commercial Product : $T_A=0$ to $70^\circ\text{C}$ , Industrial Product : $T_A=-40$ to $85^\circ\text{C}$ )

Parameter List		Symbol	Speed Bins						Units
			70ns		85ns		100ns		
			Min	Max	Min	Max	Min	Max	
Read	Read cycle time	t <sub>RC</sub>	70	-	85	-	100	-	ns
	Address access time	t <sub>AA</sub>	-	70	-	85	-	100	ns
	Chip select to output	t <sub>CO1</sub> , t <sub>CO2</sub>	-	70	-	85	-	100	ns
	Output enable to valid output	t <sub>OE</sub>	-	35	-	40	-	50	ns
	Chip select to low-Z output	t <sub>LZ</sub>	10	-	10	-	10	-	ns
	Output enable to low-Z output	t <sub>OLZ</sub>	5	-	5	-	5	-	ns
	Chip disable to high-Z output	t <sub>HZ</sub>	0	25	0	25	0	30	ns
	Output disable to high-Z output	t <sub>OHZ</sub>	0	25	0	25	0	30	ns
	Output hold from address change	t <sub>OH</sub>	10	-	15	-	15	-	ns
Write	Write cycle time	t <sub>WC</sub>	70	-	85	-	100	-	ns
	Chip select to end of write	t <sub>CW</sub>	60	-	70	-	80	-	ns
	Address set-up time	t <sub>AS</sub>	0	-	0	-	0	-	ns
	Address valid to end of write	t <sub>AW</sub>	60	-	70	-	80	-	ns
	Write pulse width	t <sub>WP</sub>	55	-	60	-	70	-	ns
	Write recovery time	t <sub>WR</sub>	0	-	0	-	0	-	ns
	Write to output high-Z	t <sub>WHZ</sub>	0	25	0	30	0	30	ns
	Data to write time overlap	t <sub>DW</sub>	30	-	35	-	40	-	ns
	Data hold from write time	t <sub>DH</sub>	0	-	0	-	0	-	ns
	End write to output low-Z	t <sub>OW</sub>	5	-	5	-	5	-	ns

## DATA RETENTION CHARACTERISTICS

Item	Symbol	Test Condition	Min	Typ	Max	Unit
V <sub>CC</sub> for data retention	V <sub>DR</sub>	$\overline{CS}_1 \geq V_{CC}-0.2\text{V}^{(1)}$	2.0	-	3.6	V
Data retention current	I <sub>DR</sub>	$V_{CC}=3.0\text{V}$ , $\overline{CS}_1 \geq V_{CC}-0.2\text{V}^{(1)}$	-	0.2	10 <sup>(2)</sup>	μA
Data retention set-up time	t <sub>SDR</sub>	See data retention waveform	0	-	-	ms
Recovery time	t <sub>RDR</sub>		5	-	-	

1.  $\overline{CS}_1 \geq V_{CC}-0.2\text{V}$ ,  $CS_2 \geq V_{CC}-0.2\text{V}$  ( $\overline{CS}_1$  controlled) or  $CS_2 \leq 0.2\text{V}$  ( $CS_2$  controlled)

2. Industrial Products = 15μA

# KM68V2000A, KM68U2000A Family

## TIMMING DIAGRAMS

**TIMING WAVEFORM OF READ CYCLE(1)** (Address Controlled,  $\overline{CS}_1 = \overline{OE} = V_{IL}$ ,  $CS_2 = \overline{WE} = V_{IH}$ )

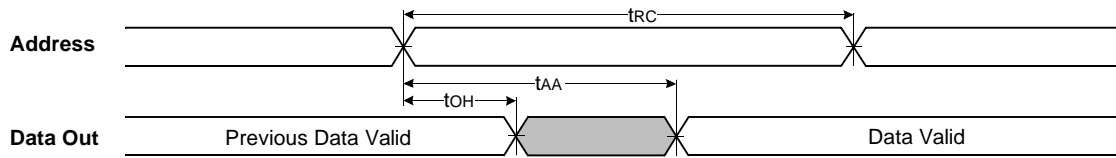

**TIMING WAVEFORM OF READ CYCLE(2)** ( $\overline{WE} = V_{IH}$ )

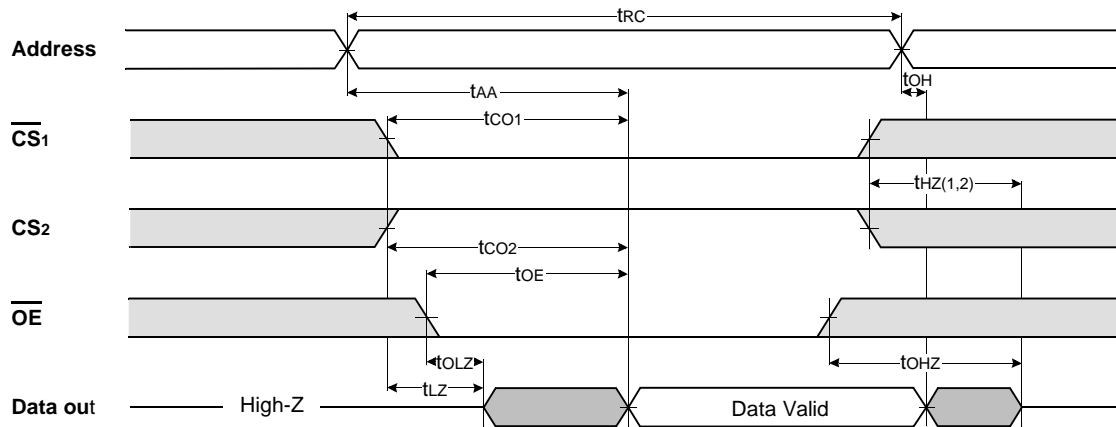

**NOTES (READ CYCLE)**

1.  $t_{HZ}$  and  $t_{OHZ}$  are defined as the time at which the outputs achieve the open circuit conditions and are not referenced to output voltage levels.
2. At any given temperature and voltage condition,  $t_{HZ}(\text{Max.})$  is less than  $t_{LZ}(\text{Min.})$  both for a given device and from device to device interconnection.

**TIMING WAVEFORM OF WRITE CYCLE(1) ( $\overline{WE}$  Controlled)**

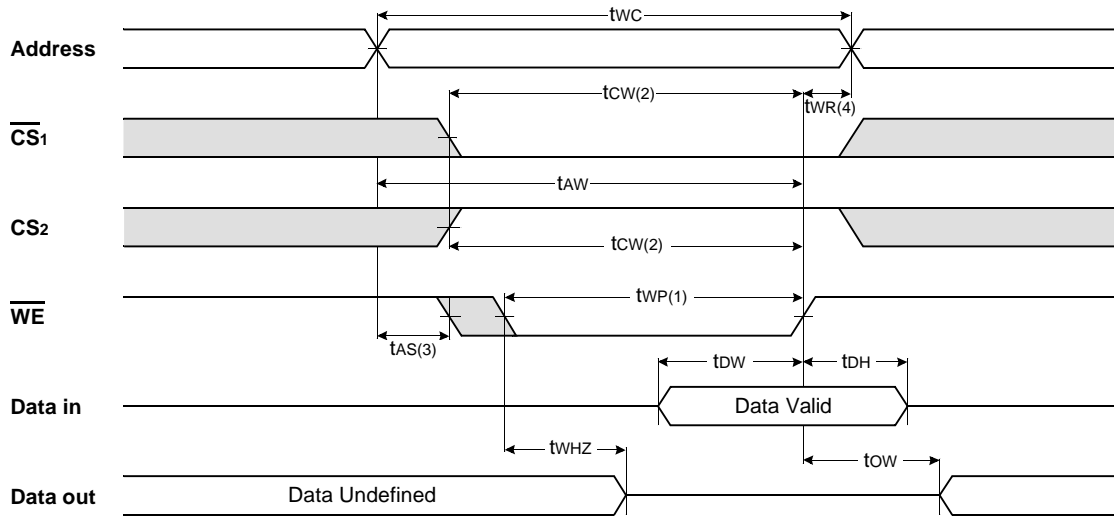

**TIMING WAVEFORM OF WRITE CYCLE(2) ( $\overline{CS1}$  Controlled)**

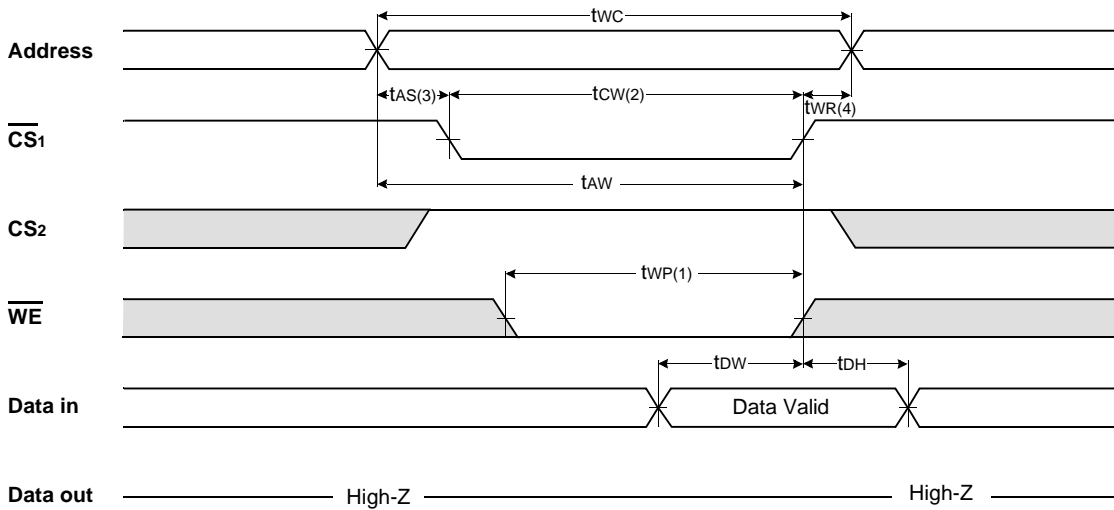

## TIMING WAVEFORM OF WRITE CYCLE(3) (CS<sub>2</sub> Controlled)

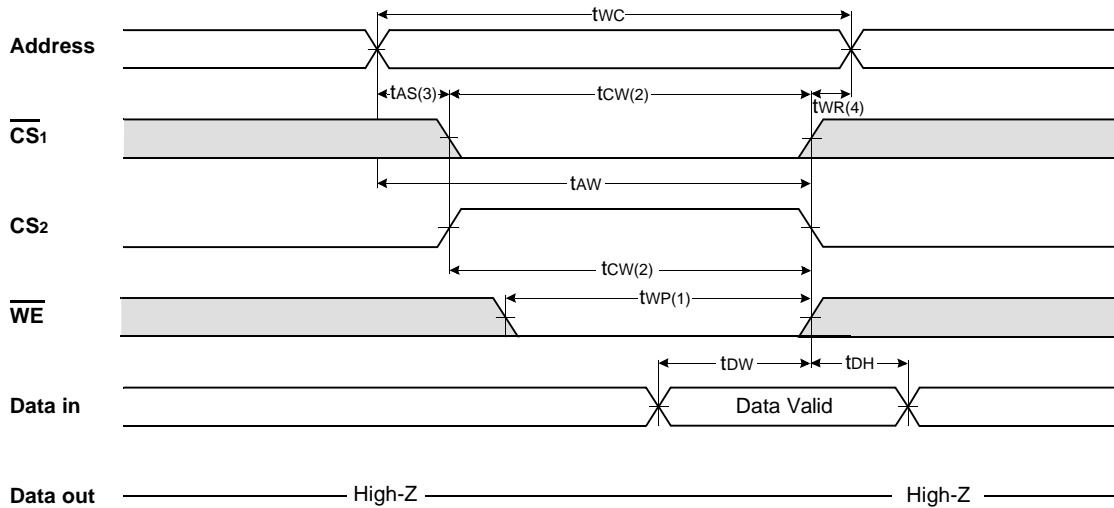

### NOTES (WRITE CYCLE)

1. A write occurs during the overlap of a low  $\overline{CS}_1$ , a high  $CS_2$  and a low  $\overline{WE}$ . A write begins at the latest transition among  $\overline{CS}_1$  goes low,  $CS_2$  going high and  $\overline{WE}$  going low : A write ends at the earliest transition among  $\overline{CS}_1$  going high,  $CS_2$  going low and  $\overline{WE}$  going high,  $t_{WP}$  is measured from the beginning of write to the end of write.
2.  $t_{CW}$  is measured from the  $\overline{CS}_1$  going low or  $CS_2$  going high to the end of write.
3.  $t_{AS}$  is measured from the address valid to the beginning of write.
4.  $t_{WR}$  is measured from the end of write to the address change.  $t_{WR1}$  applied in case a write ends as  $\overline{CS}_1$  or  $\overline{WE}$  going high  $t_{WR2}$  applied in case a write ends as  $CS_2$  going to low.

## DATA RETENTION WAVE FORM

### $\overline{CS}_1$ controlled

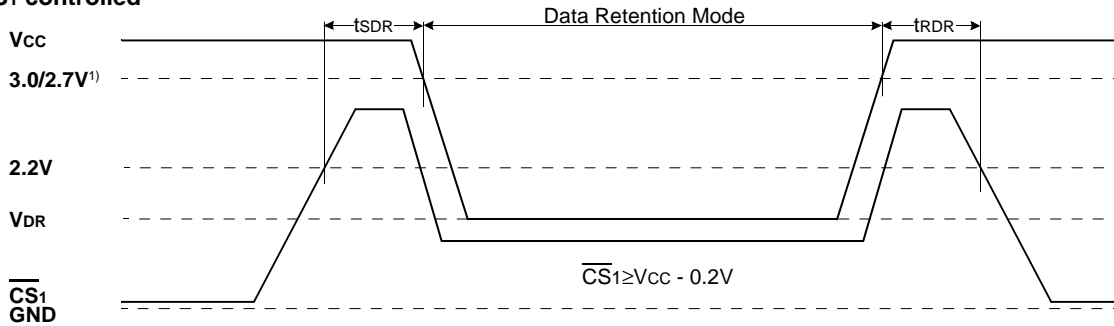

### $CS_2$ controlled

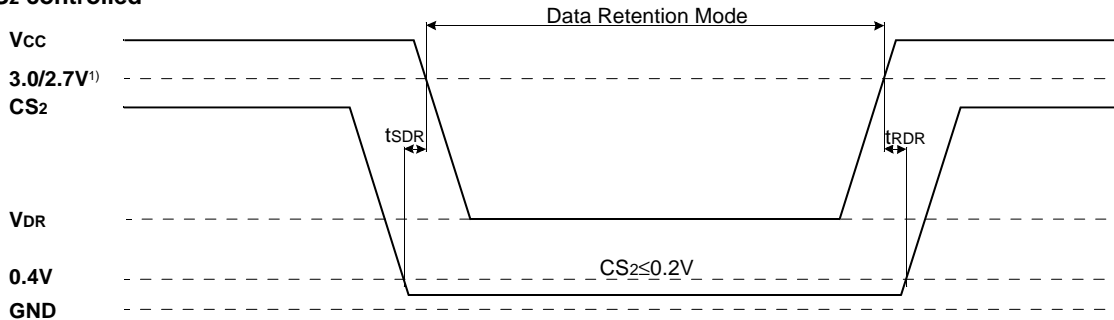

1. 3.0V for KM68V2000A Family, 2.7V for KM68U2000A Family



**KM68V2000A, KM68U2000A Family**

**PACKAGE DIMENSIONS**

Units : millimeter(inch)

**32 PIN THIN SMALL OUTLINE PACKAGE TYPE I (0820F)**

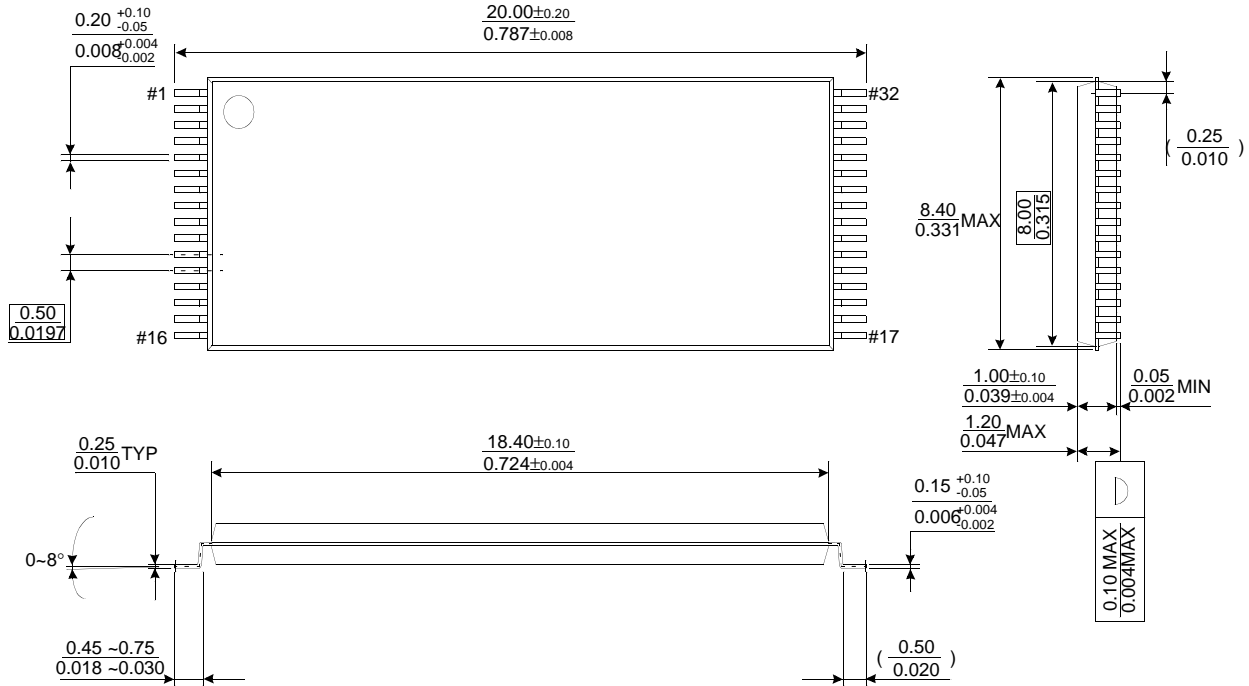

**32 PIN SMALLER THIN SMALL OUTLINE PACKAGE TYPE I (0813.4F)**

