

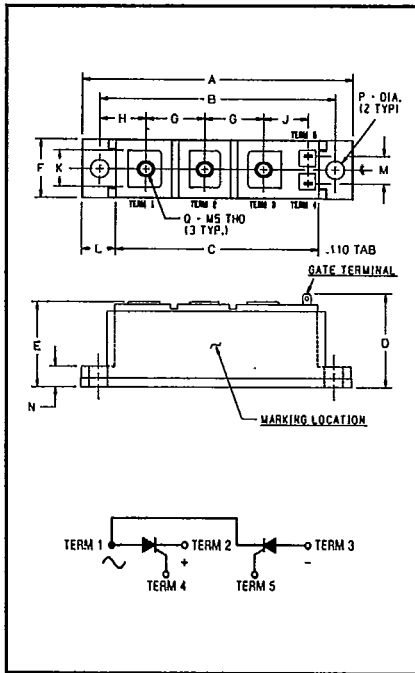

Powerex, Inc., Hills Street, Youngwood, Pennsylvania 15697 (412) 925-7272  
 Powerex Europe, S.A., 428 Avenue G. Durand, BP107, 72003 Le Mans, France (43) 72.75.15

CD4A \_\_\_ 90

**Dual SCR**  
**POW-R-BLOK™ Module**  
**90 Amperes/1200-1600 Volts**



**1200-1600 Volts CD4A \_\_\_ 90**  
**Outline Drawing**

Dimension	Inches		Millimeters	
	Min.	Max.	Min.	Max.
A	3.602	3.640	91.49	92.45
B	3.146	3.154	79.91	80.11
C	2.705	2.735	68.71	69.47
D	1.24	1.28	31.50	32.51
E	1.125	1.165	28.58	29.59
F	.795	.805	20.19	20.45
G	.788	.798	19.76	20.27
H	.608	.628	15.44	15.95
J	.585	.605	14.86	15.36
K	.480	.520	12.19	13.21
L	.43	.47	10.92	11.94
M	.36	.40	9.14	10.16
N	.265	.285	6.73	7.24
P	.245	.255	6.22	6.48
Q	—	—	M5 x 0.8	

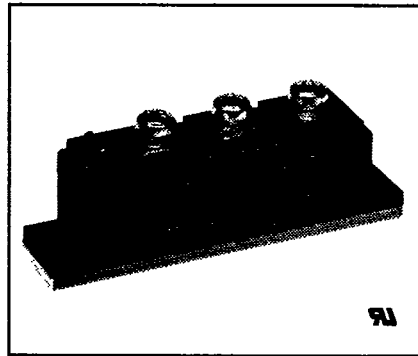

**CD4A \_\_\_ 90**  
**Dual SCR POW-R-BLOK™ Module**  
 90 Amperes/1200-1600 Volts

**Ordering Information**

Example: Select the complete eight digit rating module part number you desire from the table — i.e. CD4A1290 is a 1200 Volt, 90 Ampere Dual SCR POW-R-BLOK™ Module.

Type	V <sub>RRM</sub> Volts (x100)	Current Rating Amperes (90)
CD4A	12	90
	14	
	16	

**Description**

Powerex Dual SCR POW-R-BLOK™ Modules combine multiple power semiconductor devices in a single, electrically isolated module. This dense, cost-effective packaging is made possible by Powerex's proprietary *glass passivation* process, in which each semiconductor junction is sealed with a protective layer of glass. Exhaustive testing at high voltages and high temperatures has demonstrated the excellent parameter stability of these glass-protected products.

The POW-R-BLOK™ features a self-contained electrical isolation system. The use of BeO ceramic isolators with high thermal conductivity has achieved excellent circuit-to-baseplate isolation ( $\geq 2500$  volts RMS), while maintaining efficient cooling of the semiconductors. POW-R-BLOK™ has been tested and recognized by Underwriters Laboratories (QQX2 Power Switching Semiconductors).

**Features:**

- Glass Passivated Chips
- Hybrid Construction
- Isolated Base Plate
- Low Thermal Impedance
- Metal Base Plate
- UL Recognized
- Quick Connect Gate Terminals
- High dv/dt
- Low Gate Sensitivity

**Applications:**

- Motor Speed Control
- Battery Chargers
- Tap Changers
- Transfer Switches
- Lighting Controls
- Power Line Applications of 120, 240 or 480 Volts

**Benefits:**

- No Additional Insulating Components Required
- Easy Installation
- Reduced Engineering Time
- Improved Heat Transfer
- Voltage Stability



Powerex, Inc., Hillis Street, Youngwood, Pennsylvania 15697 (412) 925-7272  
 Powerex Europe, S.A., 428 Avenue G. Durand, BP107, 72003 Le Mans, France (43) 72.75.15

CD4A — 90  
 Dual SCR POW-R-BLOK™ Module  
 90 Amperes/1200-1600 Volts

### Absolute Maximum Ratings

Characteristics	Symbol	CD4A1290	CD4A1490	CD4A1690	Units
Peak Forward Blocking Voltage	$V_{DRM}$	1200	1400	1600	Volts
Peak Reverse Blocking Voltage	$V_{RRM}$	1200	1400	1600	Volts
Transient Peak Reverse Blocking Voltage (Non-Repetitive) $t < 5$ ms	$V_{RSM}$	1450	1700	1950	Volts



Powerex, Inc., Hillis Street, Youngwood, Pennsylvania 15697 (412) 925-7272

Powerex Europe, S.A., 428 Avenue G. Durand, BP107, 72003 Le Mans, France (43) 72.75.15

CD4A \_\_\_ 90  
Dual SCR POW-R-BLOK™ Module  
90 Amperes/1200-1600 Volts

### Absolute Maximum Ratings

Characteristics	Symbol	CD4A ___ 90	Units
RMS On-State Current	$I_{T(RMS)}$	145	Amperes
Average On-State Current	$I_{T(AV)}$	90	Amperes
Peak One-Cycle Surge (Non-Repetitive) On-State Current (60Hz)	$I_{TSM}$	1925	Amperes
Peak Three-Cycle Surge (Non-Repetitive) On-State Current (60Hz)	$I_{TSM}$	1390	Amperes
Peak Ten-Cycle Surge (Non-Repetitive) On-State Current (60Hz)	$I_{TSM}$	1250	Amperes
Peak One-Cycle Surge (Non-Repetitive) On-State Current (50Hz)	$I_{TSM}$	1755	Amperes
$I^2t$ (for Fusing), 8.3 milliseconds	$I^2t$	15375	A <sup>2</sup> sec
Critical Rate-of-Rise of On-State Current $\text{\textcircled{1}}$ (Non-Repetitive)	$di/dt$	800	Amperes/ $\mu$ s
Peak Gate Power Dissipation	$P_{GM}$	16	Watts
Average Gate Power Dissipation	$P_{G(AV)}$	3.0	Watts
Peak Forward Gate Voltage	$V_{GFM}$	10	Volts
Peak Reverse Gate Voltage	$V_{GRM}$	5.0	Volts
Peak Forward Gate Current	$I_{GFM}$	4.0	Amperes
Storage Temperature	$T_{STG}$	-40 to 150	°C
Operating Temperature	$T_J$	-40 to 125	°C
Maximum Mounting Torque M6 Mounting Screw	—	50	in.-lb.
Maximum Terminal Torque M5 Terminal Screw	—	35	in.-lb.
Module Weight (Typical)	—	142	Grams
V Isolation	$V_{RMS}$	2500	Volts

$\text{\textcircled{1}}$  Per JEDEC STD RS-397, 5.2.26.



Powerex, Inc., Hillis Street, Youngwood, Pennsylvania 15697 (412) 925-7272

Powerex Europe, S.A., 428 Avenue G. Durand, BP107, 72003 Le Mans, France (43) 72.75.15

CD4A \_\_\_ 90  
Dual SCR POW-R-BLOK™ Module  
90 Amperes/1200-1600 Volts

### Electrical and Thermal Characteristics, $T_J = 25^\circ\text{C}$ unless otherwise specified

Characteristic	Symbol	Test Conditions	CD4A ___ 90	Units
<b>Blocking State Maximums</b>				
Forward Leakage Current, Peak	$I_{\text{DRM}}$	$T_J = 125^\circ\text{C}$ , $V_{\text{DRM}} = \text{rated}$	15	mA
Reverse Leakage Current, Peak	$I_{\text{RRM}}$	$T_J = 125^\circ\text{C}$ , $V_{\text{RRM}} = \text{rated}$	15	mA
<b>Conducting State Maximums</b>				
Peak On-State Voltage	$V_{\text{TM}}$	$I_{\text{TM}} = 250\text{A}$	1.55	Volts
<b>Switching Minimums</b>				
Critical Rate of Rise of Off-State Voltage	dv/dt	$T_J = 125^\circ\text{C}$ , Exponential to $V_{\text{DRM}}$	1000	Volts/ $\mu\text{sec}$
Typical Turn-Off Time	$t_q$	$I_{\text{TM}} = 50\text{A}$ , $T_J = 125^\circ\text{C}$ , $di_p/dt = 5\text{A}/\mu\text{s}$ reapplied dv/dt = $20\text{V}/\mu\text{s}$ linear to $0.8 V_{\text{DRM}}$	100	$\mu\text{sec}$
Typical Turn-On Time	$t_{\text{on}}$	$I_{\text{TM}} = 100\text{A}$ , $V_D = 100\text{V}$	4	$\mu\text{sec}$
<b>Thermal Maximums</b>				
Thermal Resistance, Junction to Case	$R_{\theta\text{JC}}$	Per Device	0.28	$^\circ\text{C}/\text{Watt}$
Thermal Resistance, Case to Sink Lubricated	$R_{\theta\text{CS}}$	Per Device	0.2	$^\circ\text{C}/\text{Watt}$
<b>Gate Parameters Maximums</b>				
Gate Current to Trigger	$I_{\text{GT}}$	$V_D = 12\text{V}$	100	mA
Gate Voltage to Trigger	$V_{\text{GT}}$	$V_D = 12\text{V}$	3.0	Volts
Non-Triggering Gate Voltage	$V_{\text{GDM}}$	$T_J = 125^\circ\text{C}$ , $V_D = V_{\text{DRM}}$	0.15	Volts

#### WARNING:

Internal insulation used is Beryllium Oxide. User should avoid grinding, crushing or abrading these portions. Care must be exercised in properly disposing of unwanted modules.



Powerex, Inc., Hillis Street, Youngwood, Pennsylvania 15697 (412) 925-7272  
 Powerex Europe, S.A., 428 Avenue G. Durand, BP107, 72003 Le Mans, France (43) 72.75.15

CD4A 90  
 Dual SCR POW-R-BLOK™ Module  
 90 Amperes/1200-1600 Volts

MAXIMUM ON-STATE CHARACTERISTICS

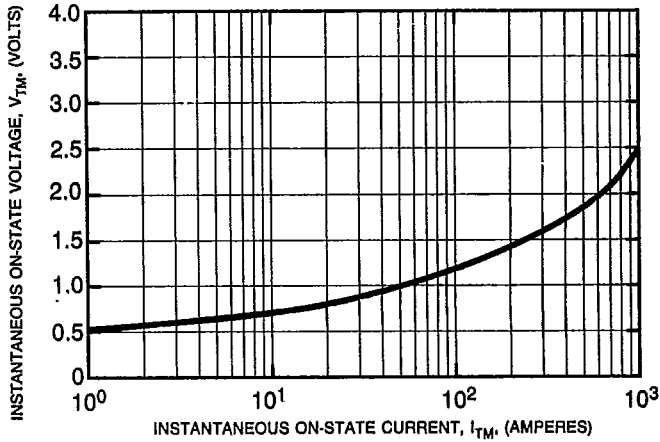

TRANSIENT THERMAL IMPEDANCE CHARACTERISTICS (JUNCTION TO CASE)

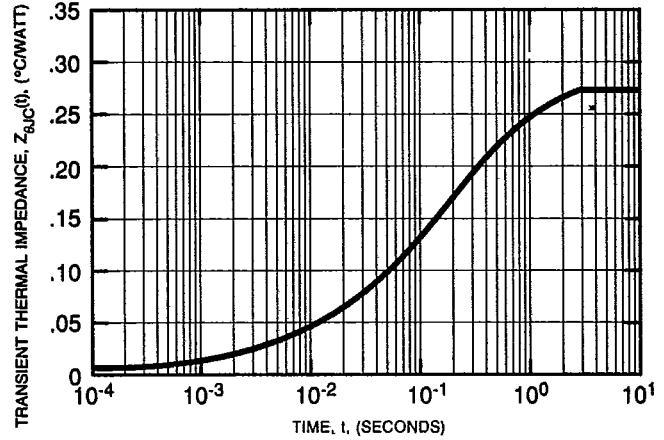

MAXIMUM ALLOWABLE CASE TEMPERATURE

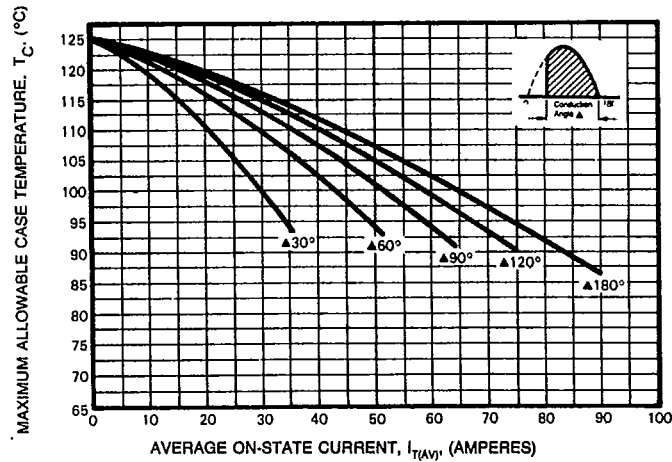

MAXIMUM ALLOWABLE CASE TEMPERATURE

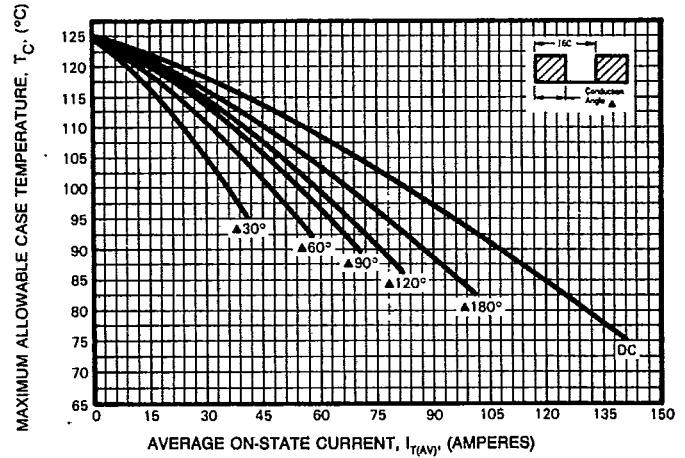

MAXIMUM ON-STATE POWER DISSIPATION

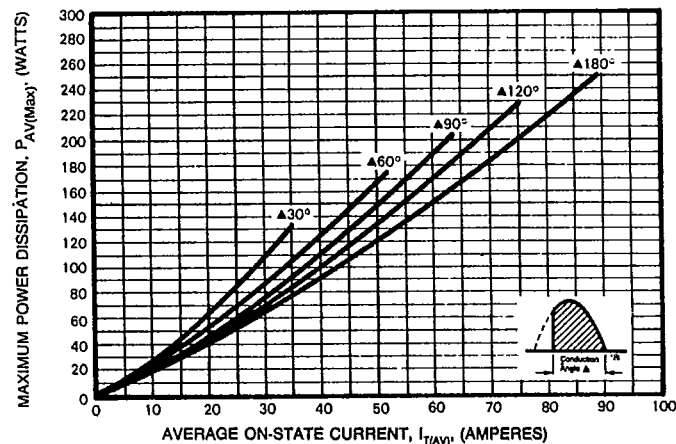

MAXIMUM ON-STATE POWER DISSIPATION

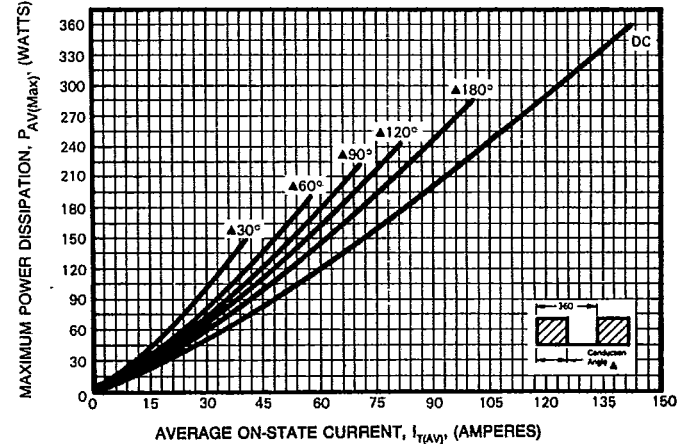



Powerex, Inc., Hillis Street, Youngwood, Pennsylvania 15697 (412) 925-7272

Powerex Europe, S.A., 428 Avenue G. Durand, BP107, 72003 Le Mans, France (43) 72.75.15

CD4A — 90  
Dual SCR POW-R-BLOK™ Module  
90 Amperes/1200-1600 Volts

**MAXIMUM TOTAL POWER DISSIPATION AND MAXIMUM AMBIENT TEMPERATURES**

AC SWITCH

1 CD4A — 90

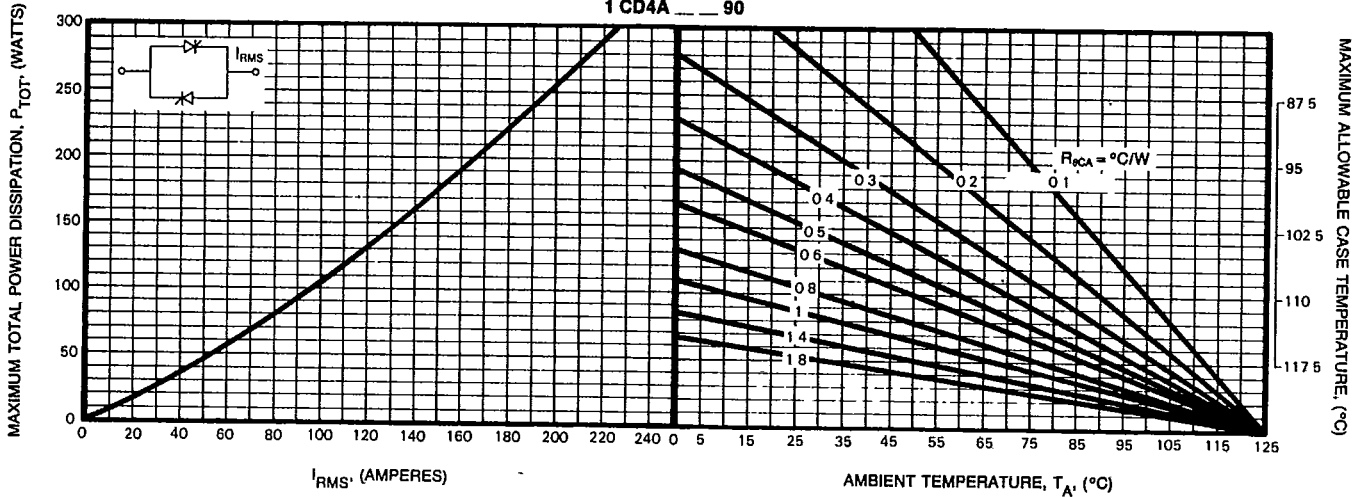

1φ—BRIDGE RESISTIVE AND INDUCTIVE LOAD

2 CD4A — 90

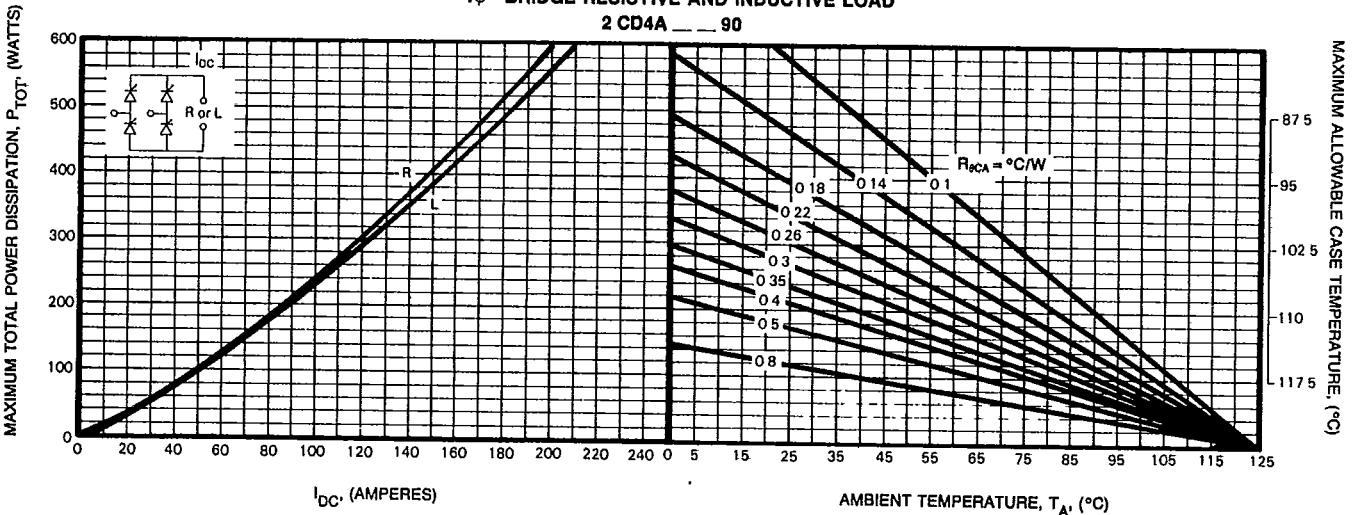

3φ—BRIDGE AND AC SWITCH

3 CD4A — 90

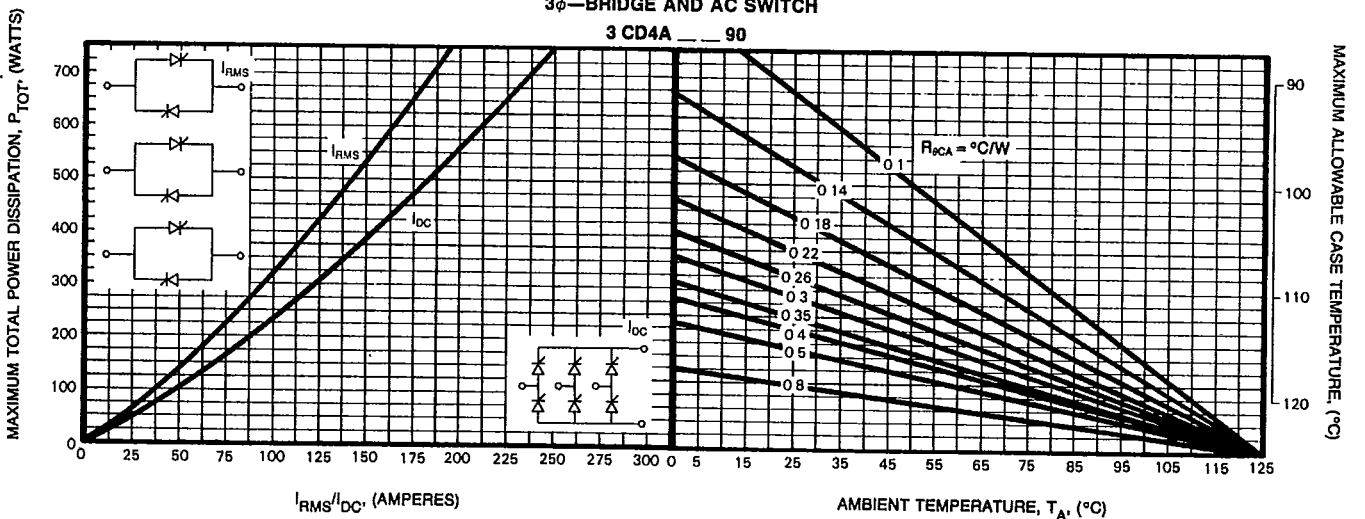



T-91-01

Powerex, Inc., Hillis Street, Youngwood, Pennsylvania 15697 (412) 925-7272  
 Powerex Europe, S.A., 428 Avenue G. Durand, BP107, 72003 Le Mans, France (43) 41.14.14

## Taping

### STANDARD SPECIFICATIONS FOR TAPING OF MOLDED PACKAGE THYRISTORS AND TRIACS

#### TO-92 Package

Thyristor  
CR02AM, CR03AM, CR04AM  
Triac  
BCR1AM

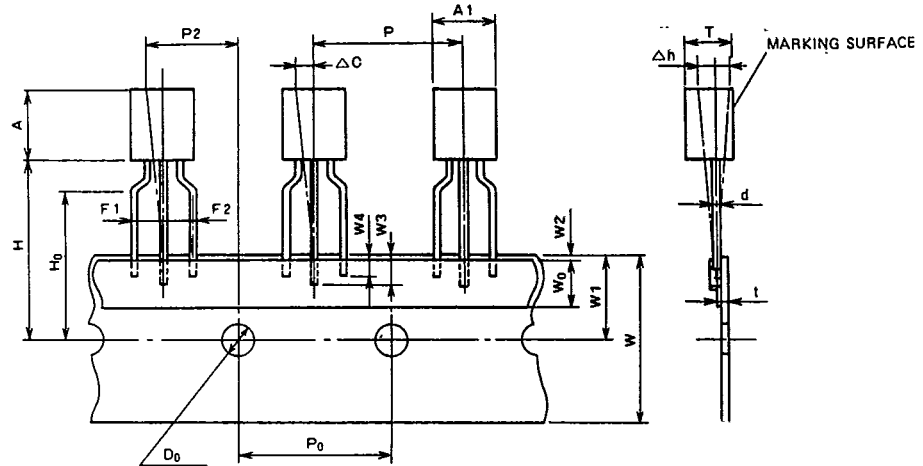

Taping dimensions

Description of symbol	Symbol	Dimensions (Unit:mm)	Remark
Product width	A1	5.0 MAX	
Product height	A	5.0 MAX	
Product thickness	T	3.7 MAX	
Lead wire diameter	d	0.6 MAX	
Sticker lead wire length (1)	W3	2.5 MIN	
Sticker lead wire length (2)	W4	2.0 MIN	
Pitch between products	P	12.7 ± 1.0	
Feed hole pitch	P <sub>0</sub>	12.7 ± 0.3	The cumulative pitch error is ± 1mm per 20 pitches.
Feed hole deviation (1)	P2	6.35 ± 1.3	
Distance between lead wires	F1, F2	2.5 ± 0.4	
Defective product (1)	Δh	0 ± 2.0	
Tape width	W	18.0 ± <sup>1.0</sup> / <sub>0.5</sub>	
Sticker tape width	W <sub>0</sub>	6.0 ± 0.5	
Feed hole deviation (2)	W1	9.0 ± 0.5	
Sticker tape deviation	W2	0.5 MAX	
Position of product bottom surface	H	17.5 MIN	
Lynch height of lead wire	H <sub>0</sub>	16.0 ± 0.5	
Feed hole diameter	D <sub>0</sub>	4.0 ± 0.2	
Tape thickness	t	0.7 ± 0.2	
Defective product (2)	ΔC	0 ± 1.0	



Powerex, Inc., Hillis Street, Youngwood, Pennsylvania 15697 (412) 925-7272  
 Powerex Europe, S.A., 428 Avenue G. Durand, BP107, 72003 Le Mans, France (43) 41.14.14

Powerex Semiconductor Data Book  
 Taping

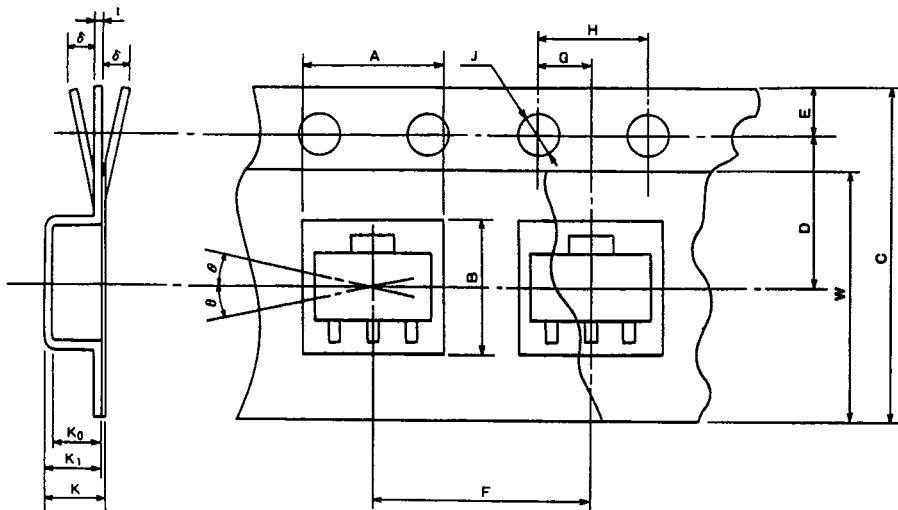

SOT-89 Package

Thyristor  
 CR08AS

Taping dimensions

Description of symbol		Symbol	Dimensions/angles Unit:mm	Remark
Parts insertion	Height	A	$5.0 \pm 0.1$	Cross-section of the surface 0.5mm above the inner bottom
	Width	B	$4.6 \pm 0.1$	Cross-section of the surface 0.5mm above the inner bottom
Concave square hole	Depth	K <sub>0</sub>	$1.8 \pm 0.1$	Inner space
	Pitch	F	$8.0 \pm 0.1$	Cumulative error +0.1/-0.3 MAX/10 pitches
Round feed hole	Diameter	J	$\phi 1.5 \pm 0.05$	
	Pitch	H	$4.0 \pm 0.1$	Cumulative error +0.1/-0.3 MAX/10 pitches
	Position	E	$1.5 \pm 0.1$	Distance between the tape edge and the hole center
Distance between center lines	Vertical	G	$2.0 \pm 0.5$	Center line of concave square hole and round feed hole
	Horizontal	D	$5.65 \pm 0.05$	Center line of concave square hole and round feed hole
Cover tape	Width	W	$9.5 + 0.3/-0$	Thickness: 0.1 MAX
Carrier tape	Width	C	$12 \pm 0.2$	Warp $\pm 0.3$ MAX
	Thickness	t	$0.3 \pm 0.05$	
	Package hole depth	K <sub>1</sub>	$2.1 \pm 0.1$	
Device	Package dimensions	—	—	As shown in (e)
	Inclination	$\theta$	30° MAX.	
Total Thickness		K	$2.3 \pm 0.1$	Total thickness including cover and carrier tapes