

NOTES:

1. MATERIALS OF CONSTRUCTION:
 BODY = BRASS, NICKEL PLATED (.000100 MIN THICK)
 CONTACT PIN = BeCu, GOLD PLATED (.000030 MIN THICK)
 INSULATOR = TEFLON, MIL-P-19468

31-70249		REVISIONS			
DRAWING NO.	REV	DESCRIPTION	DATE	ECO	APPR
THIRD ANGLE PROJ.	A	RELEASE TO MFG.	8/22/01	43838	CPM

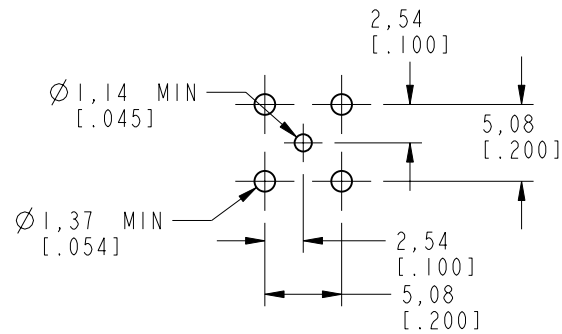
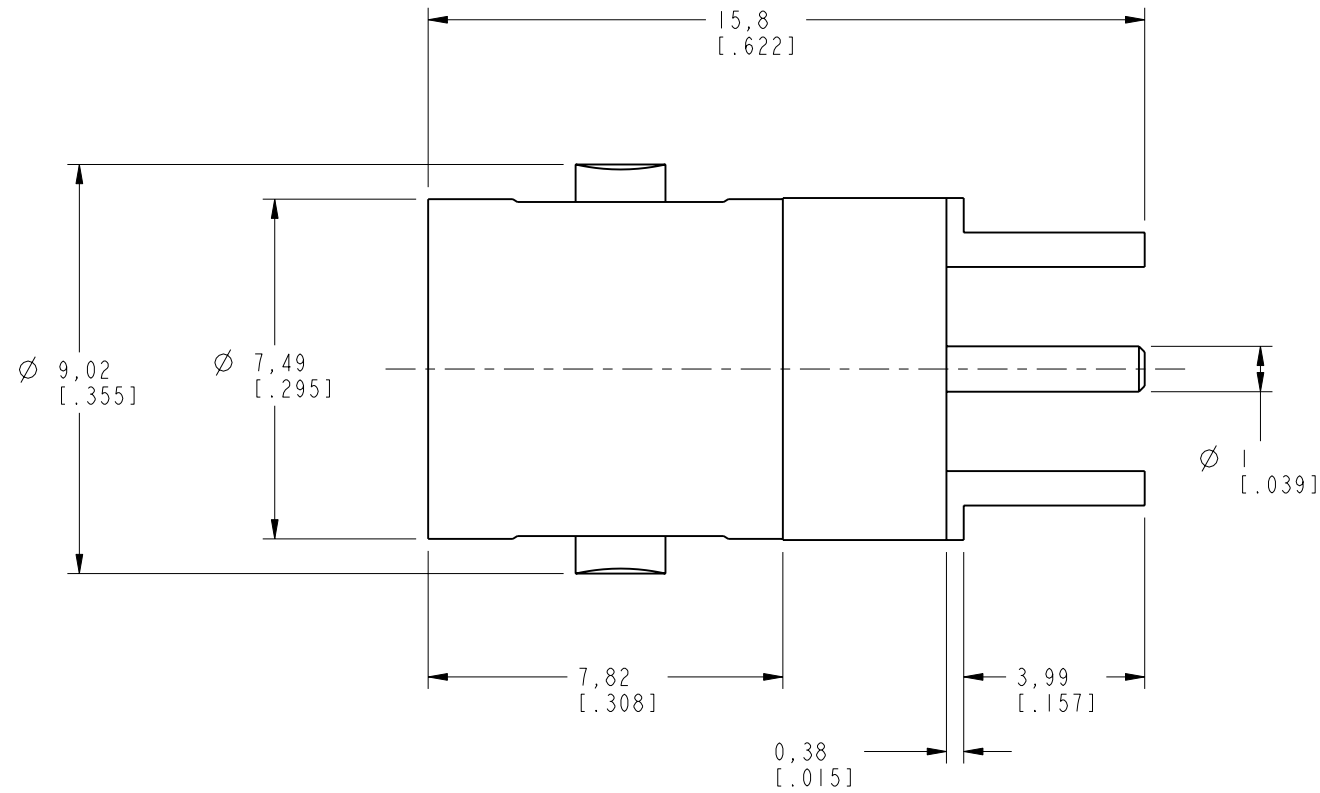

RECOMMENDED PCB
 MOUNTING HOLE DIMENSIONS
 SCALE 2.000

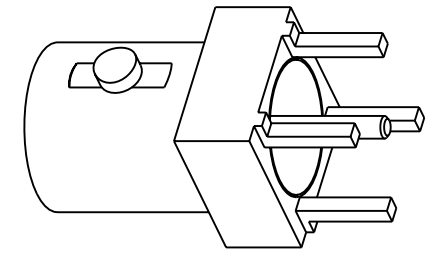

SCALE 3.000

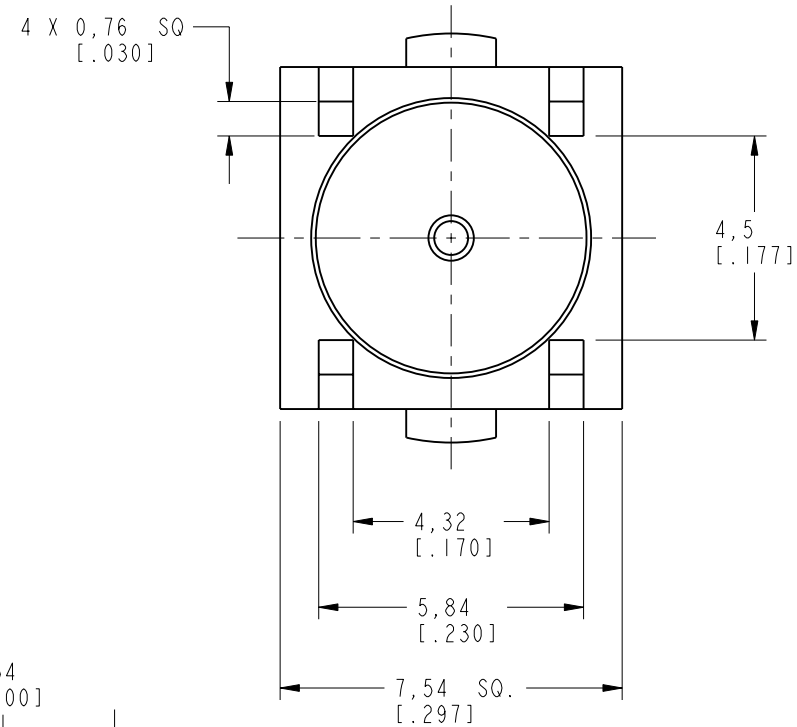

CUSTOMER OUTLINE DRAWING

ALL OTHER SHEETS ARE FOR INTERNAL USE ONLY

UNLESS OTHERWISE SPECIFIED, DIMENSIONS ARE IN INCHES AND TOLERANCES ARE: 0.5 - 6mm ±0.2mm 6 - 30mm ±0.4mm 30 - 120mm ±0.6mm	MATERIAL	DRAWN C. McGRATH	DATE 16-Aug-01	TITLE MINI BNC P.C. MOUNT RECEPT. JACK	Amphenol Amphenol Corporation Communication and Network Products Division Danbury, CT U.S.A. 06810	
	REFERENCE EAR 364 GEN# 31-6057_ASSY	ENGINEER O. BARTHELMS	DATE 16-Aug-01	APPROVED O. BARTHELMS		DATE 22-Aug-01
NOTICE - These drawings, specifications, or other data (1) are, and remain the property of Amphenol Corp. (2) must be returned upon request; and (3) are confidential and not to be disclosed to any person other than those to whom they are given by Amphenol Corp. The furnishing of these drawings, specifications, or other data by Amphenol Corp., or to any other person to anyone for any purpose is not to be regarded by implication or otherwise in any manner licensing, granting rights or permitting such holder or any other person to manufacture, use or sell any product, process or design, patented or otherwise, that may in any way be related to or disclosed by said drawings, specifications, or other data.		CAD FILE I:\BNC\31-70249	CODE ID 74868	DWG SIZE B	DRAWING NO. 31-70249	REV A
				SCALE: 6.0:1	SHEET 2 OF 2	