

Applications

- Temperature measurement and compensation for mobile phone applications (e.g. battery pack, TCXO, LCD display), automotive and data systems

Features

- Multilayer SMD NTC with inner electrodes
- Standard EIA chip size 0805
- Ni - Barrier termination (Ag/Ni/Sn)
- High accuracy: $\pm 5\%$ in resistance, $\pm 3\%$ in B-value
- Excellent long term ageing stability in high temperature and high humidity environment
- Superior resistance stability during soldering, therefore almost no change ($< 1\%$) during soldering
- The component is compliant with ROHS (DIRECTIVE 2002/95/EC OF THE EUROPEAN PARLIAMENT AND THE COUNCIL of 27 January 2003 on the restriction of the use of certain hazardous substances in electrical and electronic equipment)

Part Dimensions

Type	L	W	T	k
0805	2.0 ± 0.20	1.25 ± 0.15	1.30 max.	0.50 ± 0.25

Dimensions in mm

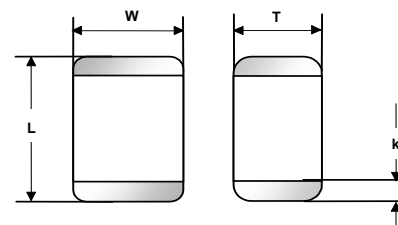
 Termination Ag/Ni/Sn Dimensions in [mm]

Electrical Specifications

Part Number	Zero-Power Resistance (at 25°C)	B _{25/100}	B _{25/85}	B _{25/50}
B57431V2472J062	100kΩ \pm 5%	4500 K \pm 3%	(4470 K)	(4390 K)

Climatic Category (IEC 60068-1)	55/125/56
Lower category temperature	-55°C
Higher category temperature	125°C
Power rating at 25°C	P ₂₅ 210mW¹⁾
Dissipation factor (on PCB)	G _{th} approx. 3.5 mW/K¹⁾
Thermal cooling time constant (on PCB)	T _{th} approx. 10.0 s¹⁾
Heat capacity	C _{th} approx. 35 mJ/K¹⁾
Weight of component	approx. 13 mg

¹⁾ Depends on mounting situation

ISSUE DATE	08.12.2005	ISSUE	a	PUBLISHER	KB S PE	PAGE	1/7
------------	------------	-------	---	-----------	---------	------	-----



SMD NTC Thermistor

SMD NTC Thermistor with Ni-Barrier Termination

B57431V2104J062

Data sheet

Resistance - Temperature Characteristic

NTC Resistance Temperature Curve

R/T-Curve 8503 / A01
 R at 25°C 100000 [Ohm]
 B(25/100) 4500[K] ± 3 [%]
 Rn at 25°C 100000 [Ohm] ± 5 [%]

T [°C]	R_Nom [Ω]	R_Min [Ω]	R_Max [Ω]	ΔR/R25 [±%]	ΔT [±°C]
-55	13251642	10382025	16121259	21,7	2,8
-50	9052292	7217556	10887029	20,3	2,7
-45	6263714	5077217	7450210	18,9	2,6
-40	4386660	3611387	5161932	17,7	2,5
-35	3107081	2595726	3618436	16,5	2,4
-30	2224393	1884237	2564548	15,3	2,3
-25	1608658	1380657	1836659	14,2	2,2
-20	1174593	1020735	1328451	13,1	2,1
-15	865527	761093	969962	12,1	2,0
-10	643370	572134	714606	11,1	1,9
-5	482234	433452	531015	10,1	1,8
0	364348	330849	397847	9,2	1,7
5	277391	254352	300430	8,3	1,5
10	212741	196894	228587	7,4	1,4
15	164311	153431	175190	6,6	1,3
20	127767	120328	135206	5,8	1,2
25	100000	95000	105000	5,0	1,0
30	78759	74194	83325	5,8	1,2
35	62406	58338	66475	6,5	1,4
40	49737	46147	53328	7,2	1,6
45	39863	36716	43011	7,9	1,8
50	32123	29376	34871	8,6	2,0
55	26022	23631	28413	9,2	2,2
60	21186	19109	23264	9,8	2,4
65	17334	15530	19137	10,4	2,6
70	14249	12683	15814	11,0	2,8
75	11767	10407	13126	11,6	3,1
80	9760	8579	10941	12,1	3,3
85	8130	7103	9157	12,6	3,5
90	6800	5906	7695	13,2	3,7
95	5711	4931	6491	13,7	4,0
100	4815	4134	5496	14,2	4,2
105	4075	3479	4671	14,6	4,4
110	3461	2938	3983	15,1	4,7
115	2950	2491	3409	15,5	4,9
120	2523	2120	2927	16,0	5,2
125	2165	1810	2521	16,4	5,4

ISSUE DATE	08.12.2005	ISSUE	a	PUBLISHER	KB S PE	PAGE	2/7
------------	------------	-------	---	-----------	---------	------	-----

Reliability

Tests of SMD NTC thermistors are made according to IEC 60068. The parts are mounted on standardized PCB in accordance with IEC 60539-1.

Test	Standard	Test conditions	$\Delta R_{25} / R_{25}$ (typical)	Remarks
Storage in dry heat	IEC 60068-2-2 (=JIS C 0021)	Storage at upper category temperature T: 125°C t: 1000h	< 2%	
Storage in damp heat, steady state	IEC 60068-2-3 (=JIS C 0022)	Temperature of air: 40°C relative humidity of air: 93% Duration: 56days	< 2%	No visible damage
Rapid temperature cycling	IEC 60068-2-14 (=JIS C 0025)	Lower test temperature: -55°C Upper test temperature: 125°C Number of cycles: 100	< 2%	
Endurance at P _{max}	-	P _{max} =210mW Duration: 1000h	< 2%	
Solderability	IEC 60068-2-58 (=JIS C 0054)	Solderability: 215°C/3s 235°C/2s Resistance to soldering heat: 260°C/10s		95% of termination wetted
Resistance drift after soldering	-	reflow soldering profile wave soldering profile	< 1%	

Mounting Instructions

1. Termination Ni-barrier termination (Ag/Ni/Sn)

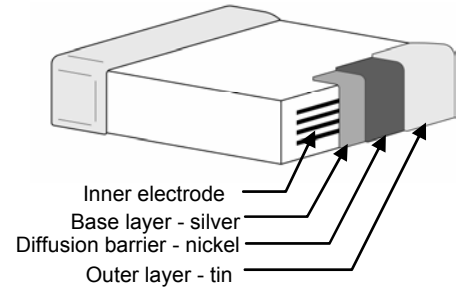

2. Recommended geometry of solder pads

Size	A [mm]	B [mm]	C [mm]	D [mm]
0805	1.3	1.2	1.0	3.4

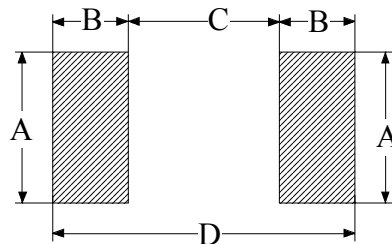

3. Requirements for Solderability

- Wettability test in accordance with IEC 60068-2-58 (= JIS C 0054) :

Preconditioning: Immersion into flux F-SW 32.

Evaluation criteria: Wetting of soldering areas $\geq 95\%$.

Pb-containing solder: *Sn(60)Pb(40)*

Bath temperature (°C): 215 ± 3

Dwell time (s): 3 ± 0.3

Pb-free solder: *Sn(95.1-96.0)Ag(3.0-4.0)Cu(0.5-0.9)*

Bath temperature (°C): 245 ± 5

Dwell time (s): 3 ± 0.3

- Soldering heat resistance test in accordance with IEC 60068-2-58 (= JIS C 0054) :

Preconditioning: Immersion into flux F-SW 32.

Evaluation criteria: Leaching of side edges $\leq 1/3$.

Solder: *Sn(60)Pb(40)*, *Sn(95.1-96.0)Ag(3.0-4.0)Cu(0.5-0.9)*

Bath temperature (°C): 260 ± 5

Dwell time (s): 10 ± 1

ISSUE DATE	08.12.2005	ISSUE	a	PUBLISHER	KB S PE	PAGE	4/7
------------	------------	-------	---	-----------	---------	------	-----

4. Recommended soldering profiles

Reflow soldering profile: (according to CECC 00802)

Temperature characteristics at component terminals during reflow soldering (two cycles are permitted).

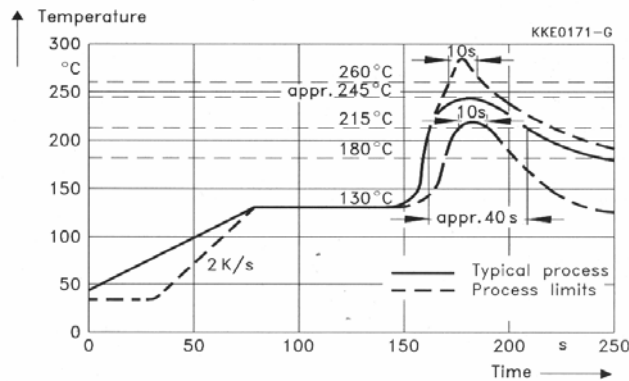

Wave soldering profile:

Temperature characteristics at component terminals during wave soldering can be recommended once in general.

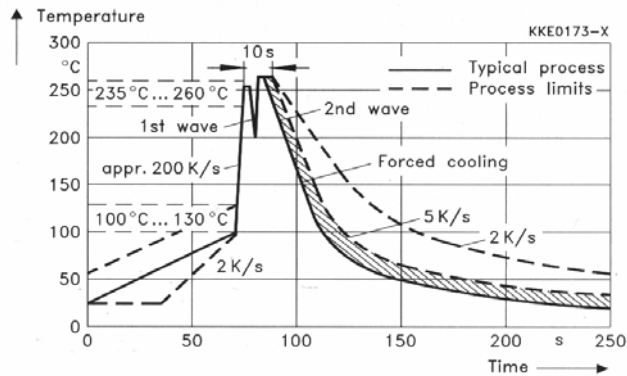

5. Storage conditions

Solderability is guaranteed for 12 months from date of delivery for types with Ni-barrier termination, provided that the components are stored in the original packages.

Storage temperature: -25 ... +45°C

Relative humidity: < 75% annual average, < 95% on max. 30 days in a year, dew precipitation and wetness are inadmissible.

Taping and Packing

Taping:

Tape and reel packing comply with specifications of IEC 60286-3

Blister tape

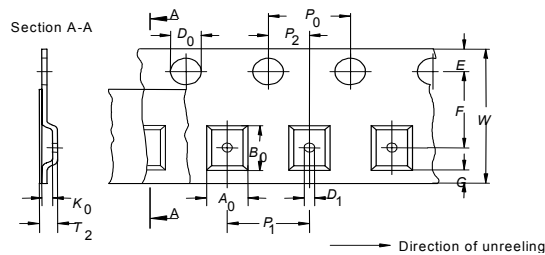

Dimensions and tolerances:

Definition	Symbol	Dimension (mm)	Tol. (mm)
		Size 0805	
Compartment width x Compartments length	$A_0 \times B_0$	1.6 x 2.4	± 0.2
Compartment height	K_0	1.4	max.
Overall thickness	T_2	2.5	max.
	T	0.3	max.
Sprocket hole diameter	D_0	1.5	+0.1/-0
Compartment hole diameter	D_1	1.0	min.
Sprocket hole pitch	P_0	4.0	$\pm 0.1^{1)}$
Distance centre hole to centre compartment	P_2	2.0	± 0.05
Pitch of the component compartments	P_1	4.0	± 0.1
Tape width	W	8.0	± 0.3
Distance edge to centre of hole	E	1.75	± 0.1
Distance centre hole to centre compartment	F	3.5	± 0.05
Distance edge to centre compartment	G	0.75	min.

¹⁾ ≤ 0.2 mm over 10 sprocket holes.

Part orientation in tape pocket

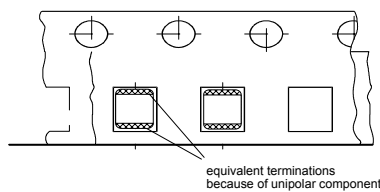

Reel Packing:
Reel material: PS.

Tape material: Blister

Tape break force: min. 10N

Top cover tape peel force: 0.1 - 0.65N at a peel speed of 300 mm/min, angle between top cover tape and the direction of feed during peel off: 165 -180°.

Top cover tape strength: min. 10N

Length of tape:
Leader section: additional top cover tape, length min 400 mm, before component section (including carrier tape with empty cavities, length min. 150 mm or min. 20 pcs. of empty cavities).

Trailer section: length min. 40 mm.

Empty part cavities at leader and trailer section on tape are sealed with top cover tape.

Cavity play:

Each part rests in the cavity so that the angle between the part centreline and the cavity centreline is no more than 20°.

Weight of loaded reel: max. 1500 g

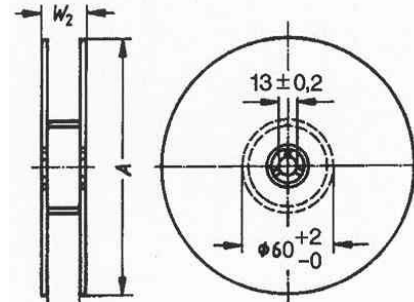
Packing units: 3000pcs.

Package 8 mm tape

Definition	Symbol	Dim. (mm)	Tol. (mm)
Reel diameter	A	180	-3/+0
Reel width (inside)	W ₁	8.4	+1.5/-0
Reel width (outside)	W ₂	14.4	max.

© EPCOS AG 2005. Reproduction, publication and dissemination of this data sheet, enclosures hereto and the information contained therein without EPCOS' prior express consent is prohibited.

Purchase orders are subject to the General Conditions for the Supply of Products and Services of the Electrical and Electronics Industry recommended by the ZVEI (German Electrical and Electronic Manufacturers' Association), unless otherwise agreed.

ISSUE DATE	08.12.2005	ISSUE	a	PUBLISHER	KB S PE	PAGE	7/7
------------	------------	-------	---	-----------	---------	------	-----