

# euro-block

product specification

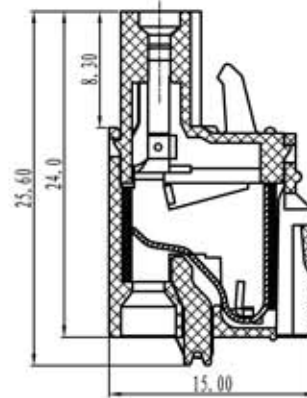
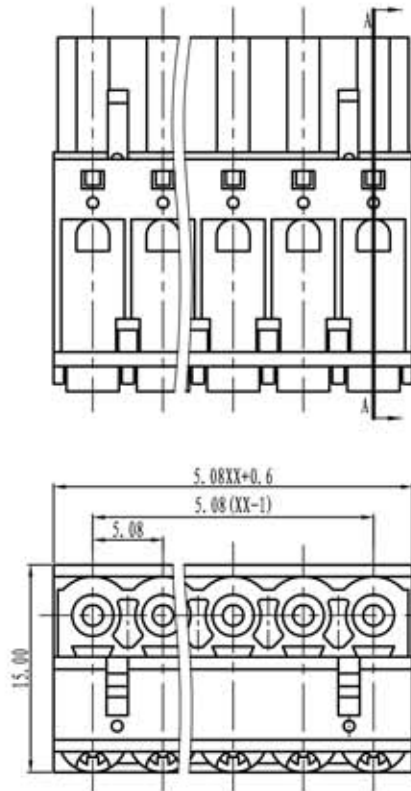

SECTION A-A

## Electrical

Standard: UL-IEC  
 Rated voltage: 300V-320V  
 Rated current: 12A-15A  
 Contact resistance: 20m  $\Omega$   
 Insulation resistance: 500M  $\Omega$ /DC500V  
 Withstanding voltage: AC2000V/1Min  
 Wire range: 28-14AWG 2.5mm<sup>2</sup>

## Mechanical

Temp.Range: -40°C~+105°C  
 Strip length: 7-8mm

## Dimensions

Pitch: 5.08mm  
 Poles: 2p-24p

## Material

Housing: PA66, UL94V-0  
 Clamp 1: Stainless steel  
 Clamp 2: Phosphor bronze, Ni plated

Schema generale del codice di ordinazione / General description of ordering code

serie	n°poli	passo	versione	colore	custom
CFS	02÷24	5.08			

TOLERANCES EXCEPT AS NOTED

	linear dimension					fillet	chamfer	short angle sid				≡	-	□	//	⊥	
	to	over	over	over	over			to	to	to	to						to
variable range	to 6	to 30	to 120	to 480	to 480	all	to 6	to 10	to 50	to 120	to 120	all	to 5	to 30	to 120	to 120	
tolerance	±0.1	±0.2	±0.3	±0.5	±0.9	±0.2	±0.5	±1	1'	30'	20'	10'	0.5	0.025	0.06	0.12	0.4

UNITS	mm	SIZE	A4	SCALE		FIRST ANGLE PROJECTION	
<b>euro-block</b>							
						NAME	CFS-5.08