

Customer Information Sheet

DRAWING No.: M80-843XXXX

SHEET 2 OF 2

IF IN DOUBT - ASK

(C)

NOT TO SCALE

THIRD ANGLE PROJECTION

ALL DIMENSIONS IN mm

ORDER CODE:

M80-843XXXX

TOTAL No. OF WAYS

02-07, 17, 22

FINISH

45 - GOLD

42 - SELECTIVE GOLD /100% TIN

NOTES:

- 2-OFF STRAIN RELIEF STRAP M80-0030006 ARE INCLUDED WITH EACH CONNECTOR.

SPECIFICATIONS:

MATERIAL:

MOULDING = GLASS-FILLED POLYAMIDE 46 UL94V-0, BLACK

CONTACTS = PHOSPHOR BRONZE

FINISH:

CONTACTS:

45 = 0.75µ GOLD

42 = 0.75µ GOLD ON CONTACT AREA, 3.0µ 100% TIN ON TAILS

ELECTRICAL:

CURRENT RATING AT 25°C = 3.0A MAX

CURRENT RATING AT 85°C = 2.2A MAX

WORKING VOLTAGE = 120V AC/DC

VOLTAGE PROOF = 360V AC/DC

CONTACT RESISTANCE (INITIAL) = 20 mΩ MAX

CONTACT RESISTANCE (AFTER CONDITIONING) = 25 mΩ MAX

INSULATION RESISTANCE (INITIAL) = 1,000 MΩ MIN

INSULATION RESISTANCE (AFTER CONDITIONING) = 100 MΩ MIN

MECHANICAL:

DURABILITY = 500 OPERATIONS

ENVIRONMENTAL:

TEMPERATURE RANGE = -55°C TO +125°C

PACKING:

TUBE

FOR COMPLETE SPECIFICATION, SEE COMPONENT SPECIFICATION C005XX (LATEST ISSUE)

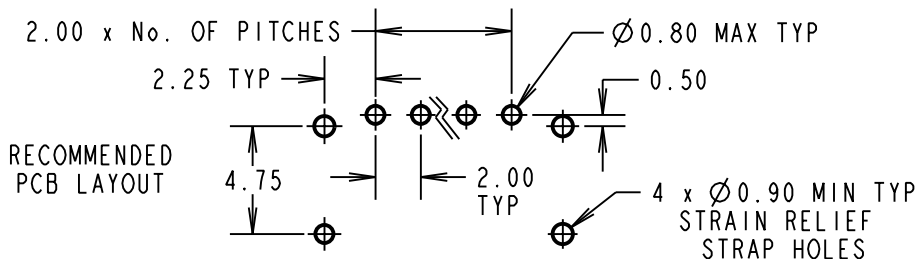
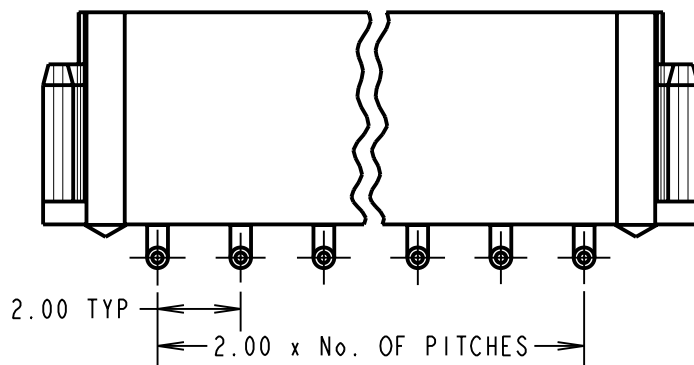
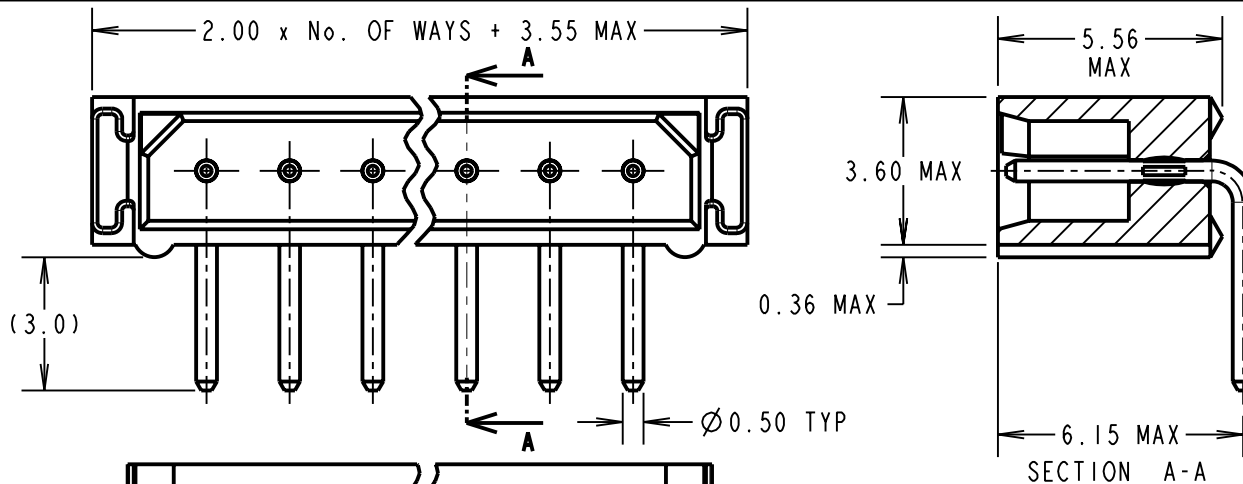

CP	5	30.09.09	10303
NAME	ISS.	DATE	C/NOTE
APPROVED: C.PENROSE			
CHECKED: R.ADDE			
DRAWN: I. SANDY			
CUSTOMER REF.:			
ASSEMBLY DRG:			

HARWIN

HARWIN USA
TEL: 603 893 5376
FAX: 603 893 5396
mis@harwin.com

HARWIN Europe (UK)
TEL: 023 9231 4545
FAX: 023 9231 4590
mis@harwin.co.uk

HARWIN Asia
TEL: +65 6 779 4909
FAX: +65 6 779 3868
mis@harwin.com.sg

THIS DRAWING AND ANY INFORMATION OR DESCRIPTIVE MATTER SET OUT HEREON ARE CONFIDENTIAL AND COPYRIGHT PROPERTY OF THE HARWIN GROUP AND MUST NOT BE DISCLOSED, LOANED, COPIED OR USED FOR MANUFACTURING, TENDERING OR FOR ANY OTHER PURPOSE WITHOUT THEIR WRITTEN PERMISSION.

TOLERANCES

X. = ±1mm
X.X = ±0.25mm
X.XX = ±0.10mm
X.XXX = ±0.01mm

ANGLES = ±5°
UNLESS STATED

MATERIAL:

SEE ABOVE

FINISH:

S/AREA:

mm²

TITLE: DATAMATE 2mm PITCH
HORIZONTAL PC TAIL SIL PLUG
ASSEMBLY - UNLATCHED (RoHS)

DRAWING NUMBER:

M80-843XXXX

SHT
2
OF 2